

My Weigh MD Series

INSTRUCTION MANUAL

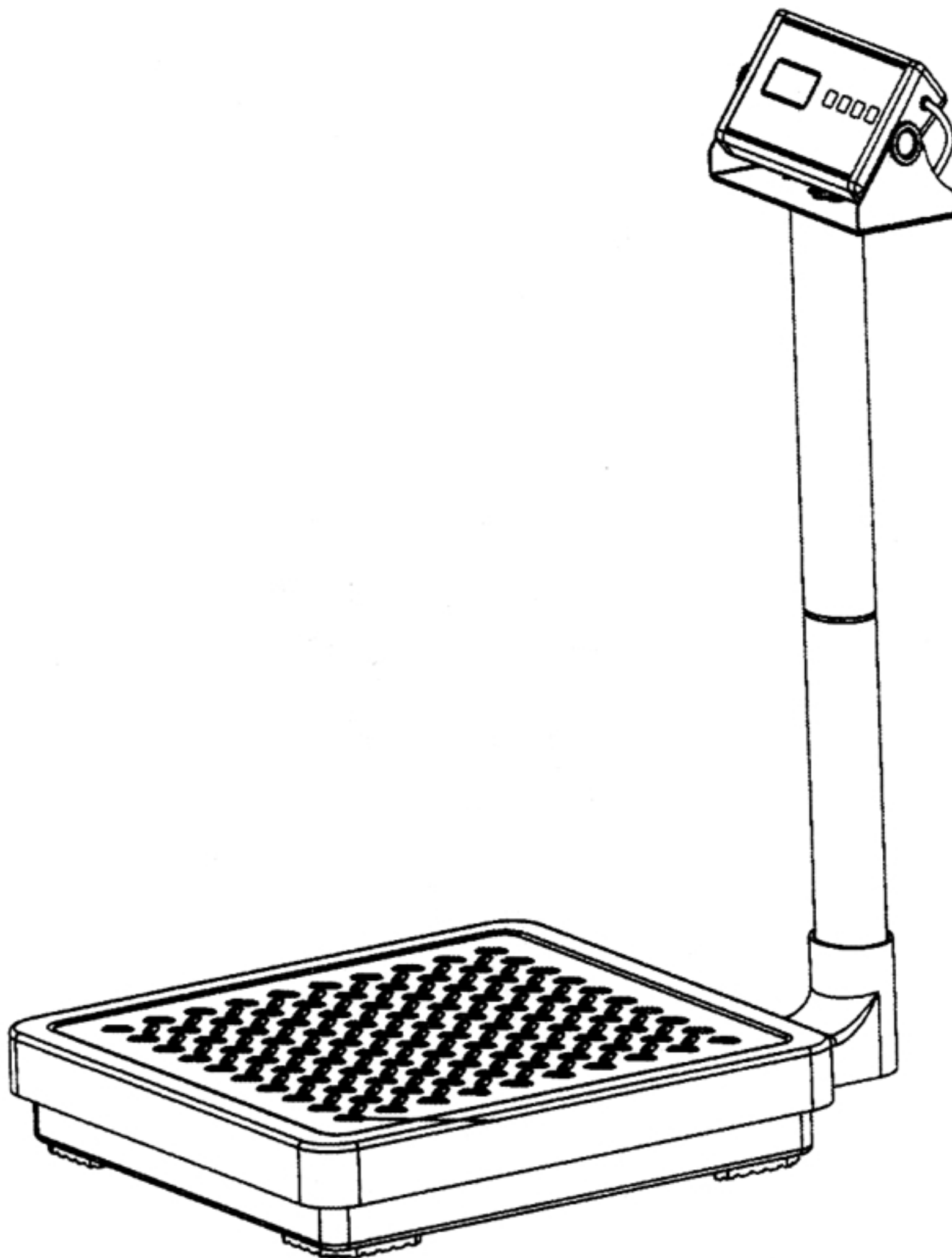

(Installation diagram)

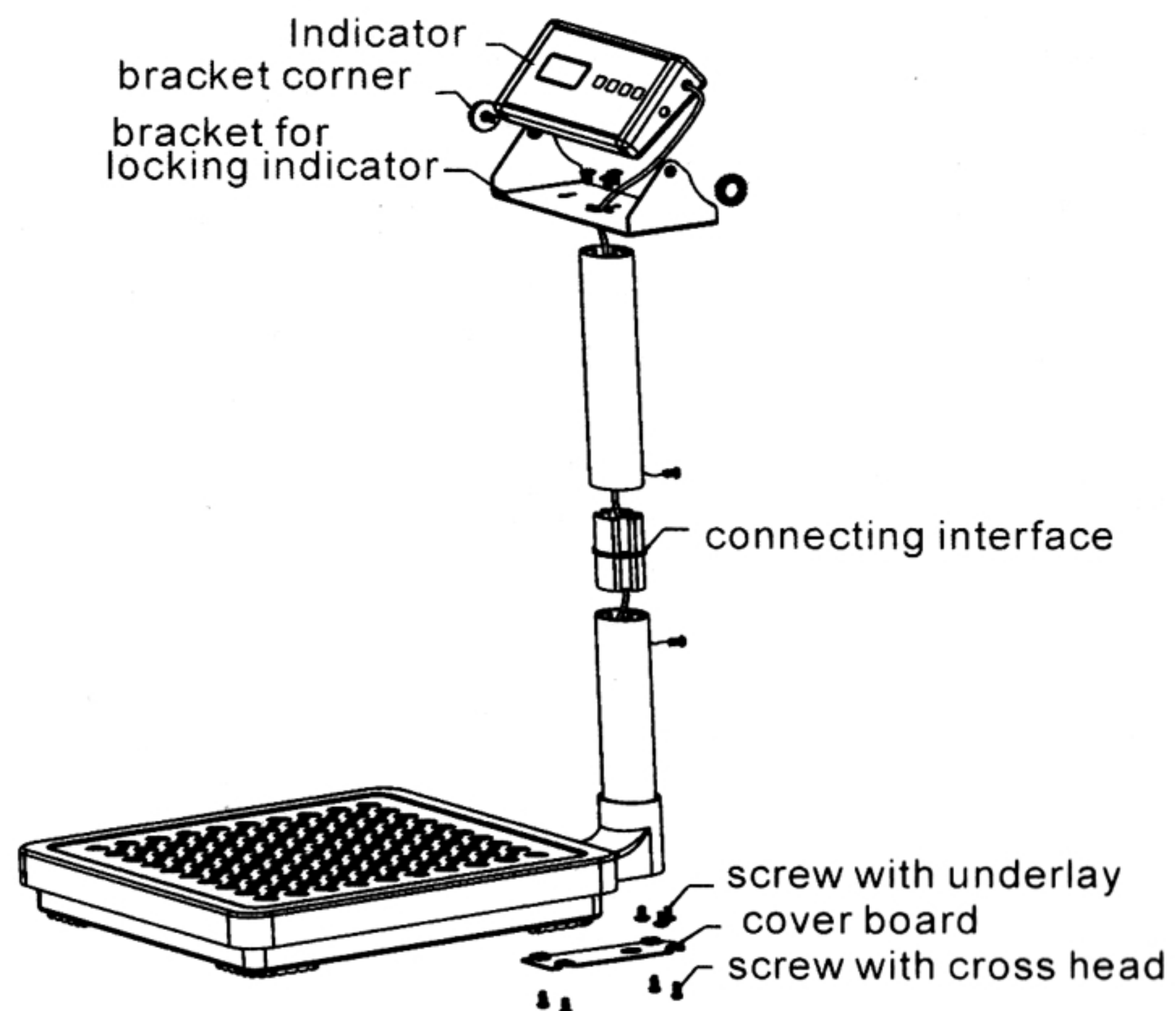
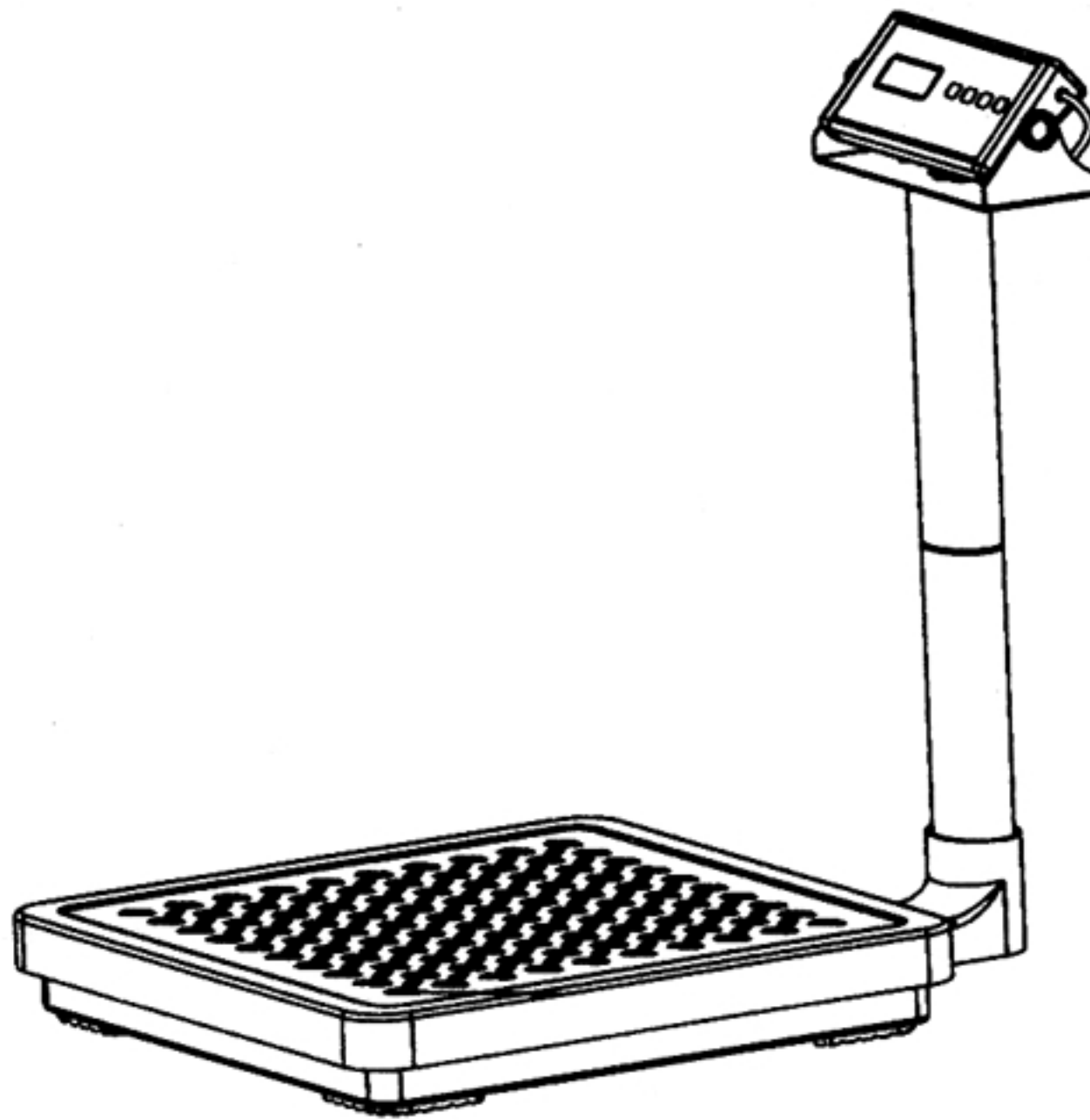

SAFETY PRECAUTIONS

All safety messages are identified by the words "**WARNING**" and "**CAUTION**". These words mean the following:

△WARNING	Important information to alert you to a situation that might cause serious injury and damage to your property if instructions are not followed.
△CAUTION	Important information that tells how to prevent damage to the equipment.

When using the scale, the following safety precautions should always be followed.

△ WARNING

Use only the correct AC adaptor with the scale. Other adaptors may cause permanent electrical damage.

△ CAUTION

Avoid placing the scale in direct sunlight, this may cause discoloration or malfunction.

Replace all batteries at the same time – Do not replace only a portion of the 6 batteries as this may cause a malfunction.

If the scale is not to be used for a long period of time, remove all batteries from the battery compartment to avoid leakage, which may cause damage to this scale.

Avoid overloading the scale, as this may cause permanent damage and void your warranty – do not EVER exceed the maximum capacity of the scale

Keep the scale away from water – this scale is not water resistant. Shock, injury and electrical damage can occur if used in a wet location!

Matter charged with static electricity could affect accuracy. Discharge all static electricity. For example, one method is to use Static-Guard spray, and spray it on both sides of the weighing platform.

PARTS DESCRIPTION

► SIDE

AC adaptor
Socket

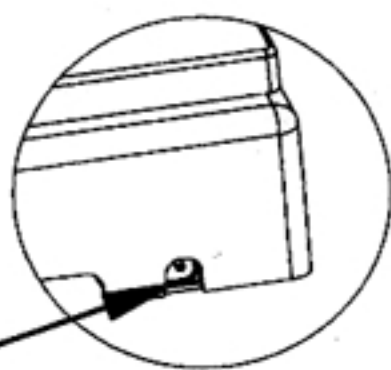

ON/OFF key
Turns the scale
power on/off.

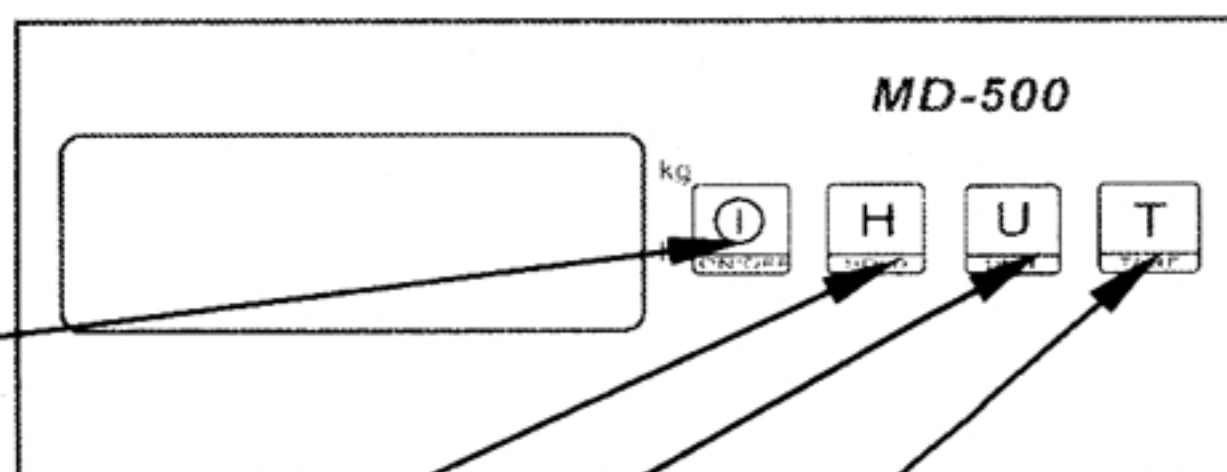

HOLD KEY
Remain on the display for 120 seconds.

UNIT key
Changes weighing units, eg. kg or lb.,

TARE key (for ZERO)
Subtracts weight of a container or
Sets display to zero.

► DISPLAY

Negative value indicator

Low battery indicator

Weighing unit

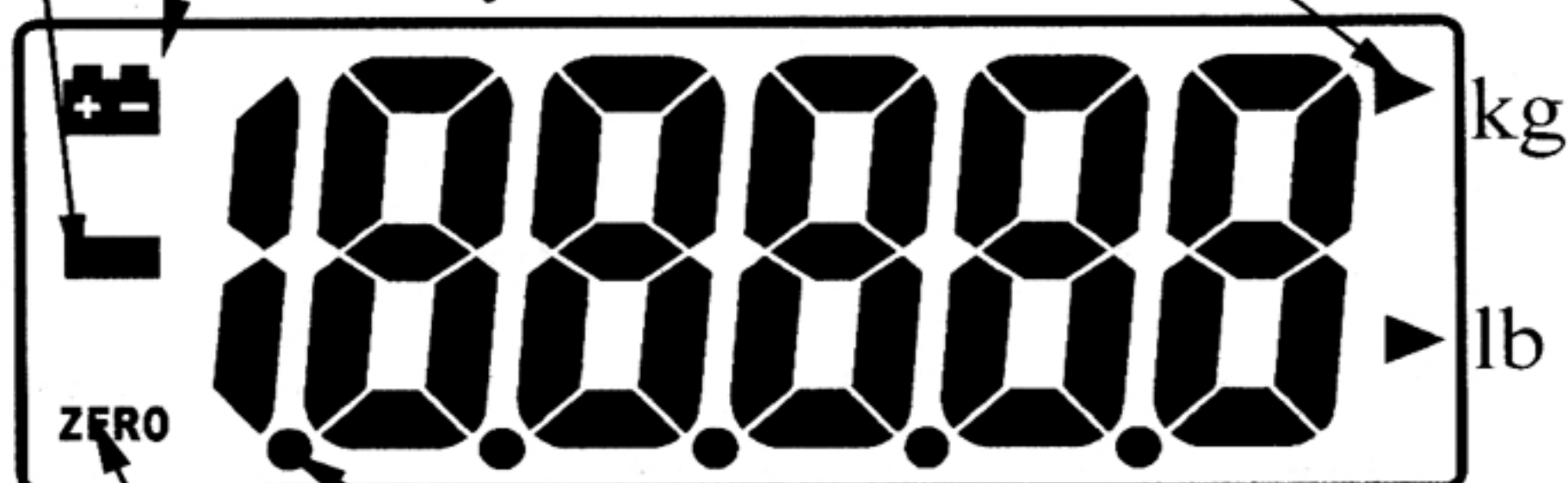

ZERO

Hold indicator

ZERO indicator

Indicates when the reading is "0".

HOLD(send data) FUNCTION

Once the hold key is pressed: 1). The CPU will send weight data into RS232 socket. 2)the weight will remain on the display for 120 seconds after the item has been removed from the scale so the weight can easily be read.

- 1) Place the item on the scale platform.
- 2) Wait for the stable weights to be displayed.
- 3) Press the **hold** key. The “.” hold indicator will turn-on.
- 4) Remove the item from the scale platform. The item’s weight reading will remain on the display for 120 seconds.
- 5) Quit to hold function: Once an item is weighed and the **hold** function is enabled; you want to quit to hold function, Press the **hold** key again to cancel the “.” hold indicator and return the scale to weight value.

FUNCTION SETTINGS

1. Enter function setting mode.

Press [ON/OFF] to turn the power off, Press [HOLD] first, then press [ON/OFF], while keeping [HOLD] pressed, the display will show **A_ON** or **A_OFF**.

2. Selection of auto shut off mode.

When the balance enter function setting menu. Press [HOLD] key, the display will show **A_ON** or **A_OFF**, Press [TARE] key, selection display **A_ON**, this means auto shut off function active. Press [TARE] again, the display will show **A_OFF**, this means auto shut off function inactive.

3. Selection of auto backlight mode.

When the balance enter function setting menu. Press [HOLD] key, the display will show **L_ON** or **L_OFF**, press [TARE], selection display **L_ON**, this means auto backlight function active, press [TARE] again, the display will show **L_OFF**, this means auto backlight function inactive, i.e. shut off backlight function.

WEIGHING

Before weighing

Whenever possible, please allow the scale to warm up for several seconds after first turning the power on so that the scale will function properly and accurately.

Error messages

EEEE: Overload

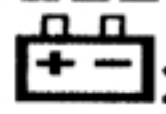
: Low battery

Weighing procedures

1. Press [ON/OFF] to turn on the scale.

When the power is turned on, the display show the digit "8" continuously cycle and finally "0" will appear on the display .

2. Select the weighing unit with [UNIT].

Press [UNIT] to select a weighing unit "kg", "lb".

Once the unit has been selected, the selected unit will be displayed next to the weight value.

3. Start weighing

If you do not use a container for weighing,

Verify the reading is "0". If not, press [TARE] to display "0".

Place the items to be weighed on the platform.

The weighing is displayed.

If you use a container for weighing,

Place an empty container on the platform.

Wait for 3 seconds and press [TARE].

Place the objects to be weighed in the container.

The weighing is displayed.

CALIBRATION

When to calibrate - calibration is almost never required.

If the scale is inaccurate, calibration may be desired when the scale is first set up for use, or if the scale is moved to a different altitude or gravitation. This is necessary because the weight of a mass in one location is not necessarily the same in another location. Also, with time and use, mechanical deviations can occur.

How to calibrate

****you must have an accurate the full load kilogram weight or combination of weights in order to calibrate****

- 1. The scale must be powered OFF.** Press and hold [TARE] first, then Press [ON/OFF] while keeping the [TARE] button depressed, then release both keys. The display will show 88888 and then the A/D value (a series of random numbers).
2. Wait for the stable indicator to be displayed, Press [UNIT] the display will show "SAVE0", then the display will 200.0.
- 3. Place 200kg weight(s) on platform.** Wait for the stable indicator to be displayed, , then press [UNIT], the display will show "SAVE1" then AD value. Calibration is complete, remove the weight(s).
- 4. Turn the scale OFF** (Press the ON/OFF key) , then turn it back ON and check some weight readings. If calibration is still incorrect, repeat calibration but try it more slowly.

If calibration is repeatedly incorrect then: 1) Replace the batteries, 2) Try a more stable surface or vibration and interference free location.

FEATURES

- Auto shut off (optional)
- Auto zero tracking
- Removable display w/3ft cord
- Large LCD (5 digits 28 mm high)
- Large square weighing tray.
- Auto calibration
- AC Power (optional)
- kg /lb conversion
- Hold function
- Auto backlight(optional)

SPECIFICATIONS

Model number	Capacity	Division
MD-500	500lb	0.2lb
Platter / Tray	14 × 14 inch	
Net/gross weight	6.1kg/7.6kg	
Package	Standard carton: 65.5 × 56 × 13(cm ³)	
	2 Units in one box: 67.5 × 58 × 28(cm ³)	
Operating Temperature	Optimum: 15-30°C (62-90f)	
Power source	6 × AA Batteries or AC/DC	
	Adapter 9V/100mA (optional)	

SPECIAL WARNING

Cell-Phones, Cordless-Phones, and any radio-frequency device can cause temporary interference and cause the scale to temporarily not work properly. Please do not use any electronic device near the shipping scale. Just like in an Airplane, do not use your cell-phone near the scale when it is in use. While there is NO risk of permanent damage to the scale, interference can cause an incorrect calibration or incorrect weight readings.

The use method of computer RS232 socket: refer to photo Disk.

ASC II code receive parameter (the RS232 transfer parameter)

Baud rate 9600

Parity bit none

Data bit 8

Stop bit 1