

ECOVACS

Robot Air Purifier

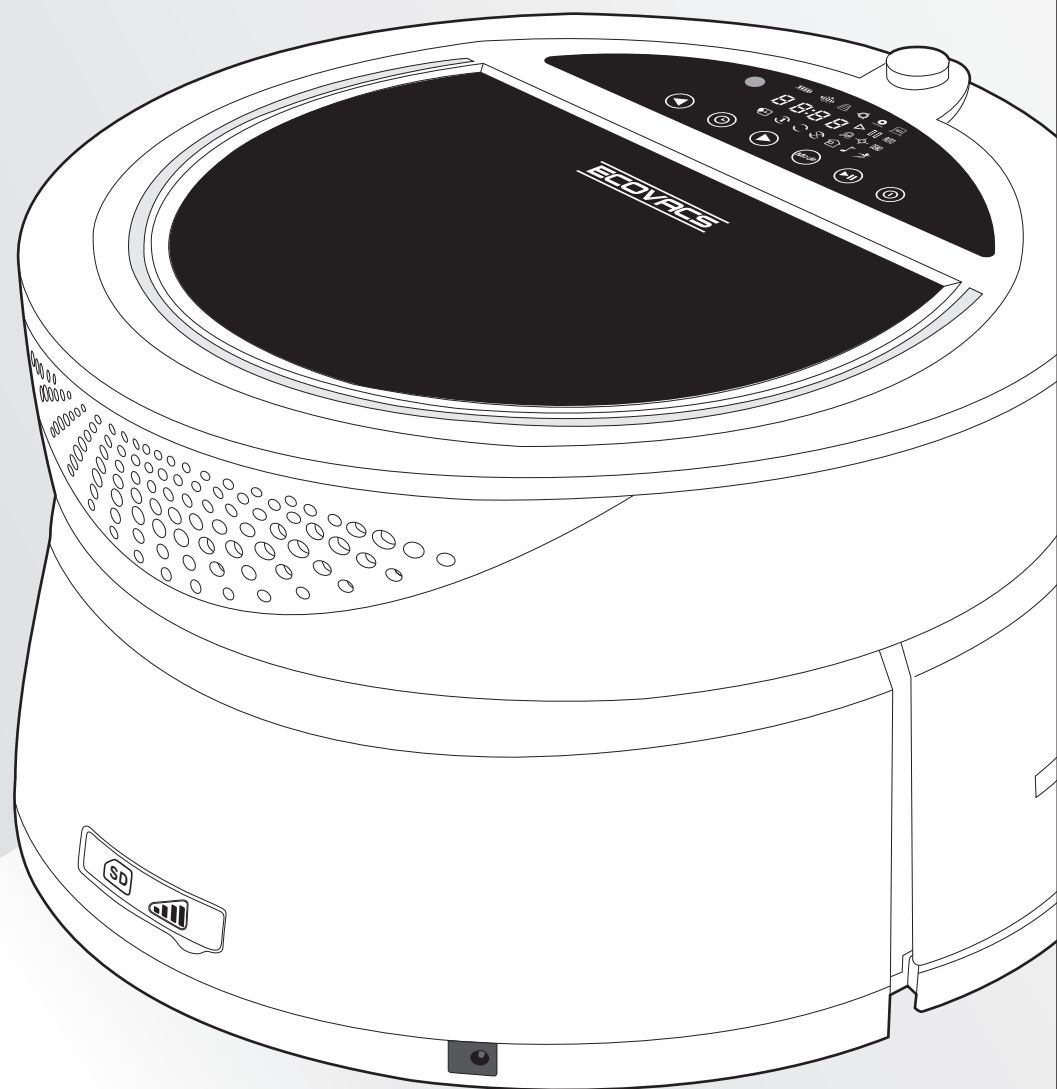

A320/A330
USER GUIDE

Welcome and congratulations on your purchase of a Robot Air Purifier.

We trust the purchase of your new product will help you to keep your home clean and provide you more quality time to do other things.

Before you go any further, we ask you to record your model number, serial number and date of purchase below. We also suggest you attach your Receipt to this page for safe keeping.

(Model and Serial numbers are located on the label on the bottom of the Robot.)

MODEL # _____

SERIAL # _____

DATE OF PURCHASE ___ / ___ / ___

Should you have any problems in programming or getting your product to function properly, we ask you to call us first before contacting or returning the product to the place where you purchased it.

Call 1-8 __ - _____ for assistance.

(Provide 1-8 __ - _____ phone number also provide address of US business Office and WEB site for Service Stations.)

To find an authorized Service Center nearest you, please turn to page ____.

For Warranty information, please turn to page ____.

Thank you for your choice!

Content

1. Safety Instructions

User Guide	5
Child Safety	5
Precautionary Items	6,7
Power Supply for the Robot	7
Battery Charging, Replacement and Disposal....	8
Recycling Packaging Material	8
When the Product has Problems	8
Correct Disposal of Product	8

2. Packed Contents and Product Specifications

Packed Contents.....	9
Product Specifications.....	9
Part Name.....	10
Unpacking and Installing Filters.....	10
Remote Control Panel.....	11

3. Remote Control

Installing Batteries.....	11
Use.....	11

4. Charger Dock

Assembling Charger Dock.....	12
Placement of Charger Dock.....	12,13
Charging Robot's Battery.....	13

5. Operation and Programming Robot

LCD Panel.....	14
Turning Robot ON.....	14
Pause Mode.....	15
Turning Robot OFF.....	15
Setting Air Schedule Cleaning Time.....	15
Setting Clock Time.....	16
Setting Frequency of Scheduled Air Cleaning Time.....	16

6. Mode Selection

Auto Mode.....	17
Search Mode.....	18
Spot Mode.....	18
Back to Charge Mode.....	19
Demo Mode.....	19
Raise/Lower Mode.....	19
Music Mode.....	19

7. Magnetic Tape

Various Uses for Magnetic Tape.....	20
Application of Magnetic Tape.....	20,21

8. Using Robot.....

9. SD Card.....

10. Maintenance

Cleaning Robot.....	22
Cleaning Filters.....	22
Cleaning Drop Sensors.....	22
Cleaning Charger Dock.....	23

11. LCD Icon Alarm Definitions.....

12. Common Failures.....

13. Common Questions with Answers.....

1. SAFETY INSTRUCTIONS

Please follow these basic Safety Instructions to best assure you or the product is not harmed in the initial set-up and use of the product. Should at anytime you have any questions, please call our 1-800 number for assistance.

User Guide

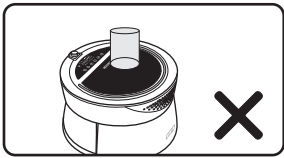

- Be careful in unpacking the product so as not to loose or break anything.
- Immediately dispose of all plastic bags before reading these **Safety Instructions** to prevent children from playing with the bags.
- Do **NOT** dispose of the rest of the packaging material until you check the Instruction Book to make sure you have all the contents. Reference page 9 for list of contents.
- Read the Instruction Book carefully and use your Robot according to the detailed instructions. Store this Instruction Book in a convenient place for easy reference by all users.
- Do **NOT** use the top of the Robot as a place to rest items or a drink. If the Robot gets **WET**, it may destroy the interior electrical components and require service.
- Do **NOT** sit or stand on the Robot **NOR** use as a footrest.
- Do **NOT** press **HARD** on the LCD as you may damage or break the glass. Please do **NOT** touch the LCD if it is broken to avoid injury to yourself.
- Improper operation of the Robot may cause injury to a person or may require your Robot to be serviced by a Service Technician.
- **Not** to be used to filter live cigarette smoke as a hot ash from the cigarette could ignite the filter.
- Use in the Outdoors, Business or in areas with combustibile material is **prohibited**. It will void your Warranty.



The Magnetic Tape may **NEVER** be used to confine an elevated area where the Robot could fall down and hurt a person or cause considerable damage to the room below when the tape has lost its magnetism power.



- In keeping with our name ECOVACS, we strongly urge you to recycle the packaging materials.
- Attempt to repair or alter the operation of this Robot will void the warranty and may allow damage to be done to your property or yourself. All repair work must be done by a qualified Service Technician. Call our 1-800 number for the nearest Service Station to you.

Child Safety



- The Robot is **NOT** a toy and children should **NOT** be allowed to play with it.
- Children should **NOT** be allowed to be alone in the same room that the Robot is operating.
- Adult supervision is required at all times when the child is in the same room the Robot is operating in.

Precautionary Items

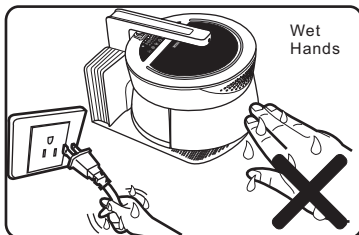
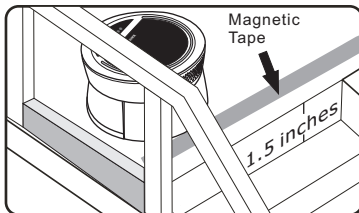
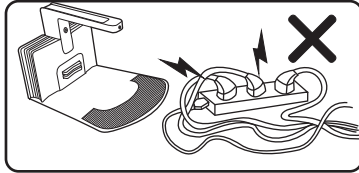
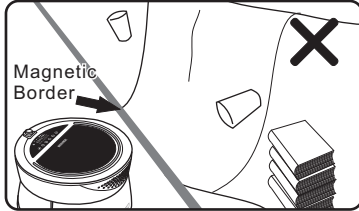
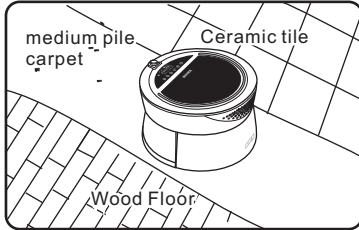

- We recommend the first time you use your Robot you be present to make sure there are no obstructions which might cause a problem to either the Robot or the objects in your home.
- If Pets are part of the everyday household activity, you need to observe how the Pet and the Robot inner act with each other.
- Following precautions should be taken to prevent accidents from happening while your Robot is working:
 - Objects easy to knock over should be removed from the path or magnetic tape used.
 - Table cloth, curtains, and throws should be kept off of the floor so they will **NOT** obstruct the Robot's freedom to move within the room.
 - Power cords for lamps, radios, TV, etc., must **NOT** lie in the path as they might be damaged by the Robot or become entangled with the Robot and cause damage to the Robot or pull the item from its resting place.
 - Objects such as magazines, newspapers, socks, etc., may obstruct the Robot during use or cause damage to the product.
- People in the home should be informed when the Robot is functioning, especially those who maybe hard of hearing or have poor eyesight.
- Charger Dock should be kept in a space where people will not easily trip over when walking in the room.
- Robot cannot detect a staircase if the height is less than 1.5 inches. Also, if the top step of the staircase has a reflective surface such as mirror, glass, marble, tile, etc., it may cause the Drop Sensor not to function and cause the Robot to fall down the stairs. We strongly recommend that you operate the Robot at the Staircase or Step to make sure the Robot can detect the drop off. Should you find that the Robot does not detect the Step or Staircase, then you must place a piece of magnetic tape at the edge to the bare surface, **NOT** on carpet and to make sure the tape will **NOT** cause a person to trip over and fall down the steps.
- Keep **WET** hands from the plug or Robot.

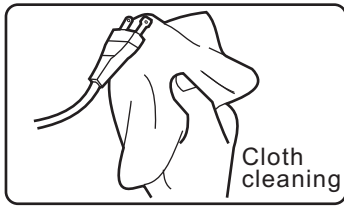

Use a DRY soft cloth for daily and weekly cleaning of the plug, cord, Charger Dock and Robot. A damp soft cloth that has been rung dry of water could be used to wipe the surfaces for better cleaning. A WET cloth may NOT be used as water may get into the Robot or Charger Dock and cause electrical problems resulting in a Service Call.

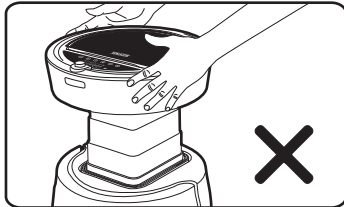
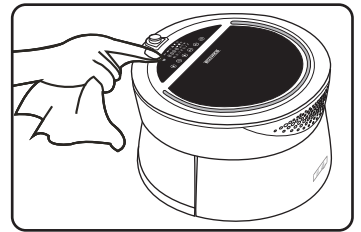

- Do NOT grasp the upper portion of the product as doing so may cause damage to the product.

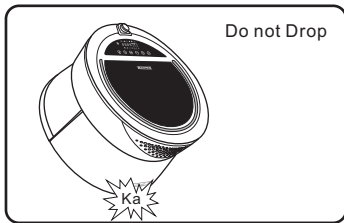

- Do NOT drop the Robot, should this happen, run the Robot to see that everything is okay before letting it operate by itself without you being present.



- Keep the Robot away from hot sources such as heater, fireplace, radiator, kitchen oven, direct sunlight, etc., as the plastic could become distorted and discolored.

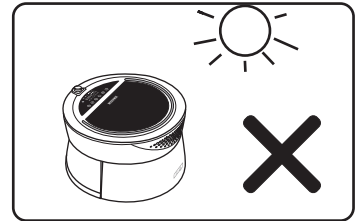

Power Supply for the Robot

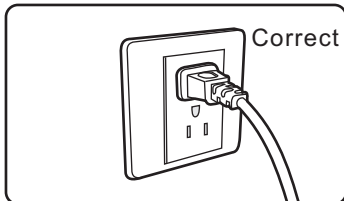

- The Robot's power supply is from a NI-MH rechargeable battery and only accompanying ECOVACS' Charger Dock may be used.

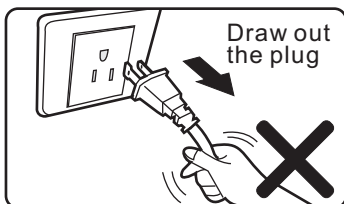

- Do NOT use the Robot if the power supply cord to the Charger Dock becomes damaged. Call our 1-800 number or visit our Web Site for the nearest Service Center to send the Charger Dock for repair.
- Do NOT remove the plug from the wall receptacle by pulling on the power supply cord as it may damage the cord or internal wiring. Grasp the plug to remove from the receptacle.

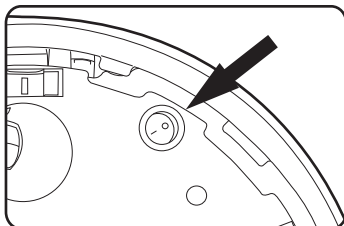

- Do NOT move the Charger Dock by pulling on the power supply cord as you may damage internal wiring.
- Do NOT twist or pinch the power supply cord to avoid damage to the insulation.
- Keep power supply cord away from warm/hot places or sharp edges to avoid damage to the insulation.
- Turn the Robot OFF and remove the Charger Dock plug from the receptacle when you are not using the Robot for an extended period of time.

Battery Charging, Replacement and Disposal



- Approved ECOVACS battery and Charger Dock must be used to prevent potential danger and damage to the Robot, and to **NOT VOID** the Warranty.
- Call our 1-800 number or visit our Web site to order replacement parts. Model and serial number will be required when ordering.
- ECOVACS, being an environmental friendly company, asks you to dispose of used batteries in compliance with your local environmental legislation, as the batteries hazardous substance will pollute the environment.

Recycling Packaging Material



- Please recycle the packaging material in accordance with your local guidelines.

When the Product Has Problems

- Should the power supply cord become damaged, do not attempt to repair by yourself.
- Should the Robot stop functioning, reference pages 24, 25 and 26 in this Instruction Book or call our 1-800 number to talk to an experienced Technician.
- As with the power supply cord, should the Robot require service, please have a certified Service Technician handle your repair. Otherwise, your Warranty will be void and you could possibly cause yourself or your property damage by attempting to do it yourself.

Correct Disposal of Product



- This marking indicates the Robot and Charger Base should **NOT** be disposed with other household wastes throughout the EU. To prevent possible harm to the environment or human health from uncontrolled waste disposal, recycle responsibly to promote the sustainable reuse of material resources. To return your used device, please use the return and collection systems or contact the retailer where the product was purchased. They can take this product for environmental safe recycling.
- In the U.S., please dispose of product at an accredited disposal site in compliance with your local requirements.

2. Package Contents and Product Specifications

Packed Contents

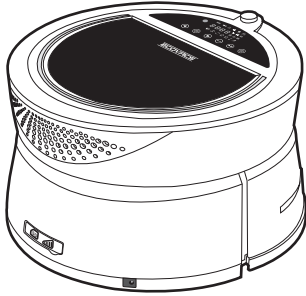

Main Robot

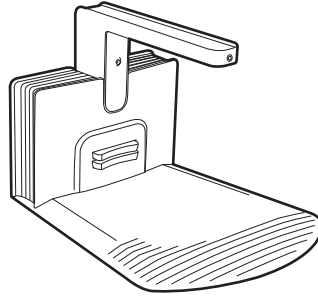

Charger Dock



Remote Control

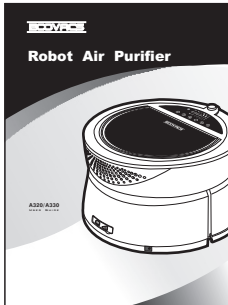

User Guide



Magnetic Tape



Magnetic Recovery Tool



Batteries for Remote Control

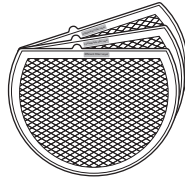

Three Filters

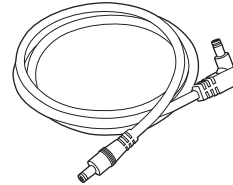

Charging Cable

Product Specifications*

Functional Parameters	Model A320	Model A330	Charger Dock	Model A320	Model A330
Working Voltage	12VDC	12VDC	Input Voltage	220-240V~	220-240V~
Rated Power	24W	24W	Frequency	50Hz	50Hz
Maximum Lifting Height (INCHES)	/	18.5	Rated Output Voltage	15VDC	15VDC
Continuous Working on One Charge		Approximately two hours	Approximately two hours	Rated Output Current	1.6A
Charging Time	Approximately 4-5 hours	Approximately 4-5 hours	Remote Control	Model A320	Model A330
Noise**	≤60dB	≤60dB	Input Voltage (Remote Control)	3VDC	3VDC
			Remote Control Distance	< 16 Feet	< 16 Feet

* Our Company reserves the right to make technological and design changes as a result in pursuing Continuous Improvement. The right of interpretation of the data belongs to ECOVACS Electrical Co., Ltd.

** The data is collected by our companies' laboratory based on noise test and in accordance with IEC 60704-1:1997. IEC 60704-2-1:2001 International Standard. Noise is different based on environmental conditions existing at the time in your setting.

Part Name

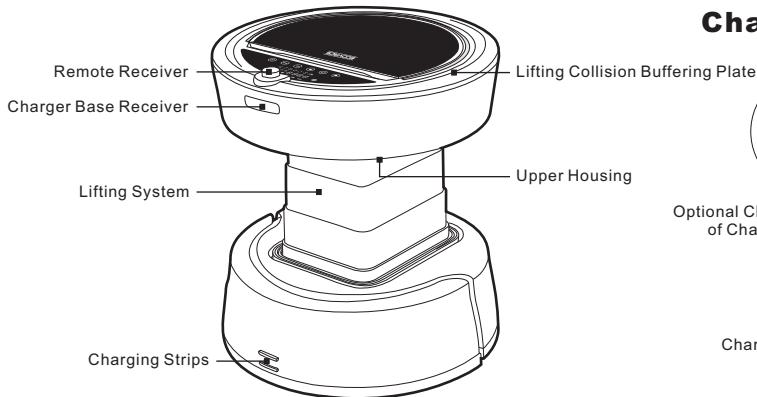
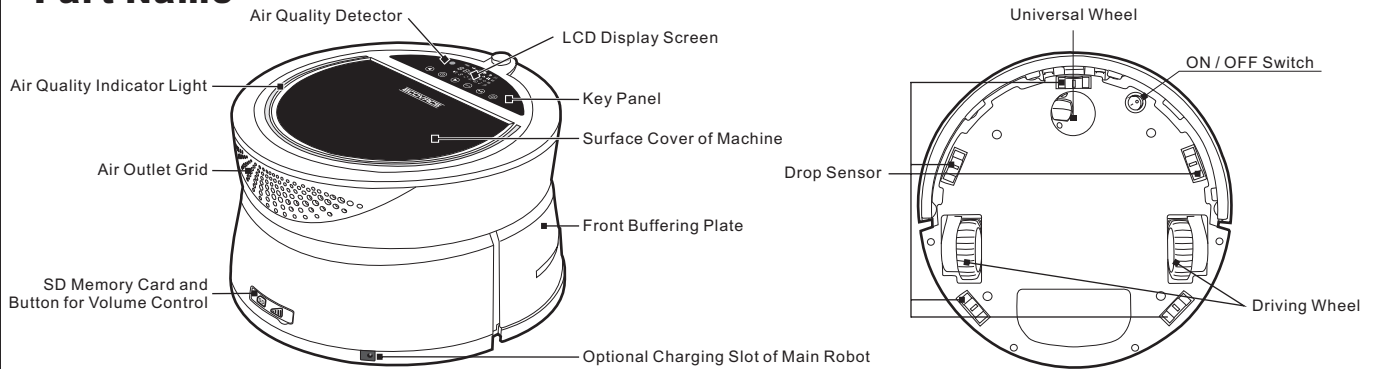

Charger Dock

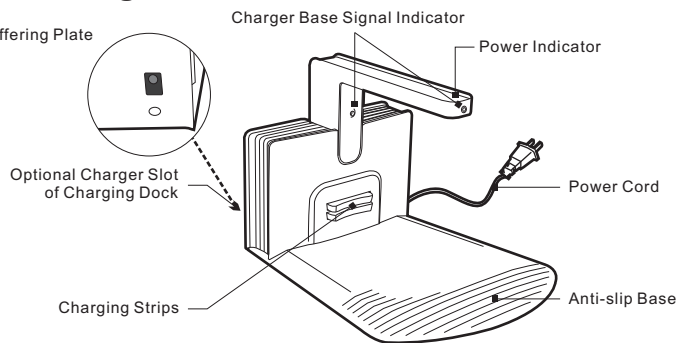

Unpacking Filters

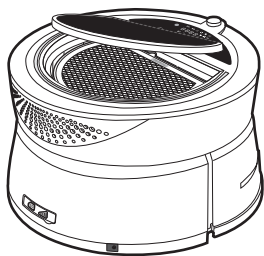

- Open the top of the Robot and remove the filters. Install the filters in the proper sequence.

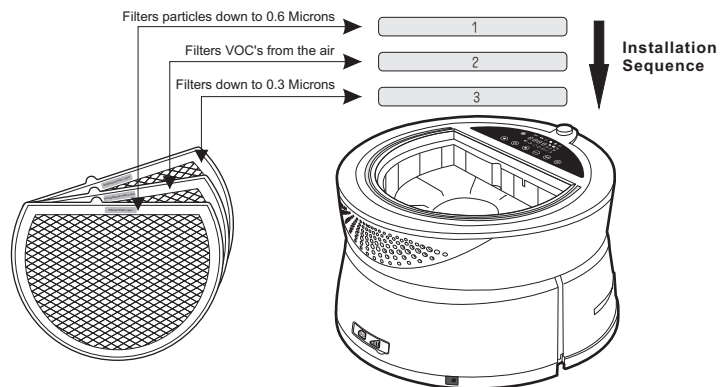

Remote Control Panel

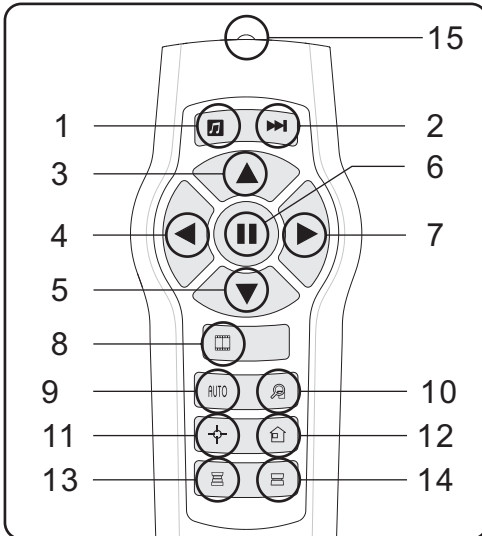

- | | |
|--------------------------|--------------------------|
| 1. Music Mode | 9. "Auto" Mode |
| 2. Play Next Song | 10. Exact Search Mode |
| 3. Machine Move Forward | 11. Fixed Spot Mode |
| 4. Machine Turn Left | 12. Back to Charger Dock |
| 5. Machine Move Backward | 13. Raise Head |
| 6. Machine Stop | 14. Lower Head |
| 7. Machine Turn Right | 15. Remote Signal Beam |
| 8. Auto Demo | |

3. Remote Control

Installing Batteries

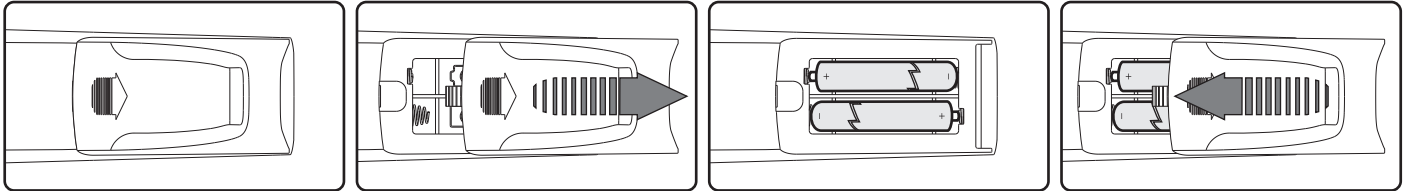

- Remote control uses two (7#) batteries.
- When installing the two batteries, be sure to note the direction of positive and negative polarities.
- If the batteries are low on energy, please replace both batteries so Remote will work properly.
- Properly dispose of batteries in accordance with local legislation.
- If the Remote is **NOT** going to be used for an extended period of time, please remove the batteries so the Remote will **NOT** become damaged.

Use:

- To use the Remote, you must be within 16 feet and point it towards the Indicator light on top of the Robot.
- If the Robot is close to the Charger Dock, the signal from the Charger Dock may interfere with the use of the Remote.
- The Remote may **NOT** work in certain areas where a wireless product is operating. The wireless signal may block the use of the Remote.
- Do **NOT** use the Remote to force the Robot to go over a drop off. This will cause damage to the Robot, to your property and perhaps injure a person in the close vicinity of the product.
- Do **NOT** place the Remote in a hot place or in direct Sun light as the Remote may become damaged.
- Do **NOT** expose the Remote to water or allow debris to become lodged around the buttons or inside when replacing the batteries as this could cause damage to the Remote.

4. Charger Dock

Assembling Charger Dock

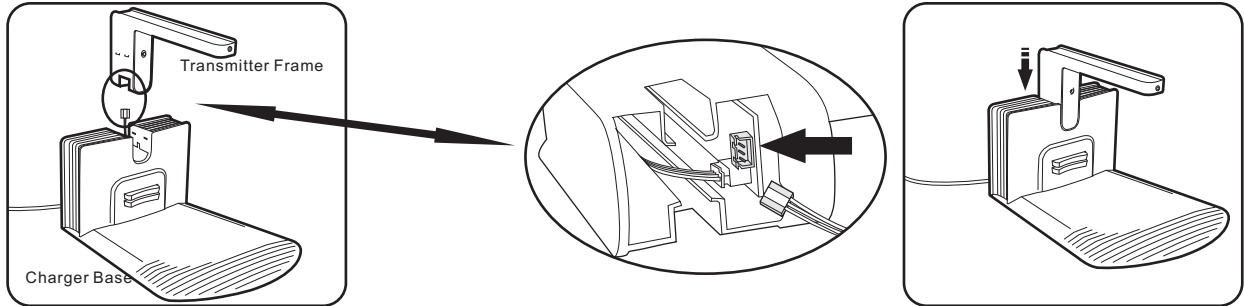

Remove the Charger Base and Transmitter frame from the carton. Looking at the pictures, connect the wire from the base to the frame and then carefully insert the frame, keeping the wires from being pinched, until you hear a "click" sound. This "click" sound indicates the frame is securely latched into the base. Please check by gently grasping the frame and the back and trying to pull upwards.

Placement of Charger Dock

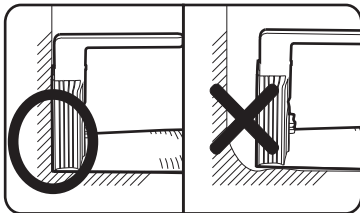

- Place the Charger Dock against the wall according to the picture. It must be placed close to a Receptacle so the Charger Dock's power supply cord will reach.

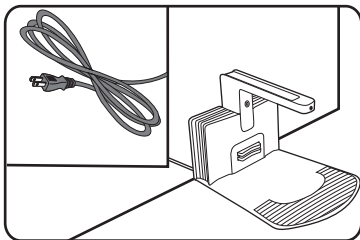
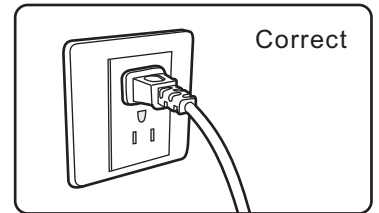

- Any excess power supply cord must be bundled and made secure so not to interfere with the return of the Robot. The power cord may **NOT** be placed under the Charger Dock as it will affect the Robot's return to the Charger Dock.

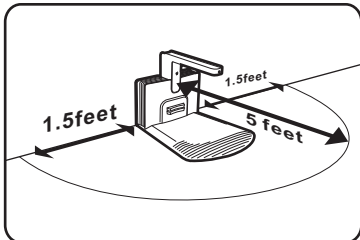

- Please ensure there are **NO** obstacles within a rectangular box of 5 feet and 1.5 feet on each side of the Charger Dock so the Robot can easily find the Charger Dock to recharge the battery. A reflective surface, such as mirror, glass, etc. should **NOT** be directly opposite the Charger Dock so that it will **NOT** affect the infrared signal and keep the Robot from finding the Charger Dock. Do **NOT** place close to stairs as it will affect its ability to Dock or even fall down the stairs.

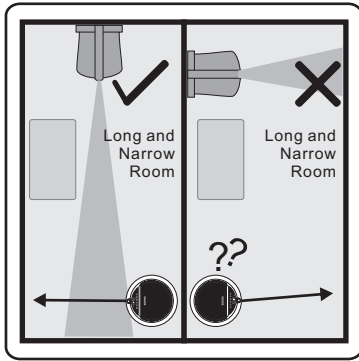

- The Charger Dock should be placed in the room so the Robot can find the Charger Dock's beam as quickly as possible and follow the beam to the source.

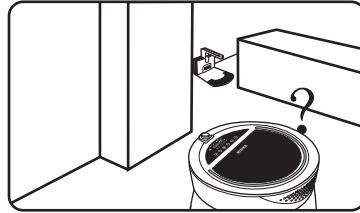

*The room layout is too complicated; therefore, the machine cannot quickly find the Charger Dock.

- Depending on the room size and the number of pieces of furniture in the room, it may take a while for the Robot to find the Charger Dock. If you find this to be happening, you may want to relocate the Charger Dock to a new spot to see if the Robot can find it easier.



Warning:

Do **NOT** place the Charger Dock near stairs or a drop off as it may affect the automatic return for charging and may cause the Drop Sensor from properly functioning.
Do **NOT** place in a well traveled path by people of the household.

Charging Robot's Battery

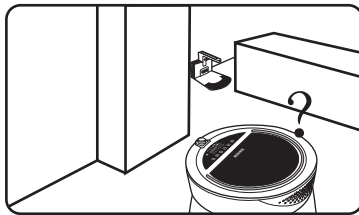

*The room layout is too complicated; therefore, the machine cannot quickly find the Charger Dock.

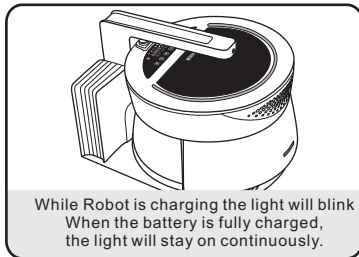

While Robot is charging the light will blink
When the battery is fully charged,
the light will stay on continuously.

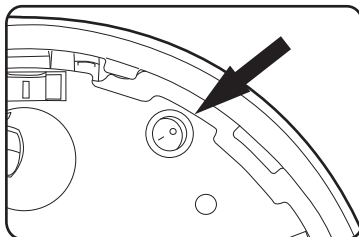

- Before using for the first time, charge the Robot for a minimum of 5 hours. Run the Robot until it wants to seek the Charger Dock to recharge. Do this for 2 or 3 times to achieve the best performance for the battery.
- In normal use, the charging time is about 4-5 hours.
- A warmer or cooler room may require a longer charging time.
- When the Robot's battery gets low during use, it will quit cleaning the air and seek out the Charger Dock for recharging its battery.
- While the Robot is charging in the Charger Dock, the Battery Icon will blink. Once the Robot's battery is fully charged, the Battery Icon will quit blinking and stay on continuously.
- So the Robot is ready to go out and clean the air at anytime, you may leave the Robot in the Charger Dock. Once the battery is fully charged, the current will decrease for charging the battery so that it will not hurt the battery.
- When the Robot is placed in the Charger Dock, the Robot will automatically turn itself **ON** and go in to the **PAUSE** mode where it will wait for the next scheduled air cleaning.
- If you have set the purification "on a schedule" in advance, the Robot will automatically exit from the Charger Dock to work in the "Auto Mode" when the scheduled time arrives.
- If Robot is **NOT** going to be used for 1 or 2 months, unplug the Charger Dock and turn the Robot **OFF** with the switch on the bottom of Robot. When you want to use the Robot again, we suggest you recharge the battery as mentioned above to regain best performance for the battery.

5. Operation and Programming Robot

LCD Panel

The detailed indication of display screen and control panel:

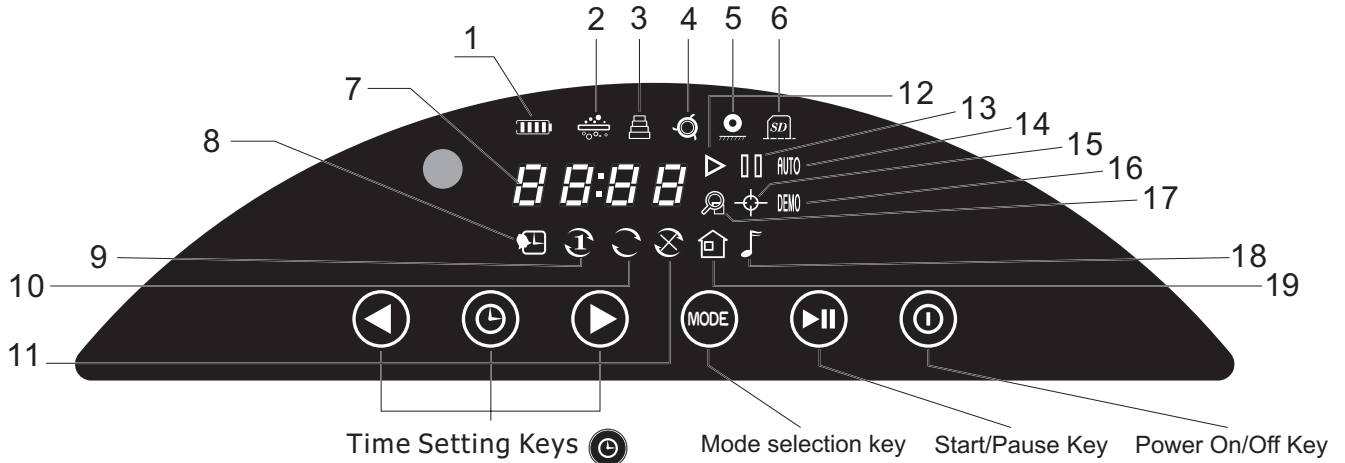

- | | | | |
|---------------------------------------|-----------------------------------------------------------|--------------------------------------|--------------------------|
| 1. Battery Charge Status | not resting on floor. | current day | 14. Auto Mode |
| 2. Prompt for Lack of Filter Material | 6. Prompt for whether the Memory Card Is Installed Or Not | 10. Purification Scheduled Every Day | 15. Spot Mode |
| 3. Prompt for Lifting System Stuck | 7. 24 Hour Time Display | 11. Purification Schedule on HOLD | 16. Automatic Demo Mode |
| 4. Prompt for Driving Wheel Tangled | 8. Prompt for Display of Scheduling | 12. Indication of Working Status | 17. Search Mode |
| 5. Prompt for Driving Wheel | 9. Purification scheduled for | 13. Pause Mode | 18. Music Mode |
| | | | 19. Back to Charger Dock |

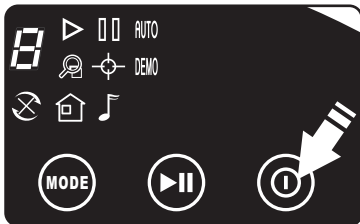
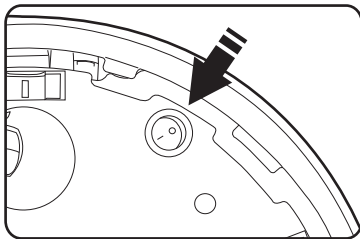

Turning Robot ON



- Turning the Robot over, turn the switch **ON** so the Robot will be able to operate.
- Pressing key on the LCD on the top of the Robot will turn the Robot **ON** and the Robot will be in **stand by** mode.
- Pressing key a second time will turn the Robot **OFF**.

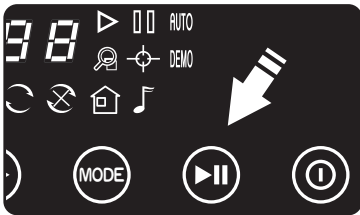

Pause Mode

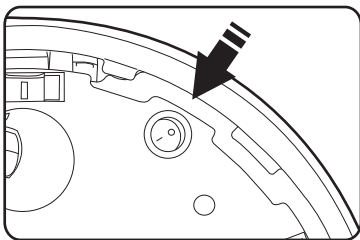
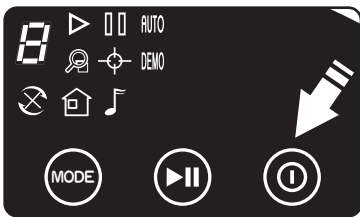

- Pressing the Pause  Mode, you will **Pause** the operation of the Robot.
- During the Pause Mode, you can select one of the various operating Modes.
- Pressing the  key again will start the Robot in the operating mode you selected.
- You may press **any** key on the LCD to cause the Robot to enter the **Pause Mode**.
- With the Robot in the **Pause Mode**, the Robot is **consuming power** from the battery.

Turning Power OFF



- With the Robot running, pressing the  key will turn the Robot **OFF**.
- With the Robot turned **OFF** and **NOT** placed back in the Charger Dock, the Robot will **NOT** go out at the next set Air Cleaning time.
- If the Robot is **NOT** going to be used for a month or more, it is recommended to turn the Robot **OFF** by depressing the  button on the bottom and unplug the Charger Dock.



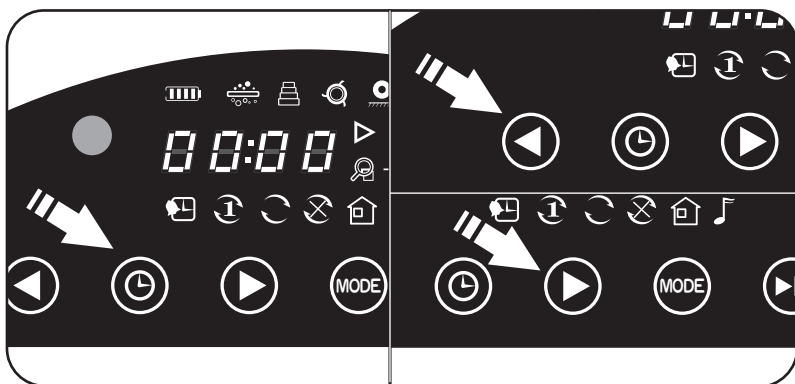





Setting Air Schedule Cleaning Time



FOR EXAMPLE: if the scheduled Air Cleaning Time is to be 1:30 PM then the display on the LCD screen will be shown as 13:30.



NOTE: After you have set the Air Cleaning Time, you will automatically be led into setting the Clock time.

1. With the power  ON, press the Pause  Button.
2. Then press the  Clock Button and hold for about 4 seconds until the 00 are flashing in the LCD. This is the hour section of the clock. The clock is a 24 hour clock.
3. Adjust the hour for the Air Cleaning Time by depressing either  or . Pressing once each time will move the number in the direction you desire for the hour.
4. Press the  Clock Button to set the Hour.
5. The Minute 00 will flash. Set the minute by pressing the  or . Pressing once each time will move the number in the direction you desire for the minute.
6. Press the  Clock Button to set the Minute. The Clock indicator on the LCD will not be lit.
7. The LCD will automatically go to the Clock Set Mode and the 00 will start flashing in the Hour section.

Setting Clock Time

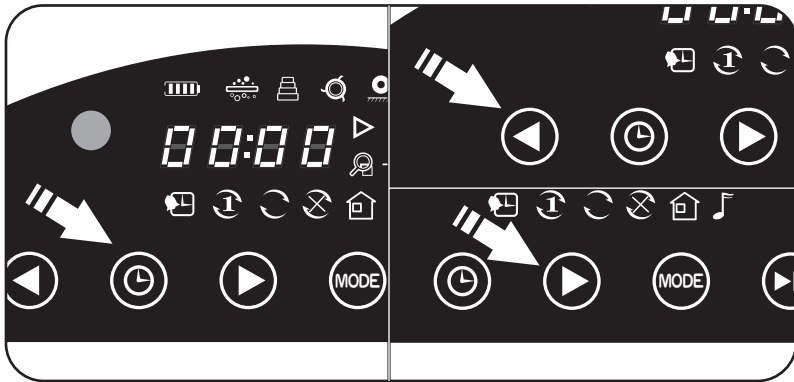

FOR EXAMPLE: if the current time is 3:30 PM, then the display on the LCD screen will be shown as 15:30



8. You are **NOW** in the Automatic Clock set mode, you will see 00 flashing in the Hour section.
9. Set the hour – remember this is a 24 hour clock - for the Clock by depressing either ◀ or ▶. Pressing once each time will move the number in the direction you desire for the hour.
10. Press the ⌚ Clock Button to set the Hour.
11. The Minute 00 will flash. Set the minute by pressing the ◀ or ▶. Pressing once each time will move the number in the direction you desire for the minute.
12. Press the ⌚ Clock Button to set the Minute. The Clock indicator on the LCD will not be lit.

NOTE:

- ▶ If the Robot is turned **OFF** and **NOT** in the Charger Dock, the Robot will **NOT** go out to cleanse the air at the next scheduled time.
- ▶ If the Robot while in the Charger Dock is **NOT** making a good electrical connection to the charger strips, the battery will drain itself and will **NOT** have the battery power to go out on next scheduled time.

Setting Frequency of Scheduled Air Cleaning Time

- Once you have scheduled the time of the day for the Robot to go out and clean the Air, you may select from the following schedule:
 - ▶ one day only
 - ▶ every day
 - ▶ place on HOLD
- Adjust the frequency of scheduled purification by short press of ⌚.
- Looking at the LCD screen, you will see that the clock button is lit and the 1 is lit. This means that the Robot will only do the scheduled Air cleaning once and then **NOT** go out again until instructed. The Robot will return to the Charger Dock when the battery runs low.
- By pressing the ⌚ Clock Button and releasing, the next selection will be lit.
- When this ⌚ is lit, then the Robot will go out every day on the scheduled time and clean the Air, returning to the Charger Dock when the battery runs low.
- By pressing the ⌚ Clock Button again and releasing, the next selection will be lit.
- When this ⌚ is lit, it means it will **NOT** do the scheduled cleaning and will remain in the Charger Dock until you make one of the above selections telling it to do the Air cleaning.

Each time pressing ⌚, this product will carry out icons according to the following sequence:

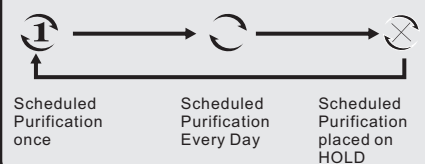



Notes:

- ▶ **ONLY** the **Auto Mode** can be selected to run in the Scheduled Air Cleaning Time setting. Reference page 17 for instructions on how to select this mode.
- ▶ When the Robot starts the air cleaning process, the Robot will raise the top to better clean the air. If the Robot is under a table or a piece of furniture, the top will rise until it meets resistance, where it will immediately stop and start to clean the air. The top can rise to a height of 18.5 inches.

Caution: Because the Robot moves on its own and the top will raise and lower on its own, you must **NEVER** place anything on the top of the Robot.

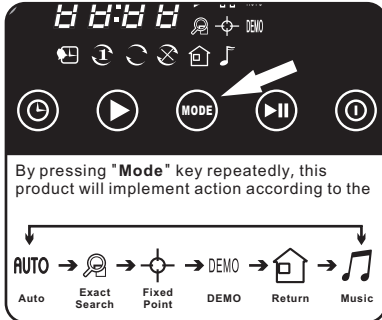
6. Mode Selection



By pressing the MODE  Key, you may select one of the six Modes of operation that you want the Robot to do.

They are: **AUTO**, **SEARCH**, **SPOT**, **DEMO**, **BACK TO CHARGER** and **MUSIC**.

Following is a description of the different modes.

Auto Mode

- This is the only Mode the Robot will run in for the Scheduled Air Cleaning Time.
- When Robot runs in this Mode, the Robot will travel in a straight line to find the Dirty Air. If there is an obstacle in its way, the bumper, upon touching the obstacle, will change direction of the Robot but will still continue to find the source.

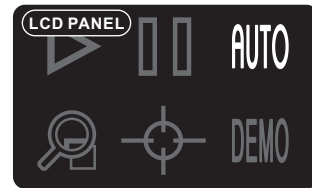
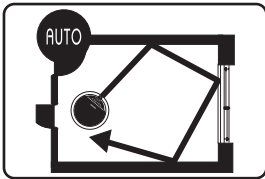

- Once the Dirty Air is found, the Robot will stop, the light on top will change from **Green** to **Red**, the top will extend upwards and the fan will begin to circulate the air through the filters thus beginning to perform the air cleaning process.
- The Robot can operate for up to 2 hours in cleaning the air.
- When the air has been cleaned, the light on top will turn **GREEN**, the top of the Robot will retract and the Robot will move to see if there is Dirty air elsewhere in the room.
- When the Robot detects that the battery is running low, it will stop cleaning the air and return to the Charger Dock for recharging the battery.

Comment:

- ▶ This mode is not restricted by the room size, and will automatically search pollution and perform purification. It is recommended to purify the home air often by using this mode.

- Search Mode** ● Use of this Mode is desired when known air pollution exists and you desire it to go to the source to clean the air.

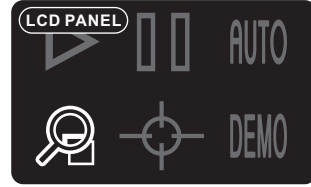
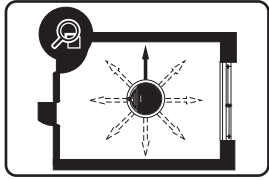

- When Robot runs in this Mode, the Robot will travel to find the source of polluted air. If there is an obstacle in its way, the bumper will activate on touching the obstacle and the Robot will change direction.
- Having found the source of the pollution, the Robot will stop, the light on top will turn from **Green** to **RED**, the top will extend upwards and the fan will begin to circulate the air through the filters thus beginning to perform the air cleaning process.
- The Robot can operate for up to 2 hours in cleaning the air.
- When the air has been cleaned, the light on top will turn **GREEN**, the top of the Robot will retract and the Robot will move to see if there is Dirty air elsewhere in the room..
- When the Robot detects the battery is running low, it will stop cleaning the air and return to the Charger Dock for recharging the battery.

- Spot Mode** ● This Mode  is used when you want to clean the air in a particular area because of various reasons, such as: food preparation in the kitchen, people gathering in a room, people smoking in a room, pet odors, and other strong or offensive odors. You use the Remote to direct the Robot to the Spot desired.

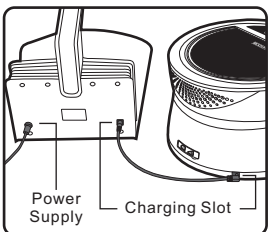
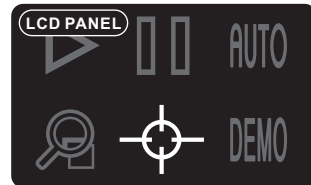
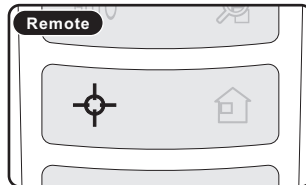
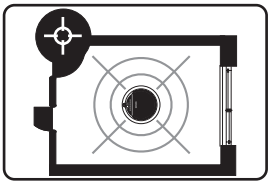



- Under normal conditions, the Robot will clean the air until the air is clean or the battery runs low and the Robot needs to return to its Charger Dock to recharge the battery.
- If a longer duration is required to clean the air, the Charger Dock may be moved to the room and with the provided Charging Cable, connect the Robot to the Charger Dock. This will allow the Robot to run continuously till the air is clean.
- Do **NOT** place the Robot under a table or chair as it will decrease the Robot's ability to cleanse the air.

Note:

For the unit to clean the air on the next scheduled time, the unit **MUST** be set back to the **AUTO** mode and placed back into the Charger Dock.

Back To Charge Mode

- When the Robot's battery runs low, the **Battery** symbol will start to blink; the Robot will stop cleaning the air and will seek out the Charger Dock to recharge its battery.
- At anytime you want to send the Robot back to the Charger Dock, you should press the Pause button and then press the Mode button until the symbol  appears. Then press the Pause  button so the Robot will seek out the Charger Dock.

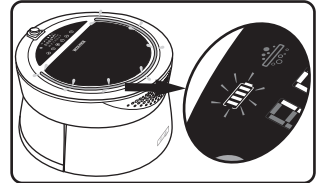
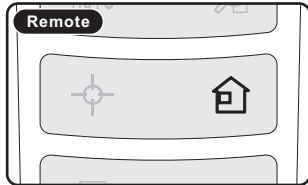
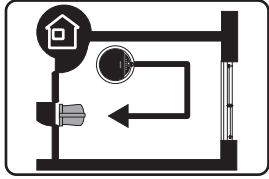

Comments:

- ▶ During the process of charging, **Battery** icon flashes.
- ▶ After the completion of charging, **Battery** icon will stay lit.



Demo Mode

This Mode demonstrates the main functions of the Robot and helps you quickly learn by interacting with the Robot by following the voice commands. Remove Robot from Charger Dock and press  on the **Remote** to start the interaction.

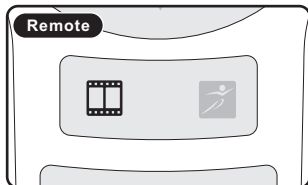
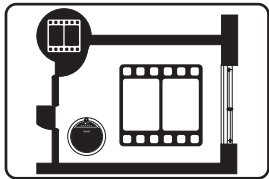
CAUTION: During the **DEMO Mode**, the Drop Sensors are turned **OFF**. The Robot **must NOT** be operated near steps or drop offs as the Robot will **NOT** be able to detect either of these conditions.



Raise/Lower Mode (Only Limited to Model A330)

You may raise  or lower  the head of the Robot by pressing the appropriate key on the **Remote**.

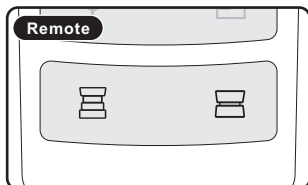
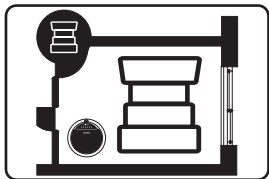

Music Mode

In this mode, you may select the music that you want played by using the Remote. The Robot will play the music while it is in the Charger Dock or out cleaning the air.

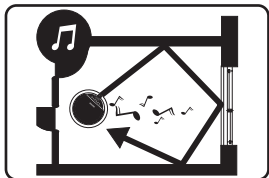

- After selecting this Mode, the Robot will play music.
- You may select the piece of music by depressing the  button on the Remote.

7. Magnetic Tape

Application of the Magnetic Tape to the floor will establish the area you want the Air Purifier to work within.

Various Uses for the Magnetic Tape.

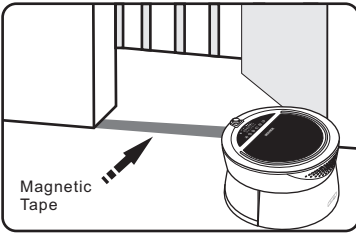

- Magnetic Tape can be affixed to **ONLY** hard floor surfaces when you want to keep the Air Purifier from going in to an area.

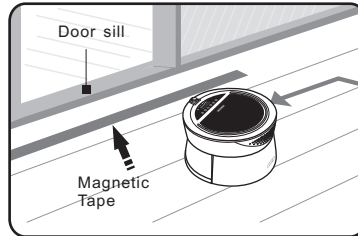

- If the door jam or obstacle is less than 0.4 inch high, the Air Purifier can move over the obstacle. If this is not desired, then Magnetic Tape needs to be applied so the Air Purifier will not attempt to move over the obstacle.

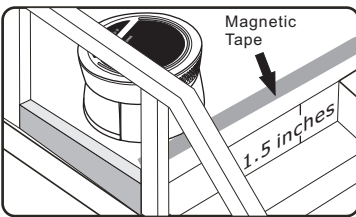

- In case you have stairs or a drop off which the Air Purifier cannot detect because of certain circumstances, you must use the Magnetic Tape. **NOTE:** Be certain that the Magnetic Tape will not cause a person to trip and fall and injure themselves.

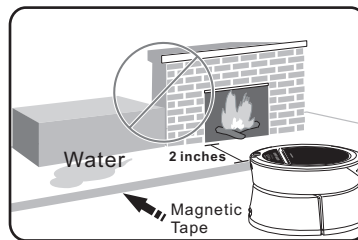

- Do not allow the Air Purifier to operate in areas where there might be water, open Fireplaces, Heaters or fragile glass. The Magnetic Tape can be used to keep the Air Purifier from getting into or close to these areas.

Application of Magnetic Tape

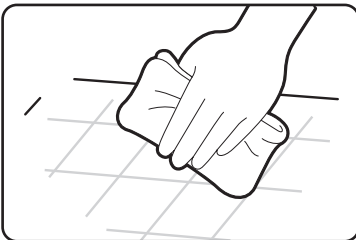

- Use a dry cloth to wipe the area clean of any dirt or dust before application of the Magnetic Tape.

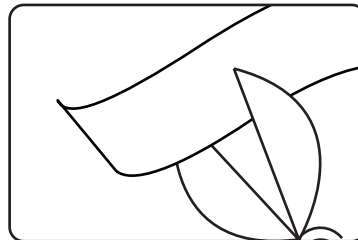

- Remove the Magnetic Tape from packaging, unroll the Magnetic Tape and cut the length required for the location.

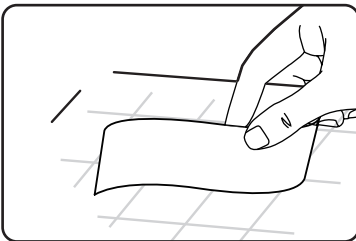

- Being careful, remove **ONLY** the **WHITE** backing off the Magnetic Tape and not the tape itself. Apply the Magnetic Tape to the floor surface, being careful to make sure it adheres to the floor.

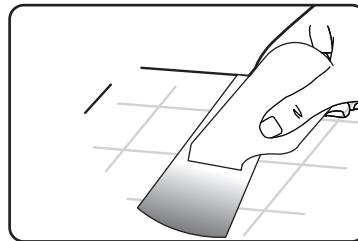

- Using the Magnetic Recovery Tool, swipe the magnetic tape several times to increase the strength of the magnetic tape. You will find that you have to do this to keep the tape up to sufficient strength over a period of time.

Comments:

- ▶ You may use the magnetic tape included in the packaging to keep the Robot in a room for cleaning the air.
- ▶ If a step in the area where the Air Purifier is going to be used is less than 1.5 inches, then magnetic tape must be placed to keep the Air Purifier from falling down the step. **CAUTION**, the tape must be secure so as not to cause a person to trip down the step.
- ▶ The magnetic tape can also be used to define an area where you do **NOT** want the Robot to enter.

- Do **NOT** apply to a carpeted surface as the adhesion will **NOT** be adequate to keep the magnetic tape in position.
- The Magnetic Tape must be applied to a clean dry hard floor surface for proper adhesion.
- After applying the Magnetic Tape, rub the Magnetic Tape with the Magnetism Recovery Tool. This increases the magnetism of the tape.
- The tape should **NOT** be used within 5 feet of the Charger Dock as it will interfere with the Robot finding and entering the Charger Dock.
- The Magnetism Recovery Tool should be used to restore the magnetism of the tape when it is found to be weak.
- There may be residue when you remove the Magnetic Tape. Usually a soapy cloth will clean the area.
- Remaining Magnetic Tape must be stored in a cool, dark place.



- The Magnetic Tape should **NEVER** be used to confine an elevated area where the Robot could fall down and hurt a person or cause considerable damage to the room below when the tape has lost its magnetism power.
- Instead, attach a **permanent guard rail** to block the unit from reaching the edge of the drop off.



8. Using Robot

- With all programming having been completed, you are now ready to use the Air Purifier.
- Having placed the Charger Dock in a room where you want the Robot to operate, place the Robot in the Charger Dock.
- With the Robot turned **ON**, the Robot should automatically go to the Pause Mode and wait for the next scheduled air cleaning time.
- Should no lights light up on the Robot, remove the Robot, turn the Robot over and press the switch to the **ON** setting.
- Place the Robot back in the Charger Dock and the Robot is ready to go out on the next scheduled air cleaning.
- Remember, the **Auto** mode is the only mode the Robot will automatically leave the Charger Dock.
- Remember, we strongly recommend that you be present for the first run of the Robot to make sure obstructions such as cords, magazines, etc. are removed and the Robot will easily find its Charger Dock when it is time to charge its battery.

9. SD Card

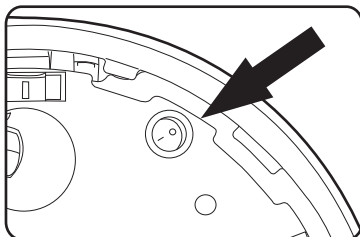

- Before removing the SD card, you must turn the Robot **OFF** by the switch on the bottom of the Robot.
- The SD card will become very **HOT** to the touch if removed after using the Robot, so be very careful in handling the SD card so you **do not burn yourself**.
- Install the SD card to your computer or to an adapter connected to your computer.
- Go to www.ecovacs.com and click on A330 for your language preference. Follow the instructions for loading the music to the web site and then to your SD card.
- Reinstall the SD card the proper way and close the cover.
- Turn the Robot over and press the switch to turn the Robot **ON**.
- With your Remote, you may select the desired song to play.
- Referring to the picture, you may adjust the volume.

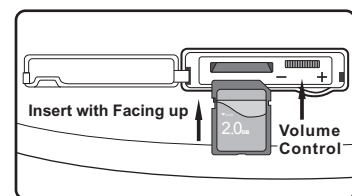
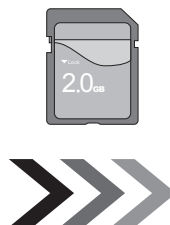
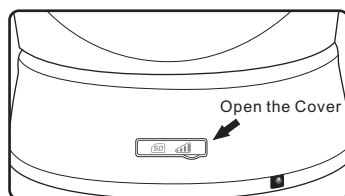

10. Maintenance of Robot Air Purifier

Cleaning Robot

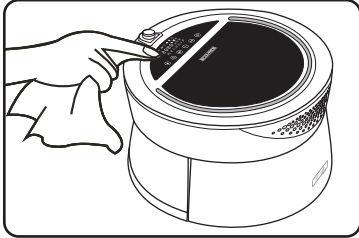

- Turn the Robot **OFF** by pressing the **⏻** Button on the LCD.
- The Robot may be cleaned by using a soft damp cloth with a mild soap solution. The cloth **MUST NOT** be wet, but wrung dry.
- Do **NOT** try to extend the Robot to wipe the tower panels.

Cleaning Filters

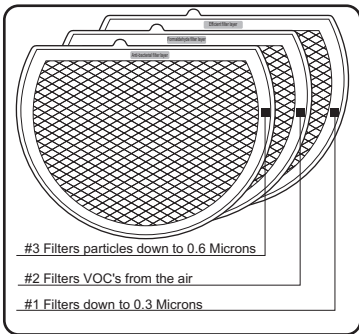

- Remove the Robot from the Charger Dock and press the **OFF** **⏻** button.
- Remove the Top and remove the three filters from the Robot.
- The Top #1 and Bottom #3 filters can be gently tapped on the edge of your wastebasket to remove any debris.
- You may use the hose attachment of your Vacuum cleaner to suck the fines out of the filter. **DO NOT** place the end of the hose or tool directly on the filter material. This could damage the filter and decrease its efficiency.
- The Middle filter #2, can be gently tapped on the edge of your wastebasket to remove any debris. **DO NOT** use a vacuum on this filter as it may cause damage and render the filter useless.
- After thorough cleaning, install the filters back into the Robot with #3 going in first, #2 going in on top of #3 and #1 going in on top of #2.
- Replace the Cover making sure it is securely in position.

COMMENTS:

The #1 and #3 filter may change color after a while. This comes from use. You may check the filters to see if they are still efficient by holding them up to a bright light and if you can **NOT** easily see light through the material, it is time to replace the filters.

The #2 filter should be changed every 6 months or when found that odor filtration is not working well.

Cleaning Drop Sensors

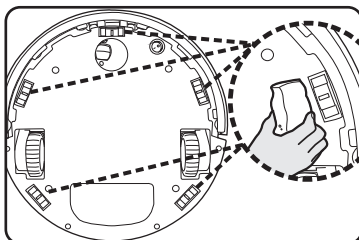

Drop Sensors are located on the bottom of the Robot. Dirty lenses will not allow the sensors to function properly and may cause the Robot **NOT** to detect a drop off or stairs.

- Turn the Robot over onto a flat soft surface.
- You will see five (5) sensors which detect a drop off of more than 1.5 inches.
- These sensors need to be wiped every two weeks or oftener with a soft dry cloth to remove any dust that has been attracted to the lenses.

Cleaning the Charger Dock

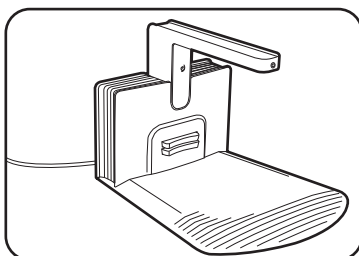





- Unplug the Charger Dock from the Wall.
- Using a damp soft cloth, one that has been wrung dry of water, you may wipe the plug, power supply cord and the Charger Dock.
- Be sure to wipe the sensors with a soft dry cloth before placing back into position and plugging the power supply cord in to the receptacle.



11. LCD Icon Definitions

NOTE:

This product will stop working or fail to start when any of the following symbols are lit on the **LCD screen**.

ICON	CAUSE OF FAILURE	SOLUTION	LOSS of FUNCTION
	Filters not installed in Robot	Remove the top and check that filters are properly installed and in the proper sequence: #1 on Top, #2 in the Middle and #3 on the Bottom.	The Robot will not function properly in cleaning the Air.
	Drive wheel is tangled with hair, piece of cloth, string, etc.	Turn the Robot OFF . Turn the Robot over and remove the item that is tangled with the Drive Wheel.	Robot will not drive
	One or both of Driving Wheels are not in contact with the floor.	By grasping the bottom of the Robot on opposite sides with your hands, gently lift the Robot and place back on the floor so that both Drive wheels are touching the floor.	The Robot will stop its function because one or both wheels are off of the floor and the Robot can not move to perform its function.
	Battery is low on its charge and cannot return to the Charger Dock to recharge its battery.	By grasping the bottom of the Robot on opposite sides with your hands, gently lift the Robot and carry back to the Charger Dock and place in the Dock making sure the Robot makes contact with the Charger Dock by having the lights come ON on top	The Robot has stopped before returning to the Charger Dock because the battery do not have energy left.
	The Robot is not able to raise the Top to the proper height.	Remove the obstacle or press the ⏻ OFF button and gently remove the Robot from under the obstacle.	

12. Common Failure

NO.	Problem	Solution
1	Does not work	<ol style="list-style-type: none"> 1. Turn the power ON by pressing on the LCD panel. Check the Battery icon to see amount of battery energy left in battery. If Battery icon does not light up on the LCD panel, then the battery has no reserve energy. 2. Verify that the Charger Dock is plugged into a wall receptacle. The arm that extends from the Charger Dock should light up with an orange cast. If the arm is not lit, then try another receptacle. If the arm still does not light up, then the Charger Dock should be sent to our Service Center. 3. With the Charger Dock arm lit, place the Robot in the Charger Dock so the contacts rest against the Charger Dock contact. The LCD panel should light up. If the Robot's LCD panel does not light up, then contact our Service Center for further instructions. 4. Check that the switch on the bottom, underneath the Robot, has not been turned OFF accidentally.
2	Machine is not functioning properly	<p>The machine is susceptible to various things found in the average home. Some of these things we might not find during the initial operation or may appear occasionally in later use.</p> <ol style="list-style-type: none"> 1. Cords from lights, TV or other items can become entangled in the Drive Wheels which will cause the Robot to stop functioning until the entanglement is removed. 2. Papers, magazines, clothes, comfort throws, etc. can cause a lifting action with the bottom of the Robot so that the Drive Wheels cannot function. 3. The Robot has maneuvered itself into a tight area so that no matter how it turns, its bumper will run into an obstacle and set it in motion to turn once again. <p>Each of these instances will require personal attention to attend to the Robot and set it in an area to start working again.</p>
3	Machine fails to detect a drop off (Stairs)	<p>The Robot does not detect a drop off and goes over the edge.</p> <ol style="list-style-type: none"> 1. The Drop off could be less than 1.5 inches, or 2. The top of the Drop off (stair) could be reflective, not allowing the sensors to work. <p>The Magnetic Tape needs to be applied to the edge of the Drop Off. Be careful to make sure a person will not trip over the magnetic tape and cause them to fall. Reference page 20 for application of the Magnetic Strip.</p> <ol style="list-style-type: none"> 3. The Drop Sensors on the bottom of the unit need to be wiped free of dust.
4	Air cleaning function is not working or is greatly reduced.	<p>First listen to see if the fan is running, you may also place a piece of tissue at the exhaust exit to verify that the fan is working. If the fan is NOT running, call our Service Center for further instructions.</p> <p>If the fan is running, turn the power OFF on the Robot by pressing Button .</p> <ol style="list-style-type: none"> 1. Remove the Top of the Robot and remove the filters. 2. Clean the filters by referencing page 22 and verify that they are not clogged. 3. Replace the filters by installing in the proper order. 4. Press the  Button and observe the cleaning function. 5. If still NOT working, call our Service Center for further instructions.

13. Common Questions with Answers

1. How long can the Robot function when fully charged?

Answer: The Robot will run for approximately two (2) hours depending on the Mode the Robot is set to clean the air in.

2. What keeps the Robot from falling down when the drop off is greater than 1.5 inches?

Answer: The Robot has five (5) sensors installed in the bottom of the Robot to detect a drop off. The lenses must be wiped with a dry soft cloth every two weeks or oftener to remove dust that can obstruct its function.

3. Why does the Robot not operate for a decent length of time in the selected Mode?

Answer:

- a. The battery may be low on its charge and has to return to the Charger Dock to charge its battery, or
- b. the Robot has sensed the air in its Dirt Sensor and has determined to be clean.

4. How does the Robot react when it meets an obstacle?

Answer: The Robot senses an object and will slow down until the bumper touches the obstacle; this will tell the Robot that it needs to change direction for a new route.

5. Why does the Robot not perform its scheduled air cleaning?

- a. the unit may have been left in a mode selection other than **Auto** mode,
- b. the Robot may have been in the Cancel mode, or
- c. the battery may not have enough energy to do the scheduled cleaning.

6. Why does the Remote Control fail to work?

- a. you may be beyond the 16 foot working range of the Remote.
- b. there maybe other working wi-fi in the room that interferes with the Remote signal,
- c. the lenses on the Remote and the Robot may be dirty and should be cleaned with a dry soft cloth, or
- d. the batteries in the Remote may need to be changed

7. Why does the Robot slow down before stopping?

Answer: The Robot has determined the spot where it should stop and clean the air so the Robot will slow down so that it does not pass the spot.

8. Is there any danger to furniture, children or pets?

Answer: The Robot has a sensor that slows it down when it detects an obstacle in its path; by slowing down, it will make a gentle bump with its vinyl guard and then change its direction. There are no sharp edges so the Robot will not cut a child's skin nor mar the furniture.

9. How to prevent the Drive Wheels from getting tangled in Power Cords?

Answer: Before operating the unit in a room, check that all power cords have been lifted off the floor or placed behind Magnetic Tape.

10. Does it matter if the product stays on the Charger Dock even after it has been charged?

Answer: When the battery is fully charged, the charger will switch to a low current mode and will not deteriorate the battery. Should you not use the Robot for an extended period of time, you should unplug the Charger Dock and turn the Robot off by pressing the Button and turning the switch OFF on the underneath side of the Robot

11. Is there any danger in touching the contacts on the Charger Dock or the Robot?

Answer: The voltage is 24 volts DC and will not cause a problem should a person or animal come in contact with it

12. How can I stop the Robot from going on its scheduled air cleaning while I am away on a trip?

Answer: You may cancel the function. Reference page 16 for instructions.

13. What is the correct way to move the Robot?

Answer: With both hands, grasp the Robot on opposite sides under the Robot. Lift and transport and place back on the floor gently. Make sure when grasping the Robot that you do not accidentally touch the ON – OFF switch that is on the underneath either side of the Robot. You can check that the Robot has power by touching either the PAUSE or the OFF button on the panel or use the Remote.

14. How do I clean the LCD panel?

Answer: Clean with a clean soft cloth and do not press hard on the panel so as not to break the glass. Cleaner used to clean glasses or a TV screen can be lightly sprayed on the cloth to wipe the stubborn spots. Follow by wiping with a dry section of the cloth.

15. Why is there NO music in the MUSIC Mode?

Answer:

1. Check to see that the SD card has been installed in the Robot,
2. Check that the volume has been turned up so you can hear the music, or
3. If still no sound, then call our Service Center for further instructions

16. Why does the Robot fail to return to the Charger Dock?

- Answer: 1. There are objects within 5 feet of the Charger Dock which interferes with the infrared beam
2. There is an object that has a strong reflective surface (mirror) within the infrared beam projection from the Charger Dock that affects the Robot from receiving the Charger Dock beam.
 3. Placement of the Charger Dock does not have a clear view of the room for the infrared beam.
 4. The lenses on the Charger Dock and the Robot need to be cleaned with a soft dry cloth.

17. Why does the Robot not clean the air in the room?

Answer: The pollution has permeated the air in the room and it requires a longer period to clean the air.

18. How to use for longer time under fixed-point mode?

Answer: In this case, you should move the Charger dock to the room and plug the cable into the Charger Dock and the Robot so the Robot will continue to clean the air without using all of the batteries energy. Reference Fixed Point Mode on page 18 for instructions.

19. Why does the Robot take longer in one place than in another to clean the air?

Answer: The Robot has a built in sensor that has a set standard to judge the air quality against. When the air reaches the acceptable limit, the Robot stops cleaning and will move to another location where the air needs cleaning.

20. Why does someone still feel stuffy in the room while the machine keeps looking for air pollution with the indicator light remaining Green?

Answer: This is a normal phenomenon. Sometimes people feel stuffy in a room because lack of air movement. The Robot looks for air pollution and cannot have any affect on the room being stuffy.

21. How to download music?

Answer: Please refer to "Music Mode" in this guide for the specific operation and www.ecovacs.com.cn for downloading the music. Reference page 21 .

22. How do you know when the level of air in your room does not meet acceptable standards?

Answer: The light on top of the Robot will turn RED when the air quality does not meet the Robots standard.

23. There are three (3) reasons why lights will flash/blink

- Answer: 1. When the battery is low on Charge, the Battery Icon will blink
2. Alarm State: When a function does not work, the Icon will blink on the LCD panel until it is fixed.
 3. The light on top will flash RED when the air quality does not meet the Robots set standard; the light will turn GREEN when the air meets the Robots set standard.

24. What are the three status states of the Air Purifier?

Answer: **1. Charging State:** ① In Charging: The power display icon on the display screen flashes. ② After Charging: The power display icon is normally on. **2. Alarm State:** The corresponding alarm indicator icon on the display screen turns red and flashes. **3. Air Quality Display State:** ① The light on Top turns Red when the air does not meet internal standards. ② The light on Top turns Green when the Air meets internal standards.

25. How to activate the battery when not used for a period of time?

Answer: If the battery is dead, place the Robot in the Charger Dock and fully charge the battery. Run the Robot until the battery is low and then place the Robot in the Charger Dock again till fully charged. Repeat this cycle one more time and the battery should function to its full capacity. If the product is not going to be used for more than three months, you should make a note to run the Robot and then charge the battery.

Enjoy Smarter Life!

ECOVACS

A3S-000-IM201101