

Saturn[®]

ST-MW8164

MICROWAVE OVEN WITH GRILL



GB
MICROWAVE OVEN WITH GRILL

Dear Buyer!
We congratulate you on having bought the device under trade name "Saturn". We are sure that our devices will become faithful and reliable assistance in your housekeeping.

Avoid extreme temperature changes. Rapid temperature change (e.g. when the unit is moved from freezing temperature to a warm room) may cause condensation inside the unit and a malfunction when it is switched on. In this case leave the unit at room temperature for at least 1.5 hours before switching it on.

If the unit has been in transit, leave it indoors for at least 1.5 hours before starting operation.

Please read this booklet carefully before fixing and using, and keep it for future reference.

INSTALLATION OF MICROWAVE OVEN

1. Remove the packaging and take out the distance limiter from accessory in microwave oven (some models have been installed already), unlock the power cord, according to the specific shape of distance limiter, install by following the given instruction. The purpose of the distance limiter is to make the microwave oven to keep a certain distance from the wall.

2. Take out all the packing. Carefully check whether there is damage to the microwave oven. Such as:

- a. the oven cavity is impacted or pressured.
- b. the door is not flat; the switch is not smooth and flexible.
- c. the metal Insulated mesh on the door is bent or deformed.
- d. the power cord is loose.

IF IT IS FOUND ABOVE, CONTACT YOUR NEAREST SERVICE CENTER APPROVED.

3. Microwave ovens must be placed under dry and non-corrosiveness environments, kept away from heat and humidity, such as gas burner or water tank.

4. To ensure sufficient ventilation, the distance of the back of microwave to the wall should be at least 10 cm, the side to the wall should be at least 5 cm, the free distance above the top surface at least 20 cm.

5. The position of the oven shall be far from the TV, Radio or antenna to avoid disturbance, the distance at least more than 5 m.

6. The appliance must be positioned so that the plug is accessible, and must ensure a good grounding in case leakage, ground loop can be formed to avoid electric shock.

7. The microwave oven shall not be placed in a cabinet.

8. The back of the oven must be placed against a wall.

9. As there is manufacturing residue or oil remained on the oven cavity or heat element, it usually would smell the odor, even a slight smoke. It is normal case and would not occur after several times use, keep the door or window open to ensure good ventilation. So it is strongly recommended to set the oven to grill mode and operate dry several times.

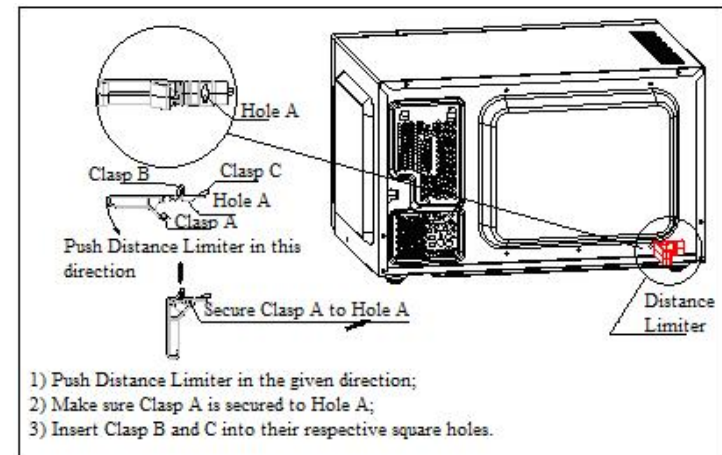

10. To keep the microwave oven at a distance from the wall, it is necessary to install a distance limiter.

WARNING

Operating dry should only be conducted in the grill mode, it should NOT be conducted at combination mode.

UTENSILS GUIDELINE

It is strongly recommended to use the containers, which are suitable and safe for microwave cooking. Generally speaking, the containers which are made of heat-resistant ceramic, glass or plastic are suitable for microwave cooking. Never use the metal containers for microwave cooking and combination cooking as spark is likely to occur. You can take the reference of below table.

Material of container	Micro-wave	Grill	Combination
Heat-resistant glass	○	○	○
Ceramic	○	X	X
Ordinary glass	X	X	X
Heat-resistant plastic	○	X	X
Ordinary plastic	X	X	X
Thin plastic film	○	X	X
Metal grill	X	○	○
Metal container	X	○	○

IMPORTANT SAFEGUARDS

The following basic precautions should always be followed, when using electrical appliance:

1. Read all instructions before using.
2. Make sure the voltage in your living area corresponding to the one shown on the rating label of the appliance. And the wall socket is properly grounded.
3. To reduce the risk of fire in the oven cavity:
 - a. DO not overcook the food.
 - b. Remove wire twist -ties from paper or plastic bags before placing bags in the oven.
 - c. Do not heat oil or fat for deep drying, as the temperature of oil cannot be controlled.

d. After use wipe the waveguide cover with a damp cloth, followed by dry cloth to remove any food splashes and grease. Built-up grease may overheat and begin to cause smoke or catch fire.

e. If materials inside the oven should smoke or ignite, keep oven door closed, turn oven off and disconnect the power supply.

f. Close supervision is necessary, when using disposable containers made from plastic, paper or other combustible material.

4. To reduce the risk of explosion and sudden boiling:

a. Do not place sealed containers in the oven. Baby bottles fitted with a screw cap or teat are considered to be sealed containers.

b. When boiling liquid in the oven, use the wide-mouthed container and stand about 20 seconds at the end of cooking to avoid delayed eruptive boiling of liquids.

c. Potatoes, sausage and chestnut should be peeled or pierced before cooking. Eggs in their shell, whole hard-boiled eggs should not be heated in microwave ovens since they may explode, even after microwave heating has ended.

d. The cooked liquid should not be removed out immediately. Several moments should be waited before removing. In order to avoid possible hazards caused by delayed eruptive boiling of liquids.

e. The contents of feeding bottles and baby food jars are to be stirred or shaken and the temperature is to be checked before consumption, in order to avoid burns.

5. Never operate the oven further if the door or door seals is damaged or the oven is malfunctioned or supply cord is damaged. Return the appliance to the nearest authorized service center for repair and maintenance. Never try to adjust or repair the oven yourself.

6. If the supply cord is damaged, it must be replaced by the manufacturer or its service agent or a qualified technician in order to avoid a shock hazard.

7. After cooking, the container is very hot. Using gloves to take out the food and avoid steam burns by directing steam away from the face and hands.

8. Slowly lift the furthest edge of dishes cover and microwave plastic wrap and carefully open popcorn and oven cooking bags away from the face.

9. To prevent the turntable from breaking:

a. Let the turntable cool down before cleaning.

b. Do not place hot foods or utensils on the cold turntable.

c. Do not place frozen foods or utensils on the hot turntable.

10. Make sure the utensils do not touch the interior walls during cooking.

11. Failure to maintain the oven in a clean condition could lead to deterioration of the surface that could adversely affect the life of the appliance and possibly result in a hazardous situation.

12. Only use utensils that are suitable for use in microwave ovens.

13. Do not store food or any other things inside the oven.

14. Do not operate the oven without any liquid or food inside the oven. This would do damage the oven.

15. This appliance is not intended for using by young children or infirm persons without supervision.

16. When the appliance is operated in the combination mode, children should only use the oven under adult supervision due to the temperatures generated.

17. Any accessories not recommended by the manufacturer may cause injuries to persons.

18. Do not use outdoors.

19. Save these instructions.

20. WARNING: If the door or door seals are damaged, the oven must not be operated until it has been repaired by a competent person;

21. WARNING: It is hazardous for anyone other than a competent person to carry out any service or repair operation that involves the removal of a cover which gives protection against exposure to microwave energy;

22. WARNING: Liquids and other foods must not be heated sealed container, since they are liable to explode;

23. WARNING: Only allow children to use the oven without supervision when adequate instructions have been given so that the child is able to use the oven in a safe way and understands the hazards of improper use;

24. Only use utensils that are suitable for use in microwave ovens;

25. When heating food in plastic or paper containers, keep an eye on the oven due to the possibility of ignition;

26. If smoke is observed, switch off or unplug the appliance and keep the door closed in order to stifle any flames;

27. Microwave heating of beverages can result in delayed eruptive boiling, therefore care must be taken when handling the container;

28. The contents of feeding bottles and baby food jars shall be stirred or shaken

and the temperature checked before consumption, in order to avoid burns;

29. Eggs in their shell and whole hard-boiled eggs should not be heated in microwave ovens since they may explode, even after microwave heating has ended;

30. The oven should be cleaned regularly and any food deposits removed;

31. Failure to maintain the oven in a clean condition could lead to deterioration of the surface that could adversely affect the life of the appliance and possibly result in a hazardous situation;

32. During use the appliance becomes hot. Care should be taken to avoid touching heating elements inside the oven.

33. WARNING: Accessible parts may become hot during use. Young children should be kept away.

34. Do not use harsh abrasive cleaners or sharp metal scrapers to clean the oven door glass since they can scratch the surface, which may result in shattering of the glass.

35. This appliance is not intended for use by persons (including children) with reduced physical, sensory or mental capabilities, or lack of experience and knowledge, unless they have been given supervision or instruction concerning use of the appliance by a person responsible for their safety.

36. Children should be supervised to ensure that they do not play with the appliance.

37. The appliances are not intended to be operated by means of an external timer or separate remote-control system.

38. The temperature of accessible surfaces may be high, when the appliance is operating.

39. Service life - 2 years.



: CAUTION: HOT SURFACE

Household use only

Product description

- 1) Door lock
Microwave oven door must be properly closed in order for it to operate.
- 2) Viewing window
Allows user to see the cooking status.
- 3) Rotating axis
The glass turntable sits on the axis, the motor underneath it drives the turntable to rotate.
- 4) Rotating ring

The glass turntable sits on its wheels, it supports the turntable and helps it to balance when rotating.

5) Turntable

The food sits on the turntable, its rotation during operation helps to cook food evenly.

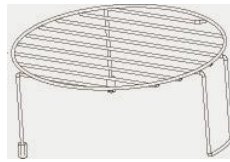

OPERATION OF CONTROL PANEL

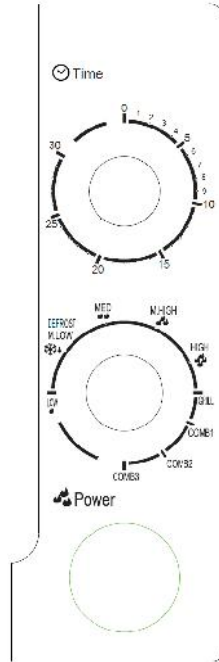

- 1) Timer
 - The max cooking time length that can be set is 30 minutes
 - Each setting is 1 minute
 - A bell ring will be heard when the timer times out and returns to Zero position.
 2) Function / Power knob
 There are 6 power levels:

High	100% power output	(Quick cooking)
M.High	81% power output	(Normal cooking)
Med	58% power output	(Slow cooking)
M.Low	40% power output	(Drinks or soup)
Defrost	36% power output	(Defrost)
Low	18% power	(Keep

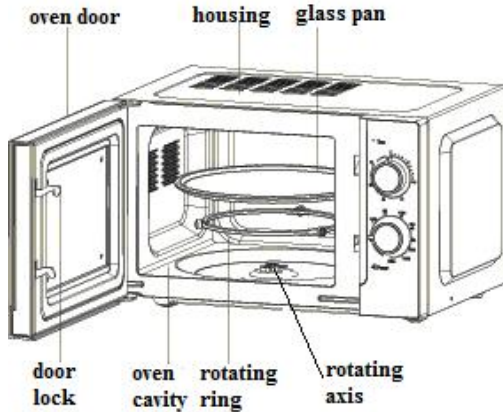

CAUTION

- Place the rotating ring first, and then
- Fit the turntable onto the rotating axis and make sure that it is geared in properly.

6) Control panel

See below in details (the control panel is subject to change without prior notice).

7) Waveguide cover

It is inside the microwave oven, next to the wall of control panel, please see the figure below.

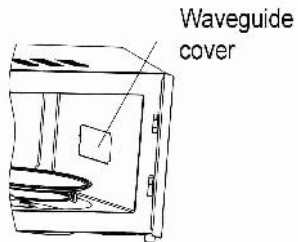

WARNING

Never remove the waveguide cover.

8) Housing

Grill rack is used to place the roasting food.

	output	warm)
--	--------	-------

The following table provides a reference defrost time length for various food:

	WEIGHT RANGE	DEFROST LENGTH
Meat	0.1 ~ 1.0kg	1:30 ~ 26:00
Poultry	0.2 ~ 1.0kg	2:30 ~ 22:00
Seafood	0.1 ~ 0.9kg	1:30 ~ 14:00

Grill -- only heat element is energized. Good brown color will be obtained, even the color makes you mouth water, but if the food is thickly, it may result in the surface of food has been burned, but the center of the food is unbaked. It is suitable for broiling sausage, chicken wings, chops, meat slice, sandwich and etc.

Combination-- magnetron and heat element work in an alternate way. According to the properties of food, utilizing the excellence of Grill and microwave, obtaining the best result.

- Co1: 30% operation time the magnetron is energized and 70% time heat element is energized. Its is suitable for roasting chops, sandwich and etc.
- Co2: 49% operation time the magnetron is energized and 51% time heat element is energized. Its is suitable for broiling small chicken and meat.
- Co3: 67% operation time the magnetron is energized and 33% time heat element is energized. Its is suitable for broiling large chicken, duck and etc.

OPERATION

- 1) Connect the cord.

CAUTION

- Before connecting the cord, make sure the timer is set to "0" position.
 - Do not block the ventilation.
- 2) Place the food on the glass turntable and close the door.

CAUTION

- Food must be contained in a utensil.
- 3) Select the desired power level.
 - 4) Set the timer.

CAUTION

If desired time is less than 10 minutes, turn the timer knob to over 10 minutes

position and then turn back to the desired time setting.

5) Once the desired time is set, the cooking begins. If pausing in between is needed, just open the door at any time, and close it to resume operation

6) When it times out and cooking ends, the microwave oven produces a bell ring, the inside lamp will also be automatically turned off.

CAUTION

If food is removed before time out, make sure to set back the timer to "0" position, this avoids the microwave oven from operating in empty load.

CAUTION

It is recommended to wear gloves, when removing the cooked food from oven and be careful do not touch the heat element on the top of cavity

WARNING

In the mode of Combination/Grill, all of the oven parts, as well as the oven door and top of the oven, may become very hot, do not touch hot surface, use handles or knobs only.

DEFROST TIPS

Microwave penetrates around 4cm into most food, to maximize defrosting effect, the followings are advised:

- 1) For thick and chunky food, turn the food regularly during operation in order to obtain uniform heating effect.
- 2) If food is over 0.5 kg, it is advised to turn at least 2 times.
- 3) Defrosted food should be consumed as soon as possible, it is not advised to put back to fridge and freeze again.

COOKING TIPS

The following factors may affect the cooking result:

Food arrangement

Place thicker areas towards outside of dish, the thinner part towards the centre and spread it evenly. Do not overlap if possible.

Cooking time length

Start cooking with a short time setting, evaluate it after it times out and extend it according to the actual need. Over cooking may result in smoke and burns.

Cooking food evenly

Food such as chicken, hamburger or steak should be turned once during cooking.

Depending on the type of food, if applicable, stir it from outside to centre of dish once or twice during cooking.

Allow standing time

After cooking times out, leave the food in the oven for a adequate length of time, this allows it to complete its cooking cycle and cooling it down in a gradual manner.

Whether the food is done

Color and hardness of food help to determine if it is done, these include:

- Steam coming out from all parts of food, not just the edge
- Joints of poultry can be moved easily
- Pork or poultry shows no signs of blood
- Fish is opaque and can be sliced easily with a fork.

Browning dish

When using a browning dish or self-heating container, always place a heat-resistant insulator such as a porcelain plate under it to prevent damage to the turntable and rotating ring.

Microwave safe plastic wrap

When cooking food with high fat content, do not allow the plastic wrap come into contact with food as it may melt.

Microwave safe plastic cookware

Some microwave safe plastic cookware might not be suitable for cooking foods with high fat and sugar content. Also, the preheating time specified in the dish instruction manual must not be exceeded.

CLEANING & MAINTENANCE

Warnings:

1. It is hazardous for anyone other than a competent person to carry out any service or repair operation that involves the removal of a cover which gives protection against exposure to microwave energy.
2. Remove the power cord from the wall outlet before cleaning.
3. Failure to maintain the oven in a clean condition could lead to deterioration of the surface that could adversely affect the life of the appliance and possibly result in a hazardous situation.
4. The oven should be cleaned regularly and any food deposits removed.
5. Details for cleaning door seals, cavities and adjacent parts.
6. Never use hard detergent, gasoline, abrasive powder or metal brush to clean any part of the appliance.
7. Do not remove the waveguide cover.

TIPS for cleaning:

Exterior:

Wipe the enclosure with a dampened soft cloth.

Door:

Using a dampened soft cloth, wipe clean the door and window.

Wipe the door seals and adjacent parts to remove any spill or spatter.

Wipe the control panel with a slightly dampened soft cloth.

Interior walls:

Wipe clean the interior surfaces with a dampened soft cloth.

Wipe clean the waveguide cover to remove any food splashed.

Turntable / Rotation ring / Rotation axis:

Wash with mild soap water.

Rinse with clean water and allow drying thoroughly.

Servicing

Please check the following before calling for services.

1. Place one cup of water (approx. 150ml) in a glass measure in the oven and close the door securely. Oven lamp should go off, if the door is closed properly. Let the oven work for 1 min.
2. Does the oven lamp light?
3. Does the cooling fan work?
(Put your hand over the rear ventilation openings).
4. Does the turntable rotate?
(The turntable can rotate clockwise or counterclockwise. This is quite normal).
5. Is the water inside the oven hot?

If "NO" is the answer to any of the above questions, please check your wall socket and the fuse in your meter box.

If both the wall socket and the fuse are functioning properly, CONTACT YOUR NEAREST SERVICE CENTER APPROVED.

SERVICING SAFEGUARDS

Caution: MICROWAVE RADIATION

WARNING: It is hazardous for anyone, other than a qualified service technician, to carry out any service for repairing operation which involves removal of any cover which gives protection against exposure to microwave energy.

WARNING: The high voltage capacitor remains charge after disconnection; short the negative terminal of H. V capacitor to the oven chassis (use a screwdriver) to discharge before touching.

During servicing below listed parts are liable to be removed and give access to potentials above 220V to earth.

1. Magnetron
2. High voltage transformer
3. High voltage capacitor
4. High voltage diode
5. High voltage fuse

The following conditions may cause undue microwave exposure during servicing.

- Improper fitting of magnetron;
- Improper matching of door interlock, door hinge and door;
- Improper fitting of switch support;
- Door, door seal or enclosure has been damaged.

IMPORTANT SAFEGUARDS

-- WARNING: If the door or door seals are damaged, the oven must not be operated until it has been repaired by a competent person;

-- WARNING: It is hazardous for anyone, other than a qualified service technician, to carry out any service for repairing operation, which involves removal of any cover which gives protection against exposure to microwave energy.

-- WARNING: Liquids or other foods must not be heated in sealed containers since they are liable to explode;

-- WARNING: Only allow children to use the oven without supervision, when adequate instructions have been given, so that the child is able to use the oven in a safe way and understands the hazards of improper use.

Technical Data:

Power Consumption:	1150 W
Microwave Power:	700 W
Grill Power:	800 W
Rated Voltage:	220-230 V
Rated Frequency:	50 Hz
Rated Current:	5.2
Capacity:	20 l
6 Microwave Power Levels	
Signal Timer:	30 min.

Set

MICROWAVE OVEN WITH GRILL	1
INSTRUCTION MANUAL WITH WARRANTY BOOK	1
PACKAGE	1

ENVIRONMENT FRIENDLY DISPOSAL



You can help protect the environment! Please remember to respect the local regulations: hand in the non-working electrical equipments to an appropriate waste disposal center.

The manufacturer reserves the right to change the specification and design of goods.

RU

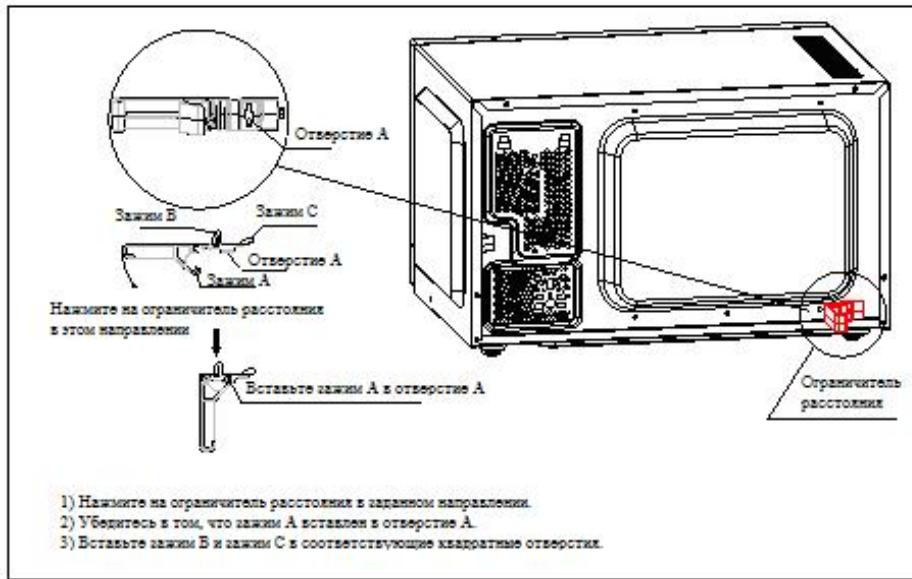

3.

9.

4.

10

5

10.

20

5.

5



6.

7.

8.

10

	-		-
-	0	0	0
	0		
-	0		
-			
-		0	0
-		0	0

4.

20

1.

5.

2.

6.

3.

7.

8.

9.

a.

11

10.
11.
12.
13.
14.
15.
16.
17.
18.
19.
20.
21.
22.
23.
24.
25.

26.
27.
28.
29.
30.
31.
32.
33.
34.
35.
36.
37.
38.
39.

14
- 2



ВНИМАНИЕ: горячая поверхность

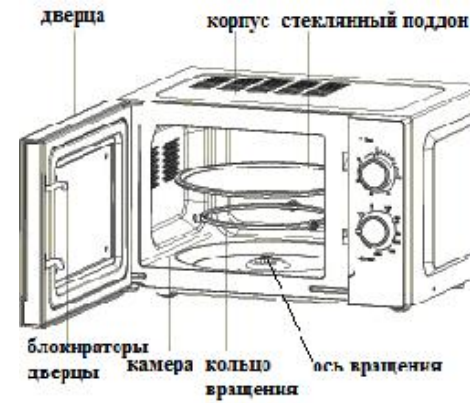

- 1) _____
- 2) _____
- 3) _____
- 4) _____
- 5) _____
- 6) _____
- 7) _____

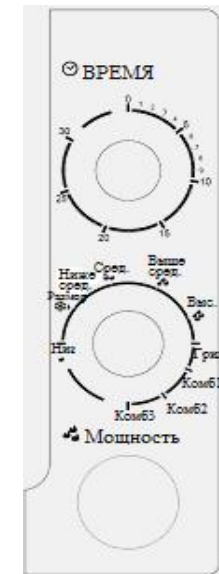
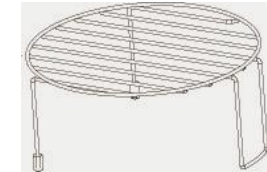

1) 30
1
«0»

2) 6

	100%	
	81%	
	58%	
	40%	
	36%	
	18%	

	0.1 ~ 1.0	1:30~26:00
	0.2 ~ 1.0	2:30~22:00
	0.1 ~ 0.9	1:30~14:00

1) Co1: 30% 70%

2) Co2: 49% 51%

3) Co3: 67% 33%

1)



2)



3)



10

10

5)

6)



«0»



4

1)

2)

0.5

2

3)

1.

2.

3.

4.

5.

6.

7.

1150
700
800
220-230
50
5.2 A
20

"Saturn".

6

30

- 1.
- 2.
- 3.
- 4.
- 5.

- 1
- 1
- 1

1,5

1,5



U

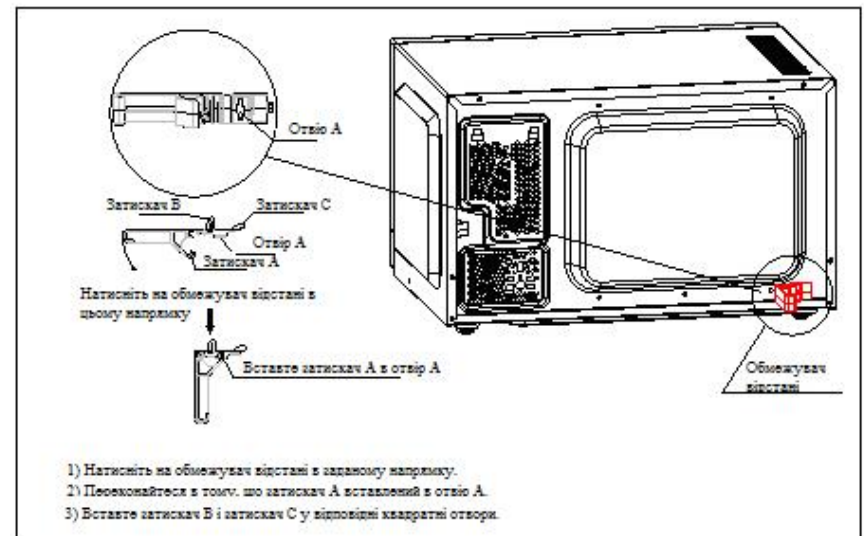

2.

a.

3.

4.

5.

6.

7.

8.

9.

10.



	0	0	0
	0		
	0		

	0		
		0	0
		0	0

1.

2.

3.

4.

5.

6.

7.

8.

9.

a.

10.

11.

12.

20

- 13.
- 14.
- 15.
- 16.
- 17.
- 18.
- 19.
- 20.
- 21.
- 22.
- 23.
- 24.
- 25.
- 26.
- 27.
- 28.
- 29.
- 30.
- 31.
- 32.
- 33.
- 34.
- 35.
- 36.
- 37.
- 38.
- 39.

14

- 2



УВАГА! Гаряча поверхня!

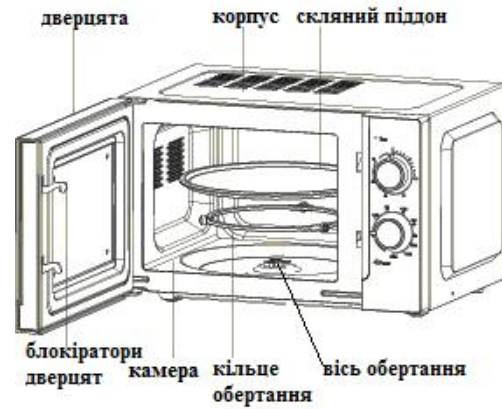

- 1) _____
- 2) _____
- 3) _____
- 4) _____
- 5) _____



- 6) _____ (
- _____).
- 7) _____





8)

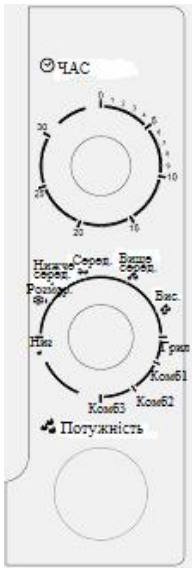
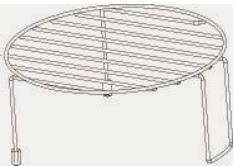

1)

- 1

2)

	100%	-	
	81%		

	58%	
	40%	
-	36%	-
	18%	

	-	-
	0.1 ~ 1.0	1:30 ~ 26:00
	0.2 ~ 1.0	2:30 ~ 22:00
-	0.1 ~ 0.9	1:30 ~ 14:00

1) Co1: 30%

70%

2) Co2: 49%

51%

3) Co3: 67%

33%

1)



"0".

2)



3)

4)



5)

6)



10

10

"0".



!

4

1)

2)

3)

2

0.5

1.

2.

3.

4.

5.

6.

7.

1.

2.

3.

4.

5.

(150)

1

).

).

" "

() (

),

220

- 1.
- 2.
- 3.
- 4.
- 5.



1
1
1

Saturn®

INTERNATIONAL MANUFACTURER'S WARRANTY

,

MEZINÁRODNÍ ZÁRUKA

1150
700
800
220-230
50
5.2 A
20

6

30

INTERNATIONAL MANUFACTURER'S WARRANTY

The Warranty is provided for the period of 2 years or more if the Law on User Right of the country where the appliance was bought provides for a greater minimum warranty period.

All terms of warranty comply with to the Law on Protection of the Consumer Rights and are governed by the legislation of the country where the product was bought.

The warranty and free of charge repair are provided in any country where the product is delivered to by Saturn Home Appliances or authorized representative thereof, and where no restriction of import or other legal provisions interfere with rendering of warranty services and free of charge repair.

Cases uncovered by the warranty and free of charge repair:

1. Guarantee coupon is filled in improperly.
2. The product has become inoperable because of the Buyer's nonobservance of the service regulations indicated in the instruction.
3. The product was used for professional, commercial or industrial purposes (except for the models, specially intended for this purpose that is indicated in the instruction).
4. The product has external mechanical damage or damage caused by penetration of the liquid inside, dust, insects and other foreign objects.
5. The product has damages caused by non-observance of the rules of power supply from batteries, mains or accumulators.
6. The product was exposed to opening, repair or modification of design by the persons, unauthorized to repair; independent cleaning of internal mechanisms etc. was made.
7. The product has natural wear of parts with limited service life, expendables etc.
8. The product has deposits of scale inside or outside of fire-bar elements, irrespective of used water quality.
9. The product has damages caused by effect of high (low) temperatures or fire on non-heat resistant parts of the product.
10. The product has damages of accessories and nozzles which are included into the complete set of product shipment (filters, grids, bags, flasks, cups, covers, knives, sealing rings, graters, disks, plates, tubes, hoses, brushes, and also power cords, headphone cords etc.).

On the warranty service and repair, please contact the authorized service centers of "Saturn Home Appliances".

MEZINÁRODNÍ ZÁRUKA

Záruka se poskytuje na dobu 2 roky. V případě že Zákon na ochranu spotřebitele dané země nařizuje delší dobu, prodlužuje se záruka na tuto dobu.

Veškeré záruční podmínky odpovídají Zákonu o ochraně práv uživatelů a jsou řízené zákonodárstvím státu, kde byl výrobek koupěn. Záruka a bezplatná oprava se poskytují v každém státě, kam jsou výrobky dodané společností „Saturn Home Appliances“ nebo jejím zplnomocněným zástupcem a kde nejsou žádná omezení na dovoz nebo jiné právní předpisy omezující poskytnutí záručního servisu a bezplatné opravy.

Případy, na které se záruka a bezplatná oprava nevztahují

1. Záruční list je vyplněn nesprávně.
2. Výrobek byl poškozen kvůli tomu, že zákazník nesplnil pravidla použití, která jsou uvedena v návodu.
3. Výrobek byl používán k profesionálním, komerčním nebo průmyslovým účelům (kromě modelů speciálně určených pro tyto účely, což je uvedeno v návodu).
4. Výrobek má vnější mechanická poškození nebo poškození, vyvolaná tím, že se dovnitř dostala tekutina, prach, hmyz a jiné cizí předměty.
5. Výrobek má poškození, která jsou vyvolaná nesplněním pravidel napájení od baterií, sítí nebo akumulátorů.
6. Výrobek rozebírali, opravovali nebo měnili jeho konstrukci lidé, kteří nebyli zplnomocněni k opravě, bylo provedeno samostatné čištění vnitřních mechanismů a pod.
7. Výrobek má přirozené opotřebení dílů s omezenou dobou použití, spotřebních materiálů atd.
8. Výrobek má vrstvu usazeniny uvnitř nebo zvenku termoelektrických ohřevů, bez ohledu na kvalitu používané vody.
9. Výrobek má poškození, která jsou vyvolána působením vysokých (nízkých) teplot nebo ohně na termonestabilní části výrobku.
10. Výrobek má poškození příslušenství a nástavce, které jsou dodané spolu s výrobkem (filtry, síky, sádky, baňky, mísy, víka, nože, šlehače, struhadla, kotouče, talíře, trubky, hadice, kartáče a také síťové šňůry, sluchátkové šňůry atd.).

V otázkách záručního servisu a oprav se obraťte na autorizovanou servisní středisko společnosti „Saturn Home Appliances“.

2

«Saturn Home Appliances»

- 1.
- 2.
- 3.
- 4.
- 5.
- 6.
- 7.
- 8.
- 9.
- 10.

«Saturn Home Appliances».

					LCD		
.4	" "	8-988-993-37-78	+		+	+	+
18		8(8553) 32-22-11 8-960-047-22-11	+	+	+	+	+
98	« - »	8(86133) 6-09-84, 8-918-215-57-75	+	+	+	+	+
48, .108	" "	8(3955) 67-00-44, 8(3955) 56-61-77	+	+	+		+
,109	-	8(86152)2-81-99	+	+	+	+	+
.1, .1, 12	« -29»	8(8182) 44-15-55	+				
,47	« »	8(8512)25-19-39 8(8512) 25-12-00	+	+	+		
16,2 .7	« - »	8(8512) 54-67-67, 8(8512) 54-91-91			+	+	+
.15	« - »	8(85141) 3-61-25	+	+	+	+	+
32		8-927-552-47-21, 8-937-122-13-99				+	+
.113	« »	8(3852) 63-94-02	+		+	+	+
.25		8-905-425-60-4-73	+	+	+		

№ 37	-	8(8635) 47-47-72, 8(8635) 47-47-72	+	+	+	+	+
№ 63	« - »	8(86155)3-11-00, 8-918-980-64-75	+	+	+	+	+
№ 84	..	8(86559) 2-08-02, 8(86559)5-29-71	+	+	+	+	+
№ 58	« »	8(8442) 23-41-36, 8(937) 717-93-34	+		+		
№ 173	« - »	8(8442) 97-50-10, 8-960-883-59-00		+			
№ 4	..	8(8442) 98-16-47, 8(8442) 53-06-04	+	+	+	+	+
№ -	« - »	8-961-688-53-48		+			
№ -		8-927-521-52-00		+		+	+
№ 32		8-937-722-68-12				+	+
№ 158		8-937-730-66-03		+		+	+
№ -		8-904-404-14-55				+	+
№ C -	«Master»	8-928-126-63-66	+		+		

77-№ 65	« - »	8(937) 717-93-36	+			+	
№ 65	« - »	8(8172) 70-03-45, 8(8172) 54-21-54	+			+	+
№ 1	« - »	8(8172) 52-72-51	+			+	
№ 46	" - "	8(473) 260-09-08, 8(473) 240-57-73	+			+	+
№ 140/1	- ..	8(87951) 6-47-93, 8-928-654-28-01				+	
№ 48	« - »	8-962-655-20-00	+	+	+	+	+
№ 68	« - »	8(8313) 21-14-14	+			+	
№ 54	« - »	8(8313) 20-93-00, 8(8313) 20-92-94				+	
№ 63	" - "	8(84235) 2-86-59, 8(84235) 9-14-64	+			+	+
№ 84	« - »	8(86132) 2-11-71, 8(86132) 3-66-02	+	+	+	+	+
№ 64	" - "	8(343)240-26-60	+			+	
№ 16	/ " - "	8(343) 201-51-41, 8(343)347-76-83	+	+	+	+	+

47	« »	8(47467) 4-12-08, 8(47467) 4-33-17	+		+		
.45/6	« - »	8(4932) 335185, 8(4932) 335236	+	+	+	+	+
, .4	« - »	8(3412) 3079-79, 8(3412)30-83-07	+		+	+	+
, .76	« - »	8(3412) 78-76-85, 8(3412) 78-06-64	+		+	+	+
7/1, 301, 307	« - »	8(3412) 44-60-40, 8(3412) 44-60-67		+			
7 (« »)	« - 26»	8(86545) 2-74-74		+			
, 24	« - »	8(8362) 24-11-24, 8(8362) 25-55-40	+	+	+	+	
, .20	« »	8(39520) 65-04-95, 8(39520) 93-16-56	+		+	+	
.24	" "	8(3952) 42-55-76, 8(3952) 78-15-83	+		+		
, .38	« »	8(843) 248-71-17, 8(843) 258-85-65	+		+		
, .25, .47	« - »	8 (4842) 54-82-22, 8 (4842) 54-83-33	+	+	+	+	+
33	-	8(3439) 39-95-20, 8(34399)34-74-40	+	+	+	+	+

53/2	-	8(3842) 35-39-67	+			+	
.42	« - »	8(8332) 56-25-95, 8(8332) 54-70-77	+		+	+	
, .9	-	8-988-548-24-36	+	+	+		
5	« - »	8(4942) 300107, 8(4942) 300107	+		+	+	+
, .2,	-	8(86142)4-43-59	+	+	+	+	+
, 3	-	8(861) 267-50-88	+	+	+	+	+
103, .55	« - »	8(861) 222-64-13, 8(861) 222-85-55, 8-905-408-08-38	+	+	+	+	+
, .42/2	-	8-918-041-31-04, 8(86131) 71-2-72		+			+
, .116	-	8(86164) 7-01-22		+			
, .57	" "	8(86145) 3-78-74	+	+	+	+	+
, .25	« - »	8(86164) 65-4-95, 8-918-355-81-70	+	+		+	+
, .1	-	8(86153) 4-16-70		+			

168	" - " -	8(86151) 4-33-54, 8-918-464-00-86	+	+		+	+
1	« - »	8(3912) 93-54-33, 8(3912) 94-52-82	+	+	+	+	+
36-	« +»	8 (4712) 50-85-90, 8 (4712) 35-04-91	+	+	+	+	
	« - »	8 (86169) 7-39-99, 8(86169) 7-24-96	+	+	+	+	+
.66	" "	8(4742) 33-45-65, 8(4742) 33-45-95	+	+	+	+	+
.29	« - »	8 (8772) 52-36-90	+	+	+	+	
25	« - »	8 (8772) 55-62-38		+			+
.20	« - »	8(8722) 93-30-73	+	+	+	+	+
11	« »	8(86385) 2-33-26 8-960-458-07-11	+	+		+	+
.16, .9	« - »	8 (499) 340-29-89, 8 (499) 733-25-00		+			
1534	« - »	8(499) 717-82-07, 8(499) 717-82-12	+		+	+	+
.3 ()	« »	8(495) 721-30-70, 8(499) 168-05-19, 8(499) 168-47-15	+		+	+	+

(30/05)	« »	8(8552) 359002, 8(8522) 359042	+	+	+		
24	" - " -	8(8662) 42-04-30 8(8662) 42-12-21	+			+	+
55	« - »	8(86554) 5-59-77, 8(86554) 3-67-57	+	+	+	+	+
.9 (« »)	« »	8(8555) 48-08-80, 8-917-906-60-06	+			+	+
.21	« - »	8(831) 229-63-66, 8(831) 229-60-87	+			+	+
.18	« - »	8(831) 46-18-848		+			+
.6	« - »	8(831) 46-18-848		+			+
.18	« - »	8 (3843) 20-31-33	+			+	+
.14	« - »	8(8617) 63-11-15, 8(8617) 63-03-95	+	+	+	+	+
17	" - " -	8(383)274-99-33, 8(383) 274-99-45	+			+	
.24		8(86369) 3-74-75, 8-928-609-35-85	+	+	+		
4		8 (3532) 36-87-94	+			+	+
.16	« - »	8(3532) 77-67-64, 8(3532) 78-15-82	+	+	+	+	+

130	" - "	8(3812)36-42-02	+		+	+	+
12	« - +»	8(3537) 33-84-43, 8(3537) 35-13-18	+	+	+	+	+
12	« »	8(8412) 26-09-60, 8(8412) 26-12-29	+		+	+	+
13	« - »	8 (342) 221-40-99	+	+	+	+	+
11	« - »	8(8142) 78-06-93, 8(8142) 70-65-48	+		+		
11	« - »	8 (8112)-53-86-30, 8 (8112)-53-86-50	+		+		
12		8(793) 31-84-16	+	+	+	+	+
5-13	" "	8(8793) 98-70-11	+	+	+	+	+
148	-	8(47396) 48-911	+	+	+	+	+
37	« - »	8(863) 250-47-77	+		+		
50-1/52, 55	« »	8 (863) 21-92-112, 8-800-100-51-52	+	+	+	+	+
11 /17		8-906-453-35-81	+		+		

12	« - »	8(4855) 22-04-77, 8(4855) 25-38-60	+	+	+	+	+
14	" "	8(86370) 2-19-50	+	+	+	+	+
12	" - "	8(4855) 22-04-77, 8(4855) 25-38-60	+	+	+	+	+
21	« - »	8(4855) 24-31-21	+	+	+	+	+
14, 1	« - »	8(4912) 76-88-01, 8(4912) 40-30-30	+	+	+	+	+
42" "	« - »	8(4912) 41-33-02,	+	+	+	+	+
52, 8, 9		8(846) 931-85-46	+	+	+	+	+
63	" - "	8(846) 379-54-54	+	+	+	+	+
197	« - XXI»	8(812) 600-11-97	+	+	+	+	
41,	« »	8(812) 325-36-56, 8(812) 325-36-57	+		+	+	
11, 36	« -95»	8(812) 822-18-00, 8(812) 320-06-61	+				
1	« - »	8(8342) 23-05-91, 8(8342) 47-48-59	+	+	+		

3-	« - - »	8(8452) 35-11-80, 8(8452) 55-43-63	+	+	+	+	+
.167/1		8-951-522-38-11	+	+	+	+	+
253	« - »	8(496) 547-04-95, 8(496) 549-32-79	+	+		+	+
.90	« »	8 (8622)55-51-19, 8 (8622) 55-01-08	+			+	+
.50 .8/1	« »	8(8652) 74-01-91	+	+	+		
63	« »	8(8652) 24-30-14, 8(8652) 23-31-81	+	+	+	+	+
15 .21	« - »	8(8652)95-53-68, (8652)95-61-90				+	
.1	« - - »	8 (4725) 24-62-27, 8 (4725) 24-73-49	+	+	+		
.158	« - »	8(3473) 20-12-13, 8(3473) 20-27-70	+			+	+
.25	« »	8(8212) 22-95-29, 8(8212) 29-12-20	+	+		+	+
137	« -2000»	8(4752) 56-19-42, 8(4752) 56-19-44	+	+		+	+
88/15	-	8-910-834-80-35, 8-952-065-89-10	+			+	

.24/2	-	8(86130) 4-86-59, 8-918-147-02-03	+	+		+	+
.2/2	" -	8(86196) 7-20-53	+	+	+	+	+
.48	« +»	8(8482) 22-72-41, 8(8482) 22-71-85, 8(8482) 61-65-64	+	+	+	+	+
.58	« -2»	8(3822) 56-23-35, 8(3822) 48-08-80	+			+	
.137	« - »	8(4872) 31-12-57	+	+	+	+	+
.55	" "	8(3452) 47-35-69	+			+	+
.28	« »	8(3012) 21-89-63	+			+	+
.18, 18,2	« »	8(8422) 31-00-00	+	+	+	+	+
.16/7	« - »	8(8422)73-44-22, 8(8422) 73-29-19	+	+		+	+
.378	« - »	8(87875) 7-44-82	+	+	+		
.148	« - »	8(3472) 77-12-62	+			+	
.153, .42, .7	« »	8(347) 279-90-70, 8(347) 241-62-02					+
.15	" " -	8(86391) 2-18-06	+			+	

36	« - »	8(8352) 62-30-97, 8(4942) 63-20-98	+		+		
.102 ()	-	8(351) 772-72-05, 8(351) 772-73-66, 8(351) 772-69-01	+	+	+	+	+
.8 ()	-	8(351) 239-39-34, 8(351) 239-39-35	+	+	+	+	+
.18	« - »	8(8202) 54-31-88	+		+	+	+
.340" "	« - »	8(8782) 27-30-60, 8(8782) 27-70-77	+	+	+	+	+
.48, .11	" . ."	8(8782)25-04-66, 8(8782)25-19-15	+	+	+	+	+
.1	-	8-904-345-83-18	+	+	+	+	+
.3- .21	« - »	8 (84722) 9-52-07, 8-937-469-52-07	+	+	+	+	+
.57	« - »	8(8453) 55-80-89, 8-964-848-45-06	+		+	+	+
.12	« - »	8 (4852) 25-94-83	+		+		

UA

- 2
- «Saturn Home Appliances»
- 1.
- 2.
- 3.
- 4.
- 5.
- 6.
- 7.
- 8.
- 9.
- 10.

«Saturn Home Appliances».

				/	-	-
					-	-

1	,36	Hi-Fi	(064) 424-89-50	+	+	+
2	.14		(065)632 21 83, 050-904-57-17	+	+	+
3	,66		062744-60- 38(39)	+	+	+
4	,49	-	(04563) 633-19	-	+	-
5	.50- ,82	-	(045) 63-68-413	+	+	+
6	,57	-	(041) 43-406-36	+	+	-
7	,43	" "	(0314 1) 43-432	+	+	+
8	,3, .8	-	(044) 332-01-67	+	+	+
9	,42	-	(0432) 46-50-01	+	+	-
10	,61		(0432) 61-95-73	+	+	+
11	,16	-	(0432) 464393; (0432) 468213	+	+	+
12	,3		(0432) 64-24- 57, (0432) 64-26-22	+	+	+
13	,1		(0432) 509-191, 579-191	+	+	+
14	,68, 1 , .420		(0562) 337-574	+	+	+
15	17 .130	-	(056) 778-63-25 (28)	+	+	+
16	,59		(0562) 35-04-09	+	+	+
17	,118		(0562) 67-60-44	+	+	+
18	,41		(056) 790-04-60	+	+	+

19	,9		(068) 851-33-33	+	+	+
20	188		(062) 3450607 0953204451	+	+	+
21	,129	-	(062) 349-26-81	+	+	+
22	,1	-	(062) 3027569 (066)5082652	+	+	+
23	,8	" "	(0412) 471-568	+	+	-
24	,4 .222		(067) 410 2198	+	+	+
25	24	C	(0412) 47-07- 42, 42-11-53	+	+	-
26	,50	-	(061) 220-97-65 (64)	+	+	+
27	,175		(061) 701-65-96	+	+	+
28	,83	-	(061)212-03-03	+	+	+
29	,75		066-085-75-39	+	+	+
30	19		(0342)559-525, 750-777	+	+	+
31	14		(0342) 754737	+	+	-
32	,9	-	096-729- 4038,067-484- 9888	+	+	+
33	,76		(04597) 57393	+	+	-
34	,161	-	(04736) 629-49	+	+	+
35	1	-	(044) 591-11-90	+	+	+

36	, . ,1	" "	(044) 4269198	+	+	-
37	,9 .57	-	(044) 369-5001 (063) 486-6999	+	+	+
38	,10		(06272) 2-62-23, (050) 279-68-16	+	+	+
39	,1	" "	(0522) 301-456	+	+	+
40	,2		(0522) 35-79-23	+	+	+
41	,98	-	(0522) 270-345,349-585	+	+	+
42	,13		(097) 264-21-67, 776-67-70	+	+	+
43	,3, .5	" "	(04142) 5-05-04	+	+	+
44	,15-106	. .	(06264) 5-93-89	+	+	+
45	,7		(050) 526-06-68	+	+	+
46	,44, .1		(05366) 39-192	+	+	-
47	,42		(056) 401-33-56, 404-00-80, 474-61-03	+	+	+
48	,9		(056) 4092302 03	+	+	+
49	,64/7		(0564) 40-07-79	+	+	+
50	,73	" "	(056) 440-07-64	+	+	+
51	,81		(050) 214-91-73; (066) 017-02-03	+	+	+
52	,49	-	(0642) 505-783	+	+	+
53	,50		(0642)50-57-83	+	+	+

54	,96		(0642) 494-217, 33-11-86	+	+	+
55	,1	-	(0332)290752	+	+	+
56	,15		(032) 244-53-44	+	+	+
57	,35	" "	(032) 2973631	+	+	+
58	,2		(032) 247-14-99	+	+	+
59	,116	" "	(032) 245-80-52	+	+	-
60	,28		(032) 239-51-52 (032) 239-55-77,295-50-28, 295-50-29	+	+	+
61	,9	" "	032-267-63-26	+	+	-
62	242		(062)322-55-50	+	+	+
63	,2	-	04337-64847;0432-468213	+	+	+
64	,24/1		(099) 262-11-18	+	+	+
65	,46		(03131)37-337, 37-336	+	+	-
66	,50, 32/18		(0629) 41-06-50	+	+	+
67	,227	" "	(0629) 473-000	+	+	+
68	,33,	" "	(0512) 580-555	+	+	+
69	,49	" "	0512-58-21-80	+	+	+

70	' ,2		(0512) 58-06-47	+	+	+
71	' ,62	-	(05662) 22-488, (097) 402-71-95	+	+	-
72	' ,97, .2	" ' - "	(05662) 4-15-03	+	+	-
73	' 38		(055) 497-26-17	+	+	-
74	' ,38	" "	(041)4152010	+	+	-
75	' 66 () 2		048-7317704; 7317703;	+	+	+
76	' 90		(048) 700 17 37	+	+	+
77	' ,55	" "	(048) 715-10- 25, (0482) 39- 06-18	+	+	+
78	' ,67	" "	8(05632) 6-15- 54, (05632) 6- 23-42	+	+	-
79	' 26		050-013-72-17, 0532-509889	+	+	+
80	' 14		(0532) 69-42-62	+	+	+
81	' 21	-	(0532) 69-09-46 (093)562-81-25	+	+	+
82	' 66	-	(0532)615-621	+	+	+
83	' ,371	-	(04637)53-982 (093)753-38-28	+	+	+
84	' ,101/1		(046) 3738595	+	+	+
85	' ,12	-	(0362) 26-67- 53,26-65-85	+	+	-

86	' ,26		(0692) 55-56- 43, 45-36-99	+	+	+
87	' ,72	-	(0652)-69-07-78	+	+	+
88	' 17/1	" - "	(0652) 522-771	+	+	+
89	' ,32	-	(04733)-46-182	+	+	-
90	15 (' ')		(06444)40289	+	+	+
91	' 171 /10	-	(245) 53-136	+	+	+
92	' ,19		(0542) 705-296	+	+	-
93	' ,17	SLT- Service	(0542) 78-10-13	+	+	+
94	' ,2	" "	(0352) 26-30- 13, 23-17-97	+	+	-
95	' 1/24	" - "	(047) 44-46- 614,(047) 44- 46-134	+	+	+
96	' ,101		(0312) 661-297	+	+	+
97	' 12		(057) 717-13- 39, 702-16-20	+	+	+
98	' ,3	-	(057) 734-97- 24, 712-51-81	+	+	-
99	18 (' - 42)	" "	(096) 595-37-46	+	+	+
100	' 1		(03142) 42-258	+	+	+
101	' 5	-	(0552) 29-60-42	+	+	+
102	' ,28		(0552) 43-40-33	+	+	+
103	' ,35		(0552) 420-235	-	-	+

104	, 18		(0382)78-37-55, 78-37-73	+	+	+
105	, 10/1	-	(0382) 723-241, 723-240	+	+	+
106	, 63		097-549-20-36	+	+	+
107	, 7, .301	-	0472-633-728	+	+	+
108	, 71	-	(0472) 435-389	+	+	+
109	146, .102	" - "	(0472) 563-478, 500-354, (096) 505-63-63	+	+	+
110	, .77- , 1		(0462) 601585	+	+	+
111	, 6		(0462) 724872,724949	+	+	+
112	, 105 ()		(0372) 55-48- 69,90-13-11	+	+	+
113	, 265		(0372) 58-43-01	+	+	+
114	, 3	" - "	(050) 373-73-71	+	+	+
115	, 5	(-)	(050) 324-43-01	+	+	-

GB

WARRANTY COUPON

**When purchasing the product,
please require its checking before you;**

BE SURE

**that the goods sold to you, are functional and complete
and that the warranty coupon is filled in correctly.**

This warranty coupon confirms the absence of any defects in the product you purchased and provides for free of charge repair of the product failed through the fault of the manufacturer throughout the period of warranty service and free of charge repair.

Failing the presentation of this coupon, in case of its improper filling in, infringement of factory seals (if any), and also in cases indicated in the warranty obligations, the claims are not accepted, and no warranty service and free of charge repair is made!

The warranty coupon is valid only in the original copy with the stamp of trading organization, signature of the seller, date of sale and signature of the buyer.

CZ

ZÁRU NÍ LIST

**P i koupi výrobku
žádejte o jeho vyzkoušení ve Vaší p ítomnosti,
P ESV D TE SE,**

**že Vám prodaný výrobek je dob e fungující a kompletní
a že záru ní list je vypln n správn .**

Tento záru ní list potvrzuje, že na Vámi koupeném výrobku nejsou žádné vady a zajiš uje bezplatnou opravu nefungujícího p ístroje z viny výrobce, b hem celé záru ní doby.

Bez p edložení tohoto listu, p i jeho nesprávném vypln ní, porušení plomb výrobce (jsou-li na výrobku) a také v p ípadech, které jsou uvedené v záru ním list , nároky se nep íjímají a záru ní oprava se neprovádí!

Záru ní list je platný jenom jako originál s razítkem obchodní organizace, podpisem prodáv á, termínem prodeje a podpisem zákazníka.

RU

Saturn®

WARRANTY COUPON

ZÁRU NÍ LIST

SATURN HOME APPLIANCES S.R.O. KON VOVA 141, 13083
PRAHA 3 – ŽIŽKOV, ĚSKÁ REPUBLIKA, TEL: + 4202/ 67 108 392

Model /

Production number/Výrobní íslo/
/

Date of sell/Termín prodeje/ /

Shop stamp/Razítko obchodu/ /

Seller's signature/Podpis prodava e/ /

Buyer's Signature confirming the acquaintance and consent with conditions of free of charge maintenance service of the product, and absence of the complaints on appearance and color of the product.
Podpis zákazníka, potvrzující seznámení a souhlas s podmínkami bezplatného záru ního servisu výrobku, a také neexistence nárok na vn ěšek a barvu výrobku.



UA

Saturn Model / / Production number / / Name of the Trade Company / / Stamp of the Trade Company / / Client Address/Phone # / / Date of Receiving / / Defect / / Signature, Stamp / / , / COUPON 1	Saturn Model / / Production number / / Name of the Trade Company / / Stamp of the Trade Company / / Client Address/Phone # / / Date of Receiving / / Defect / / Signature, Stamp / / , / COUPON 2	Saturn Model / / Production number / / Name of the Trade Company / / Stamp of the Trade Company / / Client Address/Phone # / / Date of Receiving / / Defect / / Signature, Stamp / / , / COUPON 3
---	---	---