

User's Guide

Samsung Multifunction *Xpress*

C48x series

C48xW series

C48xFN series

C48xFW series

BASIC

This guide provides information concerning the installation, basic operation and troubleshooting on windows.

ADVANCED

This guide provides information about the installation, advanced configuration, operation and troubleshooting on various OS environments.

Some features may not be available depending on models or countries.



1. Introduction

| | |
|-------------------------------|----|
| Key benefits | 5 |
| Features by model | 7 |
| Useful to know | 12 |
| About this user's guide | 13 |
| Safety information | 14 |
| Machine overview | 20 |
| Control panel overview | 24 |
| Turning on the machine | 29 |
| Installing the driver locally | 30 |
| Reinstalling the driver | 32 |



2. Menu Overview and Basic Setup

| | |
|--------------------------|----|
| Menu overview | 34 |
| Machine's basic settings | 42 |
| Media and tray | 44 |
| Basic printing | 59 |
| Basic copying | 65 |
| Basic scanning | 69 |
| Basic faxing | 71 |
| Using USB memory device | 75 |



3. Maintenance

| | |
|--|-----|
| Ordering supplies and accessories | 81 |
| Available supplies | 82 |
| Available maintenance parts | 84 |
| Storing the toner cartridge | 85 |
| Redistributing toner | 87 |
| Replacing the toner cartridge | 90 |
| Replacing the imaging unit | 92 |
| Replacing the waste toner container | 95 |
| Monitoring the supplies life | 98 |
| Setting the toner low alert | 99 |
| Cleaning the machine | 100 |
| Tips for moving & storing your machine | 105 |



4. Troubleshooting

| | |
|--------------------------------|-----|
| Tips for avoiding paper jams | 107 |
| Clearing paper jams | 108 |
| Understanding the status LED | 115 |
| Understanding display messages | 117 |



5. Appendix

| | |
|-------------------------------|------------|
| Specifications | 125 |
| Regulatory information | 133 |
| Copyright | 146 |



1. Introduction

This chapter provides information you need to know before using the machine.

- **Key benefits** 5
- **Features by model** 7
- **Useful to know** 12
- **About this user's guide** 13
- **Safety information** 14
- **Machine overview** 20
- **Control panel overview** 24
- **Turning on the machine** 28
- **Installing the driver locally** 29
- **Reinstalling the driver** 31



Key benefits

Environmentally friendly



- To save toner and paper, this machine supports Eco feature (see "Eco printing" on page 58).
- To save paper, you can print multiple pages on one single sheet of paper (see "Using advanced print features" on page 231).
- To save paper, you can print on both sides of the paper (double-sided printing) (Manual) (see "Using advanced print features" on page 231).
- To save electricity, this machine automatically conserves electricity by substantially reducing power consumption when not in use.
- We recommend using recycled paper for saving energy.

Fast high resolution printing



- You can print in a full range of colors using cyan, magenta, yellow, and black.
- You can print with a resolution of up to 2,400 x 600 dpi effective output (600 x 600 x 2 bit).
- Fast, on-demand printing.

Convenience



- Simply touch your cell phone on the NFC tag on your printer and get the print job done (see "Using the NFC feature" on page 187).
- You can print on the go from your smartphone or computer using Samsung Cloud Print apps (see "Samsung Cloud Print" on page 198).
- You can print on the go from your smartphone or computer using Google Cloud Print enabled apps (see "Google Cloud Print™" on page 201).
- Easy Capture Manager allows you to easily edit and print whatever you captured using the Print Screen key on the keyboard (see "Easy Capture Manager" on page 259).
- Samsung Easy Printer Manager and Printing Status is a program that monitors and informs you of the machine's status and allows you to customize the machine's settings (see "Using Samsung Easy Printer Manager" on page 268 or "Using Samsung Printer Status" on page 271).
- Samsung Easy Document Creator is an application to help users compile and share large documents or other scanned or faxed information digitally. (see "Using Samsung Easy Document Creator" on page 270).
- Smart Update allows you to check for the latest software and install the latest version during the printer driver installation process. This is available only for Windows.
- If you have Internet access, you can get help, support application, machine drivers, manuals, and order information from the Samsung website, www.samsung.com > find your product > Support or Downloads.

Key benefits

Wide range of functionality and application support



- Supports various paper sizes (see "Print media specifications" on page 127).
- Print watermark: You can customize your documents with words, such as "**CONFIDENTIAL**" (see "Using advanced print features" on page 231).
- Print posters: The text and pictures of each page of your document are magnified and printed across the multiple sheets of paper and can then be taped together to form a poster (see "Using advanced print features" on page 231).
- You can print in various operating systems (see "System requirements" on page 130).
- Your machine is equipped with a USB interface and/or a network interface.

Supports various wireless network setting method



- Using the WPS (Wi-Fi Protected Setup™) button
 - You can easily connect to a wireless network using the WPS button on the machine and the access point (a wireless router).

- Using the USB cable or a network cable
 - You can connect and set various wireless network settings using a USB cable or a network cable.
- Using the Wi-Fi Direct
 - You can conveniently print from your mobile device using the Wi-Fi or Wi-Fi Direct feature.



See "Introducing wireless set up methods" on page 168.

Features by model

Some features and optional goods may not be available depending on model or country.

Operating System

| Operating System | C48x series | C48xW series | C48xFN series | C48xFW series |
|------------------|-------------|--------------|---------------|---------------|
| Windows | • | • | • | • |
| Mac | • | • | • | • |
| Linux | • | • | • | • |

(•: Supported, Blank: Not supported)

Features by model

Software

You can install the printer driver and software when you insert the software CD into your CD-ROM drive.

For Windows, select the printer driver and software in the **Select Software to Install** window.

| Software | | C48x series | C48xW series | C48xFN series | C48xFW series |
|--|---------------------|----------------|--------------|---------------|---------------|
| SPL printer driver | | • | • | • | • |
| PCL printer driver | | • | • | • | • |
| PS printer driver ^a | | • | • | • | • |
| XPS printer driver ^a | | • | • | • | • |
| Samsung Easy Printer Manager | Scan to PC settings | • ^b | • | • | • |
| | Fax to PC settings | | | • | • |
| | Advanced Setting | • | • | • | • |
| Samsung Easy Document Creator ^a | | • | • | • | • |
| Samsung Easy Color Manager | | • | • | • | • |
| Samsung Printer Status | | • | • | • | • |
| Samsung Printer Center | | • | • | • | • |
| SyncThru™ Web Service | | | • | • | • |
| Samsung Eco Driver Pack ^c | | • | • | • | • |

Features by model

| Software | | C48x series | C48xW series | C48xFN series | C48xFW series |
|--|-------------------------------|-------------|--------------|---------------|---------------|
| Samsung Stylish Driver Pack^d | | ● | ● | ● | ● |
| SyncThru™ Web Service | | ● | ● | ● | ● |
| Fax | Samsung Network PC Fax | | | ● | ● |
| Scan | Twain scan driver | ● | ● | ● | ● |
| | WIA scan driver | ● | ● | ● | ● |

- Download the software from the Samsung website and install it: (<http://www.samsung.com> > find your product > Support or Downloads). Before installing, check whether your computer's OS support the software.
- Some models do not support this feature. If this feature doesn't appear in the menu of Samsung Easy Printer Manager, then this feature is not available on your model.
- To use the Easy Eco Driver features, the Eco Driver Pack must be installed.
- The printer driver includes a user interface that is optimized for touchscreens. To use this UI, click **Samsung Printer Center** > **Device Options** and then select **Stylish User Interface** (see "Using Samsung Printer Center" on page 262).

(●: Supported, Blank: Not supported)

Features by model

Variety feature

| Features | C48x series | C48xW series | C48xFN series | C48xFW series |
|---|-------------|--------------|---------------|---------------|
| Hi-Speed USB 2.0 | • | • | • | • |
| Network Interface Ethernet 10/100 Base TX wired LAN | | • | • | • |
| Network Interface 802.11b/g/n wireless LAN ^a | | • | | • |
| NFC (Near Field Communication) | | • | | • |
| Mopria™ | | • | • | • |
| Samsung Cloud Print | | • | • | • |
| Google Cloud Print™ | | • | • | • |
| AirPrint | | • | • | • |
| Eco printing (Control panel) | | • | • | • |
| Duplex (2-sided) printing (Manual) ^b | • | • | • | • |
| USB memory interface | | • | • | • |
| Automatic Document Feeder (ADF) | | | • | • |

a. Depending on your country, wireless LAN card may not be available. For some countries, only 802.11 b/g can be applied. Contact your local Samsung dealer or the retailer where you bought your machine.

b. Windows only.

(●: Supported, Blank: Not supported)

Features by model

| Features | | C48x series | C48xW series | C48xFN series | C48xFW series |
|----------|---------------------------------------|-------------|--------------|---------------|---------------|
| Fax | Multi-send | | | ● | ● |
| | Delay send | | | ● | ● |
| | Secure receive | | | ● | ● |
| | Send/ Receive forward - fax/ Email | | | ● | ● |
| Scan | Scan to PC | | ● | ● | ● |
| Copy | ID card copying | ● | ● | ● | ● |
| | Reduced or enlarged copying | ● | ● | ● | ● |
| | Collation | ● | ● | ● | ● |
| | 2-up/4-up | ● | ● | ● | ● |
| | Adjust background | ● | ● | ● | ● |

(●: Supported, Blank: Not supported)

Useful to know



The machine does not print.

- Open the print queue list and remove the document from the list (see "Canceling a print job" on page 55).
- Remove the driver and install it again (see "Installing the driver locally" on page 29).
- Select your machine as your default machine in your Windows (see "Setting your machine as a default machine" on page 230).



Where can I purchase accessories or supplies?

- Inquire at a Samsung distributor or your retailer.
- Visit www.samsung.com/supplies. Select your country/region to view product service information.



The status LED flashes or remains constantly on.

- Turn the product off and on again.
- Check the meanings of LED indications in this manual and troubleshoot accordingly (see "Understanding the status LED" on page 115).



A paper jam has occurred.

- Open and close the cover (see "Front view" on page 21).
- Check the instructions on removing jammed paper in this manual and troubleshoot accordingly (see "Clearing paper jams" on page 108).



Printouts are blurry.

- The toner level might be low or uneven. Shake the toner cartridge (see "Redistributing toner" on page 85).
- Try a different print resolution setting (see "Opening printing preferences" on page 56).
- Replace the toner cartridge (see "Replacing the toner cartridge" on page 87).



Where can I download the machine's driver?

- You can get help, support application, machine drivers, manuals, and order information from the Samsung website, www.samsung.com > find your product > Support or Downloads.

About this user's guide

This user's guide provides information for your basic understanding of the machine as well as detailed steps to explain machine usage.



- Do not discard this manual, and keep it for future reference.
- Read the safety information before using the machine.
- If you have a problem using the machine, refer to the troubleshooting chapter.
- Terms used in this user's guide are explained in the glossary chapter.
- All illustrations in this user's guide may differ from your machine depending on its options or model you purchased.
- The screenshots in this administrator's guide may differ from your machine depending on the machine's firmware/driver version.
- The procedures in this user's guide are mainly based on Windows 7.

Conventions

Some terms in this guide are used interchangeably, as below:

- Document is synonymous with original.
- Paper is synonymous with media, or print media.
- Machine refers to printer or MFP.

General icons



| Icon | Text | Description |
|---|----------------|--|
|  | Warning | Used to alert users to the possibility of personal injury. |
|  | Caution | Gives users information to protect the machine from possible mechanical damage or malfunction. |
|  | Note | Provides additional information or detailed specification of the machine function and feature. |

Safety information

These warnings and precautions are included to prevent injury to you and others, and to prevent any potential damage to your machine. Be sure to read and understand all of these instructions before using the machine. After reading this section, keep it in a safe place for future reference.

Important safety symbols

Explanation of all icons and signs used in this chapter

| | | |
|---|----------------|--|
|  | Warning | Hazards or unsafe practices that may result in severe personal injury or death. |
|  | Caution | Hazards or unsafe practices that may result in minor personal injury or property damage. |
|  | | Do not attempt. |

Operating environment

Warning



Do not use if the power cord is damaged or if the electrical outlet is not grounded.

This could result in electric shock or fire.



Do not place anything on top of the machine (water, small metal or heavy objects, candles, lit cigarettes, etc.).

This could result in electric shock or fire.

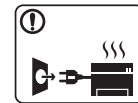

- If the machine gets overheated, it releases smoke, makes strange noises, or generates an odd odor, immediately turn off the power switch and unplug the machine.

- The user should be able to access the power outlet in case of emergencies that might require the user to pull the plug out.

This could result in electric shock or fire.



Do not bend, or place heavy objects on the power cord.

Stepping on or allowing the power cord to be crushed by a heavy object could result in electric shock or fire.







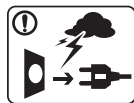

Do not remove the plug by pulling on the cord; do not handle the plug with wet hands.

This could result in electric shock or fire.







Safety information

Caution

| | |
|--|--|
|  | <p>During an electrical storm or for a period of non-operation, remove the power plug from the electrical outlet.</p> <p>This could result in electric shock or fire.</p> |
|  | <p>Be careful, the paper output area is hot.</p> <p>Burns could occur.</p> |
|  | <p>If the machine has been dropped, or if the cabinet appears damaged, unplug the machine from all interface connections and request assistance from qualified service personnel.</p> <p>Otherwise, this could result in electric shock or fire.</p> |
|  | <p>If the machine does not operate properly after these instructions have been followed, unplug the machine from all interface connections and request assistance from qualified service personnel.</p> <p>Otherwise, this could result in electric shock or fire.</p> |
|  | <p>If the plug does not easily enter the electrical outlet, do not attempt to force it in.</p> <p>Call an electrician to change the electrical outlet, or this could result in electric shock.</p> |
|  | <p>Do not allow pets to chew on the AC power, telephone or PC interface cords.</p> <p>This could result in electric shock or fire and/or injury to your pet.</p> |

Operating method

Caution

| | |
|---|--|
|  | <p>Do not forcefully pull the paper out during printing.</p> <p>It can cause damage to the machine.</p> |
|  | <p>Be careful not to put your hand between the machine and paper tray.</p> <p>You may get injured.</p> |
|  | <p>Be care when replacing paper or removing jammed paper.</p> <p>New paper has sharp edges and can cause painful cuts.</p> |
|  | <p>When printing large quantities, the bottom part of the paper output area may get hot. Do not allow children to touch.</p> <p>Burns can occur.</p> |
|  | <p>When removing jammed paper, do not use tweezers or sharp metal objects.</p> <p>It can damage the machine.</p> |
|  | <p>Do not allow too many papers to stack up in the paper output tray.</p> <p>It can damage the machine.</p> |

Safety information



Do not block or push objects into the ventilation opening.
This could result in elevated component temperatures which can cause damage or fire.



Use of controls or adjustments or performance of procedures other than those specified herein may result in hazardous radiation exposure.



This machine's power reception device is the power cord.
To switch off the power supply, remove the power cord from the electrical outlet.

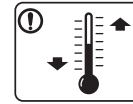

Place the machine in the environment where it meets the operating temperature and humidity specification.

Do not use the machine when it is below freezing temperature or has recently been moved from a location below freezing temperature. Doing so may damage the machine. Only operate the machine when the internal temperature of the machine is within the operating temperature and humidity specifications.

Otherwise, quality problems can occur and cause damage to the machine.

See "General specifications" on page 125.

Installation / Moving

Warning



Do not place the machine in an area with dust, humidity, or water leaks.

This could result in electric shock or fire.

Caution



Before moving the machine, turn the power off and disconnect all cords. The information below are only suggestions based on the units weight. If you have a medical condition that prevents you from lifting, do not lift the machine. Ask for help, and always use the appropriate amount of people to lift the device safely.

Then lift the machine:

- If the machine weighs under 20 kg (44.09 lbs), lift with 1 person.
- If the machine weighs 20 kg (44.09 lbs) - 40kg (88.18 lbs), lift with 2 people.
- If the machine weighs more than 40 kg (88.18 lbs), lift with 4 or more people.

The machine could fall, causing injury or machine damage.

Safety information

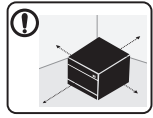

Choose a flat surface with enough space for ventilation to place the machine. Also consider the space required to open the cover and trays.

The place should be well-ventilated and be far from direct light, heat, and humidity.



When using the machine for a long period of time or printing a large number of pages in a non-ventilated space, it could pollute the air and be harmful to your health. Place the machine in a well-ventilated space or open a window to circulate the air periodically.



Do not place the machine on an unstable surface.
The machine could fall, causing injury or machine damage.



Use only No.26 AWG^a or larger, telephone line cord, if necessary.
Otherwise, it can cause damage to the machine.



Make sure you plug the power cord into a grounded electrical outlet.
Otherwise, this could result in electric shock or fire.



Use the power cord supplied with your machine for safe operation. If you are using a cord which is longer than 2 meters (6 feet) with a 110V machine, then the gauge should be 16 AWG or larger.
Otherwise, it can cause damage to the machine, and could result in electric shock or fire.



Do not put a cover over the machine or place it in an airtight location, such as a closet.
If the machine is not well-ventilated, this could result in fire.



Do not overload wall outlets and extension cords.
This can diminish performance, and could result in electric shock or fire.



The machine should be connected to the power level which is specified on the label.
If you are unsure and want to check the power level you are using, contact the electrical utility company.

a. AWG: American Wire Gauge

Maintenance / Checking







Caution



Unplug this product from the wall outlet before cleaning the inside of the machine. Do not clean the machine with benzene, paint thinner or alcohol; do not spray water directly into the machine.





This could result in electric shock or fire.

Safety information

| | |
|--|---|
|  | <p>When you are working inside the machine replacing supplies or cleaning the inside, do not operate the machine.</p> <p>You could get injured.</p> |
|  | <p>Keep cleaning supplies away from children.</p> <p>Children could get hurt.</p> |
|  | <p>Do not disassemble, repair or rebuild the machine by yourself.</p> <p>It can damage the machine. Call a certified technician when the machine needs repairing.</p> |
|  | <p>To clean and operate the machine, strictly follow the user's guide provided with the machine.</p> <p>Otherwise, you could damage the machine.</p> |
|  | <p>Keep the power cable and the contact surface of the plug clean from dust or water.</p> <p>Otherwise, this could result in electric shock or fire.</p> |
|  | <ul style="list-style-type: none">• Do not remove any covers or guards that are fastened with screws.• Fuser units should only be repaired by a certified service technician. Repair by non-certified technicians could result in fire or electric shock.• The machine should only be repaired by a Samsung service technician. |

Supply usage

Caution

| | |
|---|---|
|  | <p>Do not disassemble the toner cartridge.</p> <p>Toner dust can be dangerous if inhaled or ingested.</p> |
|  | <p>Do not burn any of the supplies such as toner cartridge or fuser unit.</p> <p>This could cause an explosion or uncontrollable fire.</p> |
|  | <p>When storing supplies such as toner cartridges, keep them away from children.</p> <p>Toner dust can be dangerous if inhaled or ingested.</p> |
|  | <p>For supplies that contain toner dust (toner cartridge, waste toner bottle, imaging unit, etc.) follow the instructions below.</p> <ul style="list-style-type: none">• When disposing of the supplies, follow the instructions for disposal. Refer to the reseller for disposal instructions.• Do not wash the supplies.• For a waste toner bottle, do not reuse it after emptying the bottle. <p>If you do not follow the instructions above, it may cause machine malfunction and environmental pollution. The warranty does not cover damages caused by a user's carelessness.</p> |

Safety information



Using recycled supplies, such as toner, can cause damage to the machine.

In case of damage due to the use of recycled supplies, a service fee will be charged.



When toner gets on your clothing, do not use hot water to wash it.

Hot water sets toner into fabric. Use cold water.



When changing the toner cartridge or removing jammed paper, be careful not to let toner dust touch your body or clothes.

Toner dust can be dangerous if inhaled or ingested.

Machine overview

Components

The actual component may differ from the illustration below. Some components may change depending on the configuration.

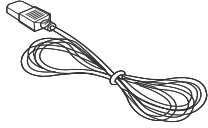
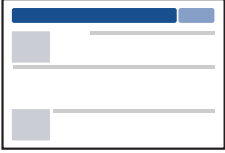
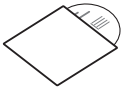
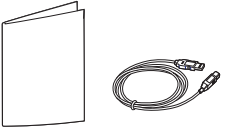
| | |
|---|---|
|  |  |
| Power cord | Quick installation guide |
|  |  |
| Software CD ^a | Misc. accessories ^b |

a. The software CD contains the print drivers, user's guide, and software applications.

b. Miscellaneous accessories included with your machine may vary by country of purchase and specific model.

Machine overview

Front view



- This illustration may differ from your machine depending on your model. There are various types of machine.
- Some features and optional goods may not be available depending on model or country (see "Features by model" on page 7).

C48x/C48xW series

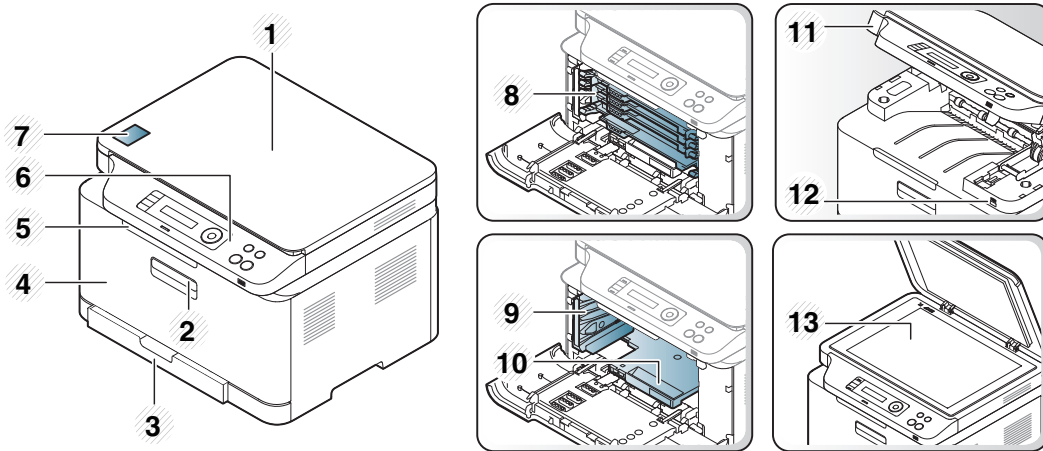

| | | | |
|---|--------------|----|-----------------------|
| 1 | Scanner lid | 8 | Toner cartridges |
| 2 | Front handle | 9 | Waste toner container |
| 3 | Tray | 10 | Imaging unit |

| | | | |
|---|----------------------|----|------------------------------|
| 4 | Front door | 11 | Scan unit ^{a b} |
| 5 | Output support | 12 | USB memory port ^c |
| 6 | Control panel | 13 | Scanner glass |
| 7 | NFC tag ^c | | |

a. Close the scanner lid before opening the scan unit.

b. Be careful not to pinch your fingers.

c. C48xW series only.

Machine overview

C48xFN/C48xFW series

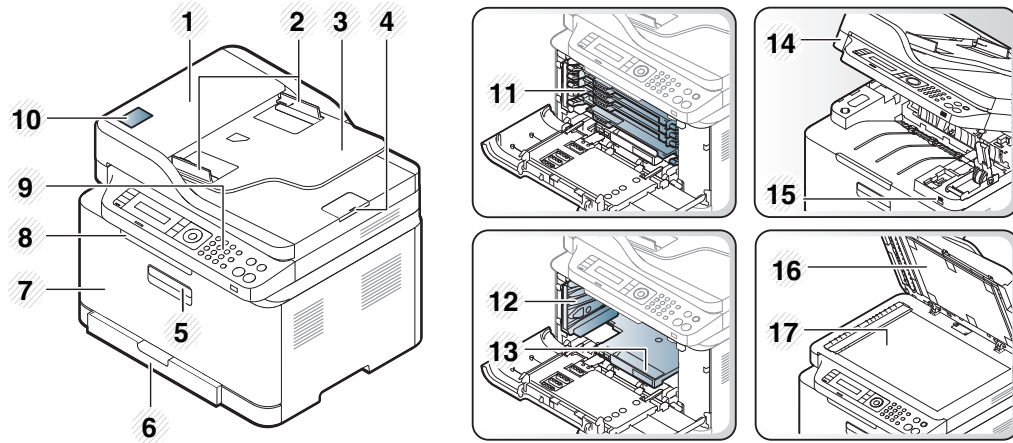

- a. C48xFW series only.
- b. Close the scanner lid before opening the scan unit.
- c. Be careful not to pinch your fingers.

| | | | |
|---|--------------------------------|----|--------------------------|
| 1 | Document feeder cover | 10 | NFC tag ^a |
| 2 | Document feeder width guide | 11 | Toner cartridges |
| 3 | Document feeder input tray | 12 | Waste toner container |
| 4 | Document feeder output support | 13 | Imaging unit |
| 5 | Front handle | 14 | Scan unit ^{b c} |
| 6 | Tray | 15 | USB memory port |
| 7 | Front cover | 16 | Scanner lid |
| 8 | Output support | 17 | Scanner glass |
| 9 | Control panel | | |

Machine overview

Rear view



- This illustration may differ from your machine depending on your model. There are various types of machine.
- Some features and optional goods may not be available depending on model or country (see "Features by model" on page 7).

C48x/C48xW series

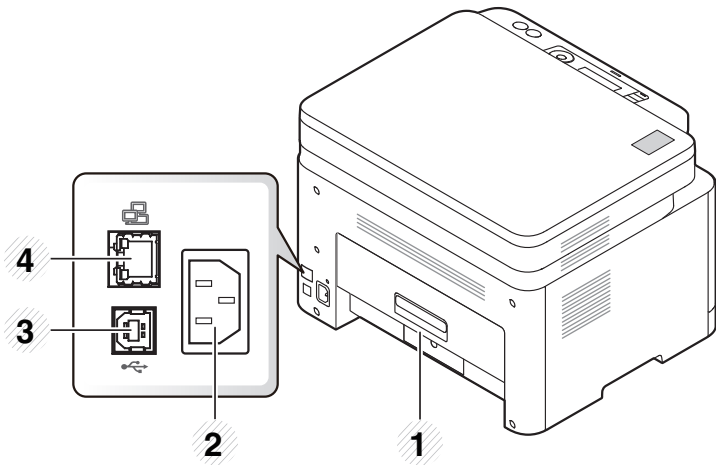

| | | | |
|---|------------------|---|---------------------------|
| 1 | Rear cover | 3 | USB port |
| 2 | Power receptacle | 4 | Network port ^a |

a. C48xW series only.

C48xFN/C48xFW series

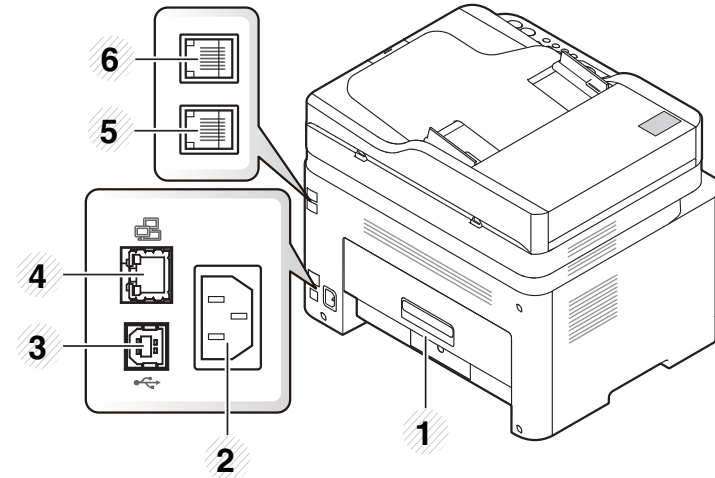

| | | | |
|---|------------------|---|--|
| 1 | Rear cover | 4 | Network port |
| 2 | Power receptacle | 5 | Telephone line socket (LINE) |
| 3 | USB port | 6 | Extension telephone socket (EXT.) |

Control panel overview





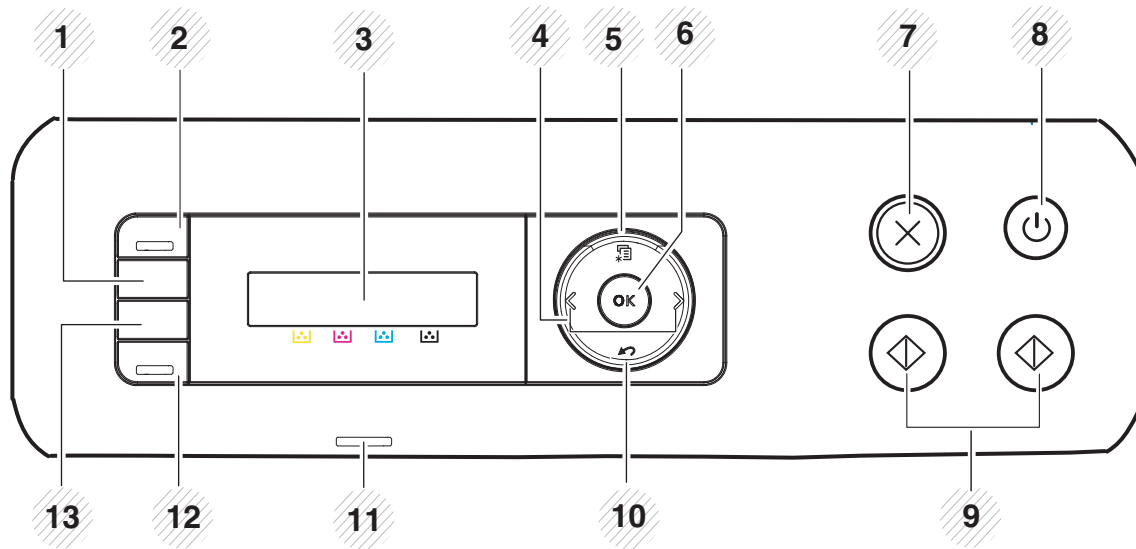

- This control panel may differ from your machine depending on its model. There are various types of control panels.
- Some features and optional goods may not be available depending on model or country (see "Features by model" on page 7).

C48x/C48xW series



| | | |
|---|----------------------------|---|
| 1 | WPS^a | Configures the wireless network connection easily without a computer (see "Using the WPS Settings menu" on page 169). |
| 2 | Scan to^a | Switches between scan and copy mode. The Scan to LED turns on scan mode and turns off on copy mode. |
| 3 | Display screen | Shows the current status and displays prompts during an operation. |
| 4 | Arrows | Scrolls through the options available in the selected menu and increases or decreases values. |

Control panel overview

| | | | |
|----|--|---|--|
| 5 | Menu |  | Opens Menu mode and scrolls through the available menus (see "Menu overview" on page 34). |
| 6 | OK | | Confirms the selection on the screen. |
| 7 | Stop/Clear |  | Stops an operations at any time. |
| 8 | Power/Wake Up |  | Turns the power on or off, or wakes up the machine from the power save mode. If you need to turn the machine off, press this button for more than three seconds when the machine is in ready mode. |
| 9 | Start |  | Starts a job. |
| 10 | Back |  | Sends you back to the upper menu level. |
| 11 | Status/Wireless LED^a | | Indicates the status of your machine (see "Understanding the status LED" on page 115). |
| | Status LED^b | | |
| 12 | Eco^a | | Turn into eco mode to reduce toner consumption and paper usage when pc-printing and copying only (see "Eco printing" on page 58). |
| 13 | Direct USB^a | | Allows you to directly print files stored on a USB memory device when it is inserted into the USB port on the front of your machine. |

a. C48xW series only.

b. C48x series only.





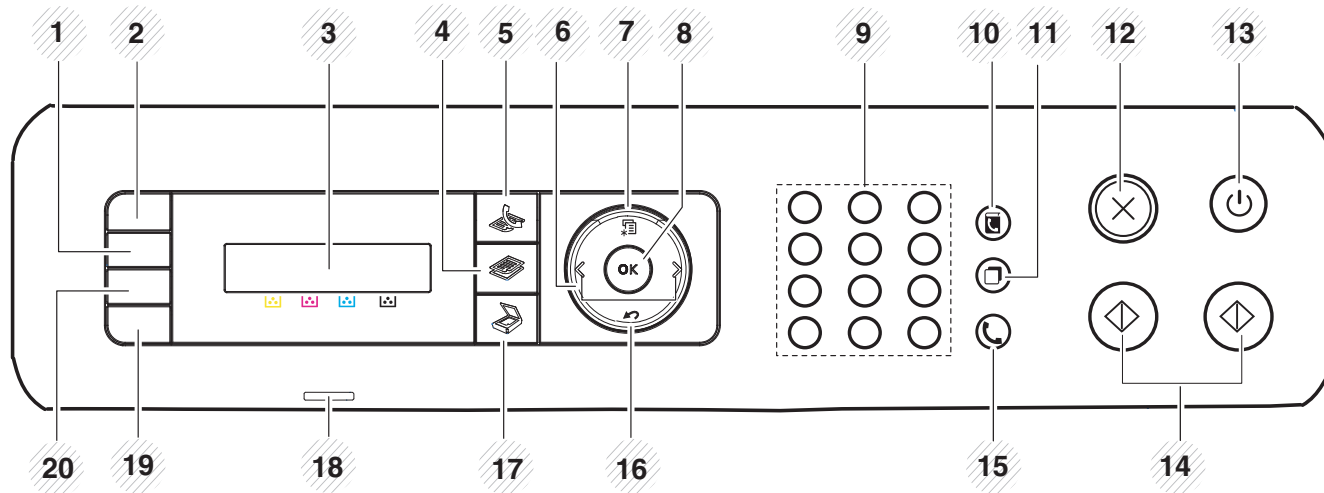



Control panel overview

C48xFN/C48xFW series



| | | |
|---|------------------------|---|
| 1 | WPS^a | Configures the wireless network connection easily without a computer (see "Using the WPS Settings menu" on page 169). |
| 2 | ID Copy | Allows you to copy both sides of an ID card like a driver's license on a single side of paper (see "ID card copying" on page 62). |
| 3 | Display screen | Shows the current status and displays prompts during an operation. |
| 4 | Copy | Switches to Copy mode. |
| 5 | Fax | Switches to Fax mode. |
| 6 | Arrows | Scrolls through the options available in the selected menu and increases or decreases values. |
| 7 | Menu | Opens Menu mode and scrolls through the available menus (see "Menu overview" on page 34). |
| 8 | OK | Confirms the selection on the screen. |

Control panel overview

| | | | |
|----|--|---|--|
| 9 | Numeric keypad | | Dials a number or enters alphanumeric characters (see "Keypad letters and numbers" on page 226). |
| 10 | Address Book |  | Allows you to store frequently used fax numbers or search for stored fax numbers (see "Setting up the fax address book" on page 227). |
| 11 | Redial/Pause |  | Redials the recently sent fax number or received caller ID in ready mode, or inserts a pause(-) into a fax number in edit mode (see "Redialing the fax number" on page 249). |
| 12 | Stop/Clear |  | Stops an operations at any time. |
| 13 | Power/Wake Up |  | Turns the power on or off, or wakes up the machine from the power save mode. If you need to turn the machine off, press this button for more than three seconds when the machine is in ready mode. |
| 14 | Start |  | Starts a job. |
| 15 | On Hook Dial |  | When you press this button, you can hear a dial tone. Then enter a fax number. It is similar to making a call using speaker phone (see "Receiving manually in Tel mode" on page 254). |
| 16 | Back |  | Sends you back to the upper menu level. |
| 17 | Scan |  | Switches to Scan mode. |
| 18 | Status/Wireless LED^a | | Indicates the status of your machine (see "Understanding the status LED" on page 115). |
| | Status LED^b | | |
| 19 | Eco | | Turn into eco mode to reduce toner consumption and paper usage when pc-printing and copying only (see "Eco printing" on page 58). |
| 20 | Direct USB | | Allows you to directly print files stored on a USB memory device when it is inserted into the USB port on the front of your machine. |

a. C48xFW series only.

b. C48xFN series only.

Turning on the machine



Keep in mind that you should use the power cord supplied with the machine. Otherwise, it can cause damage or fire to the machine.

1 Connect the machine to the electricity supply first.

Turn the switch on if the machine has a power switch.

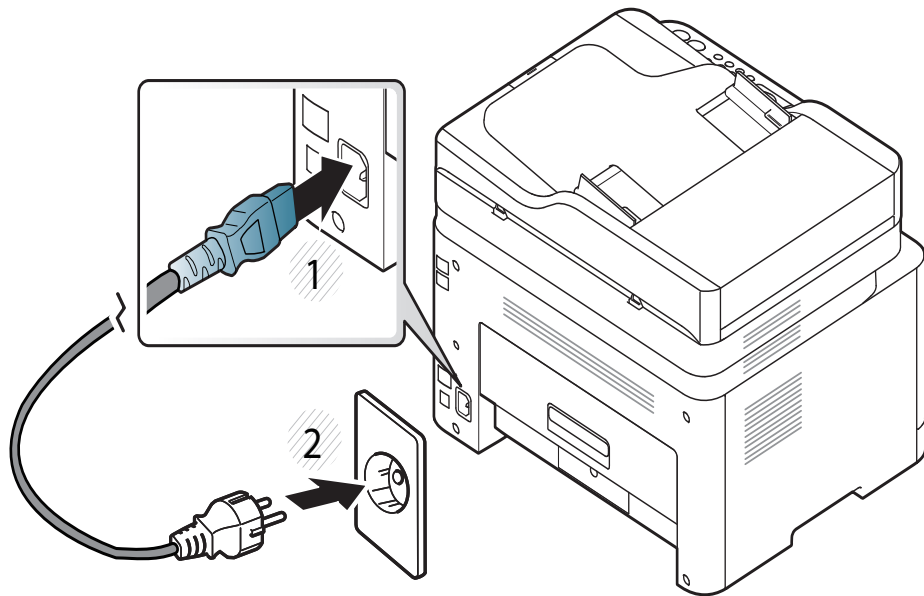

Illustrations on this user's guide may differ from your machine depending on its options or models. Check your machine type (see "Front view" on page 21).

2

Power is turned on automatically.

For C48x/C48xW series, press  (**Power/Wake Up**) button on the control panel.



If you want to turn the power off, press and hold  (**Power/Wake Up**) button for about 3 seconds.

Installing the driver locally

A locally connected machine is a machine directly attached to your computer using a USB cable. If your machine is attached to a network, skip the following steps below and go on to installing a network connected machine's driver (see "Installing driver over the network" on page 160).



- If you are a Mac or Linux operating systems user, refer to the "Installation for Mac" on page 151 or "Installation for Linux" on page 153.
- The installation window in this User's Guide may differ depending on the machine and interface in use.
- Only use a USB cable no longer than 3 meters (118 inches).

Windows

- 1 Make sure that the machine is connected to your computer and powered on.
- 2 Insert the supplied software CD into your CD-ROM drive.
If the installation window does not appear, click **Start > All programs > Accessories > Run**.
X:\Setup.exe replacing "X" with the letter, which represents your CD-ROM drive and click **OK**.
 - For Windows 8,
If the installation window does not appear, from **Charms**, select **Search > Apps** and search for **Run**. Type in X:\Setup.exe, replacing "X" with the letter that represents your CD-ROM drive and click **OK**.
If "**Tap to choose what happens with this disc.**" pop-up window appears, click the window and select **Run Setup.exe**.
- 3 Review and accept the installation agreements in the installation window. Then, click **Next**.
- 4 Select **USB** on the **Printer Connection Type** screen. Then, click **Next**.
- 5 Follow the instructions in the installation window.

Installing the driver locally



You can select the software applications in the **Select Software to Install** window.

From the Windows 8 Start Screen



- The V4 driver is automatically downloaded from the Windows Update if your computer is connected to the Internet. If not, you can manually download the V4 driver from Samsung website, www.samsung.com > find your product > Support or downloads.
- You can download Samsung Printer Experience app from the **Windows Store**. You need have a Microsoft account to use the Windows **Store**.
 - 1 From **Charms**, select **Search**.
 - 2 Click **Store**.
 - 3 Search and click **Samsung Printer Experience**.
 - 4 Click **Install**.
- If you install the driver using the supplied software CD, V4 driver is not installed. If you want to use the V4 driver in the **Desktop** screen, you can download from the Samsung website, www.samsung.com > find your product > Support or downloads.
- If you want to install Samsung's printer management tools, you need to install them using the supplied software CD.

- 1 Make sure that your computer is connected to the Internet and powered on.
- 2 Make sure that the machine is powered on.
- 3 Connect the computer and the machine with a USB cable.
The driver is automatically installed from the **Windows Update**.

Reinstalling the driver

If the printer driver does not work properly, follow the steps below to reinstall the driver.

Windows

- 1 Make sure that the machine is connected to your computer and powered on.
- 2 From the **Start** menu, select **Programs** or **All Programs > Samsung Printers > Uninstall Samsung Printer Software**.
 - For Windows 8,
 - 1 From Charms, select **Search > Apps**.
 - 2 Search and click **Control Panel**.
 - 3 Click **Programs and Features**.
 - 4 Right-click the driver you want to uninstall and select **Uninstall**.
- 3 Follow the instructions in the installation window.
- 4 Insert the software CD into your CD-ROM drive and install the driver again (see "Installing the driver locally" on page 29).

From the Windows 8 Start Screen

- 1 Make sure that the machine is connected to your computer and powered on.
- 2 Click on the **Uninstall Samsung Printer Software** tile in the **Start** screen.
- 3 Follow the instructions in the window.



- If you cannot find a Samsung Printer Software tile, uninstall from the desktop screen mode.
- If you want to uninstall Samsung's printer management tools, from the **Start** screen, right-click the app > **Uninstall** > right-click the program you want to delete > **Uninstall** and follow the instruction in the window.



2. Menu Overview and Basic Setup

This chapter provides information about the overall menu structure and the basic setup options.

- **Menu overview** 34
- **Machine's basic settings** 38
- **Media and tray** 40
- **Basic printing** 54
- **Basic copying** 60
- **Basic scanning** 64
- **Basic faxing** 65
- **Using USB memory device** 69





Menu overview

The control panel provides access to various menus to set up the machine or use the machine's functions.



- An asterisk (*) appears next to the currently selected menu.
- Some menus may not appear on the display depending on options or models. If so, it is not applicable to your machine.
- Some menu names may differ from your machine depending on its options or the models.
- The menus are described in the Advanced Guide (see "Useful Setting Menus" on page 204).

Accessing the menu

- 1 Select the Copy, Fax, or Scan button on the control panel depending on the feature to be used.
- 2 Select  (**Menu**) until the menu you want appears on the bottom line of the display and press **OK**.
- 3 Press the left/right arrows until the needed menu item appears and press **OK**.
- 4 If the setting item has sub menus, repeat step 3.
- 5 Press **OK** to save the selection.
- 6 Press  (**Stop/Clear**) to return to the ready mode.

Menu overview

| Copy Feature (see "Copy" on page 207) | Copy Setup (see "Copy" on page 207) | Fax Feature ^a (see "Fax" on page 210) | | Fax Setup ^a (see "Fax" on page 210) | |
|--|--|--|---|--|--|
| Original Size Reduce/Enlarge Darkness Normal Dark+1- Dark+5 Light+5- Light+1 Original Type Text Text/Photo Photo Magazine Collation On Off Layout Normal 2-Up 4-Up ID Copy Adjust Bkgd. Off Auto Enhance Lev.1 Enhance Lev.2 Erase Lev.1- Erase Lev.4 | Change Default Original Size Copies Reduce/Enlarge Darkness Original Type Collation | Darkness Light+5- Light+1 Normal Dark+1- Dark+5 Resolution Standard Fine Super Fine Photo Fax Original Size Multi Send Delay Send Send Forward Forward to Fax Fwd. to Email | Rcv. Forward Forward to Fax Forward to PC Fwd. to Email Forward&Print Secure Receive Off On Print Cancel Job | Sending Redial Times Redial Term Prefix Dial ECM Mode Modem Speed Fax Confirm. Image TCR Dial Mode^b Receiving Receive Mode Ring to Answer Stamp Rcv Name Rcv Start Code Auto Reduction Discard Size Junk Fax Setup DRPD Mode^b | Change Default Darkness Resolution Original Size Smart Fax Diag Auto Config. Start Now Initialize Manual TX/RX On Off |

a. C48xFN/C48xFW series only.

b. This option may not be available depending on your country.

Menu overview

| Scan Feature ^a (see "Scan" on page 214) | Scan Setup ^a (see "Scan" on page 214) | Print Setup (see "Print" on page 206) | |
|---|--|---|---|
| USB Feature Original Size Original Type Resolution Color Mode File Format Darkness Email Feature^b Original Size Original Type Resolution Color Mode Darkness Samsung Cloud^b Original Size Original Type Resolution Color Mode Darkness | Change Default USB Default Email Default ^b Samsung Cloud ^b | Orientation Portrait Landscape Copies [1 - 999] Resolution Standard High Resol. Clear Text Off Minimum Medium Maximum Edge Enhance Off Normal Maximum Trapping Off Normal Maximum | Screen Normal Enhanced Detailed Auto CR LF LF+CR SkipBlankPages On Off Emulation Emulation Type Setup |

a. C48xW/C48xFN/C48xFW series only.

b. C48xFN/C48xFW series only.

Menu overview

| System Setup (see "System setup" on page 216) | | | | Network ^a (see "Network setup" on page 222) | |
|--|---------------------------|-----------------------------|----------------------------|---|--------------------------|
| Machine Setup | Paper Setup | Report | Maintenance | TCP/IP (IPv4) | Wi-Fi^e |
| Machine ID ^b | Paper Size | Configuration | CLR Empty Msg ^d | DHCP | Wi-Fi On/Off |
| Fax Number ^b | Paper Type | Demo Page | Supplies Life | BOOTP | Wi-Fi Settings |
| Date & Time ^b | Margin | Network Conf. ^a | Image Mgr. | Static | WPS |
| Clock Mode ^b | Sound/Volume ^b | Supplies Info. | Custom Color | TCP/IP (IPv6) | Wi-Fi Direct |
| Language | Key Sound | Usage Counter | TonerLow Alert | IPv6 Protocol | Wi-Fi Signal |
| Default Mode ^b | Alarm Sound | Fax Received ^b | ImgU.Low Alert | DHCPv6 Config | Wi-Fi Default |
| Power Save | Speaker | Fax Sent ^b | Serial Number | Ethernet | Protocol Mgr. |
| Auto Power Off ^c | Ringer | Scheduled Jobs ^b | | Ethernet Port | HTTP |
| Wakeup Event | | Fax Confirm. ^b | | Ethernet Speed | SCP |
| System Timeout | | Email Sent ^b | | | WINS |
| Job Timeout | | Junk Fax ^b | | | SNMPv1/v2 |
| Altitude Adj. | | PCL Font | | | UPnP(SSDP) |
| Humidity | | PS Font | | | mDNS |
| Auto Continue | | Address Book ^b | | | SetIP |
| Paper Substit. | | | | | SLP |
| Eco Settings | | | | | Network Conf. |
| | | | | | Clear Settings |

a. C48xW/C48xFN/C48xFW series only.

b. C48xFN/C48xFW series only.

c. C48x/C48xW series only.

d. This option only appears when small amount of toner is left in the cartridge.

e. C48xW/C48xFW series only.

Machine's basic settings



You change the machine's setting set in the machine from Samsung Easy Printer Manager or SyncThru™ Web Service.

- If your machine is connected to the local, you can set the machine's setting from **Samsung Easy Printer Manager > Advanced Setting > Device Settings** (see "Using Samsung Easy Printer Manager" on page 268).
- If your machine is connected to the network, you can set the machine's setting from **SyncThru™ Web Service > Settings tab > Machine Settings** (see "Using SyncThru™ Web Service" on page 265).

After installation is complete, you may want to set the machine's default settings.

To change the machine's default settings, follow these steps:



It may be necessary to press **OK** to navigate to lower-level menus for some models.

- 1 Select  (**Menu**) button on the control panel.
- 2 Press **System Setup > Machine Setup**.

3 Select the option you want, then press **OK**.

- **Language:** change the language that is displayed on the control panel.
- **Date & Time:** When you set the time and date, they are used in delay fax and delay print. They are printed on reports. If, however, they are not correct, you need to change it for the correct time being.



Enter the correct time and date using arrows or numeric keypad (see "Keypad letters and numbers" on page 226).

- Month = 01 to 12
- Day = 01 to 31
- Year = requires four digits
- Hour = 01 to 12
- Minute = 00 to 59

- **Clock Mode:** You can set your machine to display the current time using either a 12-hour or 24-hour format.
- **Power Save:** When you are not using the machine for a while, use this feature to save power.

Machine's basic settings



- When you press the **Power/Wake Up** button, start printing, or a fax is received, the product will wake up from the power saving mode.
- Press  (**Menu**) > **System Setup** > **Machine Setup** > **Wakeup Event** > **On** on the control panel. When you press any button except **Power/Wake Up** button, the machine wake up from the power save mode.

- **Altitude Adj.:** Print quality is affected by atmospheric pressure, which atmospheric pressure is determined by the height of the machine above sea level. Before you set the altitude value, determine the altitude where you are (see "Altitude adjustment" on page 225).

4 Select the option you want, then press **OK**.

5 Press **OK** to save the selection.

6 Press  (**Stop/Clear**) to return to ready mode.



Refer to below links to set other settings useful for using the machine.

- See "Entering various characters" on page 226.
- See "Keypad letters and numbers" on page 226.
- See "Setting the paper size and type" on page 48.
- See "Setting up the fax address book" on page 227.

Media and tray

This chapter provides information on how to load print media into your machine.

Selecting print media

You can print on a variety of print media, such as plain paper, envelopes, labels, and transparencies. Always use print media that meet the guidelines for use with your machine.

Guidelines for select the print media

Print media that does not meet the guidelines outlined in this user's guide may cause the following problems:

- Poor print quality
- Increased paper jams
- Premature wear on the machine.

Properties, such as weight, composition, grain, and moisture content, are important factors that affect the machine's performance and the output quality. When you choose print materials, consider the following:

- The type, size, and weight of the print media for your machine are described in print media specifications (see "Print media specifications" on page 127).
- Desired outcome: The print media you choose should be appropriate for your project.
- Brightness: Some print media are whiter than others and produce sharper, more vibrant images.

- Surface smoothness: The smoothness of the print media affects how crisp the printing looks on the paper.



- Some print media may meet all of the guidelines in this user's guide and still not produce satisfactory results. This may be the result of the sheets characteristics, improper handling, unacceptable temperature and humidity levels, or other variables over which cannot be controlled.
- Before purchasing large quantities of print media, ensure that it meets the requirements specified in this user's guide.



- Using print media that does not meet these specifications may cause problems or require repairs. Such repairs are not covered by Samsung's warranty or service agreements.
- The amount of paper put into the tray may differ according to media type used (see "Print media specifications" on page 127).
- Make sure not to use the inkjet photo paper with this machine. It could cause damage to the machine.
- Using flammable print media can cause a fire.
- Use designated print media (see "Print media specifications" on page 127).



The use of flammable media or foreign materials left in the printer may lead to overheating of the unit and, in rare cases may cause a fire.

The amount of paper put into the tray may differ according to media type used (see "Print media specifications" on page 127).

Media and tray

Tray overview

To change the size, you need to adjust the paper guides.

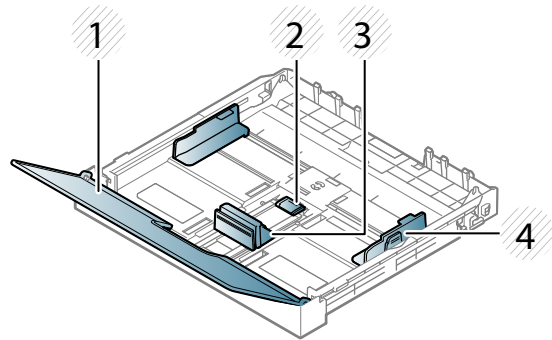

- 1 Paper cover
- 2 Guide lock
- 3 Paper length guide
- 4 Paper width guide



If you do not adjust the guide, it may cause paper registration, image skew, or jamming of the paper.

Media and tray

Loading paper in the tray



Illustrations on this user's guide may differ from your machine depending on its options or models. Check your machine type (see "Front view" on page 21).

- 1 Pull out the paper tray (see "Tray overview" on page 41).

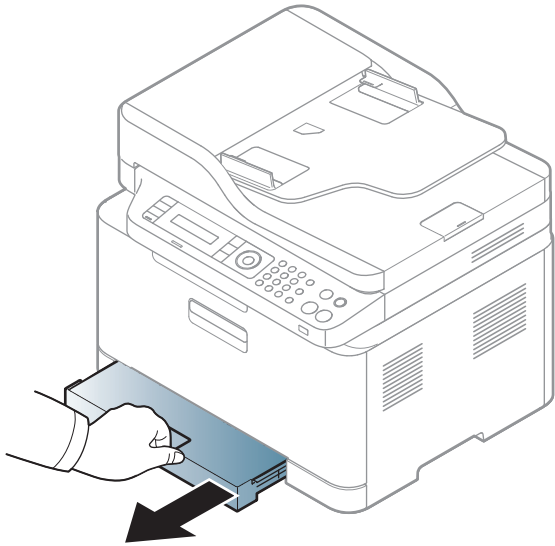

- 2 Open the paper cover.

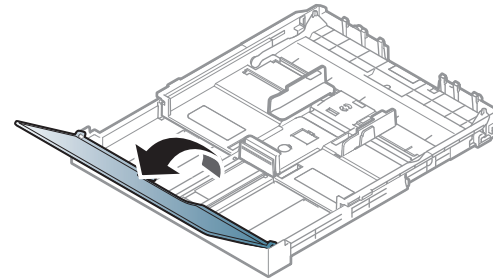

- 3 Squeeze and the paper width guide and paper length lever to locate them in the correct paper size slot marked at the bottom of the tray to adjust to the size.

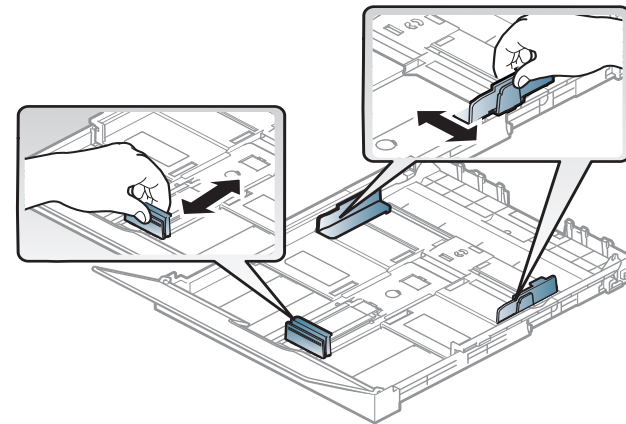

Media and tray

- 4 Flex or fan the edge of the paper stack to separate the pages before loading papers.

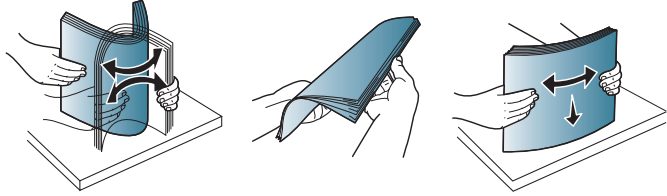

- 5 Place the paper with the side you want to print facing up.

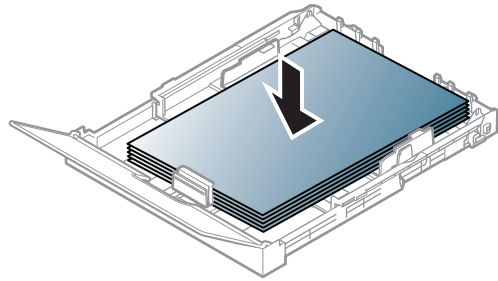

For paper smaller than A4-sized, press and unlatch the guide lock in the tray, push the tray in manually. Then adjust the paper length guide and paper width guide.

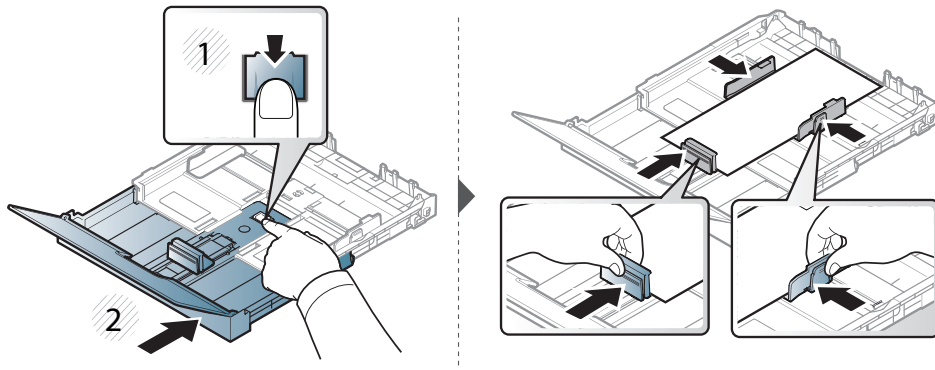

For paper longer than Legal-sized, press and unlatch the guide lock in the tray, pull the tray out manually. Then adjust the paper length guide and paper width guide.

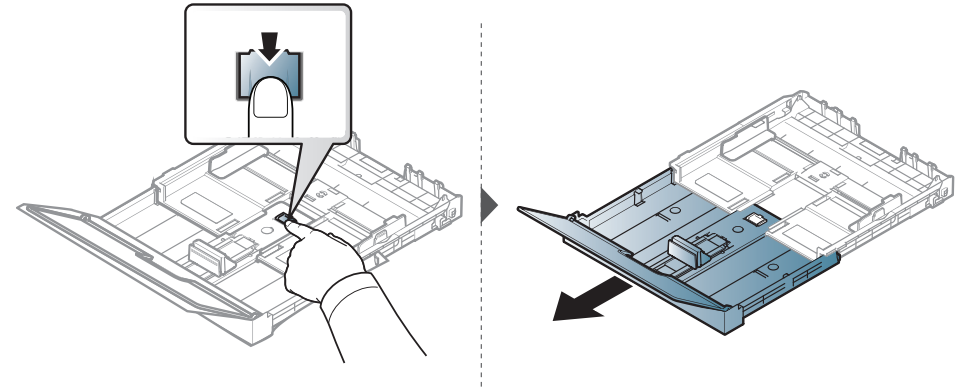

- Do not push the paper width guide too far causing the media to buckle.
- Do not use a paper with a leading-edge curl, it may cause a paper jam or the paper can be wrinkled.

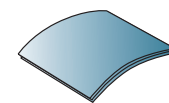
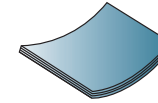
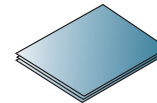

- If you do not adjust the paper width guide, it may cause paper jams.

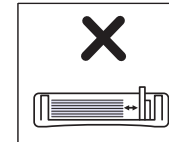
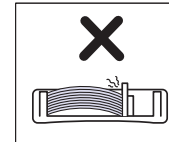
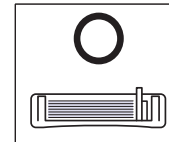

Media and tray

- 6 Squeeze the paper width guide and slide it to the edge of the paper stack without causing it to buckle.

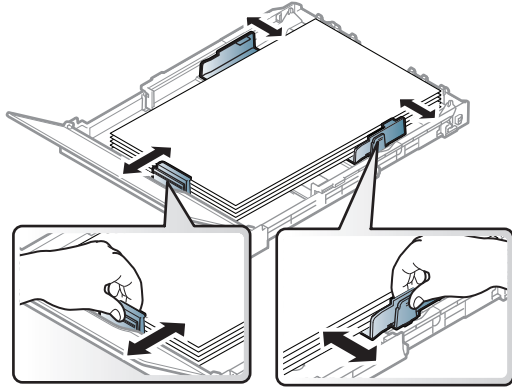

- 7 Close the paper cover.

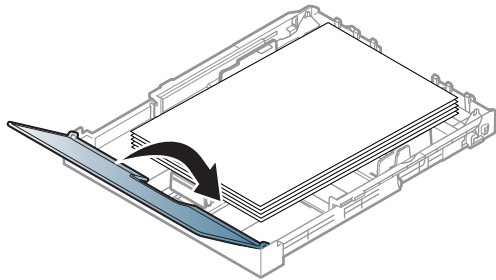

- 8 Insert the paper tray.

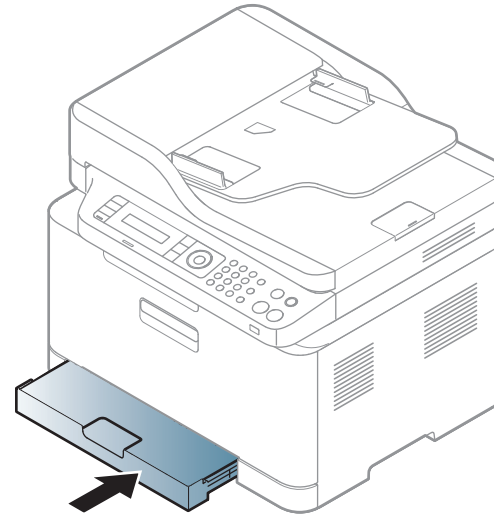

- 9 When you print a document, set the paper type and size for the tray (see "Setting the paper size and type" on page 48).

The tray is preset to Letter or A4 size, depending on your country. To change the size to A4 or Letter, you must adjust the lever and paper width guide properly.

Media and tray

- 1 Pull the tray out of the machine. Open the paper cover and remove paper from the tray if necessary.
- 2 If you want to change the size to Letter, hold the lever at the back of the tray, and rotate the lever clockwise. You can see the lever when you move the paper length guide to the legal-sized paper (LGL).

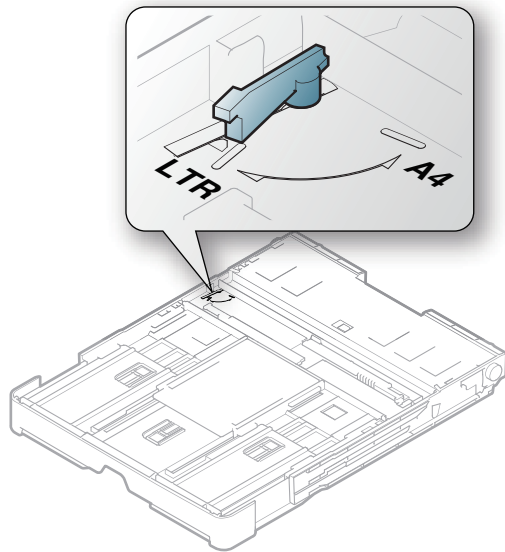

- 3 Squeeze the paper width guide and slide it to the edge of the lever.

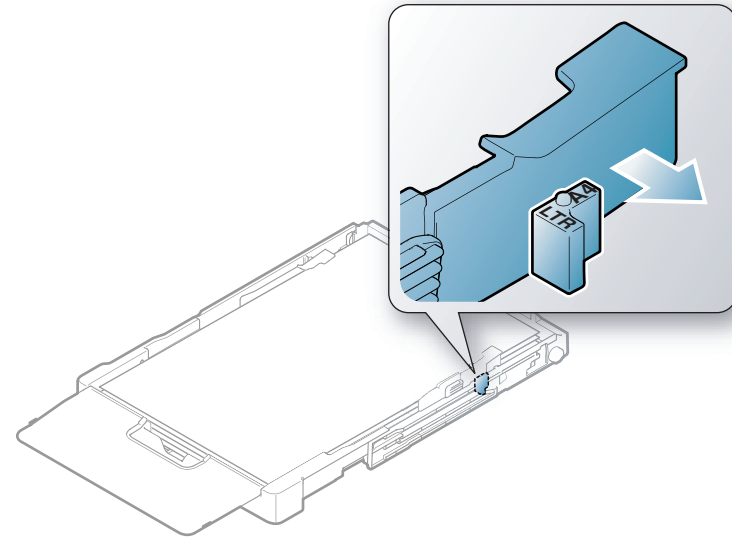

If you want to change the size to A4, first move the paper width guide to left and rotate the lever counterclockwise. If you force the lever, it could damage the tray.

Media and tray

Printing on special media



- When using special media, we recommend you feed one sheet at a time (see "Print media specifications" on page 127).

The table below shows the special media usable in tray.

The paper setting in the machine and driver should match to print without a paper mismatch error.



The paper setting in the machine and driver should match to print without a paper mismatch error.

- You change the paper setting set in the machine from Samsung Easy Printer Manager program or SyncThru™ Web Service.
 - If your machine is connected to the local, you can set the machine's setting from **Samsung Easy Printer Manager > Advanced Setting > Device Settings** (see "Using Samsung Easy Printer Manager" on page 268).
 - If your machine is connected to the network, you can set the machine's setting from **SyncThru™ Web Service > Settings tab > Machine Settings** (see "Using SyncThru™ Web Service" on page 265).
- You can set it using **System Setup > Paper Setup** > select you want **Paper Size** or **Paper Type** button on the control panel.

To see paper weights for each sheet, refer to "Print media specifications" on page 127.

| Types | Tray ^a |
|--------------|-------------------|
| Plain | ● |
| Thick | ● |
| Thin | ● |
| Bond | ● |
| Color | ● |
| CardStock | ● |
| Labels | ● |
| Preprinted | ● |
| Cotton | ● |
| Recycled | ● |
| Archive | ● |
| Glossy Photo | ● |
| Matte Photo | ● |

a. The paper types available manual feeding in tray.

(●: Supported)

Media and tray

Labels

To avoid damaging the machine, use only labels designed for use in laser printers.

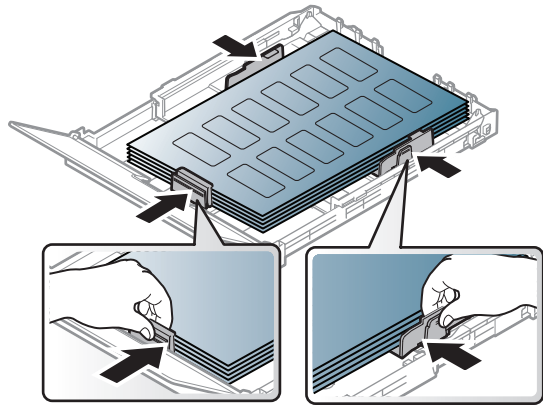

- When selecting labels, consider the following factors:
 - **Adhesives:** Should be stable at your machine's fusing temperature about 170°C (338°F).
 - **Arrangement:** Only use labels with no exposed backing between them. Labels can peel off sheets that have spaces between the labels, causing serious jams.
 - **Curl:** Must lie flat with no more than 13 mm of curl in any direction.
 - **Condition:** Do not use labels with wrinkles, bubbles, or other indications of separation.
- Make sure that there is no exposed adhesive material between labels. Exposed areas can cause labels to peel off during printing, which can cause paper jams. Exposed adhesive can also cause damage to machine components.

- Do not run a sheet of labels through the machine more than once. The adhesive backing is designed for only a single pass through the machine.
- Do not use labels that are separating from the backing sheet or are wrinkled, bubbled, or otherwise damaged.

Card stock/ Custom-sized paper

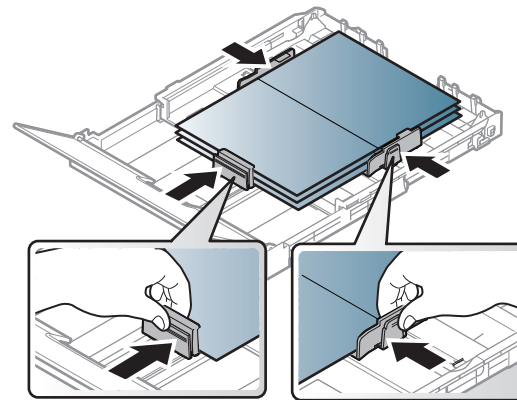

- In the software application, set the margins to at least 6.4 mm (0.25 inches) away from the edges of the material.

Media and tray

Preprinted paper

When loading preprinted paper, the printed side should be facing up with an uncurled edge at the front. If you experience problems with paper feeding, turn the paper around. Note that print quality is not guaranteed.

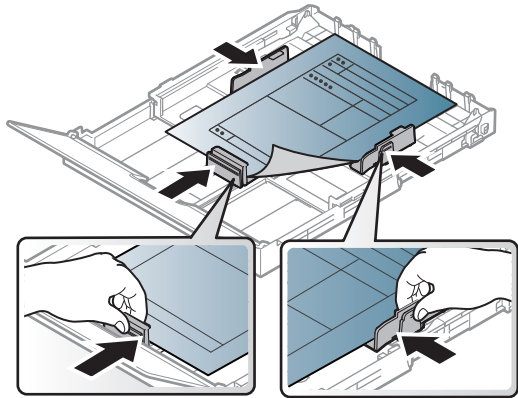

- Must be printed with heat-resistant ink that will not melt, vaporize, or release hazardous emissions when subjected to the machine's fusing temperature for 0.1 second (about 170°C (338°F)).
- Preprinted paper ink must be non-flammable and should not adversely affect machine rollers.
- Before you load preprinted paper, verify that the ink on the paper is dry. During the fusing process, wet ink can come off preprinted paper, reducing print quality.

Setting the paper size and type

After loading paper in the paper tray, set the paper size and type using the control panel buttons.



The paper setting in the machine and driver should match to print without a paper mismatch error.

- You change the paper setting set in the machine from Samsung Easy Printer Manager program or SyncThru™ Web Service.
 - If your machine is connected to the local, you can set the machine's setting from **Samsung Easy Printer Manager > Advanced Setting > Device Settings** (see "Using Samsung Easy Printer Manager" on page 268).
 - If your machine is connected to the network, you can set the machine's setting from **SyncThru™ Web Service > Settings tab > Machine Settings** (see "Using SyncThru™ Web Service" on page 265).
- You can set it using **System Setup > Paper Setup > select you want Paper Size or Paper Type** button on the control panel.

- 1 Select  (**Menu**) button on the control panel.
- 2 Press **System Setup > Paper Setup > Paper Size or Paper Type**.
- 3 Select the tray and the option you want.
- 4 Press **OK** to save the selection.

Media and tray

5 Press  (**Stop/Clear**) to return to ready mode.



- If you want to use special-sized paper such as billing paper, select the **Paper** tab > **Size** > **Edit...** and set **Custom Paper Size Settings** in the **Printing Preferences** (see "Opening printing preferences" on page 56).

Using the output support



The surface of the output tray may become hot if you print a large number of pages at once. Make sure that you do not touch the surface, and do not allow children near it.

The printed pages stack on the output support, and the output support will help the printed pages to align. The printer sends output to the output tray by default.

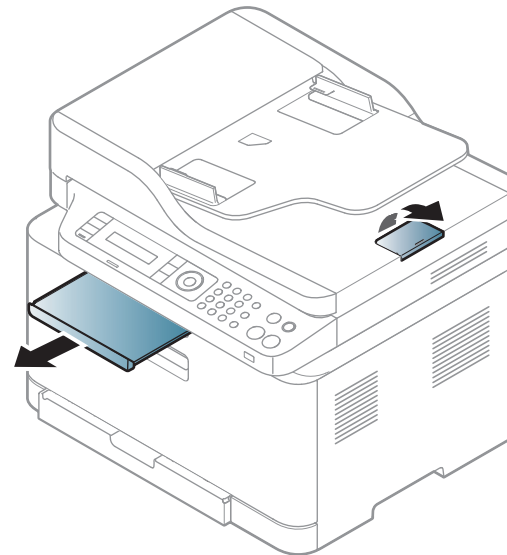

Media and tray



Illustrations on this user's guide may differ from your machine depending on its options or models. Check your machine type (see "Front view" on page 21).

Preparing originals

- Do not load paper smaller than 142 x 148 mm (5.6 x 5.8 inches) or larger than 216 x 356 mm (8.5 x 14 inches).
- Do not attempt to load the following s of paper, in order to prevent paper jam, low print quality and machine damage.
 - Carbon-paper or carbon-backed paper
 - Coated paper
 - Onion skin or thin paper
 - Wrinkled or creased paper
 - Curled or rolled paper
 - Torn paper
- Remove all staples and paper clips before loading.
- Make sure any glue, ink, or correction fluid on the paper is completely dry before loading.
- Do not load originals that include different sizes or weights of paper.
- Do not load booklets, pamphlets, transparencies, or documents with other unusual characteristics.

Loading originals

You can use the scanner glass or the document feeder to load an original for copying, scanning, and sending a fax.



Illustrations on this user's guide may differ from your machine depending on its options or models. Check your machine type (see "Front view" on page 21).

On the scanner glass

Using the scanner glass, you can copy or scan originals. You can get the best scan quality, especially for colored or gray-scaled images. Make sure that no originals are in the document feeder. If an original is detected in the document feeder, the machine gives it priority over the original on the scanner glass.

Media and tray

- 1 Lift and open the scanner lid.

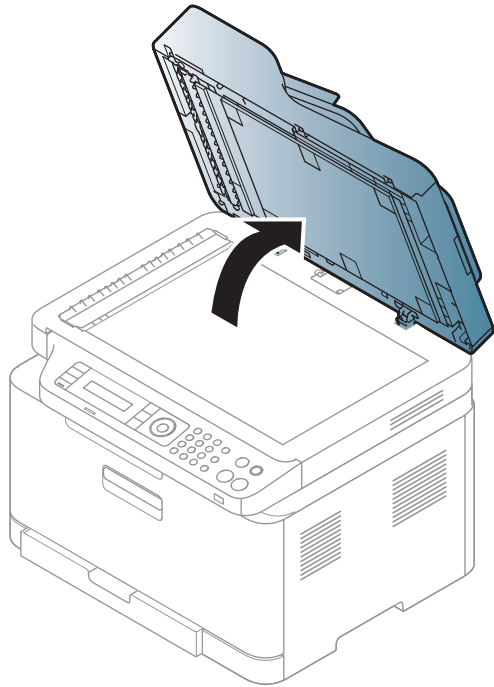

- 2 Place the original face down on the scanner glass. Align it with the registration guide at the top left corner of the glass.

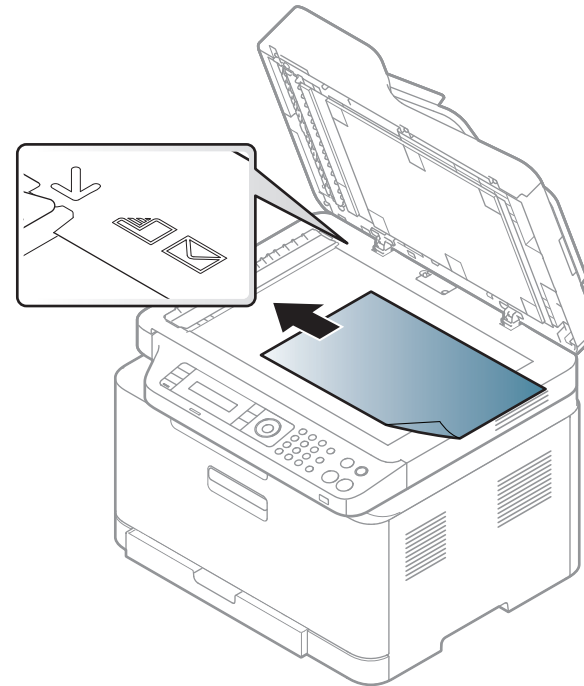

- 3 Close the scanner lid.

Media and tray



- Leaving the scanner lid open while copying may affect copy quality and toner consumption.
- Dust on the scanner glass may cause black spots on the printout. Always keep it clean (see "Cleaning the machine" on page 95).
- If you are copying a page from a book or magazine, lift the scanner lid until its hinges are caught by the stopper and then close the lid. If the book or magazine is thicker than 30 mm, start copying with the scanner lid open.



- Be careful not to break the scanner glass. You may get hurt.
- Do not put hands while closing the scanner lid. The scanner lid may fall on your hands and get hurt.
- Do not look into the light from inside of the scanner while copying or scanning. It is harmful to eyes.

In the document feeder

- 1 Flex or fan the edge of the paper stack to separate the pages before loading originals.

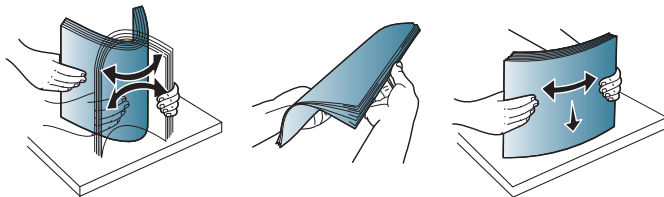

- 2 Load the original face up into the document feeder input tray. Make sure that the bottom of the original stack matches the paper size marked on the document input tray.

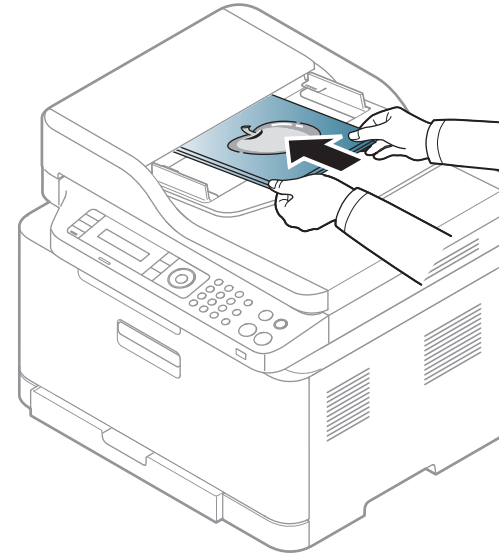

Media and tray

- 3 Adjust the document feeder width guides to the paper size.

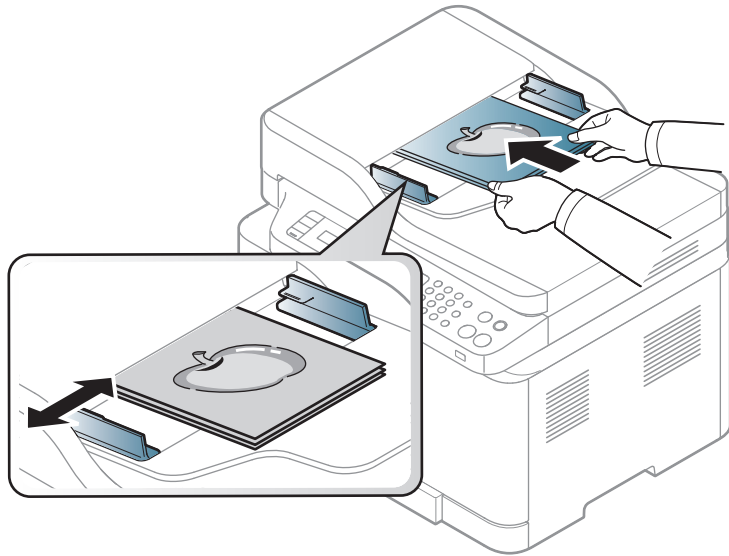

Dust on the document feeder glass may cause black lines on the printout. Always keep the glass clean (see "Cleaning the machine" on page 95).

Basic printing



For special printing features, refer to the Advanced Guide (see "Using advanced print features" on page 231).

Printing



- Mac printing (see "Mac printing" on page 238).
- Linux printing (see "Linux printing" on page 240).

The following **Printing Preferences** window is for Notepad in Windows 7. Your **Printing Preferences** window may differ, depending on your operating system or the application you are using.

- 1 Open the document you want to print.
- 2 Select **Print** from the **File** menu.

- 3 Select your machine from the **Select Printer** list.

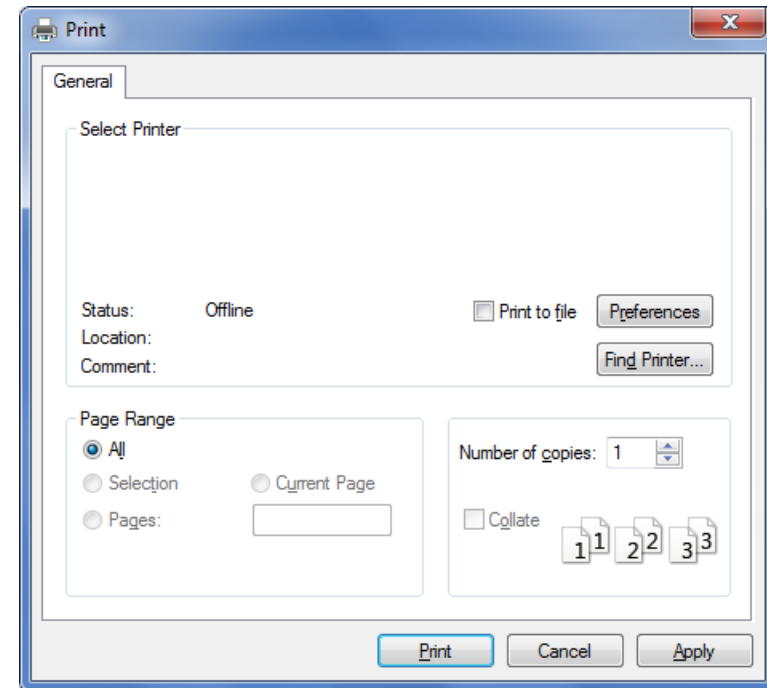

- 4 The basic print settings including the number of copies and print range are selected within the **Print** window.





To take advantage of the advanced printing features, click **Properties** or **Preferences** from the **Print** window (see "Opening printing preferences" on page 56).

- 5 To start the print job, click **OK** or **Print** in the **Print** window.

Basic printing

Canceling a print job





If the print job is waiting in the print queue or print spooler, cancel the job as follows:

- You can access this window by simply double-clicking the machine icon () in the Windows task bar.
- You can also cancel the current job by pressing  (**Stop/Clear**) on the control panel.

Basic printing

Opening printing preferences



- The **Printing Preferences** window that appears in this user's guide may differ depending on the machine in use.
- When you select an option in **Printing Preferences**, you may see a warning mark  or . An  mark means you can select that certain option but it is not recommended, and an  mark means you cannot select that option due to the machine's setting or environment.
- For Windows 8 user, see "Opening more settings" on page 276.

- 1 Open the document you want to print.
- 2 Select **Print** from the file menu. The **Print** window appears.
- 3 Select your machine from the **Select Printer**.
- 4 Click **Properties** or **Preferences**.



The screenshot may differ depending on model.

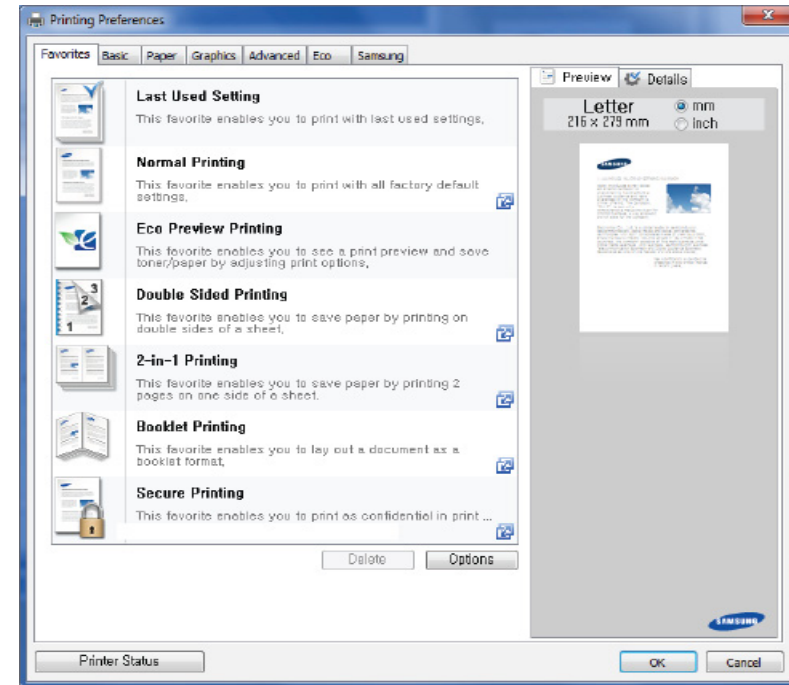

- You can apply **Eco** features to save paper and toner before printing (see "Easy Eco Driver" on page 261).
- You can check the machine's current status pressing the **Printer Status** button (see "Using Samsung Printer Status" on page 271).
- The printer driver includes a user interface that is optimized for touchscreens. To use this UI, click **Samsung Printer Center > Device Options** and then select **Stylish User Interface** (see "Using Samsung Printer Center" on page 262).

Basic printing

Using a favorite setting

The **Favorites** option, which is visible on each preferences tab except for the **Samsung** tab, allows you to save the current preferences for future use.

To save a **Favorites** item, follow these steps:

- 1 Change the settings as needed on each tab.
- 2 Enter a name for the item in the **Favorites** input box.

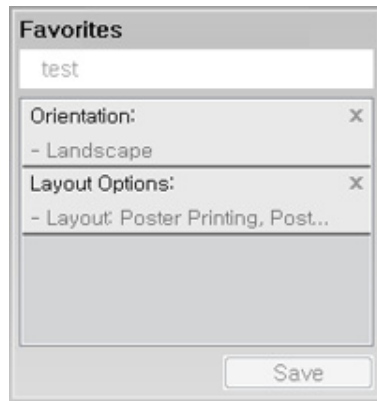

- 3 Click **Save**.
- 4 Enter name and description, and then select the desired icon.
- 5 Click **OK**. When you save **Favorites**, all current driver settings are saved.



To use a saved setting, select it in the **Favorites** tab. The machine is now set to print according to the settings you have selected. To delete saved settings, select it in the **Favorites** tab and click **Delete**.

Using help

Click the option you want to know on the **Printing Preferences** window and press **F1** on your keyboard.

Basic printing

Eco printing

The **Eco** function cuts toner consumption and paper usage. The **Eco** function allows you to save print resources and lead you to eco-friendly printing.

If you press the **Eco** button from the control panel, eco mode is enabled. The default setting of Eco mode is **Multiple Pages per Side (2)** and **Toner Save**. Some features may not be available depending on the model.



- You change the machine's setting set in the machine from Samsung Easy Printer Manager or SyncThru™ Web Service.
 - If your machine is connected to the local, you can set the machine's setting from **Samsung Easy Printer Manager > Advanced Setting > Device Settings** (see "Using Samsung Easy Printer Manager" on page 268).
 - If your machine is connected to the network, you can set the machine's setting from **SyncThru™ Web Service > Settings tab > Machine Settings** (see "Using SyncThru™ Web Service" on page 265).



Depending on the printer driver you use, Skip blank pages may not work properly. If Skip blank pages feature does not work properly, set the feature from the Easy Eco Driver (see "Easy Eco Driver" on page 261).

Setting Eco mode on the control panel

- 1 Select  (**Menu**) > **System Setup** > **Machine Setup** > **Eco Settings** on the control panel.
- 2 Select the option you want and press **OK**.
 - **Default Mode:** Select this to turn on or off the eco mode.
 - **Off:** Set the eco mode off.
 - **On:** Set the eco mode on.
- 3 Press **OK** to save the selection.



If you set the eco mode on with a password from the SyncThru™ Web Service (**Settings tab > Machine Settings > System > Eco Settings**) or Samsung Easy Printer Manager (**Advanced Setting > Device Settings > Eco**), the **On force** message appears. You have to enter the password to change the eco mode status.

- **Select Temp.:** Follow the settings from SyncThru™ Web Service or Samsung Easy Printer Manager. Before you select this item, you must set the eco function in SyncThru™ Web Service (**Settings tab > Machine Settings > System > Eco Settings**) or Samsung Easy Printer Manager (**Advanced Setting > Device Settings > Eco**).
 - **Default Eco:** The machine is set to **Default Eco** mode.
 - **Custom Eco:** Change any necessary values.

Basic printing

Setting eco mode on the driver

Open the Eco tab to set Eco mode. When you see the eco image (), that means the eco mode is currently enabled.

Eco options

- **Printer Default:** Follows the settings from the machine's control panel.
- **None:** Disables Eco mode.
- **Eco Printing:** Enables eco mode. Activate the various Eco items you want to use.
- **Password:** If the administrator fixed to enable the Eco mode, you have to enter the password to change the status.

Result simulator

Result Simulator shows the estimated results of reduced emissions of carbon dioxide, used electricity, and the amount of saved paper in accordance with the settings you selected.

- The results are calculated on the basis that the total number of printed paper is one hundred without a blank page when the Eco mode is disabled.
- Refers to the calculation coefficient about CO₂, energy, and paper from **IEA**, the index of Ministry of Internal Affairs and Communication of Japan and www.remanufacturing.org.uk. Each model has a different index.
- The power consumption in printing mode refers to the average printing power consumption of this machine.

- The actual amount displayed is only an estimate as the actual amount may differ depending on the operating system used, computing performance, application software, connection method, media type [thickness], media size, job complexity, etc.

Basic copying





For special printing features, refer to the Advanced Guide (see "Copy" on page 207).



If you need to cancel the copying job during the operation, press  (**Stop/Clear**) and the copying will stop.

Basic copy

- 1** C48xW series: Make sure that the **Scan to** button's LED is off.
C48xFN/C48xFW series: Select  (copy) on the control panel.
- 2** Select  (**Menu**) > **Copy Feature** on the control panel.
- 3** Place a single document face down on the document glass, or load the documents face up into the document feeder (see "Loading originals" on page 50).
- 4** If you want to customize the copy settings including **Reduce/Enlarge**, **Darkness**, **Original Type** and more by using the control panel buttons (see "Changing the settings for each copy" on page 60).
- 5** Enter the number of copies using the arrow or number keypad, if necessary.
- 6** Press  (**Start**).

Changing the settings for each copy

Your machine provides default settings for copying so that you can quickly and easily make a copy.





- If you press the  (**Stop/Clear**) button twice while setting the copy options, all of the options you have set for the current copy job will be canceled and returned to their default status. Or, they will automatically return to their default status after the machine completes the copy in progress.
- Accessing menus may differ from model to model (see "Accessing the menu" on page 34).
- It may be necessary to press **OK** to navigate to lower-level menus for some models.

Darkness



If you have an original containing faint marking and dark images, you can adjust the brightness to make a copy that is easier to read.

Basic copying

- 1 C48xW series: Make sure that the **Scan to** button's LED is off.
C48xFN/C48xFW series: Select  (copy) on the control panel.
- 2 Select  (**Menu**) > **Copy Feature** > **Darkness** on the control panel.
- 3 Select the option you want and press **OK**.
For example, the **Light+5** being the lightest, and the **Dark+5** being the darkest.
- 4 Press  (**Stop/Clear**) to return to ready mode.

Original

The original setting is used to improve the copy quality by selecting the document for the current copy job.

- 1 C48xW series: Make sure that the **Scan to** button's LED is off.
C48xFN/C48xFW series: Select  (copy) on the control panel.
- 2 Select  (**Menu**) > **Copy Feature** > **Original Type** on the control panel.
- 3 Select the option you want and press **OK**.
 - **Text**: Use for originals containing mostly text.
 - **Text/Photo**: Use for originals with mixed text and photographs.



If texts in the printout is blurry, select **Text** to get the clear texts.

- **Photo**: Use when the originals are photographs.
- **Magazine**: Use when the originals are magazine.

- 4 Press  (**Stop/Clear**) to return to ready mode.



Reduced or enlarged copy

You can reduce or enlarge the size of a copied image from 25% to 400% from the document feeder or scanner glass.



- This feature may not be available depending on model or optional goods (see "Variety feature" on page 10).
- If the machine set to Eco mode, reduce and enlarge features are not available.



To select from the predefined copy sizes

- 1 C48xW series: Make sure that the **Scan to** button's LED is off.
C48xFN/C48xFW series: Select  (copy) on the control panel.
- 2 Select  (**Menu**) > **Copy Feature** > **Reduce/Enlarge** on the control panel.

Basic copying

- 3 Select the option you want and press **OK**.
- 4 Press  (**Stop/Clear**) to return to ready mode.

To scale the copy by directly entering the scale rate

- 1 C48xW series: Make sure that the **Scan to** button's LED is off.
C48xFN/C48xFW series: Select  (copy) on the control panel.
- 2 Select  (**Menu**) > **Copy Feature** > **Reduce/Enlarge** > **Custom** on the control panel.
- 3 Enter the copy size you want using the numeric keypad.
- 4 Press **OK** to save the selection.
- 5 Press  (**Stop/Clear**) to return to ready mode.

 When you make a reduced copy, black lines may appear at the bottom of your copy.

ID card copying

Your machine can print 2-sided originals on one sheet.

The machine prints one side of the original on the upper half of the paper and the other side on the lower half without reducing the size of the original. This feature is helpful for copying a small-sized item such as business card.



- The original must be placed on the scanner glass to use this feature.
- If the machine set to Eco mode, this feature is not available.

Depending on the model, the operating procedure may differ.

- 1 Press **ID Copy** on the control panel.
- 2 Place the front side of an original facing down on the scanner glass where arrows indicate as shown. Then, close the scanner lid.

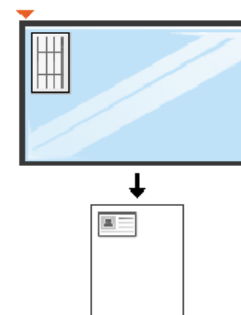

Basic copying

3 **Place Front Side and Press [Start]** appears on the display.

4 Press  (**Start**).

Your machine begins scanning the front side and shows **Place Back Side and Press [Start]**.

5 Turn the original over and place it on the scanner glass where arrows indicate as shown. Then, close the scanner lid.

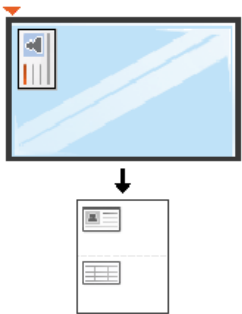

6 Press  (**Start**) button.

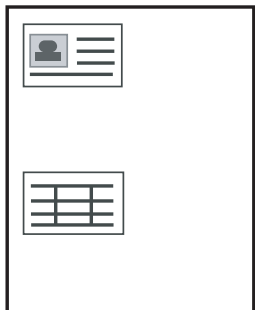

- If you do not press the  (**Start**) button, only the front side will be copied.
- If the original is larger than the printable area, some portions may not be printed.

Basic scanning



For special scanning features, refer to the Advanced Guide (see "Scan features" on page 241).

Basic Scanning

This is the normal and usual procedure for scanning originals.

This is a basic scanning method for USB-connected machine.



- It may be necessary to press **OK** to navigate to lower-level menus for some models.
- If you want to scan using the network, refer to the Advanced Guide (see "Scanning from network connected machine" on page 242).
- C48xW series only support **Scan to** key on the control panel (see "Basic scanning method" on page 241).

- 1 Place a single document face down on the document glass, or load the documents face up into the document feeder (see "Loading originals" on page 50).
- 2 C48xW series: Press **Scan to** > **Scan to PC** > **Local PC** on the control panel.

C48xFN/C48xFW series: Select  (scan) > **Scan to PC** > **Local PC** on the control panel.



If you see **Not Available** message, check the port connection, or select **Enable Scan from Device Panel** in **Samsung Easy Printer Manager** > **Advanced Setting** > **Scan to PC Settings**.

3

Select the scan destination you want and press **OK**.

Default setting is **My Documents**.



- You can create and save the frequently used settings as a profile list. Also you can add and delete the profile and save each profile to a different path.
- To change the **Samsung Easy Printer Manager** > **Advanced Setting** > **Scan to PC Settings**.

4

Select the option you want and press **OK**.

5

Scanning begins.



Scanned image is saved in computer's **C:\Users\users name\My Documents**. The saved folder may differ, depending on your operating system or the application you are using.

Basic faxing



- C48xFN/C48xFW series only.
- For special faxing features, refer to the Advanced Guide (see "Fax features" on page 249).



- You cannot use this machine as a fax via the internet phone. For more information ask your internet service provider.
- We recommend using traditional analog phone services (PSTN: Public Switched Telephone Network) when connecting telephone lines to use a fax machine. If you use other Internet services (DSL, ISDN, VoIP), you can improve the connection quality by using the Micro-filter. The Micro-filter eliminates unnecessary noise signals and improves connection quality or Internet quality. Since the DSL Micro-filter is not provided with the machine, contact your Internet service provider for use on DSL Micro-filter.

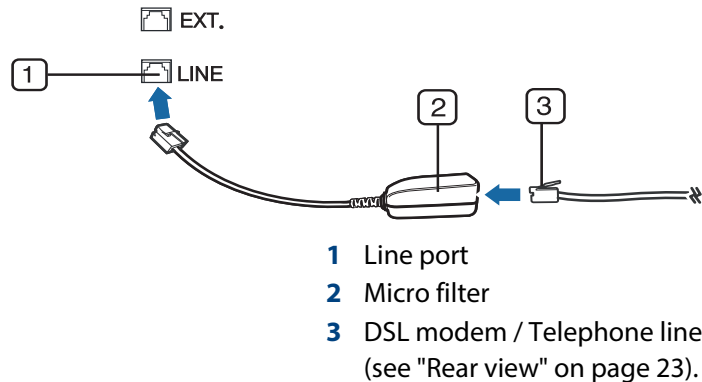

Preparing to fax

Before you send or receive a fax, you need to connect the supplied line cord to your telephone wall jack (see "Rear view" on page 23). Refer to the Quick Installation Guide how to make a connection. The method of making a telephone connection is different from one country to another.

Sending a fax



When you place the originals, you can use either the document feeder or the scanner glass. If the originals are placed on both the document feeder and the scanner glass, the machine will read the originals on the document feeder first, which has higher priority in scanning.

- 1 Place a single document face down on the document glass, or load the documents face up into the document feeder (see "Loading originals" on page 50).
- 2 Select  (fax) on the control panel.
- 3 Adjust the resolution and the darkness to suit your fax needs (see "Adjusting the document settings" on page 67).

Basic faxing

- 4 Enter the destination fax number (see "Keypad letters and numbers" on page 226).
- 5 Press  (**Start**) on the control panel. The machine starts to scan and send the fax to the destinations.





- If you want to send a fax directly from your computer, use Samsung Network PC Fax (see "Sending a fax from your computer" on page 250).
- When you want to cancel a fax job, press  (**Stop/Clear**) before the machine starts transmission.
- If you used the scanner glass, the machine shows the message asking to place another page.

Sending a fax manually

Perform the following to send a fax using  (**On Hook Dial**) on the control panel.



- If your machine is a handset model, you can send a fax using the handset (see "Variety feature" on page 10).

- 1 Place a single document face down on the document glass, or load the documents face up into the document feeder (see "Loading originals" on page 50).
- 2 Select  (fax) on the control panel.
- 3 Adjust the resolution and the darkness to suit your fax needs (see "Adjusting the document settings" on page 67).
- 4 Press  (**On Hook Dial**) on the control panel or lift the handset.
- 5 Enter a fax number using the number keypad on the control panel.
- 6 Press  (**Start**) on the control panel when you hear a high-pitched fax signal from the remote fax machine.



Sending a fax to multiple destinations

You can use the multiple send feature, which allows you to send a fax to multiple locations. Originals are automatically stored in memory and sent to a remote station. After transmission, the originals are automatically erased from memory.



- You cannot send faxes with this feature if you have chosen super fine as an option or if the fax is in color.

Basic faxing

- 1 Place a single document face down on the document glass, or load the documents face up into the document feeder (see "Loading originals" on page 50).
- 2 Select  (fax) on the control panel.
- 3 Adjust the resolution and the darkness to suit your fax needs (see "Adjusting the document settings" on page 67).
- 4 Select  (**Menu**) > **Fax Feature** > **Multi Send** on the control panel.
- 5 Enter the number of the first receiving fax machine and press **OK**.
You can press speed dial numbers or select a group dial number using the  (**Address book**) button.
- 6 Enter the second fax number and press **OK**.
The display asks you to enter another fax number to send the document.
- 7 To enter more fax numbers, press **OK** when **Yes** appears and repeat steps 5 and 6.



You can add up to 10 destinations.

- 8 When you have finished entering fax numbers, select **No** at the **Another No.?** prompt and press **OK**.

The machine begins sending the fax to the numbers you entered in the order in which you entered them.

Receiving a fax

Your machine is preset Fax mode at the factory. When you receive a fax, the machine answers the call on a specified number of rings and automatically receives the fax.

Adjusting the document settings

Before starting a fax, change the following settings according to your original's status to get the best quality.





It may be necessary to press **OK** to navigate to lower-level menus for some models.

Resolution

The default document settings produce good results when using typical text-based originals. However, if you send originals that are of poor quality, or contain photographs, you can adjust the resolution to produce a higher quality fax.

Basic faxing

- 1 Select  (fax) >  (**Menu**) > **Fax Feature** > **Resolution** on the control panel.
- 2 Select the option you want and press **OK**.
 - **Standard:** Originals with normal sized characters.
 - **Fine:** Originals containing small characters or thin lines or originals printed using a dot-matrix printer.
 - **Super Fine:** Originals containing extremely fine detail. **Super Fine** mode is enabled only if the machine with which you are communicating also supports the Super Fine resolution.



- For memory transmission, **Super Fine** mode is not available. The resolution setting is automatically changed to **Fine**.
- When your machine is set to **Super Fine** resolution and the fax machine with which you are communicating does not support **Super Fine** resolution, the machine transmits using the highest resolution mode supported by the other fax machine.



- **Photo Fax:** Originals containing shades of gray or photographs.
- 3 Press  (**Stop/Clear**) to return to ready mode.

Darkness

You can select the degree of darkness of the original document.



The darkness setting is applied to the current fax job. To change the default setting (see "Fax" on page 210).

- 1 Select  (fax) >  (**Menu**) > **Fax Feature** > **Darkness** on the control panel.
- 2 Select a darkness level you want.
- 3 Press  (**Stop/Clear**) to return to ready mode.

Using USB memory device



C48x series do not support USB memory port.

This chapter explains how to use a USB memory device with your machine.

About USB memory

USB memory devices are available with a variety of memory capacities to give you more room for storing documents, presentations, downloaded music and videos, high resolution photographs or whatever other files you want to store or move.

You can do the following tasks on your machine by using a USB memory device.

- Scan documents and save them on a USB memory device
- Print data stored on a USB memory device
- Restore backup files to the machine's memory
- Format the USB memory device
- Check the available memory space

Plugging in a USB memory device

Lift the scanner lid slightly and insert your USB memory device into the USB memory port. Close the scanner lid again before using the device.

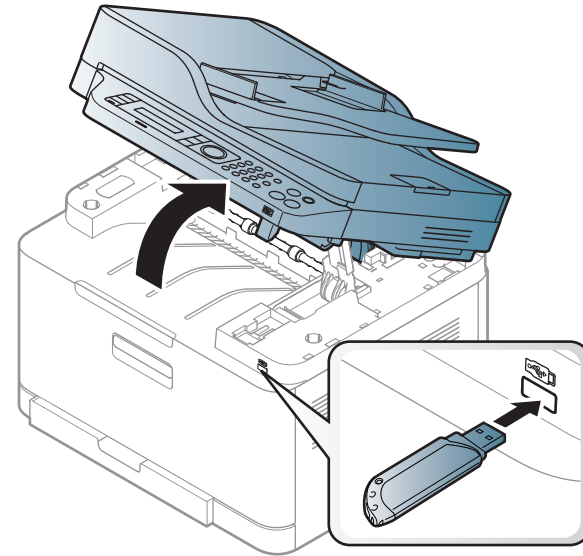

The USB memory port on the front of your machine is designed for USB V1.1 and USB V2.0 memory devices. Your machine supports USB memory devices with FAT16/FAT32 and a sector size of 512 bytes.

Check your USB memory device's file system from your dealer.

Using USB memory device

You must use only an authorized USB memory device with an A plug connector.

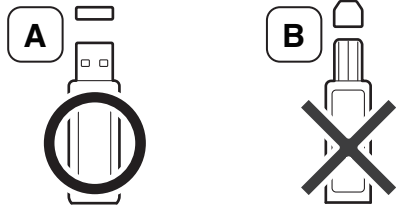

Use only a metal-shielded USB memory device.

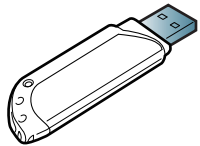

Only use a USB memory device that has obtained compatibility certification; otherwise, the machine might not recognize it.



- Do not remove the USB memory device while the machine is in operation or writing to or reading from USB memory. The machine warranty does not cover damage caused by user's misuse.
- If your USB memory device has certain features such as security settings and password settings, your machine may not automatically detect it. For details about these features, see the user's guide of the USB memory device.

Printing from a USB memory device

You can directly print files stored on a USB memory device.

File is supported by Direct Print option.

- **PRN:** Only files created by provided driver with your machine are compatible.



If you print PRN files created from other machine, the printout would be different.

- **TIFF:** TIFF 6.0 Baseline
- **JPEG:** JPEG Baseline
- **PDF:** PDF 1.7 or lower version

To print a document from a USB memory device

- 1 Insert a USB memory device into the USB memory port on your machine, and then press **Direct USB**.
- 2 Select **USB Print**.

Using USB memory device

- 3 Select the folder or file you want and press **OK**.
If you see [+] or [D] in the front of a folder name, there are one or more files or folders in the selected folder.
- 4 Select the number of copies to be printed or enter the number.
- 5 Press **OK**, **Start** or **Print** to start printing the selected file.
After printing the file, the display asks if you want to print another job.
- 6 Press **OK** when **Yes** appears to print another job, and repeat from step 2.
Otherwise, press the left/right arrow to select **No** and press **OK**.
- 7 Press  (**Stop/Clear**) to return to ready mode.

Scanning to a USB memory device



- Accessing menus may differ from model to model (see "Accessing the menu" on page 34)
- It may be necessary to press **OK** to navigate to lower-level menus for some models.

You can scan a document and save the scanned image onto a USB memory device.



Scanning

- 1 Insert a USB memory device into the USB memory port on your machine.
- 2 Place a single document face down on the document glass, or load the documents face up into the document feeder (see "Loading originals" on page 50).
- 3 Select  (scan) > **Scan To USB** > **OK** on the control panel.
The machine begins scanning.

To scan multiple pages, select **Yes** while **Another Page? Yes/No** appears. After scanning is complete, you can remove the USB memory device from the machine.

Customizing Scan to USB

You can specify image size, file format, or color mode for each scanning to USB job.

- 1 Select  (scan) >  (**Menu**) > **Scan Feature** > **USB Feature** on the control panel.
- 2 Select the setting option you want appears.
 - **Original Size:** Sets the image size.
 - **Original Type:** Sets the original document's.
 - **Resolution:** Sets the image resolution.

Using USB memory device

- **Color Mode:** Sets the color mode. If you select **Mono** in this option, you cannot select JPEG in **File Format**.
- **File Format:** Sets the file format in which the image is to be saved. If you select **JPEG** in this option, you cannot select **Mono** in **Color Mode**.
- **Darkness:** Sets the brightness level to scan an original.

3 Select the desired status you want and press **OK**.

4 Repeat steps 2 and 3 to set other setting options.

5 Press  (**Stop/Clear**) to return to ready mode.

You can change the default scan settings. Refer to the Advanced Guide.

Managing USB memory

You can delete image files stored on a USB memory device one by one or all at once by reformatting the device.



If you see **[+]** or **[D]** in the front of a folder name, there are one or more files or folders in the selected folder.



After deleting files or reformatting a USB memory device, files cannot be restored. Therefore, confirm that you no longer need the data before deleting it.

Deleting an image file

1 Insert a USB memory device into the USB memory port on your machine, and then press **Direct USB**.

2 Select **File Manage > Delete** and press **OK**.

3 Select the file you want to delete and press **OK**.

4 Select **Yes**.

5 Press  (**Stop/Clear**) to return to ready mode.

Formatting a USB memory device

1 Insert a USB memory device into the USB memory port on your machine, and then press **Direct USB**.

2 Select **File Manage > Format** and press **OK**.

3 Select **Yes**.

4 Press  (**Stop/Clear**) to return to ready mode.

Using USB memory device

Viewing the USB memory status

You can check the amount of memory space available for scanning and saving documents.

- 1 Insert a USB memory device into the USB memory port on your machine, and then press **Direct USB**.
- 2 Select **Check Space**.
- 3 The available memory space appears on the display.
- 4 Press  (**Stop/Clear**) to return to ready mode.



3. Maintenance

This chapter provides information about purchasing supplies, accessories and maintenance parts available for your machine.

| | |
|---|-----------|
| • Ordering supplies and accessories | 81 |
| • Available supplies | 82 |
| • Available maintenance parts | 83 |
| • Storing the toner cartridge | 84 |
| • Redistributing toner | 85 |
| • Replacing the toner cartridge | 87 |
| • Replacing the imaging unit | 89 |
| • Replacing the waste toner container | 91 |
| • Monitoring the supplies life | 93 |
| • Setting the toner low alert | 94 |
| • Cleaning the machine | 95 |
| • Tips for moving & storing your machine | 99 |

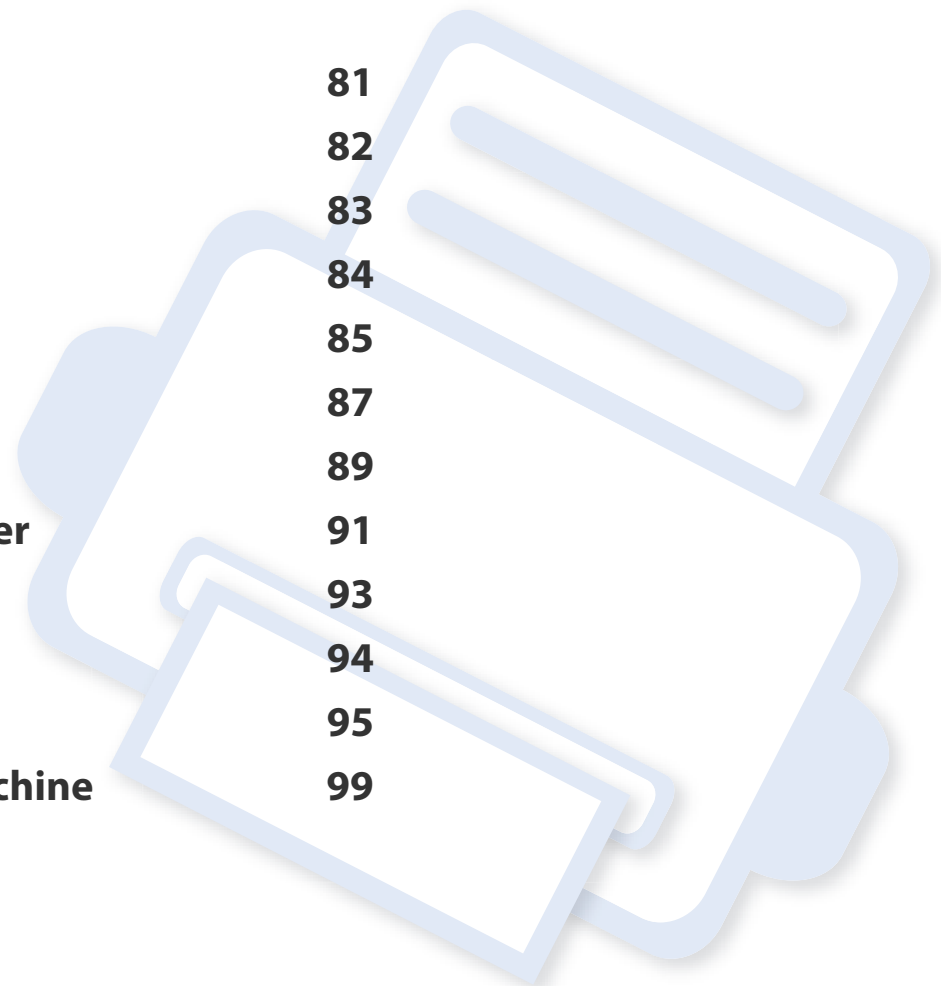

Ordering supplies and accessories



Available accessories may differ from country to country. Contact your sales representatives to obtain the list of available supplies, and maintenance parts.

To order Samsung-authorized supplies, accessories, and maintenance parts, contact your local Samsung dealer or the retailer where you purchased your machine. You can also visit www.samsung.com/supplies, and then select your country/region to obtain the contact information for service.

Available supplies

When supplies reach the end of their life spans, you can order the followings of supplies for your machine:

| Type | Average yield ^a | Part name |
|-----------------------|---|---|
| Toner cartridge | <ul style="list-style-type: none">• Average continuous black cartridge yield: Approx. 1,500 standard pages (Black)• Average continuous color cartridge yield: Approx. 1,000 standard pages (Yellow/Magenta/Cyan) | <ul style="list-style-type: none">• K404 (CLT-K404S): Black• C404 (CLT-C404S): Cyan• M404 (CLT-M404S): MagentaY404 (CLT-Y404S): Yellow |
| Imaging unit | Approx. 16,000 images ^b | CLT-R406 |
| Waste toner container | Approx. 7,000 images ^b | CLT-W406 |

a. Declared yield value in accordance with ISO/IEC 19798. The number of pages may be affected by operating environment, printing interval, graphics, media type and media size.

b. Image counts based on one color on each page. If you print documents in full color (Cyan, Magenta, Yellow, Black), the life of this item will be reduced by 25%.



Depending on the options, percentage of image area and job mode used, the toner cartridge's lifespan may differ.



When purchasing new toner cartridges or other supplies, these must be purchased in the same country as the machine you are using. Otherwise, new toner cartridges or other supplies will be incompatible with your machine due to different configurations of toner cartridges and other supplies according to the specific country conditions.



- **The toner cartridge included in the printer/all-in-one product you purchased is not available for sale and is not guaranteed to be compatible with any other printer.**
- Samsung does not recommend using non-genuine Samsung toner cartridge such as refilled or remanufactured toner. Samsung cannot guarantee non-genuine Samsung toner cartridge's quality. Service or repair required as a result of using non-genuine Samsung toner cartridges will not be covered under the machine's warranty.

Available maintenance parts

You need to replace the maintenance parts at specific intervals to keep the machine in the best condition and avoid print quality and paper feeding problems resulting from the worn-out parts. Maintenance parts are mostly rollers, belts and pads. However, the replacement period and parts may differ depending on the model. Replacing maintenance parts can be performed only by an authorized service provider, dealer, or the retailer where you bought the machine. To purchase maintenance parts, contact the retailer where you bought the machine. The replacement period for the maintenance parts is informed by the "Samsung Printer Status" program. Or on the UI (User Interface) if your machine supports a display screen. The replacement period varies based on the operating system used, computing performance, application software, connecting method, paper type, paper size, and job complexity.

Storing the toner cartridge

Toner cartridges contain components that are sensitive to light, temperature and humidity. Samsung suggests users follow these recommendations to ensure optimal performance, highest quality, and longest life from your new Samsung toner cartridge.

Store this cartridge in the same environment in which the printer will be used. This should be in controlled temperature and humidity conditions. The toner cartridge should remain in its original and unopened package until installation – if original packaging is not available, cover the top opening of the cartridge with paper and store in a dark cabinet.

Opening the cartridge package prior to use dramatically shortens its useful shelf and operating life. Do not store on the floor. If the toner cartridge is removed from the printer, follow the instructions below to store the toner cartridge properly.

- Store the cartridge inside the protective bag from the original package.
- Store lying flat (not standing on end) with the same side facing up as if it were installed in the machine.
- Do not store consumables in any of the following conditions:
 - Temperature greater than 40°C (104°F).
 - Humidity range less than 20% or greater than 80%.
 - An environment with extreme changes in humidity or temperature.
 - Direct sunlight or room light.
 - Dusty places.
 - A car for a long period of time.
 - An environment where corrosive gases are present.
 - An environment with salty air.

Handling instructions

- Do not expose the cartridge to unnecessary vibrations or shock.

Toner cartridge usage

Samsung Electronics does not recommend or approve the use of non-Samsung brand toner cartridges in your printer including generic, store brand, refilled, or remanufactured toner cartridges.



Samsung's printer warranty does not cover damage to the machine caused by the use of a refilled, remanufactured, or non-Samsung brand toner cartridges.

Estimated cartridge life

Estimated cartridge life (the life of the toner cartridge yield) depends on the amount of toner that print jobs require. The actual print yield may vary depending on the print density of the pages you print on, operating environment, percentage of image area, printing interval, media type and/or media size. For example, if you print a lot of graphics, the consumption of the toner is higher and you may need to change the cartridge more often.

Redistributing toner

When the toner cartridge is near the end of its life:

- White streaks or light printing occurs and/or density varies from side to side.
- The **Status** LED blinks orange. The toner-related message saying that the toner is low may appear on the display.
- The computer's Samsung Printing Status program window appears on the computer telling you which color cartridge is low on toner (see "Using Samsung Printer Status" on page 271).

If this happens, you can temporarily improve print quality by redistributing the remaining toner in the cartridge. In some cases, white streaks or light printing will still occur even after you have redistributed the toner.



Illustrations on this user's guide may differ from your machine depending on its options or models. Check your machine type (see "Front view" on page 21).



- Do not use sharp objects such as a knife or scissors to open the toner cartridge package. They might scratch the drum of the cartridge.
- If toner gets on your clothing, wipe it off with a dry cloth and wash clothing in cold water. Hot water sets toner into fabric.
- When opening a scan unit, hold the document feeder and scan unit together.
- Printing even after the toner empty status can cause serious damage to your machine.

Redistributing toner

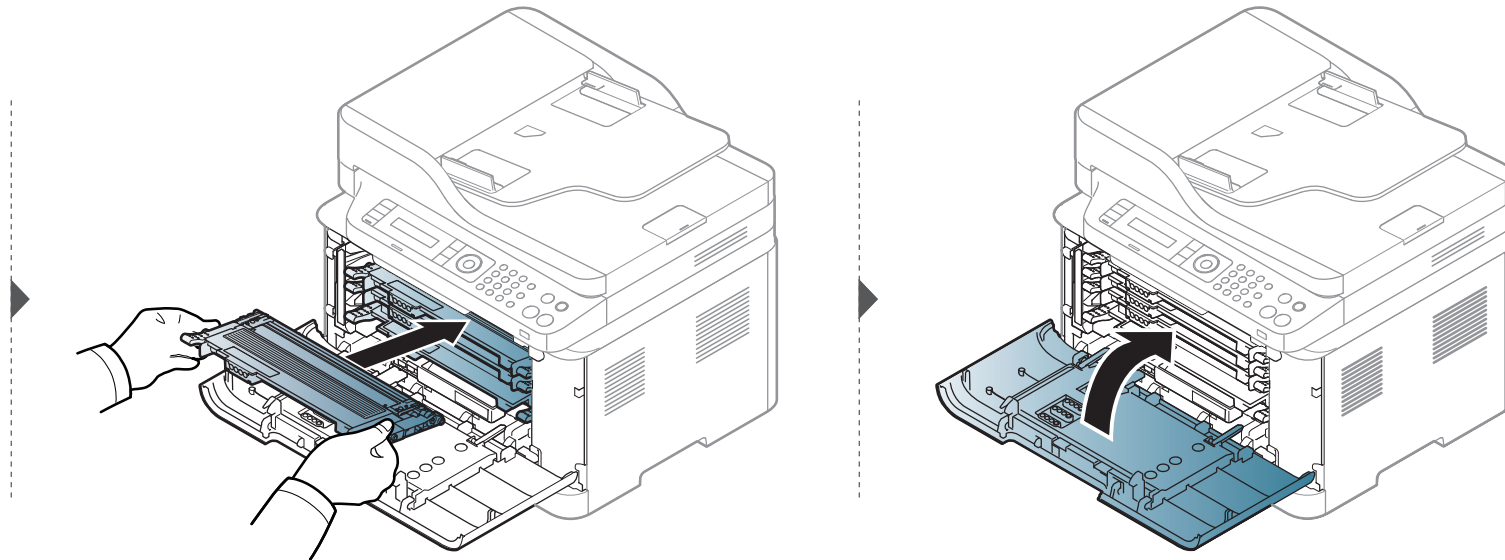
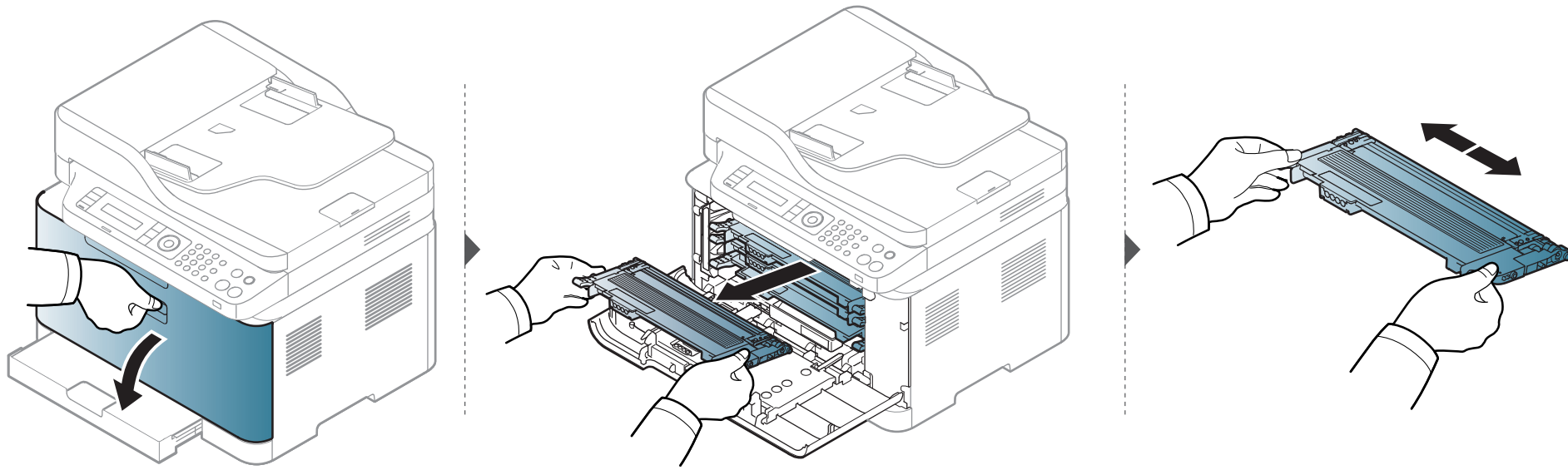

Replacing the toner cartridge

When a toner cartridge has reached the end of life, the Printing Status window appears on the computer, indicating the toner cartridge needs to be placed.



- Shake the toner cartridge thoroughly, it will increase the initial print quality.
- Illustrations on this user's guide may differ from your machine depending on its options or models. Check your machine type (see "Front view" on page 21).



- Do not use sharp objects such as a knife or scissors to open the toner cartridge package. They might scratch the drum of the cartridge.
- If toner gets on your clothing, wipe it off with a dry cloth and wash clothing in cold water. Hot water sets toner into fabric.
- When opening a scan unit, hold the document feeder and scan unit together.
- Printing even after the toner empty status can cause serious damage to your machine.

Replacing the toner cartridge

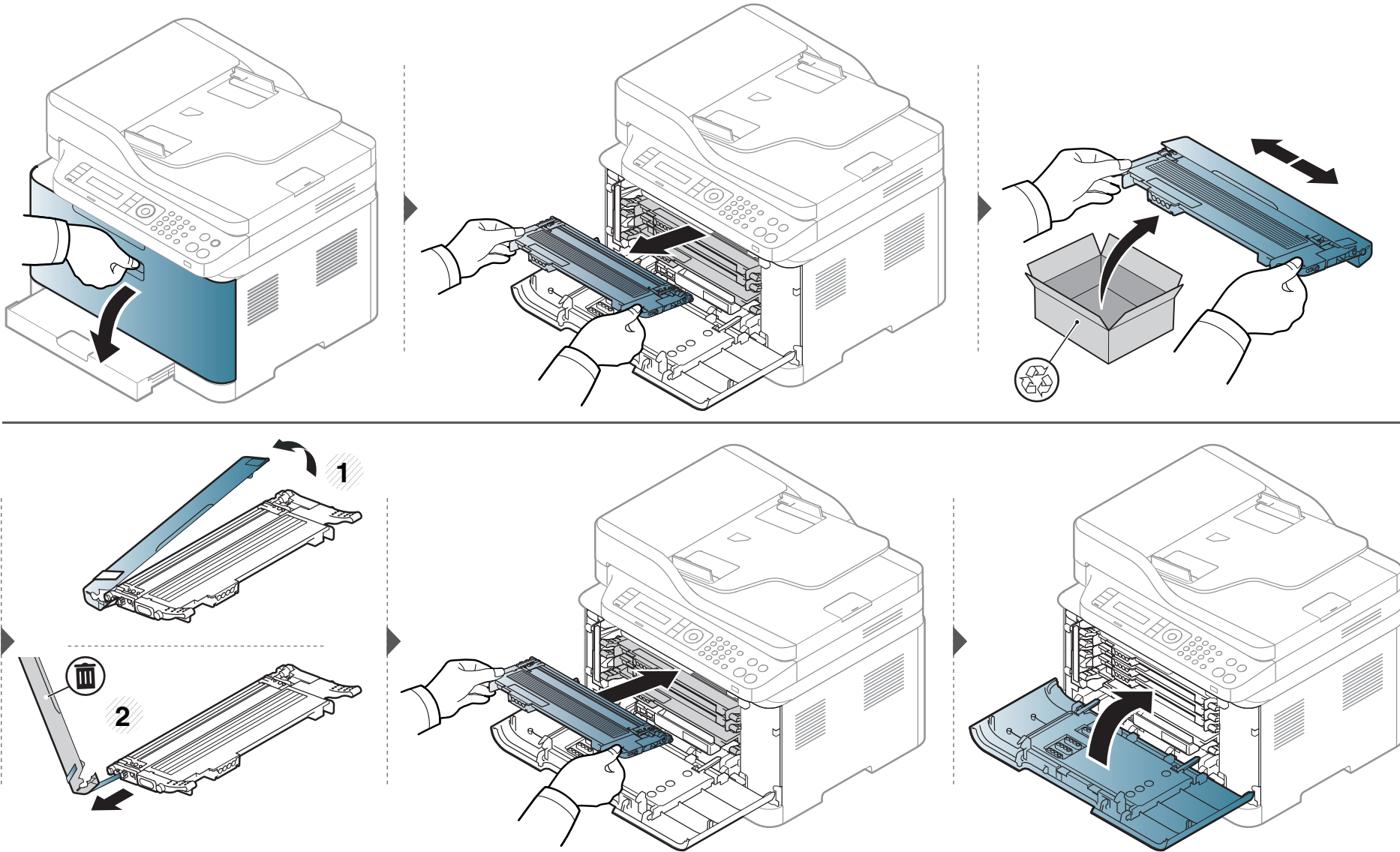

Replacing the imaging unit

When the life span of the imaging unit has expired, the Printing Status window appears on the computer, indicating the imaging unit needs to be placed. Otherwise, your machine stops printing.



- Don't use sharp objects such as a knife or scissors to open the imaging unit package. You could damage the surface of the imaging unit.
- Be careful not to scratch the surface of the imaging unit.
- To prevent damage, do not expose the imaging unit to light for more than a few minutes. Cover it with a piece of paper to protect it if necessary.
- Before closing the front cover, make sure all toner cartridges are installed properly.

Replacing the imaging unit

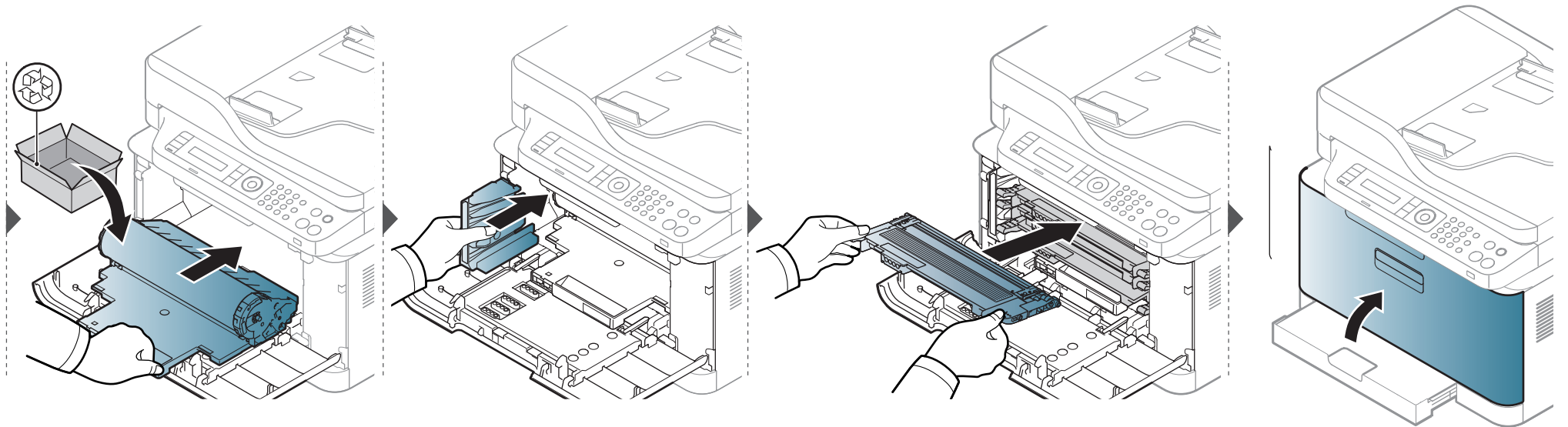
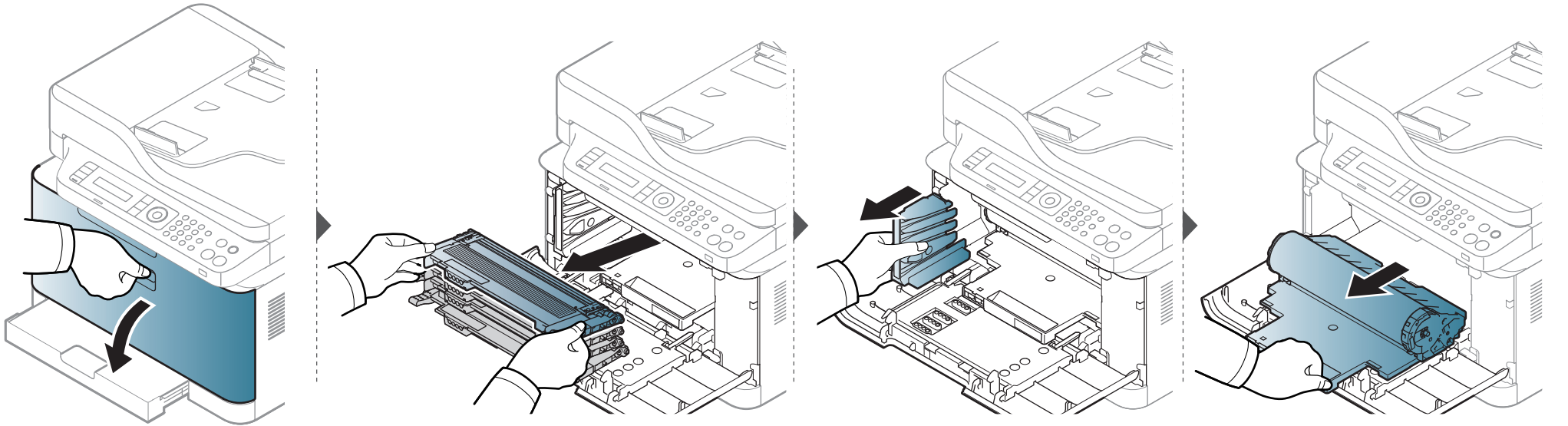

Replacing the waste toner container

When the life span of the waste toner container has expired, waste toner container-related message appears on the screen display of the control panel, indicating the waste toner container needs to be replaced. Check the waste toner container for your machine (see "Available supplies" on page 82). For information about installing the waste toner container, refer to the waste toner container installation guide included on the package.



- Toner particles can be released inside the machine but it does not mean the machine is damaged. Contact a service representative when print quality problems occur.
- When you pull out the waste toner container out of the machine, move the container carefully not to drop it from your hands.
- Make sure that you lay the waste toner container on a flat surface so that the toner does not spill.



Do not tilt or turn over the container.

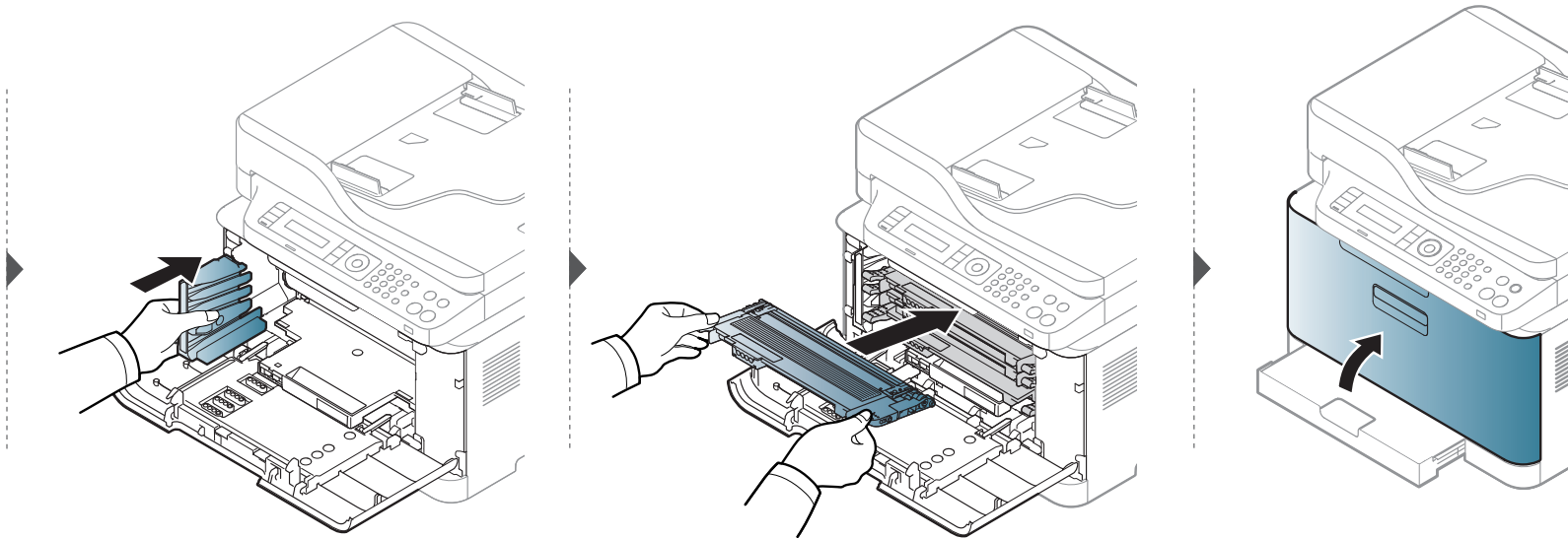
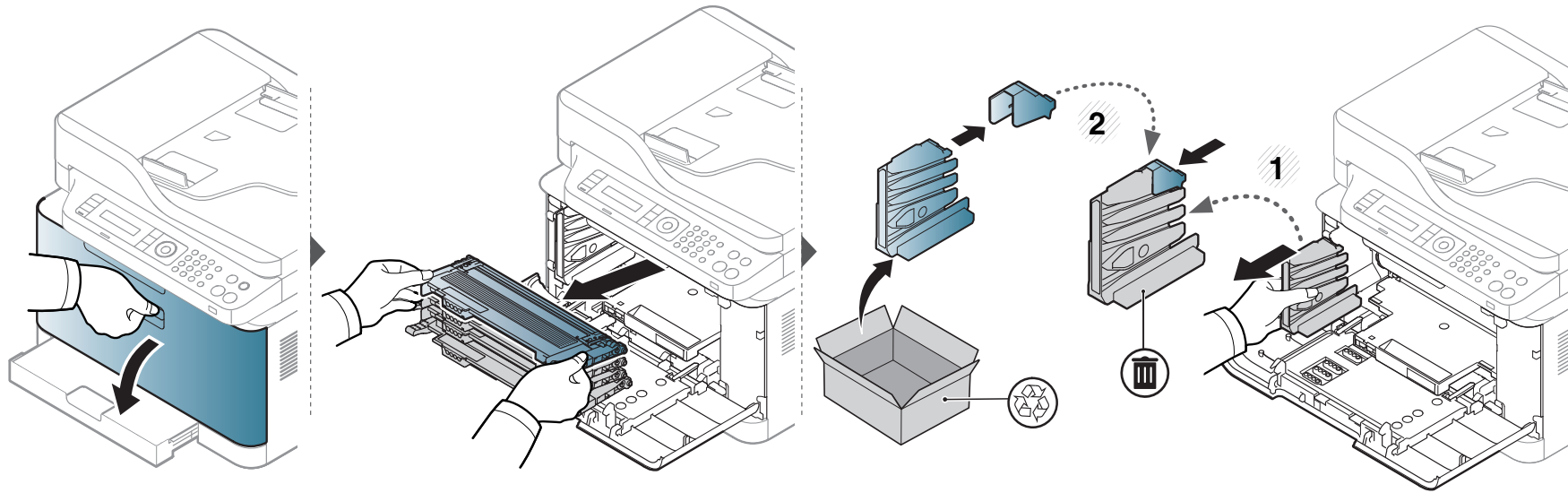

Replacing the waste toner container



Monitoring the supplies life

If you experience frequent paper jams or printing problems, check the number of pages the machine has printed or scanned. Replace the corresponding parts, if necessary.

 It may be necessary to press **OK** to navigate to lower-level menus for some models.

- 1 Select  (**Menu**) > **System Setup** > **Maintenance** > **Supplies Life** on the control panel.
- 2 Select the option you want and press **OK**.
- 3 Press  (**Stop/Clear**) to return to ready mode.

Setting the toner low alert

If the amount of toner in the cartridge is low, a message or LED informing the user to change the toner cartridge appears. You can set the option for whether or not this message or LED appears.



- You change the machine's setting set in the machine from Samsung Easy Printer Manager or SyncThru™ Web Service.
 - If your machine is connected to the local, you can set the machine's setting from **Samsung Easy Printer Manager > Advanced Setting > Device Settings** (see "Using Samsung Easy Printer Manager" on page 268).
 - If your machine is connected to the network, you can set the machine's setting from **SyncThru™ Web Service > Settings tab > Machine Settings** (see "Using SyncThru™ Web Service" on page 265).
- It may be necessary to press **OK** to navigate to lower-level menus for some models.

- 1 Select  **(Menu) > System Setup > Maintenance > TonerLow Alert** on the control panel.
- 2 Select the option you want.
- 3 Press **OK** to save the selection.

Cleaning the machine

If printing quality problems occur or if you use your machine in a dusty environment, you need to clean your machine regularly to keep it in the best printing condition and use your machine longer.



- Cleaning the cabinet of the machine with cleaning materials containing large amounts of alcohol, solvents, or other strong substances can discolor or distort the cabinet.
- If your machine or the surrounding area is contaminated with toner, we recommend you use a cloth or tissue dampened with water to clean it. If you use a vacuum cleaner, toner blows in the air and might be harmful to you.

Cleaning the outside or the display screen

Clean the machine cabinet or the display screen with a soft, lint-free cloth. Dampen the cloth slightly with water, but be careful not to let any water drip onto or into the machine.

Cleaning the machine

Cleaning the inside

During the printing process, paper, toner, and dust particles can accumulate inside the machine. This buildup can cause print quality problems, such as toner specks or smearing. Cleaning the inside of the machine clears and reduces these problems.



- To prevent damage to the imaging unit, do not expose it to light for more than a few minutes. Cover it with a piece of paper, if necessary.
- Do not touch the green area of the imaging unit. Use the handle on the imaging unit to avoid touching this area.
- Use a dry lint free cloth when cleaning the inside of the machine, be careful not to damage the transfer roller or any other inside parts. Do not use solvents such as benzene or thinner. Printing quality problems can occur and cause damage to the machine.



- Use a dry lint-free cloth to clean the machine.
- Turn the machine off and unplug the power cord. Wait for the machine to cool down. If your machine has a power switch, turn the power switch off before cleaning the machine.
- Illustrations on this user's guide may differ from your machine depending on its options or models. Check your machine type (see "Front view" on page 21).
- When opening a scan unit, hold the document feeder and scan unit together.

Cleaning the machine

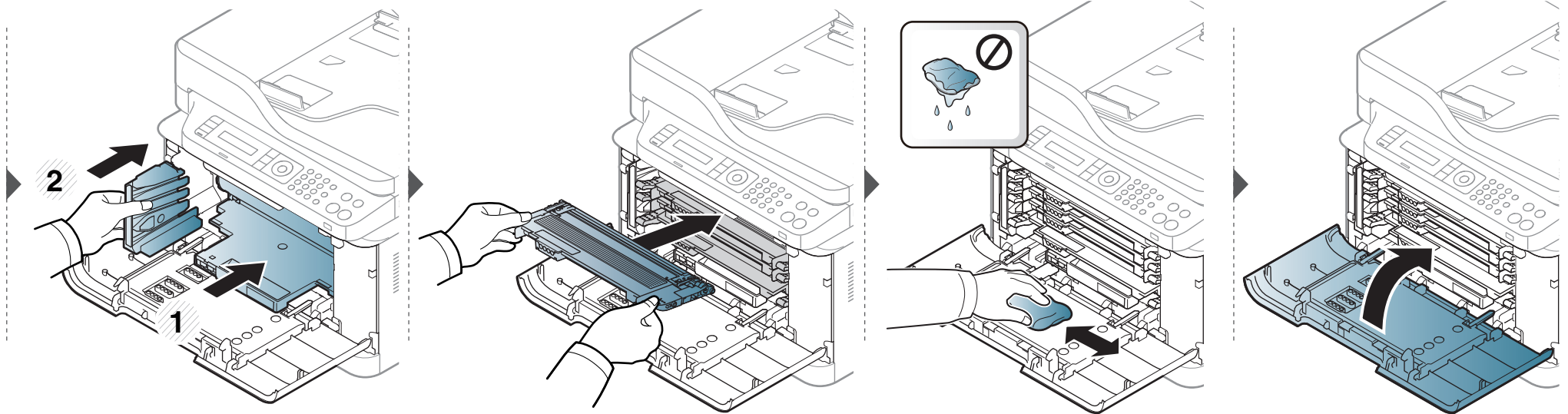
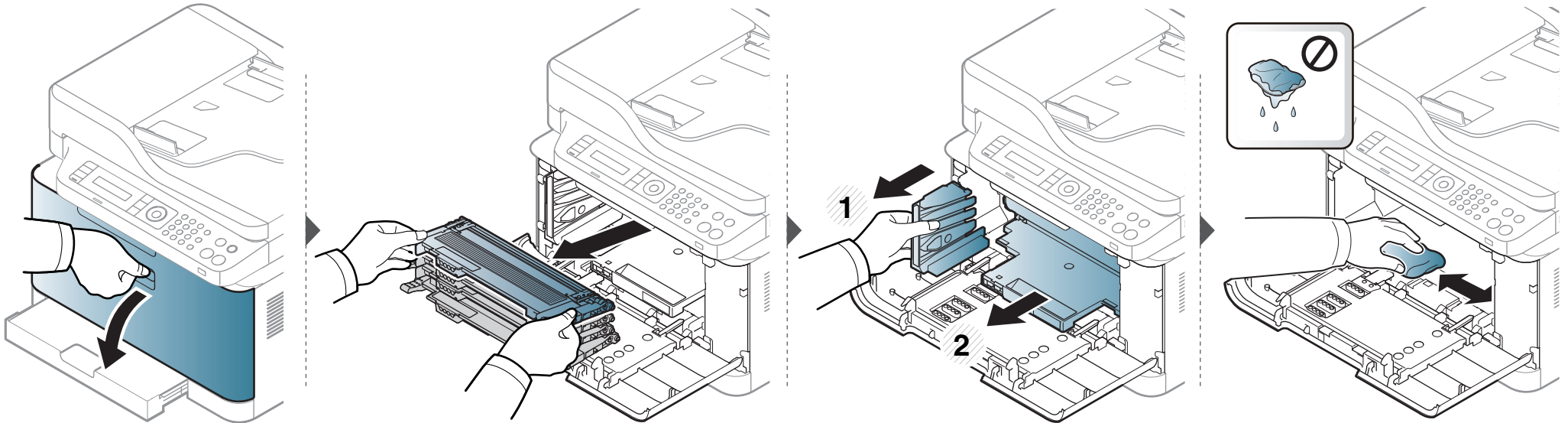

Cleaning the machine

Cleaning the scan unit

Keeping the scan unit clean helps ensure the best possible copies. We suggest that you clean the scan unit at the start of each day and during the day as needed.



- Turn the machine off and unplug the power cord. Wait for the machine to cool down. If your machine has a power switch, turn the power switch off before cleaning the machine.
- Illustrations on this user's guide may differ from your machine depending on its options or models. Check your machine type (see "Front view" on page 21).

- 1 Slightly dampen a soft, lint-free cloth or paper towel with water.
- 2 Lift and open the scanner lid.

- 3 Wipe the surface of the scanner until it is clean and dry.

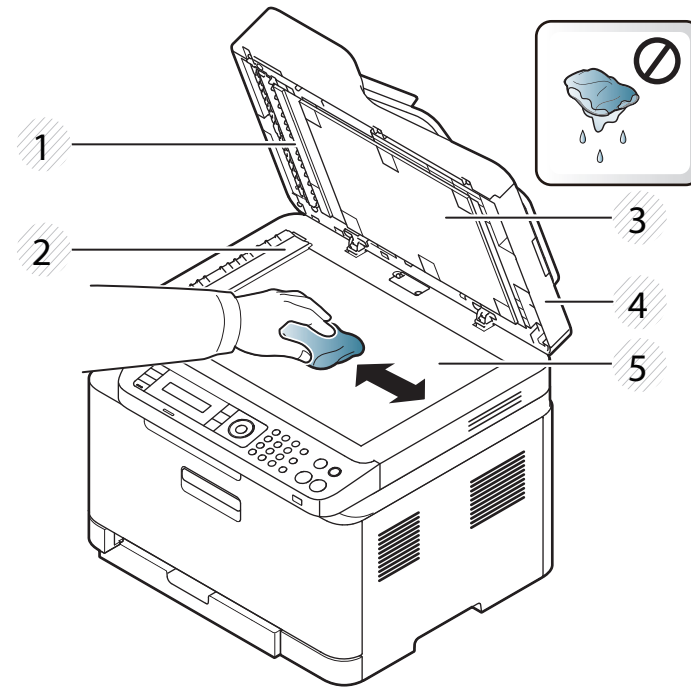

- 1 White bar
- 2 Document feeder glass
- 3 White sheet
- 4 Scanner lid
- 5 Scanner glass

- 4 Close the scanner lid.

Tips for moving & storing your machine

- When moving the machine, do not tilt or turn it upside down. Otherwise, the inside of the machine may be contaminated by toner, which can cause damage to the machine or reduce print quality.
- When moving the machine, make sure at least two people are holding the machine securely.



4. Troubleshooting

This chapter gives helpful information for what to do if you encounter an error.

- **Tips for avoiding paper jams** 107
- **Clearing paper jams** 108
- **Understanding the status LED** 115
- **Understanding display messages** 117



This chapter gives helpful information for what to do if you encounter an error. If your machine has a display screen, check the message on the display screen first to solve the error. If you cannot find a solution to your problem in this chapter, refer to the **Troubleshooting** chapter in the Advanced Guide (see "Troubleshooting" on page 282). If you cannot find a solution in the User's Guide or the problem persists, call for service.

Tips for avoiding paper jams

By selecting the correct medias, most paper jams can be avoided. To avoid paper jams, refer to the following guidelines:

- Ensure that the adjustable guides are positioned correctly (see "Tray overview" on page 41).
- Do not remove paper from the tray while your machine is printing.
- Flex, fan, and straighten paper before loading.
- Do not use creased, damp, or highly curled paper.
- Do not mix papers in a tray.
- Use only recommended print media (see "Print media specifications" on page 127).
- Perforated or embossed paper does not separate easily. Flex the sheets back and forth to loosen them, and fan them.
Feed single paper from tray if there are multi-feeds or paper jams.
- Grain refers to the alignment of the paper fibers in a sheet of paper. Grain long paper is recommended.
- Do not use rough-edged paper.

Clearing paper jams

When an original document jams in the document feeder, a warning message appears on the display.

 To avoid tearing the document, remove the jammed document slowly and carefully.

 To prevent document jams, use the scanner glass for thick, thin or mixed paper- originals.

Clearing paper jams

In tray



Illustrations on this user's guide may differ from your machine depending on its options or models. Check your machine type (see "Front view" on page 21).

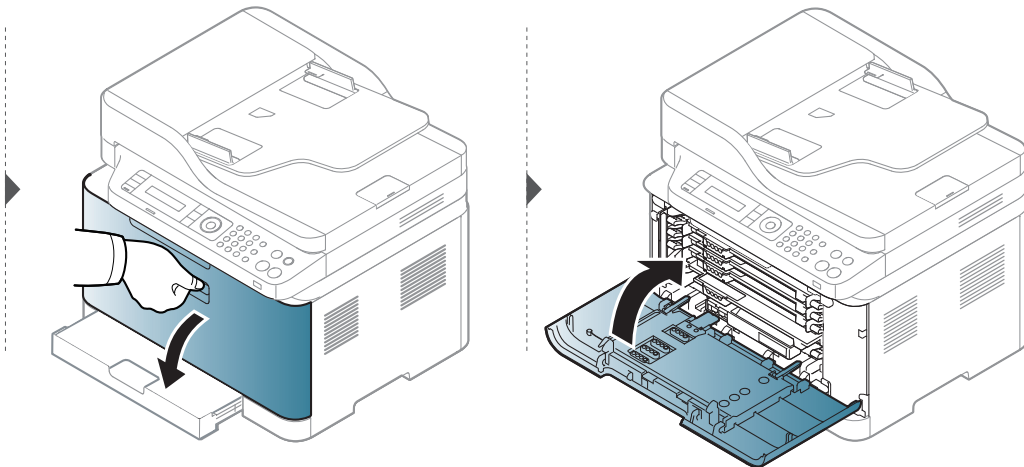
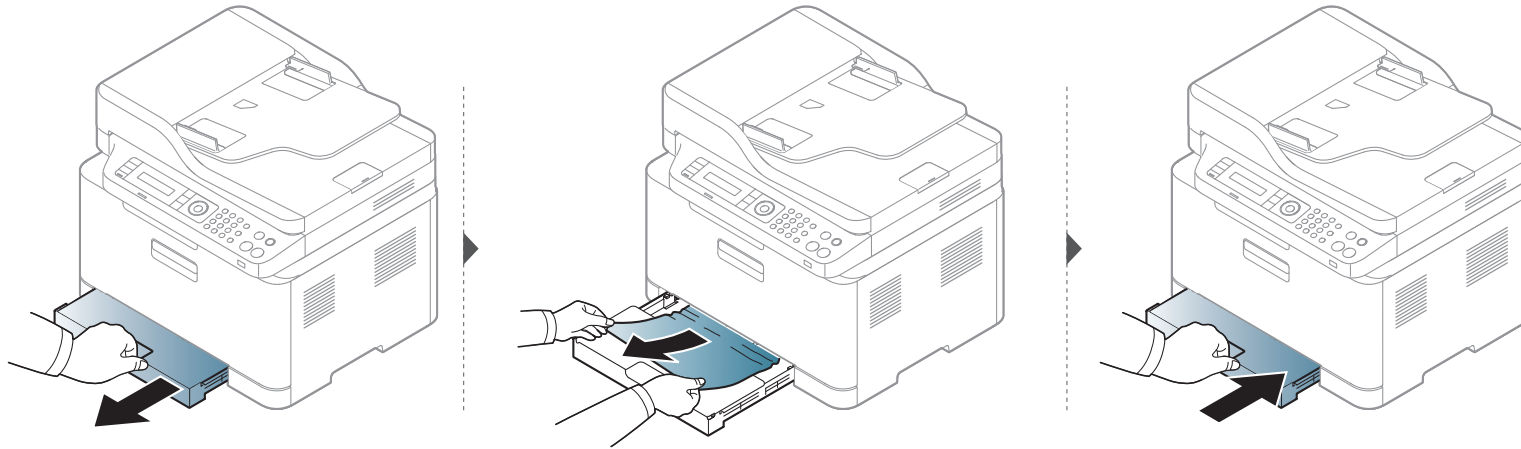

Clearing paper jams

Inside the machine



- The fuser area is hot. Take care when removing paper from the machine.
- Illustrations on this user's guide may differ from your machine depending on its options or models. Check your machine type (see "Front view" on page 21).

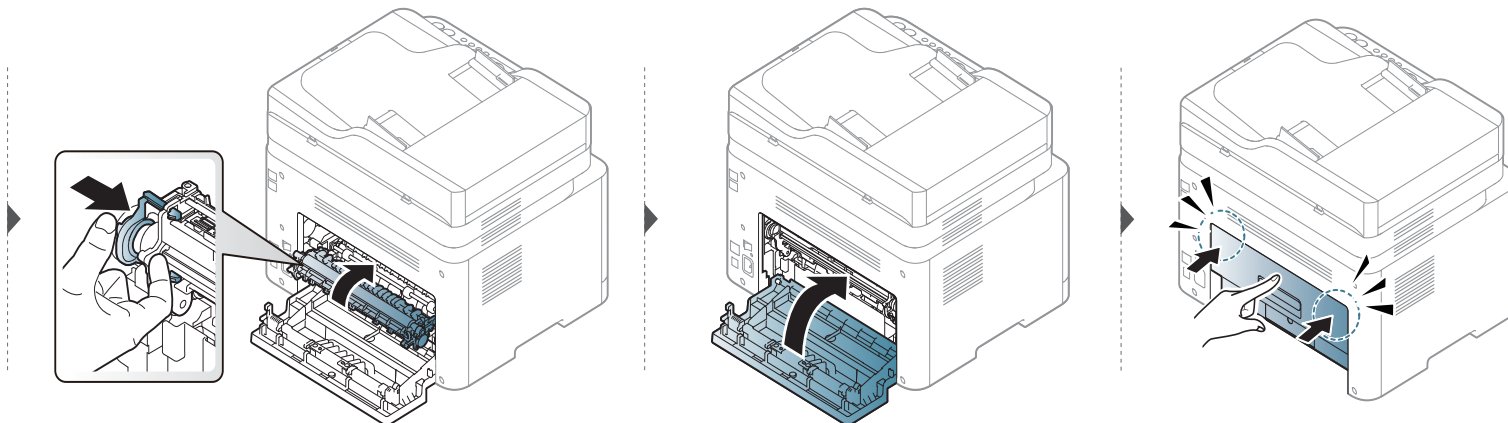
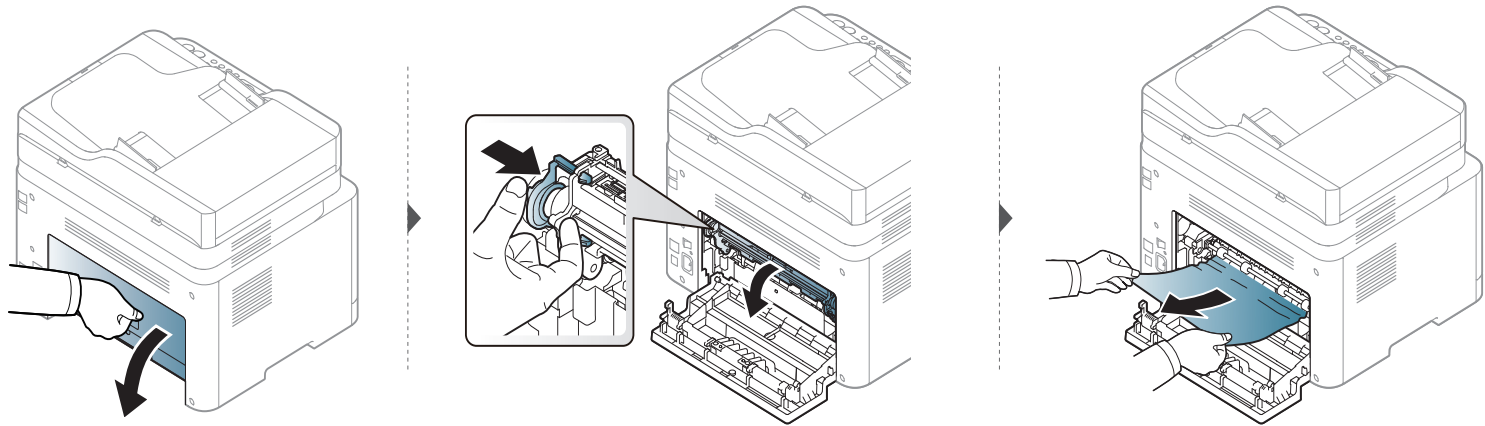

Clearing paper jams

In exit area



- The fuser area is hot. Take care when removing paper from the machine.
- Illustrations on this user's guide may differ from your machine depending on its options or models. Check your machine type (see "Front view" on page 21).

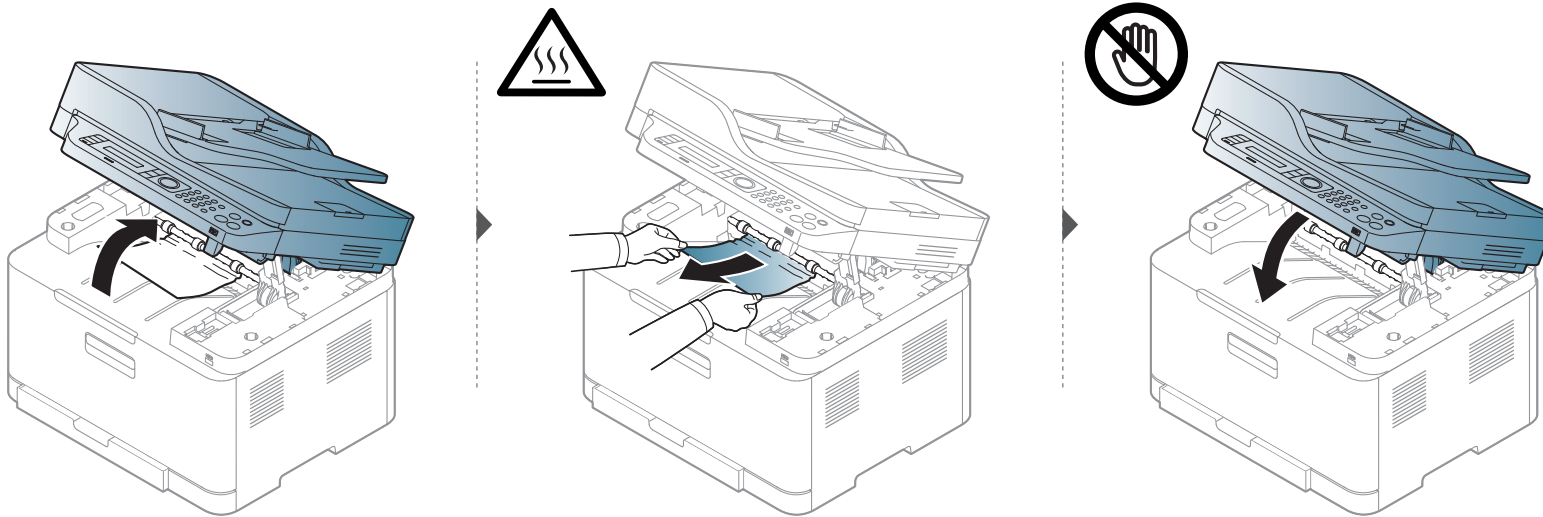

Clearing paper jams

Original paper jam

Original paper jam in front of scanner



- Illustrations on this user's guide may differ from your machine depending on its options or models. Check your machine type (see "Front view" on page 21).
- This troubleshooting may not be available depending on model or optional goods (see "Variety feature" on page 10).

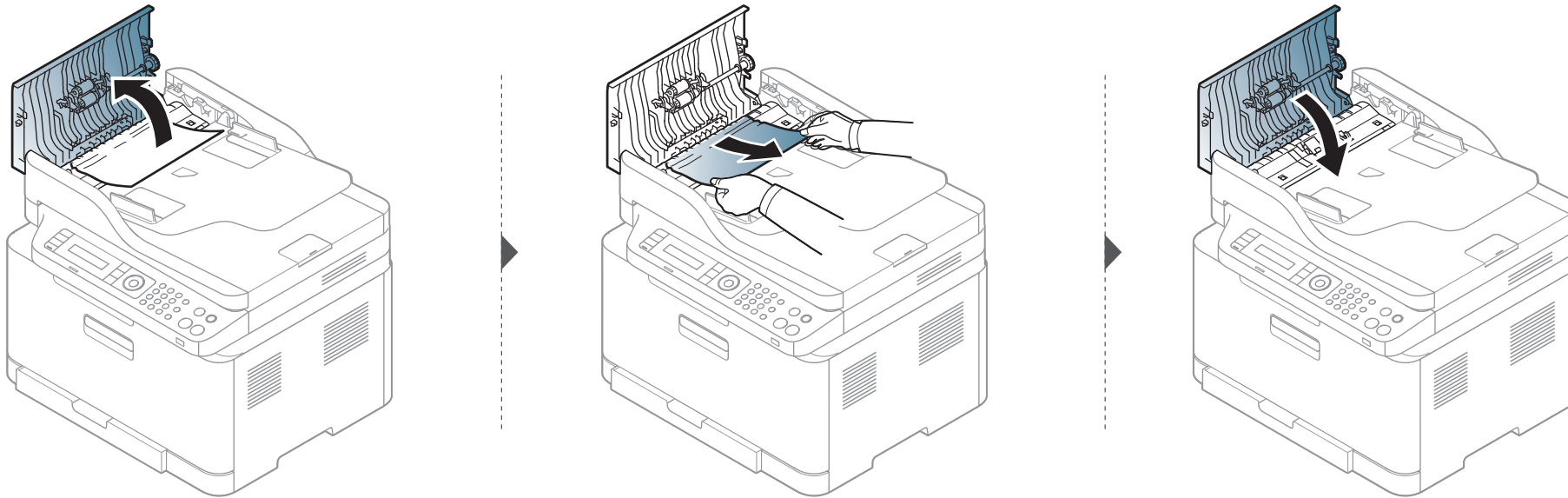

Clearing paper jams

Original paper jam inside of scanner



- Illustrations on this user's guide may differ from your machine depending on its options or models. Check your machine type (see "Front view" on page 21).
- This troubleshooting may not be available depending on model or optional goods (see "Variety feature" on page 10).

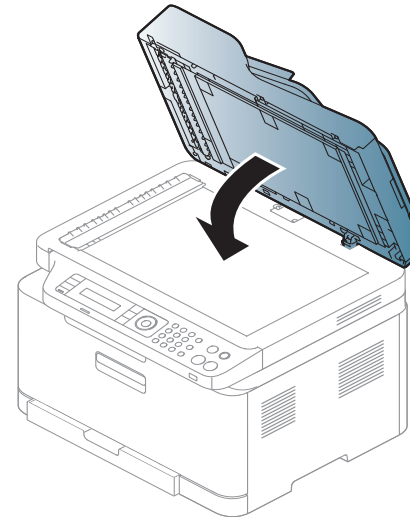
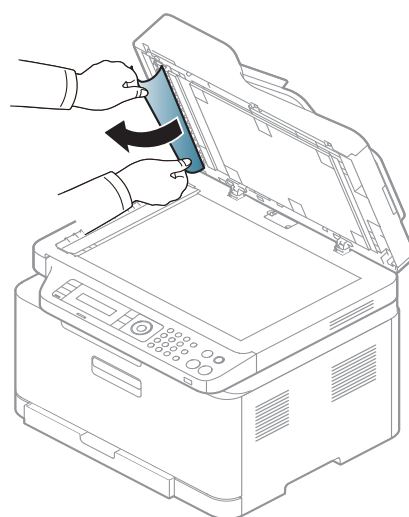
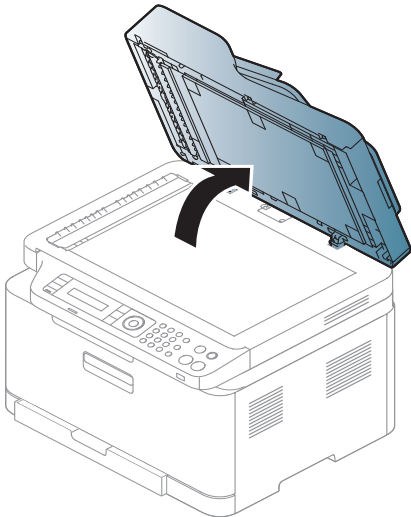
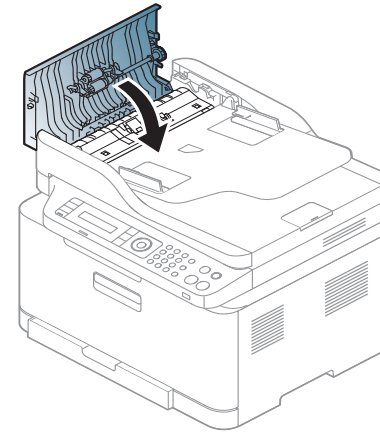
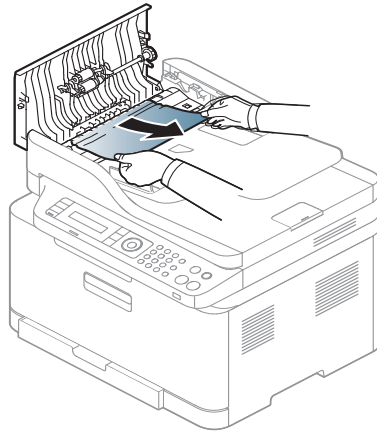
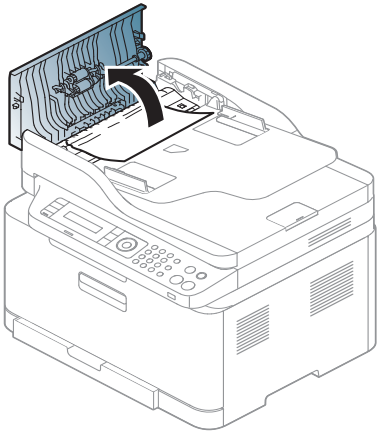

Clearing paper jams

Original paper jam in exit area of scanner



- Illustrations on this user's guide may differ from your machine depending on its options or models. Check your machine type (see "Front view" on page 21).
- This troubleshooting may not be available depending on model or optional goods (see "Front view" on page 21).

- 1 Remove any remaining pages from the document feeder.
- 2 Gently remove the jammed paper from the document feeder.

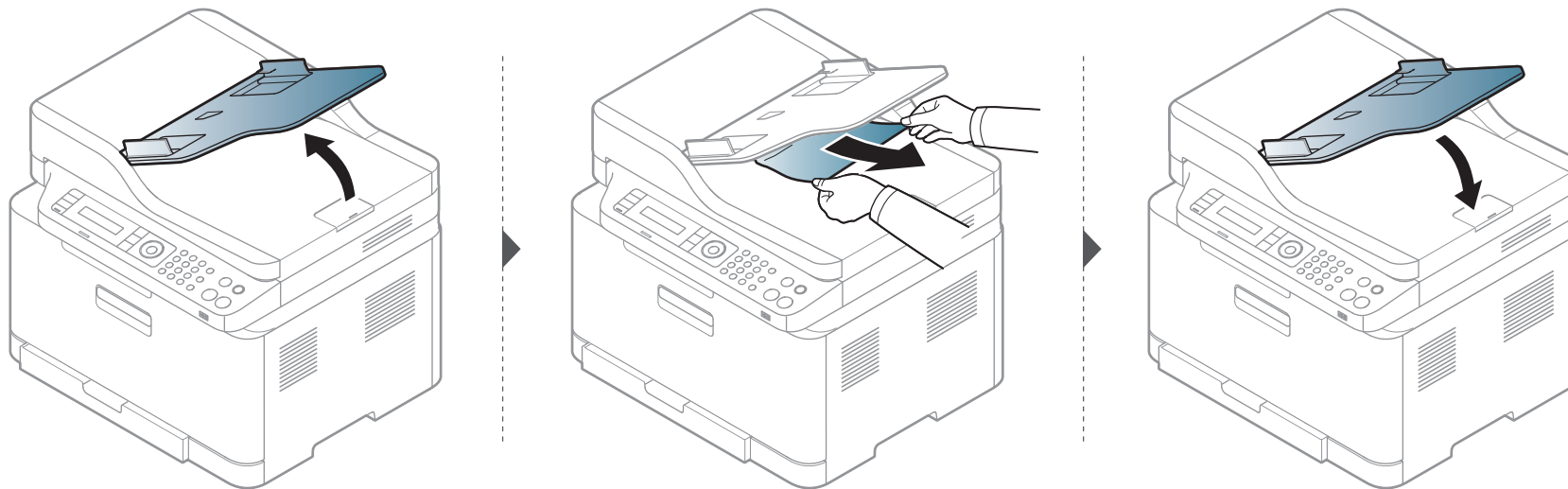

Understanding the status LED

The color of the LED indicates the machine's current status.



- Some LEDs may not be available depending on model or country (see "Control panel overview" on page 24).
- To resolve the error, look at the error message and its instructions from the troubleshooting part (see "Understanding display messages" on page 117).
- You also can resolve the error with the guideline from the computer's Samsung Printing Status window (see "Using Samsung Printer Status" on page 271).
- If the problem persists, call a service representative.

| LED | Status | Description | |
|--------|--------|--------------------------|--|
| Status | Off | The machine is off-line. | |
| | Blue | Blinking | When the backlight blinks, the machine is receiving or printing data. |
| | | On | <ul style="list-style-type: none">• The machine is on-line and can be used. |
| | Orange | Blinking | <ul style="list-style-type: none">• A minor error has occurred and the machine is waiting for the error to be cleared. Check the display message. When the problem is cleared, the machine resumes.• Small amount of toner is left in the cartridge. The estimated cartridge life^a of toner is close. Prepare a new cartridge for replacement. You may temporarily increase the printing quality by redistributing the toner (see "Redistributing toner" on page 85).^b |
| | | On | <ul style="list-style-type: none">• A toner cartridge has almost reached its estimated cartridge life^a. It is recommended to replace the toner cartridge (see "Replacing the toner cartridge" on page 87).• The cover is opened. Close the cover.• There is no paper in the tray when receiving or printing data. Load paper in the tray.• The machine has stopped due to a major error. Check the display message (see "Understanding display messages" on page 117).• A paper jam has occurred (see "Clearing paper jams" on page 108). |

Understanding the status LED

| LED | Status | | Description |
|---|--------|----------|--|
| Wireless ^b | Blue | Blinking | The machine is connecting to a wireless network. |
| | | On | The machine is connected to a wireless network (see "Wireless network setup" on page 168). |
| | | Off | The machine is disconnected from a wireless network. |
| Power/Wake Up () | Blue | On | The machine is in power save mode. |
| | | Off | The machine is in ready mode or machine's power is off. |
| Eco | Green | On | Eco mode is on. The default setting of Eco mode is 2-up and toner save. |
| | | Off | Eco mode is off. |
| Scan to ^b | Blue | On | Scan mode is on. Switches between scan and copy mode. The Scan to LED turns on scan mode and turns off on copy mode. |
| | | Off | Scan mode is off and copy mode is on. |

a. Estimated cartridge life means the expected or estimated toner cartridge life, which indicates the average capacity of print-outs and is designed pursuant to ISO/IEC 19798. The number of pages may be affected by operating environment, percentage of image area, printing interval, graphics, media and media size. Some amount of toner may remain in the cartridge even when red LED is on and the printer stops printing.

b. Some LEDs may not be available depending on model or country (see "Control panel overview" on page 24).

Understanding display messages

Messages appear on the control panel display to indicate the machine's status or errors. Refer to the tables below to understand the messages' and their meaning, and correct the problem, if necessary.



- This function is not supported for the devices which has a control panel display. You can resolve the error with the guideline from the computer's Printing Status window (see "Using Samsung Printer Status" on page 271).
- If a message is not in the table, reboot the power and try the printing job again. If the problem persists, call a service representative.
- When you call for service, provide the service representative with the contents of display message.
- Some messages may not appear on the display depending on the options or models.
- [error number] indicates the error number.
- [tray type] indicates the tray number.
- [media type] indicates the media type.
- [media size] indicates the media size.
- [color] indicates the color of toner.

Paper Jam-related messages

| Message | Meaning | Suggested solutions |
|-------------------------------------|---|---|
| Document jam. Remove jam | The loaded original document has jammed in the document feeder. | Clear the jam (see "Original paper jam" on page 112). |
| Paper Jam inside machine | Paper has jammed inside the machine. | Clear the jam (see "Inside the machine" on page 110). |
| Paper Jam in tray | Paper has jammed in the paper tray. | Clear the jam (see "Clearing paper jams" on page 108). |
| Paper Jam in exit area | Paper has jammed in the exit area. | Clear the jam (see "Original paper jam in exit area of scanner" on page 114). |
| Paper Empty in tray | There is no paper in tray. | Load paper in tray (see "Loading paper in the tray" on page 42). |

Understanding display messages

Toner-related messages

| Message | Meaning | Suggested solutions |
|-------------------------------------|---|---|
| Install Toner | A toner cartridge is not installed. | Install a toner cartridge. |
| Not Compatible [color] toner | The toner cartridge is not suitable for your machine. | Install the corresponding toner cartridge with a Samsung-genuine cartridge. |
| Prepare Toner | Small amount of toner is left in the indicated cartridge. The estimated cartridge life of toner is close. | Prepare a new cartridge for a replacement. You may temporarily increase the printing quality by redistributing the toner (see "Redistributing toner" on page 85). |

| Message | Meaning | Suggested solutions |
|----------------------|---|---|
| Replace Toner | The indicated toner cartridge has almost reached its estimated cartridge life. ^a | <ul style="list-style-type: none">You can choose Stop or Continue as shown on the control panel. If you select Stop, the printer stops printing and you cannot print any more without changing the cartridge. If you select Continue, the printer keeps printing but the printing quality cannot be guaranteed. Besides, it can cause serious damage to your machine.Replace the toner cartridge for the best print quality when this message appears. Using a cartridge beyond this stage can result in printing quality issues (see "Replacing the toner cartridge" on page 87). |
| | The indicated toner cartridge has reached its estimated cartridge life. ^a The machine might stop printing. | Replace the toner cartridge (see "Replacing the toner cartridge" on page 87). |

a. Estimated cartridge life means the expected or estimated toner cartridge life, which indicates the average capacity of print-outs and is designed pursuant to ISO/IEC 19798 (see "Available supplies" on page 82). The number of pages may be affected by operating environment, percentage of image area, printing interval, media, percentage of image area, and media size. Some amount of toner may remain in the cartridge even when replace new cartridge appears and the machine stops printing.



Samsung does not recommend using a non-genuine Samsung toner cartridge such as refilled or remanufactured. Samsung cannot guarantee a non-genuine Samsung toner cartridge's quality. Service or repair required as a result of using non-genuine Samsung toner cartridges will not be covered under the machine warranty.

Understanding display messages

Tray-related messages

| Message | Meaning | Suggested solutions |
|----------------------------|--|-------------------------------------|
| Tray Paper Mismatch | The paper size specified in the printer properties does not match the paper you are loading. | Load the correct paper in the tray. |

Network-related messages

| Message | Meaning | Suggested solutions |
|-------------------------------|--|--|
| Fail connection to WPS | The machine failed to connect via WPS. | Check the WPS settings (see "Using the WPS Settings menu" on page 169). |
| Install wireless NIC | There is a problem on the network interface. | Turn the power switch off and on. If the problem persists, call for service. |

| Message | Meaning | Suggested solutions |
|-------------------------------------|--|--|
| Network Problem: IP Conflict | The network IP address you have set is being used by someone else. | Check the IP address and reset it if necessary (see "Printing a network configuration report" on page 157). |
| Not found Wireless network | The machine cannot find the wireless network. | Check the status of the wireless router or access point, including its configuration and power connections, as well as any devices that may affect wireless communication. If the problem persists, please call for service. |

Understanding display messages

| Message | Meaning | Suggested solutions |
|---|--|---|
| Not Correct Wireless setting | <ul style="list-style-type: none"> The wireless network options are configured incorrectly for the security method. The password entered in the wireless security options is incorrect. The machine does not support the security method used by the access point or wireless router. The access point or wireless router has malfunctioned. | Reconfigure the wireless options in the machine, SWS, access point, or wireless router. The WPA2-PSK/AES security method is recommended. If the problem persists, please call for service. |
| Not connect Wireless AP | The machine failed to connect to the wireless AP(access point or wireless router). | Check the status of the access point, including its configuration and power connections, as well as any devices that may affect wireless communication. If the problem persists, please call for service. |

| Message | Meaning | Suggested solutions |
|--|---|--|
| Wi-Fi Direct is not ready | The machine failed to initialize the Wi-Fi Direct connection. | Reboot the machine to initialize the wireless settings. If the problem persists, please call for service. |
| Wi-Fi Direct is not connect | The machine failed to connect via Wi-Fi Direct. | Turn the Wi-Fi Direct feature off and then back on or reboot the machine or mobile device. If the problem persists, please call for service. |

Misc. messages

| Message | Meaning | Suggested solutions |
|---|---|---|
| Door Open Close it | The cover is not securely latched. | Close the cover until it locks into place. |
| Door of scanner is open | The cover of scanner is not securely latched. | Close the cover until it locks into place. |
| Error: [error number] Call for Service | There is a problem in the system. | Reboot the power. If the problem persists, please call for service. |

Understanding display messages

| Message | Meaning | Suggested solutions |
|---|---|--|
| Error: [error number] Door open/close | The imaging unit is installed improperly, or the cover is not securely latched. | Reinstall the imaging unit to confirm it is seated properly. Close the cover until it locks into place. |
| Error: [error number] Turn off then on | The machine unit cannot be controlled. | Reboot the power and try the printing job again. If the problem persists, please call for service. |
| ID Control Fail Check CTD Sensor | There is a problem in the CTD sensor. | Reboot the power. If the problem persists, please call for service. |
| Output bin Full Remove paper | The output tray is full. Or the sensor is not facing down. | Remove papers from the output tray, the machine resumes printing. Or make sure the sensor is facing down. If the problem persists, call for service. |
| Prepare Fuser Soon | The life of the fuser unit will be expired soon. | Prepare the fuser unit with a new one. Contact the service representatives. |
| Prepare new Imaging unit | The life of the imaging unit will be expired soon. | Replace the imaging unit with a new one. Contact the service representatives. |

| Message | Meaning | Suggested solutions |
|--------------------------------------|--|--|
| Prepare new Transfer belt | The life of the transfer belt will expired soon. | Replace the transfer belt with a new one. Contact the service representatives. |
| Prepare new transfer roller | The life of the transfer belt will expired soon. | Replace the transfer belt with a new one. Contact the service representatives. |
| Replace new Fuser unit | The life of the fuser unit will be expired. | Replace the fuser unit with a new one. Contact the service representatives. |
| Replace with new imaging unit | The life of the imaging unit will be expired. | Replace the imaging unit with a new one. Contact the service representatives. |
| Replace new Transfer belt | The life of the transfer belt has expired. | Replace the transfer belt with a new one. Contact the service representatives. |
| Replace new transfer roller | The life of the transfer belt has expired. | Replace the transfer belt with a new one. Contact the service representatives. |

Understanding display messages

| Message | Meaning | Suggested solutions |
|---|---|--|
| Replace/Install Waste Toner Tank | The life span of the waste toner container has expired and the printer will stop printing until a new waste toner container is placed into the printer. | Replace a waste toner container with a Samsung-genuine waste toner container. |
| Scanner Locked | The scanner is locked. | Reboot the power. If the problem persists, please call for service. |
| Scan Unit Open or Exit JAM | The scan unit is not securely latched or paper has jammed in the scanner area. | <ul style="list-style-type: none">• Clear the jam (see "Original paper jam" on page 112).• Close the cover until it locks into place. |
| Transfer Belt Error | The transfer belt cannot be controlled. | Reboot the power and try the printing job again. If the problem persists, please call for service. |



5. Appendix

This chapter provides product specifications and information concerning applicable regulations.

- **Specifications** 125
- **Regulatory information** 134
- **Copyright** 147



Specifications

General specifications



These specifications are subject to change without notice. To see additional specifications and information about changes to the specifications, please visit www.samsung.com.

| Items | | Description | |
|---------------------------------|---------------------------------|---------------------------|--|
| Dimension^a | Width x Length x Height | C48x/C48xW series | 406 x 362 x 288.6 mm (16 x 14.3 x 11.4 inches) |
| | | C48xFN/C48xFW series | 406 x 362 x 333.5 mm (16 x 14.3 x 13.1 inches) |
| Weight^a | Machine with consumables | C48x/C48xW series | 12.89 Kg (28.42 lbs) |
| | | C48xFN/C48xFW series | 14.06 Kg (31.00 lbs) |
| Noise Level^{bc} | Ready mode | Background noise level | |
| | Print mode | Color printing | Less than 46 dB (A) |
| | | Black and white printing | Less than 48 dB (A) |
| | Copy mode | Scanner glass | Less than 52 dB (A) |
| | | Document feeder | Less than 53 dB (A) |
| | Scan mode | Scanner glass | Less than 51 dB (A) |
| Document feeder | | Less than 51 dB (A) | |
| Temperature | Operation | 10 to 30°C (50 to 86°F) | |
| | Storage (packed) | -20 to 40°C (-4 to 104°F) | |

Specifications

| | Items | Description |
|--------------------------------------|---|---|
| Humidity | Operation | 20 to 80% RH |
| | Storage (packed) | 10 to 90% RH |
| Power rating^d | 110 volt models | AC 110 - 127 V |
| | 220 volt models | AC 220 - 240 V |
| Power consumption^e | Average operating mode | Less than 290 W |
| | Ready mode | Less than 60 W |
| | Power save mode | <ul style="list-style-type: none"> • C48x: Less than 1.2 W • C48xW: Less than 1.5 W • C48xFN: Less than 1.5 W • C48xFW: Less than 1.8 W |
| | Power off mode^f | Less than 0.45 W |
| | Network Standby Mode (All Port Activation) | <ul style="list-style-type: none"> • C48xW/C48xFW: Less than 1.30 W |
| Wireless^g | Module | SPW-B43143S |

a. Dimensions and weight are measured without other accessories.

b. Sound Pressure Level, ISO 7779. Configuration tested: basic machine installation, A4 paper, simplex printing.

c. China only: If the equipment's noise is louder than 63 db (A), the equipment should be placed in region of relatively independent advice.

d. See the rating label on the machine for the correct voltage (V), frequency (hertz) and of current (A) for your machine.

e. The power consumption may be affected by the machine's status, setting conditions, operating environment, and measuring equipment and method the country uses.

f. Power consumption can be completely avoided only when the power cable is not connected.

g. Wireless models only (see "Features by model" on page 7).

Specifications

Print media specifications

| Type | Size | Dimensions | Print media weight/Capacity ^a |
|--------------------|---|------------------------------------|--|
| | | | Tray |
| Plain paper | Letter | 216 x 279 mm (8.5 x 11 inches) | 60 to 85 g/m ² (16 to 23 lbs bond) |
| | Legal | 216 x 356 mm (8.5 x 14 inches) | <ul style="list-style-type: none"> 150 sheets of 75 g/m² (20 lbs bond) Maximum stack height : 15.5mm (0.6 inches) |
| | US Folio | 216 x 330 mm (8.5 x 13 inches) | |
| | A4 | 210 x 297 mm (8.27 x 11.69 inches) | |
| | Oficio | 216 x 343 mm (8.5 x 13.5 inches) | |
| | JIS B5 | 182 x 257 mm (7.17 x 10.12 inches) | |
| | ISO B5 | 176 x 250 mm (6.93 x 9.84 inches) | |
| | Executive | 184 x 267 mm (7.25 x 10.5 inches) | |
| | A5 | 148 x 210 mm (5.83 x 8.27 inches) | |
| | A6 | 105 x 148 mm (4.13 x 5.83 inches) | |
| Thick paper | Refer to the Plain paper section | Refer to the Plain paper section | 86 to 120 g/m ² (23 to 32lbs bond) <ul style="list-style-type: none"> 5 sheets |
| Thin paper | Refer to the Plain paper section | Refer to the Plain paper section | 60 to 70 g/m ² (16 to 19 lbs bond) <ul style="list-style-type: none"> 150 sheets of 60 g/m² (16 lbs bond) Maximum stack height : 15.5mm (0.6 inches) |

Specifications

| Type | Size | Dimensions | Print media weight/Capacity ^a |
|------------------------------|---|----------------------------------|---|
| | | | Tray |
| Cotton | Refer to the Plain paper section | Refer to the Plain paper section | 75 to 90 g/m ² (20 to 24 lbs bond) <ul style="list-style-type: none"> 150 sheets of 75 g/m² (20 lbs bond) |
| Colored, Pre-printed, | Refer to the Plain paper section | Refer to the Plain paper section | 60 to 85 g/m ² (16 to 24 lbs bond) <ul style="list-style-type: none"> 150 sheets of 75 g/m² (20 lbs bond) Maximum stack height : 15.5mm (0.6 inches) |
| Recycled | Refer to the Plain paper section | Refer to the Plain paper section | 60 to 85 g/m ² (16 to 24 lbs bond) <ul style="list-style-type: none"> 150 sheets of 75 g/m² (20 lbs bond) Maximum stack height : 15.5mm (0.6 inches) |
| Labels^b | Letter, Legal, Oficio, US Folio, A4, JIS B5, ISO B5, Executive, A5 | Refer to the Plain paper section | 120 to 150 g/m ² (32 to 40 lbs bond) <ul style="list-style-type: none"> 5 sheets |
| Card stock | Letter, Legal, Oficio, US Folio, A4, JIS B5, ISO B5, Executive, A5, Postcard 4x6 | Refer to the Plain paper section | 121 to 163 g/m ² (32 to 43 lbs bond) <ul style="list-style-type: none"> 5 sheets |
| Bond paper | Refer to the Plain paper section | Refer to the Plain paper section | 105 to 120 g/m ² (28 to 32 lbs bond) <ul style="list-style-type: none"> 10 sheets |

Specifications

| Type | Size | Dimensions | Print media weight/Capacity ^a |
|----------------------------------|---|-------------------------------------|--|
| | | | Tray |
| Archive | Refer to the Plain paper section | Refer to the Plain paper section | 70 to 90 g/m ² (18.6 to 24 lbs bond) <ul style="list-style-type: none"> • 100 sheets • Maximum stack height : 15.5mm (0.6 inches) |
| Glossy Photo, Matte Photo | Letter, A4, Postcard 4x6 | Refer to the Plain paper section | 111 to 220 g/m ² (30 to 58 lbs bond) <ul style="list-style-type: none"> • 1 sheets |
| Minimum size (custom) | | 105 x 148.5 mm (4.13 x 5.85 inches) | 60 to 120 g/m ² (16 to 32 lbs bond) |
| Maximum size (custom) | | 216 x 356 mm (8.5 x 14 inches) | |

a. Maximum capacity may differ depending on media weight, thickness, and environmental conditions.

b. The smoothness of the labels used in this machine is 100 to 250 (sheffield). This means the numeric level of smoothness.

 If media weight is over 120 g/m² (32 lbs bond), load a paper into the tray one by one.

Specifications

System requirements

Microsoft® Windows®

| Operating system | Requirement (recommended) | | |
|-----------------------------------|--|---------------|----------------|
| | CPU | RAM | free HDD space |
| Windows® XP Service Pack 3 | Intel® Pentium® III 1 GHz (Pentium IV 2 GHz) | 512 MB (1 GB) | 1.5 GB |
| Windows Server® 2003 | Intel® Pentium® III 1 GHz (Pentium IV 2 GHz) | 512 MB (1 GB) | 1.5 GB |
| Windows Server® 2008 | Intel® Pentium® IV 1 GHz (Pentium IV 2 GHz) | 512 MB (2 GB) | 10 GB |
| Windows Vista® | Intel® Pentium® IV 3 GHz | 512 MB (1 GB) | 15 GB |
| Windows® 7 | Intel® Pentium® IV 1 GHz 32-bit or 64-bit processor or higher | 1 GB (2 GB) | 16 GB |
| | <ul style="list-style-type: none">• Support for DirectX® 9 graphics with 128 MB memory (to enable the Aero theme).• DVD-R/W Drive | | |
| Windows Server® 2008 R2 | Intel® Pentium® IV 1 GHz (x86) or 1.4 GHz (x64) processors (2 GHz or faster) | 512 MB (2 GB) | 10 GB |
| Windows® 8 | Intel® Pentium® IV 1 GHz 32-bit or 64-bit processor or higher | 2 GB (2 GB) | 20 GB |
| Windows® 8.1 | <ul style="list-style-type: none">• Support for DirectX® 9 graphics with 128 MB memory (to enable the Aero theme).• DVD-R/W Drive | | |
| Windows® 10 | | | |
| Windows Server® 2016 | | | |

Specifications

| Operating system | Requirement (recommended) | | |
|---|---|---------------|----------------|
| | CPU | RAM | free HDD space |
| Windows Server® 2012 Windows Server® 2012 R2 | Intel® Pentium® IV 1.4 GHz (x64) processors (2 GHz or faster) | 512 MB (2 GB) | 32 GB |



- Internet Explorer 6.0 or higher is the minimum requirement for all Windows operating systems.
- Users who have administrator rights can install the software.
- **Windows Terminal Services** is compatible with your machine.

Mac

| Operating system | Requirements (Recommended) | | |
|------------------------------|---|-------------|----------------|
| | CPU | RAM | Free HDD space |
| Mac OS X 10.6 | <ul style="list-style-type: none">• Intel® processors | 1 GB (2 GB) | 1 GB |
| Mac OS X 10.7 - 10.10 | <ul style="list-style-type: none">• Intel® processors | 2 GB | 4 GB |

Specifications

Linux

| Items | Requirements |
|-------------------------|--|
| Operating system | Red Hat Enterprise Linux 5, 6, 7 Fedora 11, 12, 13, 14, 15, 16, 17, 18, 19, 20 OpenSUSE 11.2, 11.3, 11.4, 12.1, 12.2, 12.3, 13.1 Ubuntu 10.04, 10.10, 11.04, 11.10, 12.04, 12.10, 13.04, 13.10, 14.04 SUSE Linux Enterprise Desktop 10, 11 Debian 6.0, 7.0 Mint 13, 14, 15, 16, 17 |
| CPU | Pentium IV 2.4GHz (Intel Core™2) |
| RAM | 512 MB (1 GB) |
| Free HDD space | 1 GB (2 GB) |

Specifications

Network environment



Network and wireless models only (see "Features by model" on page 7).

You need to set up the network protocols on the machine to use it as your network machine. The following table shows the network environments supported by the machine.

| Items | Specifications |
|---------------------------------|--|
| Network interface | <ul style="list-style-type: none">• Ethernet 10/100 Base-TX Wired Lan• 802.11b/g/n Wireless LAN |
| Network operating system | <ul style="list-style-type: none">• Windows® XP Service Pack 3, Windows Server® 2003, Windows Vista®, Windows® 7/8, Windows Server® 2008 R2• Various Linux OS• Mac OS X 10.6 -10.10 |
| Network protocols | <ul style="list-style-type: none">• TCP/IPv4• DHCP, BOOTP• DNS, WINS, Bonjour, SLP, UPnP• Standard TCP/IP Printing (RAW), LPR, IPP, WSD• SNMPv 1/2/3, HTTP• TCP/IPv6 (DHCP, DNS, RAW, LPR, SNMPv 1/2/3, HTTP) |
| Wireless security | <ul style="list-style-type: none">• Authentication: Open System, Shared Key, WPA Personal, WPA2 Personal (PSK)• Encryption: WEP64, WEP128, TKIP, AES |

Regulatory information

This machine is designed for a normal work environment and certified with several regulatory statements.

Laser safety statement

The printer is certified in the U.S. to conform to the requirements of DHHS 21 CFR, chapter 1 Subchapter J for Class I(1) laser products, and elsewhere is certified as a Class I laser product conforming to the requirements of IEC 60825-1 : 2007.

Class I laser products are not considered to be hazardous. The laser system and printer are designed so there is never any human access to laser radiation above a Class I level during normal operation, user maintenance or prescribed service condition.

Warning

Never operate or service the printer with the protective cover removed from laser/scanner assembly. The reflected beam, although invisible, can damage your eyes.

When using this product, these basic safety precautions should always be followed to reduce risk of fire, electric shock, and injury to persons:



CAUTION - CLASS 3B. INVISIBLE LASER RADIATION WHEN OPEN. AVOID EXPOSURE TO THE BEAM.

ATTENTION - CLASSE 3B. RADIATION LASER INVISIBLE EN CAS D'OUVERTURE. EVITER L'EXPOSITION AU FAISCEAU.

GEFAHREN - KLASSE 3B: UNSICHTBARE LASERSTRAHLUNG WENN GEOFFNET. STRAHLENAUSSETZUNG VERMEIDEN.

ATTENZIONE - CLASSE 3B. RADIAZIONI LASER INVISIBILI CON IL DISPOSITIVO APERTO. EVITARE L'ESPOSIZIONE AL RAGGIO.

PRECAUCIÓN - RADIACIÓN LÁSER INVISIBLE DE CLASE 3B PRESENTE AL ABRIR. EVITE LA EXPOSICIÓN AL HAZ.

PERIGO - CLASSE 3B. RADIAÇÃO LASER INVISÍVEL AO ABRIR. EVITE EXPOSIÇÃO DIRECTA AO FEIXE.

GEVAAR - KLASSE 3B. ONZICHTBARE LASERSTRALING INDIEN GEOPEND. VERMIJD BLOOTSTELLING AAN DE STRAAL.

ADVARSEL - KLASSE 3B. USYNLIG LASERSTRÅLING VED ÅBNING. UNDGÅ UDSÆTTELSE FOR STRÅLING.

ADVARSEL - KLASSE 3B. USYNLIG LASERSTRÅLING NÅR DEKSEL ÅPNES. UNNGÅ EKSPONERING FOR STRÅLEN.

VARNING - KLASSE 3B OSYNLIG LASERSTRÅLNING NÅR DENNA DEL ÄR ÖPPNAD. STRÅLEN ÄR FARLIG.

VAROITUS - LUOKAN 3B NÄKYMÄTTÖMÄLLE LASER-SÄTEILYÄ AVATTUNA. VÄLTÄ ALTISTUMISTA SÄTEELLE.

注意 - CLASS 3B。严禁打开, 以免被不可见激光辐射 泄漏灼伤

주의 - 열리면 등급 3B 비가시 레이저 방사선이 방출됩니다. 광선에 노출을 피하십시오.

注意 - CLASS 3B。嚴禁打開, 以免被不可見激光輻射洩漏灼傷

Regulatory information

Ozone safety



This product's ozone emission rate is under 0.1 ppm. Because ozone is heavier than air, keep the product in a place with good ventilation.

Perchlorate warning

This Perchlorate warning applies only to primary CR (Manganese Dioxide) Lithium coin cells in the product sold or distributed ONLY in California USA.

Perchlorate Material - special handling may apply.

See www.dtsc.ca.gov/hazardouswaste/perchlorate. (U.S.A. only)

Power saver



This printer contains advanced energy conservation technology that reduces power consumption when it is not in active use.

When the printer does not receive data for an extended period of time, power consumption is automatically lowered.

ENERGY STAR and the ENERGY STAR mark are registered U.S. marks.

For more information on the ENERGY STAR program see <http://www.energystar.gov>

For ENERGY STAR certified models, the ENERGY STAR label will be on your machine. Check if your machine is ENERGY STAR certified.

Recycling



Recycle or dispose of the packaging material for this product in an environmentally responsible manner.

Regulatory information

Correct disposal of this product (Waste electrical & electronic equipment)

(Applicable in countries with separate collection systems)



This marking on the product, accessories or literature indicates that the product and its electronic accessories (e.g. charger, headset, USB cable) should not be disposed of with other household waste at the end of their working life. To prevent possible harm to the environment or human health from uncontrolled waste disposal, please separate these items from other s of waste and recycle them responsibly to promote the sustainable reuse of material resources.

Household users should contact either the retailer where they purchased this product, or their local government office, for details of where and how they can take these items for environmentally safe recycling.

Business users should contact their supplier and check the terms and conditions of the purchase contract. This product and its electronic accessories should not be mixed with other commercial wastes for disposal.

(The United States of America only)

Dispose unwanted electronics through an approved recycler. To find the nearest recycling location, go to our website: www.samsung.com/recyclingdirect Or call, (877) 278 - 0799

EU REACH SVHC Declaration

For information on Samsung's environmental commitments and product specific regulatory obligations e.g. REACH visit: www.samsung.com/uk/aboutsamsung/samsungelectronics/corporatecitizenship/data_corner.html

State of California Proposition 65 Warning (US Only)

The California Safe Drinking Water and Toxic Enforcement Act requires the Governor of California to publish a list of chemicals known to the State of California to cause cancer or reproductive toxicity and requires businesses to warn of potential exposure to such chemicals.

WARNING: This product contains chemicals known to the State of California to cause cancer, birth defects or other reproductive harm.
This appliance can cause low-level exposure to the chemicals, which can be minimized by operating the appliance in a well ventilated area.

Regulatory information

Radio frequency emissions

FCC information to the user

This device complies with Part 15 of the FCC Rules. Operation is subject to the following two conditions:

- This device may not cause harmful interference, and
- This device must accept any interference received, including interference that may cause undesired operation.

This equipment has been tested and found to comply with the limits for a Class B digital device, pursuant to Part 15 of the FCC Rules. These limits are designed to provide reasonable protection against harmful interference in a residential installation. This equipment generates, uses and can radiate radio frequency energy and, if not installed and used in accordance with the instructions, may cause harmful interference to radio communications. However, there is no guarantee that interference will not occur in a particular installation. If this equipment does cause harmful interference to radio or television reception, which can be determined by turning the equipment off and on, the user is encouraged to try to correct the interference by one or more of the following measures:

- Reorient or relocate the receiving antenna.
- Increase the separation between the equipment and receiver.
- Connect the equipment into an outlet on a circuit different from that to which the receiver is connected.

- Consult the dealer or experienced radio TV technician for help.



Change or modifications not expressly approved by the manufacturer responsible for compliance could void the user's authority to operate the equipment.

Canadian radio interference regulations

This digital apparatus does not exceed the Class B limits for radio noise emissions from digital apparatus as set out in the interference-causing equipment standard entitled "Digital Apparatus", ICES-003 of the Industry and Science Canada.

Cet appareil numérique respecte les limites de bruits radioélectriques applicables aux appareils numériques de Classe B prescrites dans la norme sur le matériel brouilleur: "Appareils Numériques", ICES-003 édictée par l'Industrie et Sciences Canada.

RFID (Radio Frequency Interface Device)

RFID operation is subject to the following two conditions:(1) this device may not cause interference, and (2) this device must accept any interference, including interference that may cause undesired operation of the device. (U.S.A., France, Taiwan only)

Regulatory information

United States of America

Federal Communications Commission (FCC)

Intentional emitter per FCC Part 15

Low power, Radio LAN devices (radio frequency (RF) wireless communication devices), operating in the 2.4 GHz/5 GHz Band, may be present (embedded) in your printer system. This section is only applicable if these devices are present. Refer to the system label to verify the presence of wireless devices.

Wireless devices that may be in your system are only qualified for use in the United States of America if an FCC ID number is on the system label.

The FCC has set a general guideline of 20 cm (8 inches) separation between the device and the body, for use of a wireless device near the body (this does not include extremities). This device should be used more than 20 cm (8 inches) from the body when wireless devices are on. The power output of the wireless device (or devices), which may be embedded in your printer, is well below the RF exposure limits as set by the FCC.

This transmitter must not be collocated or operation in conjunction with any other antenna or transmitter.

Operation of this device is subject to the following two conditions: (1) This device may not cause harmful interference, and (2) this device must accept any interference received, including interference that may cause undesired operation of the device.



Wireless devices are not user serviceable. Do not modify them in any way. Modification to a wireless device will void the authorization to use it. Contact manufacturer for service.

FCC Statement for Wireless LAN use:



While installing and operating this transmitter and antenna combination the radio frequency exposure limit of 1m W/cm² may be exceeded at distances close to the antenna installed. Therefore, the user must maintain a minimum distance of 20cm from the antenna at all times. This device cannot be collocated with another transmitter and transmitting antenna.

Fax Branding

The Telephone Consumer Protection Act of 1991 makes it unlawful for any person to use a computer or other electronic device to send any message via a telephone facsimile machine unless such message clearly contains in a margin at the top or bottom of each transmitted page or on the first page of the transmission the following information:

- 1 the date and time of transmission
- 2 identification of either business, business entity or individual sending the message; and

Regulatory information

- 3 telephone number of either the sending machine, business, business entity or individual.

The Telephone Company may make changes in its communications facilities, equipment operations or procedures where such action is reasonably required in the operation of its business and is not inconsistent with the rules and regulations in FCC Part 68. If such changes can be reasonably expected to render any customer terminal equipment incompatible with telephone company communications facilities, or require modification or alteration of such terminal equipment, or otherwise materially affect its use or performance, the customer shall be given adequate notice in writing, to allow the customer an opportunity to maintain uninterrupted service

Ringer Equivalence Number

The Ringer Equivalence Number and FCC Registration Number for this machine may be found on the label located on the bottom or rear of the machine. In some instances you may need to provide these numbers to the telephone company.

The Ringer Equivalence Number (REN) is a measure of the electrical load placed on the telephone line, and is useful for determining whether you have “overloaded” the line. Installing several s of equipment on the same telephone line may result in problems making and receiving telephone calls, especially ringing when your line is called. The sum of all Ringer Equivalence Numbers of the equipment on your telephone line should be less than five in order to assure proper service from the telephone company. In some cases, a sum of five may not be usable on your line. If any of your telephone equipment is not operating properly, you should immediately remove it from your telephone line, as it may cause harm to the telephone network.

The equipment complies with Part 68 of the FCC rules and the requirements adopted by the ACTA. On the rear of this equipment is a label that contains, among other information, a product identifier in the format US:AAAEQ##TXXXX. If requested, this number must be provided to the telephone company.



FCC Regulations state that changes or modifications to this equipment not expressly approved by the manufacturer could void the user’s authority to operate this equipment. In the event that terminal equipment causes harm to the telephone network, the telephone company should notify the customer that service may be stopped. However, where prior notice is impractical, the company may temporarily cease service, providing that they:

- a promptly notify the customer.
- b give the customer an opportunity to correct the equipment problem.
- c inform the customer of the right to bring a complaint to the Federal Communication Commission pursuant to procedures set out in FCC Rules and Regulations Subpart E of Part 68.

Regulatory information

You should also know that:

- Your machine is not designed to be connected to a digital PBX system.
- If you intend to use a computer modem or fax modem on the same phone line as your machine, you may experience transmission and reception problems with all the equipment. It is recommended that no other equipment, except for a regular telephone, share the line with your machine.
- If your area experiences a high incidence of lightning or power surges, we recommend that you install surge protectors for both the power and the telephone lines. Surge protectors can be purchased from your dealer or telephone and electronic specialty stores.
- When programming emergency numbers and/or making test calls to emergency numbers, use a non-emergency number to advise the emergency service dispatcher of your intentions. The dispatcher will give you further instructions on how to actually test the emergency number.
- This machine may not be used on coin service or party lines.
- This machine provides magnetic coupling to hearing aids.

You may safely connect this equipment to the telephone network by means of a standard modular jack, USOC RJ-11C.

Replacing the Fitted Plug (for UK Only)

Important

The mains lead for this machine is fitted with a standard (BS 1363) 13 amp plug and has a 13 amp fuse. When you change or examine the fuse, you must re-fit the correct 13 amp fuse. You then need to replace the fuse cover. If you have lost the fuse cover, do not use the plug until you have another fuse cover.

Contact the people from you purchased the machine.

The 13 amp plug is the most widely used in the UK and should be suitable. However, some buildings (mainly old ones) do not have normal 13 amp plug sockets. You need to buy a suitable plug adaptor. Do not remove the moulded plug.



If you cut off the moulded plug, get rid of it straight away. You cannot rewire the plug and you may receive an electric shock if you plug it into a socket.

Regulatory information

Important warning:



You must earth this machine.

The wires in the mains lead have the following color code:

- **Green and Yellow:** Earth
- **Blue:** Neutral
- **Brown:** Live

If the wires in the mains lead do not match the colors marked in your plug, do the following:

You must connect the green and yellow wire to the pin marked by the letter “E” or by the safety ‘Earth symbol’ or colored green and yellow or green.

You must connect the blue wire to the pin which is marked with the letter “N” or colored black.

You must connect the brown wire to the pin which is marked with the letter “L” or colored red.

You must have a 13 amp fuse in the plug, adaptor, or at the distribution board.

Taiwan only

警告

本電池如果更換不正確會有爆炸的危險
請依製造商說明書處理用過之電池

Taiwan only

低功率電波輻射性電機管理辦法

- 第十二條** 經型式認證合格之低功率射頻電機，非經許可，公司、商號或使用者均不得擅自變更頻率、加大功率或變更原設計之特性及功能。
- 第十四條** 低功率射頻電機之使用不得影響飛航安全及干擾合法通信；經發現有干擾現象時，應立即停用，並改善至無干擾時方得繼續使用。前項合法通信，指依電信法規定作業之無線電通信。低功率射頻電機須忍受合法通信或工業、科學及醫療用電波輻射性電機設備之干擾。

Russia / Kazakhstan / Belarus only



Изготовитель: «Самсунг Электроникс Ко., Лтд.»
(Мэтан-донг) 129, Самсунг-ро, Енгтонг-гу, г. Сувон, Кёнги-до, Республика Корея
Импортер: ООО «Самсунг Электроникс Рус Компани»
Адрес: 125009, г. Москва, ул. Воздвиженка 10

Самсунг Электроникс Ко. Лтд
(Мэтан-донг) 129, Самсунг-ро, Енгтонг-гу, Сувон қ., Кёнги-до, Корея Республикасы
«САМСУНГ ЭЛЕКТРОНИКС КЗ ЭНД ЦЕНТРАЛ ЭЙЖА» ЖШС
Заңды мекен-жайы:Қазақстан Республикасы, Алматы қ., Әл-Фараби даңғылы, 36, 3,4-қабаттар

Regulatory information

China only

回收和再循环

为了保护环境，我公司已经为废弃的产品建立了回收和再循环系统。我们会为您无偿提供回收同类废旧产品的服务。当您要废弃您正在使用的产品时，请您及时与授权耗材更换中心取得联系，我们会及时为您提供服务。

中国能效标识

| 型号 | 能效等级 | 典型能耗 (kW·h) |
|---------------|------|-------------|
| Xpress C480 | 1 | 0.96 |
| Xpress C480W | 1 | 0.96 |
| Xpress C480FN | 1 | 0.95 |
| Xpress C480FW | 1 | 0.95 |

依据国家标准 GB 21521-2014

Website: <http://www.samsung.com/cn/support/location/supportServiceLocation.do?page=SERVICE.LOCATION>

产品中有害物质的名称及含量

| 部件名称 | 有害物质 | | | | | |
|-------------------|--------|--------|--------|-------------------------|------------|--------------|
| | 铅 (Pb) | 汞 (Hg) | 镉 (Cd) | 六价铬 (Cr ⁶⁺) | 多溴联苯 (PBB) | 多溴二苯醚 (PBDE) |
| 塑料 | ○ | ○ | ○ | ○ | ○ | ○ |
| 金属 (机箱) | × | ○ | ○ | ○ | ○ | ○ |
| 印刷电路部件 (PCA) | × | ○ | ○ | ○ | ○ | ○ |
| 电缆 / 连接器 | × | ○ | ○ | ○ | ○ | ○ |
| 电源设备 | × | ○ | ○ | ○ | ○ | ○ |
| 电源线 | × | ○ | ○ | ○ | ○ | ○ |
| 机械部件 | × | ○ | ○ | ○ | ○ | ○ |
| 卡盒部件 | × | ○ | ○ | ○ | ○ | ○ |
| 定影部件 | × | ○ | ○ | ○ | ○ | ○ |
| 扫描仪部件 - CCD (如果有) | × | × | ○ | ○ | ○ | ○ |
| 扫描仪部件 - 其它 (如果有) | × | ○ | ○ | ○ | ○ | ○ |
| 印刷电路板部件 (PBA) | × | ○ | ○ | ○ | ○ | ○ |
| 墨粉 | ○ | ○ | ○ | ○ | ○ | ○ |
| 滚筒 | ○ | ○ | ○ | ○ | ○ | ○ |

本表格依据 SJ/T 11364 的规定编制。

○：表示该有害物质在该部件所有均质材料中的含量均在 GB/T 26572 规定的限量要求以下。

×：表示该有害物质至少在该部件的某一均质材料中的含量超出 GB/T 26572 规定的限量要求。

Regulatory information

Germany only

Das Gerät ist nicht für die Benutzung am Bildschirmarbeitsplatz gemäß Bildschirmarbeitsverordnung vorgesehen.

Turkey only

- Bu ürünün ortalama yaşam süresi 7 yıl, garanti süresi 2 yıldır.

Thailand only

This telecommunication equipment conforms to NTC technical requirement.

Canada only

This product meets the applicable Industry Canada technical specifications. / Le présent matériel est conforme aux spécifications techniques applicables d'Industrie Canada.

The Ringer Equivalence Number (REN) is an indication of the maximum number of devices allowed to be connected to a telephone interface. The termination of an interface may consist of any combination of devices subject only to the requirement that the sum of the RENs of all the devices not exceed five. / L'indice d'équivalence de la sonnerie (IES) sert à indiquer le nombre maximal de terminaux qui peuvent être raccordés à une interface téléphonique. La terminaison d'une interface peut consister en une combinaison quelconque de dispositifs, à la seule condition que la somme d'indices d'équivalence de la sonnerie de tous les dispositifs n'excede pas cinq.

Declaration of conformity (European countries)

Approvals and Certifications

Hereby, Samsung Electronics, declares that this [Xpress C48x series] is in compliance with the essential requirements and other relevant provisions of Low Voltage Directive (2006/95/EC), EMC Directive (2004/108/EC).



Hereby, Samsung Electronics, declares that this [Xpress C48xW series, Xpress C48xFN series, Xpress C48xFW series] is in compliance with the essential requirements and other relevant provisions of R&TTE Directive 1999/5/EC.

The declaration of conformity may be consulted at www.samsung.com, go to Support > Download center and enter your printer (MFP) name to browse the EuDoC.

Regulatory information

January 1, 1995: Council Directive 2006/95/EC Approximation of the laws of the member states related to low voltage equipment.

January 1, 1996: Council Directive 2004/108/EC, approximation of the laws of the Member States related to electromagnetic compatibility.

March 9, 1999: Council Directive 1999/5/EC on radio equipment and telecommunications terminal equipment and the mutual recognition of their conformity. A full declaration, defining the relevant Directives and referenced standards can be obtained from your Samsung Electronics Co., Ltd. representative.

EC Certification

Certification to 1999/5/EC Radio Equipment & Telecommunications Terminal Equipment Directive (FAX)

This Samsung product has been self-certified by Samsung for pan-European single terminal connection to the analogue public switched telephone network (PSTN) in accordance with Directive 1999/5/EC. The product has been designed to work with the national PSTNs and compatible PBXs of the European countries:

In the event of problems, you should contact the Euro QA Lab of Samsung Electronics Co., Ltd. in the first instance.

The product has been tested against TBR21. To assist in the use and application of terminal equipment which complies with this standard, the European Telecommunication Standards Institute (ETSI) has issued an advisory document (EG 201 121) which contains notes and additional requirements to ensure network compatibility of TBR21 terminals. The product has been designed against, and is fully compliant with, all of the relevant advisory notes contained in this document.

European radio approval information (for products fitted with EU-approved radio devices)

Low power, Radio LAN type devices (radio frequency (RF) wireless communication devices), operating in the 2.4 GHz/5 GHz band, may be present (embedded) in your printer system which is intended for home or office use. This section is only applicable if these devices are present. Refer to the system label to verify the presence of wireless devices.



Wireless devices that may be in your system are only qualified for use in the European Union or associated areas if a CE mark is on the system label.

The power output of the wireless device or devices that may be embedded in your printer is well below the RF exposure limits as set by the European Commission through the R&TTE directive.

European states qualified under wireless approvals:

EU countries

Regulatory information

European states with restrictions on use:

EU

EEA/EFTA countries

No limitations at this time

Regulatory compliance statements

Wireless guidance

Low power, Radio LAN devices (radio frequency (RF) wireless communication devices), operating in the 2.4 GHz/5 GHz Band, may be present (embedded) in your printer system. The following section is a general overview of considerations while operating a wireless device.

Additional limitations, cautions, and concerns for specific countries are listed in the specific country sections (or country group sections). The wireless devices in your system are only qualified for use in the countries identified by the Radio Approval Marks on the system rating label. If the country you will be using the wireless device in, is not listed, contact your local Radio Approval agency for requirements. Wireless devices are closely regulated and use may not be allowed.

The power output of the wireless device or devices that may be embedded in your printer is well below the RF exposure limits as known at this time. Because the wireless devices (which may be embedded into your printer) emit less energy than is allowed in radio frequency safety standards and recommendations, manufacturer believes these devices are safe for use. Regardless of the power levels, care should be taken to minimize human contact during normal operation.

As a general guideline, a separation of 20 cm (8 inches) between the wireless device and the body, for use of a wireless device near the body (this does not include extremities) is typical. This device should be used more than 20 cm (8 inches) from the body when wireless devices are on and transmitting.

This transmitter must not be collocated or operation in conjunction with any other antenna or transmitter.

Some circumstances require restrictions on wireless devices. Examples of common restrictions are listed below:



Radio frequency wireless communication can interfere with equipment on commercial aircraft. Current aviation regulations require wireless devices to be turned off while traveling in an airplane. IEEE 802.11 (also known as wireless Ethernet) and Bluetooth communication devices are examples of devices that provide wireless communication.

Regulatory information



In environments where the risk of interference to other devices or services is harmful or perceived as harmful, the option to use a wireless device may be restricted or eliminated. Airports, Hospitals, and Oxygen or flammable gas laden atmospheres are limited examples where use of wireless devices may be restricted or eliminated. When in environments where you are uncertain of the sanction to use wireless devices, ask the applicable authority for authorization prior to use or turning on the wireless device.



Every country has different restrictions on the use of wireless devices. Since your system is equipped with a wireless device, when traveling between countries with your system, check with the local Radio Approval authorities prior to any move or trip for any restrictions on the use of a wireless device in the destination country.



If your system came equipped with an internal embedded wireless device, do not operate the wireless device unless all covers and shields are in place and the system is fully assembled.



Wireless devices are not user serviceable. Do not modify them in any way. Modification to a wireless device will void the authorization to use it. Contact manufacturer for service.



Only use drivers approved for the country in which the device will be used. See the manufacturer System Restoration Kit, or contact manufacturer Technical Support for additional information.

Copyright

© 2015 Samsung Electronics Co., Ltd. All rights reserved.

This user's guide is provided for information purposes only. All information included herein is subject to change without notice.

Samsung Electronics is not responsible for any direct or indirect damages, arising from or related to use of this user's guide.

- Samsung and the Samsung logo are trademarks of Samsung Electronics Co., Ltd.
- Microsoft, Windows, Windows Vista, Windows 7, Windows 8, Windows Server 2008 R2, Windows 10 and Windows Server 2016 are either registered trademarks or trademarks of Microsoft Corporation.
- Microsoft, Internet Explorer, Excel, Word, PowerPoint, and Outlook are either registered trademarks or trademarks of Microsoft Corporation in the United States and other countries.
- Google, Picasa, Google Cloud Print, Google Docs, Android and Gmail are either registered trademarks or trademarks of Google Inc.
- iPad, iPhone, iPod touch, Mac and Mac OS are trademarks of Apple Inc., registered in the U.S and other countries.
- AirPrint and the AirPrint logo are trademarks of Apple Inc.
- All other brand or product names are trademarks of their respective companies or organizations.



QR code

The software included in this product contains open source software. You may obtain the complete corresponding source code for a period of three years after the last shipment of this product by sending an email to <mailto:oss.request@samsung.com>. It is also possible to obtain the complete corresponding source code in a physical medium such as a CD-ROM; a minimal charge will be required.

The following URL https://opensource.samsung.com/opensource/Samsung_C48x_Series/seq/48 leads to the download page of the source code made available and open source license information as related to this product. This offer is valid to anyone in receipt of this information.

User's Guide

ADVANCED

This guide provides information about installation, advanced configuration, operation and troubleshooting on various OS environments.

Some features may not be available depending on models or countries.

BASIC

This guide provides information concerning installation, basic operation and troubleshooting on windows.



1. Software Installation

| | |
|---------------------------------|-----|
| Installation for Mac | 151 |
| Reinstallation for Mac | 152 |
| Installation for Linux | 153 |
| Reinstallation for Linux | 154 |



2. Using a Network-Connected Machine

| | |
|---|-----|
| Useful network programs | 156 |
| Wired network setup | 157 |
| Installing driver over the network | 160 |
| IPv6 configuration | 165 |
| Wireless network setup | 168 |
| Samsung Mobile Print | 186 |
| Using the NFC feature | 187 |
| Mopria™ | 194 |
| AirPrint | 196 |
| Samsung Cloud Print | 198 |
| Google Cloud Print™ | 201 |



3. Useful Setting Menus

| | |
|---|-----|
| Before you begin reading a chapter | 205 |
| Print | 206 |
| Copy | 207 |
| Fax | 210 |
| Scan | 214 |
| System setup | 216 |
| Network setup | 222 |



4. Special Features

| | |
|--|-----|
| Altitude adjustment | 225 |
| Entering various characters | 226 |
| Setting up the fax address book | 228 |
| Printing features | 231 |
| Scan features | 242 |
| Fax features | 249 |



5. Useful Management Tools

| | |
|-----------------------------------|-----|
| Accessing management tools | 258 |
|-----------------------------------|-----|

| | |
|--|------------|
| Easy Capture Manager | 259 |
| Samsung Easy Color Manager | 260 |
| Easy Eco Driver | 261 |
| Using Samsung Printer Center | 262 |
| Using SyncThru™ Web Service | 266 |
| Using Samsung Easy Printer Manager | 269 |
| Using Samsung Easy Document Creator | 272 |
| Using Samsung Printer Status | 273 |
| Using Samsung Printer Experience | 275 |



6. Troubleshooting

| | |
|--|------------|
| Paper feeding problems | 283 |
| Power and cable connecting problems | 284 |
| Printing problems | 285 |
| Printing quality problems | 289 |
| Copying problems | 297 |
| Scanning problems | 298 |
| Faxing problems | 299 |
| Operating system problems | 301 |



1. Software Installation

This chapter provides instructions for installing essential and helpful software for use in an environment where the machine is connected via a cable. A locally connected machine is a machine directly attached to your computer using a USB cable. If your machine is attached to a network, skip the following steps below and go on to installing a network connected machine's driver (see "Installing driver over the network" on page 160).

- **Installation for Mac** **151**
- **Reinstallation for Mac** **152**
- **Installation for Linux** **153**
- **Reinstallation for Linux** **154**



- If you are a Windows OS user, refer to the Basic Guide for installing the machine's driver (see "Installing the driver locally" on page 29).
- Only use a USB cable no longer than 3 meter (118 inches).

Installation for Mac

- 1 Make sure that the machine is connected to your computer and powered on.
- 2 Insert the supplied software CD into your CD-ROM drive.
- 3 Select the CD-ROM volume that appears on **Finder**.
- 4 Double-click the **Install Software** icon.
- 5 Read the license agreement and check installation agreement button.
- 6 Click **Next** and then follow the instructions in the installation window.



To install the fax driver:

- a Open the **Applications** folder > **Samsung** > **Fax Queue Creator**.
- b Your machine appears on the **Printer List**
- c Select machine to use and click **Create** button

Reinstallation for Mac

If the printer driver does not work properly, uninstall the driver and reinstall it.

- 1 Open the **Applications** folder > **Samsung** > **Printer Software Uninstaller**.
- 2 To uninstall printer software, click **Continue**.
- 3 Check the program you want to delete and click **Uninstall**.
- 4 Enter the password and click **OK**.
- 5 After the uninstallation is finished, click **Close**.



If a machine has already been added, delete it from the **Print Setup Utility** or **Print & Fax**.

Installation for Linux

You need to download Linux software packages from the Samsung website to install the printer software (<http://www.samsung.com> > find your product > Support or Downloads).

Installing the Unified Linux Driver



You must log in as a super user (root) to install the machine software. If you are not a super user, ask your system administrator.

- 1 Make sure that the machine is connected to your computer and powered on.
- 2 Copy **Unified Linux Driver** package to your system.
- 3 Open Terminal program and go to the folder that you copied the package to.
- 4 Extract the package.
- 5 Move to **uld** folder.
- 6 Execute **./install.sh** command (If you're not logged in as root, execute the command with **sudo** as **sudo ./install.sh**)
- 7 Proceed with installation.

- 8 When installation finished, launch printing utility(Go to **System** > **Administration** > **Printing** or execute **"system-config-printer"** command in Terminal program).
- 9 Click **Add** button.
- 10 Select your printer.
- 11 Click **Forward** button and add it to your system.

Reinstallation for Linux

If the printer driver does not work properly, uninstall the driver and reinstall it.

- 1 Open **Terminal** program.
- 2 Move to **uld** folder extracted from **Unified Linux Driver** package.
- 3 Execute "**./uninstall.sh**" command (If you're not logged in as root, execute the command with "**sudo**" as "**sudo ./uninstall.sh**")
- 4 Proceed with uninstallation.



2. Using a Network-Connected Machine

This chapter gives you step-by-step instructions for setting up a network connected machine and software.

- **Useful network programs** 156
- **Wired network setup** 157
- **Installing driver over the network** 160
- **IPv6 configuration** 165
- **Wireless network setup** 168
- **Samsung Mobile Print** 186
- **Using the NFC feature** 187
- **Mopria™** 194
- **AirPrint** 196
- **Samsung Cloud Print** 198
- **Google Cloud Print™** 201



Supported optional devices and features may differ according to your model (see "Features by model" on page 7).

Useful network programs

There are several programs available to setup the network settings easily in a network environment. For the network administrator especially, managing several machines on the network is possible.



- Before using the programs below, set the IP address first.
- Some features and optional goods may not be available depending on model or country (see "Features by model" on page 7).

SyncThru™ Web Service

The web server embedded on your network machine allows you to do the following tasks (see "Using SyncThru™ Web Service" on page 265).

- Check the supplies information and status.
- Customize machine settings.
- Set the email notification option. When you set this option, the machine status (toner cartridge shortage or machine error) will be sent to a certain person's email automatically.
- Configure the network parameters necessary for the machine to connect to various network environments.

SetIP wired network setup

This utility program allows you to select a network interface and manually configure the IP addresses for use with the TCP/IP protocol.

- See "IPv4 configuration using SetIP (Windows)" on page 157.
- See "IPv4 configuration using SetIP (Mac)" on page 158.
- See "IPv4 configuration using SetIP (Linux)" on page 158.



- If your device does not support a network connection, it will not be able to use this feature (see "Rear view" on page 23).
- TCP/IPv6 is not supported by this program.

Wired network setup

Printing a network configuration report

You can print **Network Configuration Report** from the machine's control panel that will show the current machine's network settings. This will help you to set up a network.

Press the  (**Menu**) button on the control panel and select **Network > Network Conf. .**

Using this **Network Configuration Report**, you can find your machine's MAC address and IP address.

For example:

- MAC Address: 00:15:99:41:A2:78
- IP Address: 169.254.192.192

Setting IP address



- If your device does not support a network connection, it will not be able to use this feature (see "Rear view" on page 23).
- TCP/IPv6 is not supported by this program.

First, you have to set up an IP address for network printing and managements. In most cases a new IP address will be automatically assigned by a DHCP (Dynamic Host Configuration Protocol) server located on the network.

IPv4 configuration using SetIP (Windows)

Before using the SetIP program, disable the computer firewall from **Control Panel > Security Center > Windows Firewall**.



The following instructions may differ for your model.

- 1 Download the software from the Samsung website then unpack and install it: (<http://www.samsung.com> > find your product > Support or Downloads).
- 2 Follow the instructions in the installation window.
- 3 Connect your machine to the network with a network cable.
- 4 Turn on the machine.
- 5 From the Windows **Start** menu, select **All Programs > Samsung Printers > SetIP > SetIP**.
- 6 Click the  icon (third from left) in the SetIP window to open the TCP/IP configuration window.

Wired network setup

- 7 Enter the machine's new information into the configuration window. In a corporate intranet, you may need to have this information assigned by a network manager before proceeding.



Find the machine's MAC address from the **Network Configuration Report** (see "Printing a network configuration report" on page 157) and enter it without the colons. For example, 00:15:99:29:51:A8 becomes 0015992951A8.

- 8 Click **Apply**, and then click **OK**. The machine will automatically print the **Network Configuration Report**. Confirm that all the settings are correct.

IPv4 configuration using SetIP (Mac)

Before using the SetIP program, disable the computer firewall from **System Preferences > Security** (or **Security & Privacy**) > **Firewall**.

- 1 Download the software from the Samsung website then unpack and install it: (<http://www.samsung.com> > find your product > Support or Downloads).
- 2 Turn on the machine.
- 3 Run downloaded **SetIP** application.

- 4 Click the  icon (third from left) in the SetIP window to open the TCP/IP configuration window.

- 5 Enter the machine's new information into the configuration window. In a corporate intranet, you may need to have this information assigned by a network manager before proceeding.



Find the machine's MAC address from the **Network Configuration Report** (see "Printing a network configuration report" on page 157) and enter it without the colons. For example, 00:15:99:29:51:A8 becomes 0015992951A8.

- 6 Click **Apply**, and then click **OK**. The machine will automatically print the **Network Configuration Report**. Confirm that all the settings are correct.

IPv4 configuration using SetIP (Linux)

Before using the SetIP program, disable the computer firewall from **System Preferences** or **Administrator**.



The following instructions may vary from your model or operating systems.

Wired network setup

- 1 Download SetIP program from Samsung web site and extract it.
- 2 Double-click the **SetIPApplet.html** file in `cdroot/Linux/noarch/at_opt/share/utils` folder.
- 3 Click to open the TCP/IP configuration window.
- 4 Enter the machine's new information into the configuration window. In a corporate intranet, you may need to have this information assigned by a network manager before proceeding.



Find the machine's MAC address from the **Network Configuration Report** (see "Printing a network configuration report" on page 157) and enter it without the colons. For example, `00:15:99:29:51:A8` becomes `0015992951A8`.

- 5 The machine will automatically print the **Network Configuration Report**.

Installing driver over the network



- Some features and optional goods may not be available depending on model or country (see "Features by model" on page 7).
- The machine that does not support the network interface, it will not be able to use this feature (see "Rear view" on page 23).
- You can install the printer driver and software when you insert the software CD into your CD-ROM drive. For windows, select the printer driver and software in the **Select Software to Install** window.

Windows



The firewall software might be blocking network communication. Before connecting the device to the network, disable the computer's firewall.

- 1** Make sure that the machine is connected to the network and powered on. Also, your machine's IP address should have been set (see "Setting IP address" on page 157).
- 2** Insert the supplied software CD into your CD-ROM drive.
If the installation window does not appear, click **Start > All programs > Accessories > Run**.
X:\Setup.exe replacing "X" with the letter, which represents your CD-ROM drive and click **OK**.
•For Windows 8,
If the installation window does not appear, from **Charms**, select **Search > Apps** and search for **Run**. Type in X:\Setup.exe, replacing "X" with the letter that represents your CD-ROM drive and click **OK**.
If "**Tap to choose what happens with this disc.**" pop-up window appears, click the window and select **Run Setup.exe**.
- 3** Review and accept the installation agreements in the installation window. Then, click **Next**.
- 4** Select **Network** on the **Printer Connection Type** screen Then,click **Next**.
- 5** Follow the instructions in the installation window.

Installing driver over the network

From the Windows 8 Start Screen



- The V4 driver is automatically downloaded from the Windows Update if your computer is connected to the Internet. If not, you can manually download the V4 driver from Samsung website, <http://www.samsung.com> > find your product > Support or downloads.
- You can download **Samsung Printer Experience** app from the **Windows Store**. You need have a Microsoft account to use the Windows Store.
 - a From **Charms**, select **Search**.
 - b Click **Store**.
 - c Search and click **Samsung Printer Experience**.
 - d Click **Install**.
- If you install the driver using the supplied software CD, V4 driver is not installed. If you want to use the V4 driver in the **Desktop** screen, you can download from the Samsung website, <http://www.samsung.com> > find your product > Support or downloads.
- If you want to install Samsung's printer management tools, you need to install them using the supplied software CD.

- 1 Make sure that the machine is connected to the network and powered on. Also, your machine's IP address should have been set (see "Setting IP address" on page 157).
- 2 From **Charms**, select **Settings** > **Change PC settings** > **Devices**.
- 3 Click **Add a device**.
Discovered machines will be shown on the screen.

- 4 Click the model name or host name you wish to use.



You can print a Network Configuration Report from the machine's control panel that will show the current machine's host name (see "Printing a network configuration report" on page 178).

- 5 The driver is automatically installed from the **Windows Update**.

Silent installation Mode

Silent installation mode is an installation method that does not require any user intervention. Once you start the installation, the machine driver and software are automatically installed on you computer. You can start the silent installation by typing **/s** or **/S** in the command window.



Command-line Parameters

Following table shows commands that can be used in the command window.



Following command-line are effective and operated when command is used with **/s** or **/S**. But **/h**, **/H** or **/?** are exceptional commands that can be operated solely.

Installing driver over the network

| Command- line | Definition | Description |
|-----------------------------------|---|--|
| /s or/S | Starts silent installation. | Installs machine drivers without prompting any UIs or user intervention. |
| /p"<port name>" or/P"<port name>" | Specifies printer port.  Network Port will be created by use of Standard TCP/IP Port monitor. For local port, this port must exist on system before being specified by command. | Printer port name can be specified as IP address, hostname, USB local port name or IEEE1284 port name. For example: <ul style="list-style-type: none"> • /p"xxx.xxx.xxx.xxx" in where, "xxx.xxx.xxx.xxx" means IP address for network printer. /p"USB001", /P"LPT1:", /p"hostname" |
| /a"<dest_path>" or/A"<dest_path>" | Specifies destination path for installation.  The destination path should be a fully qualified path. | Since machine drivers should be installed on the OS specific location, this command applies to only application software. |

| Command- line | Definition | Description |
|---|---|---|
| /n"<Printer name>" or/N"<Printer name>" | Specifies printer name. Printer instance shall be created as specified printer name. | With this parameter, you can add printer instances as you wish. |
| /nd or/ND | Commands not to set the installed driver as a default machine driver. | It indicates installed machine driver will not be the default machine driver on your system if there are one or more printer drivers installed. If there is no installed machine driver on your system, then this option won't be applied because Windows OS will set installed printer driver as a default machine driver. |
| /x or/X | Uses existing machine driver files to create printer instance if it is already installed. | This command provides a way to install a printer instance that uses installed printer driver files without installing an additional driver. |

Installing driver over the network

| Command- line | Definition | Description |
|---|--|---|
| /up"<printer name>" or/UP"<printer name>" | Removes only specified printer instance and not the driver files. | This command provides a way to remove only specified printer instance from your system without effecting other printer drivers. It will not remove printer driver files from your system. |
| /d or/D | Uninstalls all device drivers and applications from your system. | This command will remove all installed device drivers and application software from your system. |
| /v"<share name>" or/V"<share name>" | Shares installed machine and add other available platform drivers for Point & Print. | It will install all supported Windows OS platform's machine drivers to system and share it with specified <share name> for point and print. |
| /o or /O | Opens Printers and Faxes folder after installation. | This command will open Printers and Faxes folder after the silent installation. |
| /h, /H or /? | Shows Command-line Usage. | |

Mac

- 1 Make sure that the machine is connected to your computer and powered on.
- 2 Insert the supplied software CD into your CD-ROM drive.
- 3 Select the CD-ROM volume that appears on **Finder**.
- 4 Double-click the **Install Software** icon.
- 5 Read the license agreement and check installation agreement button.
- 6 Click **Next**.
- 7 Select **Network** on the printer connection type screen.
- 8 Click **Next**.
- 9 Follow the instructions in the installation window.

Installing driver over the network

Linux

You need to download Linux software packages from the Samsung website to install the printer software (<http://www.samsung.com> > find your product > Support or Downloads).

- 1 Make sure that the machine is connected to your network and powered on. Also, your machine's IP address should have been set.
- 2 Copy **Unified Linux Driver** package to your system.
- 3 Open Terminal program and go to the folder that you copied the package to.
- 4 Extract the package.
- 5 Move to **uld** folder.
- 6 Execute `./install.sh` command (If you are not logged in as root, execute the command with `sudo` as `sudo ./install.sh`).
- 7 Proceed with installation.
- 8 When installation finished, launch **Printing** utility (Go to **System** > **Administration** > **Printing** or execute `system-config-printer` command in Terminal program).
- 9 Click **Add** button.

- 10 Select **AppSocket/HP JetDirect** and enter your machine's IP address.
- 11 Click **Forward** button and add it to your system.

Add a network printer

- 1 Double-click the **Unified Driver Configurator**.
- 2 Click **Add Printer**.
- 3 The **Add printer wizard** window opens. Click **Next**.
- 4 Select **Network printer** and click the **Search** button.
- 5 The printer's IP address and model name appears on list field.
- 6 Select your machine and click **Next**.
- 7 Enter the printer description and click **Next**.
- 8 After the machine is added, click **Finish**.

IPv6 configuration



IPv6 is supported properly only in Windows Vista or higher.



- Some features and optional goods may not be available depending on model or country (see "Features by model" on page 7 or "Menu overview" on page 34).
- If the IPv6 network seems to not be working, set all the network setting to the factory defaults and try again using **Clear Setting**.

The machine supports the following IPv6 addresses for network printing and managements.

- **Link-local Address:** Self-configured local IPv6 address (Address starts with FE80).
- **Stateless Address:** Automatically configured IPv6 address by a network router.
- **Stateful Address:** IPv6 address configured by a DHCPv6 server.
- **Manual Address:** Manually configured IPv6 address by a user.

In the IPv6 network environment, follow the next procedure to use the IPv6 address.

From the control panel

Activating IPv6

- 1 Press the  (**Menu**) button on the control panel.
- 2 Press **Network > TCP/IP (IPv6) > IPv6 Protocol**
- 3 Select **On** and press **OK**.
- 4 Turn the machine off and turn it on again.



When you install the printer driver, do not configure both IPv4 and IPv6. We recommend to configure either IPv4 or IPv6 (see "Installing driver over the network" on page 160).

DHCPv6 address configuration

If you have a DHCPv6 server on your network, you can set one of the following options for default dynamic host configuration.

- 1 Press the  (**Menu**) button on the control panel.
- 2 Press **Network > TCP/IP (IPv6) > DHCPv6 Config**

IPv6 configuration

- 3 Press **OK** to select the required value you want.
 - Router:** Use DHCPv6 only when requested by a router.
 - Always Use:** Always use DHCPv6 regardless of router request.
 - Never Use:** Never use DHCPv6 regardless of router request.

From the SyncThru™ Web Service

Activating IPv6

- 1 Access a web browser, such as Internet Explorer, from Windows. Enter the machine IP address (http://xxx.xxx.xxx.xxx) in the address field and press the Enter key or click **Go**.
- 2 If it's your first time logging into **SyncThru™ Web Service** you need to log-in as an administrator. Type in the below default ID and password. We recommend you to change the default password for security reasons.
 - ID:** admin
 - Password:** sec00000
- 3 When the **SyncThru™ Web Service** window opens, move the mouse cursor over the **Settings** of the top menu bar and then click **Network Settings**.
- 4 Click **TCP/IPv6** on the left pane of the website.

- 5 Check the **IPv6 Protocol** check box to activate IPv6.
- 6 Click the **Apply** button.
- 7 Turn the machine off and turn it on again.



- You can also set the DHCPv6.
- To manually set the IPv6 address:
Check the **Manual Address** check box. Then, the **Address/Prefix** text box is activated. Enter the rest of the address (e.g.,:3FFE:10:88:194::**AAAA**. "A" is the hexadecimal 0 through 9, A through F).

IPv6 address configuration

- 1 Start a web browser, such as Internet Explorer, that supports IPv6 addressing as a URL.
- 2 Select one of the IPv6 addresses (**Link-local Address**, **Stateless Address**, **Stateful Address**, **Manual Address**) from **Network Configuration Report** (see "Printing a network configuration report" on page 157).
 - Link-local Address:** Self-configured local IPv6 address (Address starts with FE80).
 - Stateless Address:** Automatically configured IPv6 address by a network router.

IPv6 configuration

•**Stateful Address:** IPv6 address configured by a DHCPv6 server.

•**Manual Address:** Manually configured IPv6 address by a user.

3 Enter the IPv6 addresses (e.g.,: `http://[FE80::215:99FF:FE66:7701]`).



Address must be enclosed in '[' brackets.

Wireless network setup



- Wireless networking may not be available depending on the model (see "Features by model" on page 7).

Wireless networks require higher security, so when an access point is first set up, a network name (SSID), the type of security used, and a Network Password are created for the network. Ask your network administrator about this information before proceeding with the machine installation.

Introducing wireless set up methods

You can set wireless settings either from the machine or the computer. Choose the setting method from the below table.



- Some wireless network installation types may not be available depending on the model or country.
- It is strongly recommended that you set the password on Access Points. If you do not set the password on Access Points, they might be exposed to illegal access from unknown machines including PCs, smart phones and printers. Refer to the Access Point user' guide for password settings.

Wireless network setup

| Set up method | Connecting method | Description & Reference |
|---|---|---|
| With Access Point | From the computer | See "Setting up via USB cable" on page 172 for Window. |
| | | See "Access point without a USB cable" on page 174 for Window. |
| | | See "Setting up via USB cable" on page 176 for Mac. |
| | | See "Access point without a USB cable" on page 177 for Mac. |
| | | See "Using a network cable" on page 178. |
| | From the machine's control panel | See "Using the WPS Settings menu" on page 169. |
| See "Using the Wi-Fi Networks" on page 171. | | |
| Wi-Fi Direct setup | | See "Setting the Wi-Fi Direct for mobile printing" on page 180. |

Using the WPS Settings menu

If your machine and access point (or wireless router) support Wi-Fi Protected Setup™ (WPS), then you can easily configure the wireless network settings through the **WPS Settings** menu without the need for a computer.



- If you want to use the wireless network using the infrastructure mode, make sure that the network cable is disconnected from the machine. Using the **WPS (PBC)** button or entering the PIN from the computer to connect to the access point (or wireless router) varies depending on the access point (or wireless router) you are using. Refer to the user's guide of the access point (or wireless router) you are using.
- When using the WPS button to set the wireless network, security settings may change. To prevent this, lock the WPS option for the current wireless security settings. The option name may differ depending on the access point (or wireless router) you are using.

Items to prepare

- Check if the access point (or wireless router) supports Wi-Fi Protected Setup™ (WPS).
- Check if your machine supports Wi-Fi Protected Setup™ (WPS).
- Networked computer (PIN mode only)

Wireless network setup

Choosing your type

There are two methods available to connect your machine to a wireless network.

- The **Push Button Configuration (PBC)** method allows you to connect your machine to a wireless network by pressing both the **WPS Settings** menu on the control panel of your machine and the WPS (PBC) button on a Wi-Fi Protected Setup™ WPS-enabled access point (or wireless router) respectively.
- The **Personal Identification Number (PIN)** method helps you connect your machine to a wireless network by entering the supplied PIN information on a Wi-Fi Protected Setup™ WPS-enabled access point (or wireless router).

Connecting WPS

Factory default in your machine is **PBC** mode, which is recommended for a typical wireless network environment.

Connecting in PBC mode

- 1 Press the  (**Menu**) button on the control panel and select **Network**.
- 2 Press **Wi-Fi**.
- 3 Press **WPS > PBC**.
- 4 Press the **WPS (PBC)** button on the access point (or wireless router).
- 5 Follow the instruction on the display screen.
The messages are displayed on the display screen.

Connecting in PIN mode

- 1 Press the  (**Menu**) button on the control panel and select **Network**.
- 2 Press **Wi-Fi**.
- 3 Press **WPS > PIN**.

Wireless network setup

- 4 The eight-digit PIN appears on the display.
You need to enter the eight-digit PIN within two minutes on the computer that is connected to the access point (or wireless router).



You need to enter the PIN from the computer to connect to the access point (or wireless router) varies depending on the access point (or wireless router) you are using. Refer to the user's guide of the access point (or wireless router) you are using.

- 5 Follow the instruction on the display screen.
The messages are displayed on the display screen.

Using the Wi-Fi Networks

Before starting, you will need to know the network name (SSID) of your wireless network and the network key if it is encrypted. This information was set when the access point (or wireless router) was installed. If you do not know about your wireless environment, please ask the person who set up your network.

- 1 Press the  (**Menu**) button on the control panel and select **Network** from the display screen.
- 2 Press **Wi-Fi On/Off** > ON.
- 3 The machine will display a list of available networks from which to choose. After a network is chosen then printer will prompt for the corresponding security key.
- 4 Select the Wi-Fi network option you want.

Wireless network setup

Setup using Windows



Shortcut to the **Samsung Easy Wireless Setup** program without the CD: If you have installed the printer driver once, you can access the **Samsung Easy Wireless Setup** program without the CD.

Setting up via USB cable

Items to prepare

- Access point
- Network-connected computer
- Software CD that was provided with your machine
- A machine installed with a wireless network interface
- USB cable

Creating the infrastructure network

- 1 Check whether the USB cable is connected to the machine.
- 2 Turn on your computer, access point, and machine.

- 3 Insert the supplied software CD into your CD-ROM drive.

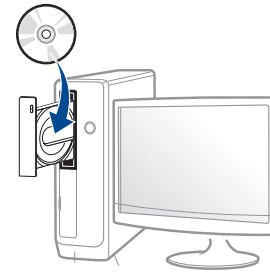

If the installation window does not appear, click **Start > All programs > Accessories > Run**.

X:\Setup.exe replacing "X" with the letter, which represents your CD-ROM drive and click **OK**.

•For Windows 8,

If the installation window does not appear, from **Charms**, select **Search > Apps** and search for **Run**. Type in X:\Setup.exe, replacing "X" with the letter that represents your CD-ROM drive and click **OK**.

If "**Tap to choose what happens with this disc.**" pop-up window appears, click the window and select **Run Setup.exe**.

- 4 Review and accept the installation agreements in the installation window. Then, click **Next**.
- 5 Select **Wireless** on the **Printer Connection Type** screen. Then, click **Next**.

Wireless network setup

- 6 On the **Are you setting up your printer for the first time?** screen, select **Yes, I will set up my printer's wireless network.** Then, click **Next.**

If your printer is already connected on the network, select **No, my printer is already connected to my network.**

- 7 Select **Using a USB cable** on the **Select the Wireless Setup Method** screen. Then, click **Next.**

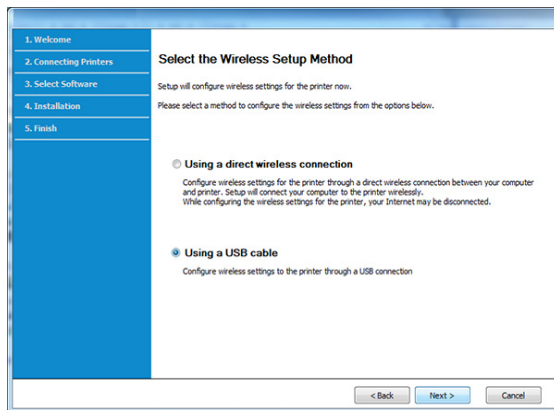

- 8 After searching, the window shows the wireless network devices. Select the name (SSID) of the access point you want to use and click **Next.**



If you cannot find the network name you want to choose, or if you want to set the wireless configuration manually, click **Advanced Setting.**

- **Enter the wireless Network Name:** Enter the SSID of the access point (SSID is case-sensitive).
- **Operation Mode:** Select **Infrastructure.**

- **Authentication:** Select an authentication type.
 - **Open System:** Authentication is not used, and encryption may or may not be used, depending on the need for data security.
 - **Shared Key:** Authentication is used. A device that has a proper WEP key can access the network.
 - **WPA Personal or WPA2 Personal:** Select this option to authenticate the print server based on a WPA Pre-Shared Key. This uses a shared secret key (generally called Pre Shared Key pass phrase), which is manually configured on the access point and each of its clients.
- **Encryption:** Select the encryption (None, WEP64, WEP128, TKIP, AES).
- **Network Password:** Enter the encryption network password value.
- **Confirm Network Password:** Confirm the encryption network password value.
- **WEP Key Index:** If you are using WEP Encryption, select the appropriate **WEP Key Index.**

The wireless network security window appears when the access point has security settings.
Enter the Network Password of the access point (or router).

Wireless network setup

- 9 If your printer supports Wi-Fi Direct, the following screen appears.
Click **Next**.

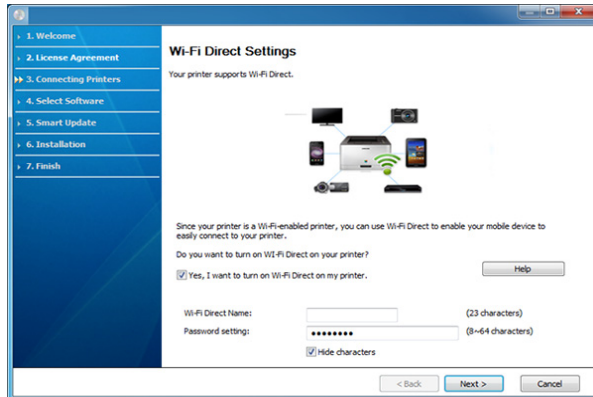

- Wi-Fi Direct option appears on the screen only if your printer supports this feature.
- Can start to build Wi-Fi Direct by using Samsung Easy Printer Manager (see "Setting up Wi-Fi Direct" on page 180).
- **Wi-Fi Direct Name:** The default Wi-Fi Direct Name is the model name and the maximum length is 22 characters.
- **Password setting** is the numeric string, and the size is 8 ~ 64 characters.

- 10 When the wireless network set up is completed, disconnect the USB cable between the computer and machine. Click **Next**.

- 11 Select the components to be installed.

- 12 Follow the instructions in the installation window.

Access point without a USB cable

Items to prepare

- WiFi-enabled PC running Windows 7 or higher and an access point (router)
- Software CD that was provided with your machine
- A machine installed with a wireless network interface



While setting the wireless network, the machine uses PC's wireless LAN. You might not be able to connect to the Internet.

Wireless network setup

Creating the infrastructure network

- 1 Turn on your computer, access point, and machine.
- 2 Insert the supplied software CD into your CD-ROM drive.



If the installation window does not appear, click **Start > All programs > Accessories > Run**.

X:\Setup.exe replacing "X" with the letter, which represents your CD-ROM drive and click **OK**.

•For Windows 8,

If the installation window does not appear, from **Charms**, select **Search > Apps** and search for **Run**. Type in X:\Setup.exe, replacing "X" with the letter that represents your CD-ROM drive and click **OK**.

If "Tap to choose what happens with this disc." pop-up window appears, click the window and select **Run Setup.exe**.

- 3 Review and accept the installation agreements in the installation window. Then, click **Next**.
- 4 Select **Wireless** on the **Printer Connection Type** screen. Then, click **Next**.

- 5 On the **Are you setting up your printer for the first time?** screen, select **Yes, I will set up my printer's wireless network**. Then, click **Next**.

If your printer is already connected on the network, select **No, my printer is already connected to my network**.

- 6 Select **Using a direct wireless connection** on the **Select the Wireless Setup Method** screen. Then, click **Next**.

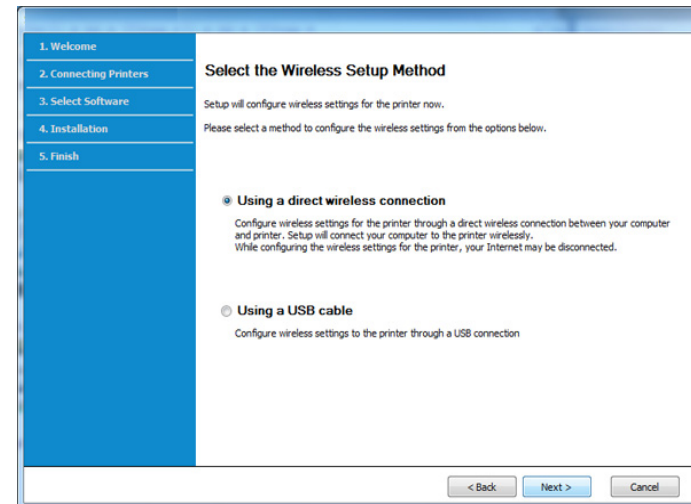

- Even if your computer is running Windows 7 or higher, you cannot use this feature if your PC does not support wireless network. Set the wireless network using a USB cable (see "Setting up via USB cable" on page 172).
- If below screen appears, press the  (WPS) button from the control panel within 2 minutes.

- 7 When the wireless network set up is completed, click **Next**.

- 8 Follow the instructions in the installation window.

Wireless network setup

Setup using Mac

Items to prepare

- Access point
- Network-connected computer
- Software CD that was provided with your machine
- A machine installed with a wireless network interface
- USB cable

Setting up via USB cable

- 1 Make sure that the machine is connected to your computer and powered on.
- 2 Insert the supplied software CD into your CD-ROM drive.
- 3 Select the CD-ROM volume that appears on **Finder**.
- 4 Double-click **Install Software** icon.
- 5 Read the license agreement and check installation agreement button.
- 6 Click **Next**.

7 Select **Wireless** on the **Printer Connection Type**.

8 Click **Next**.

9 If the installer asks you to allow access to the keychain, click **Deny**.



If you clicked **Always Allow** in this step, the **Select a wireless printer** window appears without asking for access to the keychain. If this occurs, click **Cancel** in the **Select a wireless printer** window.

10 On the **Select the Wireless Setup Method** screen, select **Using a USB cable**, and then click **Next**.

If the screen does not appear, go to step 14.

11 After searching, the window shows the wireless network devices. Select the name (SSID) of the access point you want to use and click **Next**.



When you set the wireless configuration manually, click **Advanced Setting**.

- **Enter the wireless Network Name:** Enter the SSID of the access point (SSID is case-sensitive).
- **Operation Mode:** Select **Infrastructure**.

Wireless network setup

- **Authentication:** Select an authentication type.
Open System: Authentication is not used, and encryption may or may not be used, depending on the need for data security.
Shared Key: Authentication is used. A device that has a proper WEP key can access the network.
WPA Personal or WPA2 Personal: Select this option to authenticate the print server based on the WPA Pre-Shared Key. This uses a shared secret key (generally called Pre Shared Key pass phrase) that is manually configured on the access point and each of its clients.
- **Encryption:** Select the encryption. (None, WEP64, WEP128, TKIP, AES)
- **Network Key:** Enter the encryption network key value.
- **Confirm Network Key:** Confirm the encryption network key value.
- **WEP Key Index:** If you are using WEP Encryption, select the appropriate **WEP Key Index**.

The wireless network security window appears when the access point has security enabled.

Enter the Network Key of the access point (or router).

- 12** The window showing the wireless network setting appears. Check the settings and click **Next**.



- You can start Wi-Fi Direct by using the control panel (see "Setting up Wi-Fi Direct" on page 180).
- **Wi-Fi Direct Name:** The default Wi-Fi Direct Name is the model name and the maximum length is 22 characters.
- **Password setting** is the numeric string, and the size is 8 ~ 64 characters.

- 13** The **Wireless Network Setting Complete** window appears. Click **Next**.
- 14** When the wireless network settings are completed, disconnect the USB cable between the computer and machine. Click **Next**.
- 15** Follow the instructions in the installation window.

Access point without a USB cable

Items to prepare

- WiFi-enabled Mac running Mac OS 10.7 or higher and an access point (router)
- Software CD that was provided with your machine
- A machine installed with a wireless network interface

- 1** Make sure that the machine is connected to your computer and powered on.
- 2** Insert the supplied software CD into your CD-ROM drive.
- 3** Select the CD-ROM volume that appears on **Finder**.
- 4** Double-click **Install Software** icon.
- 5** Read the license agreement and check installation agreement button.
- 6** Click **Next**.

Wireless network setup

- 7 Select **Wireless** on the **Printer Connection Type** screen.
- 8 Click **Next**.
- 9 If the installer asks you to allow access to the keychain, click **Allow**.
- 10 If the **Select a wireless printer** window appears, select the printer named DIRECT-xxx.



If the **Press WPS button on your printer** screen appears, press the  (WPS) button from the control panel within 2 minutes.

- 11 When the wireless network set up is complete, follow the instructions in the installation window.

Using a network cable



See your network administrator, or the person that set up your wireless network, for information about your network configuration.

Your machine is a network compatible machine. To enable your machine to work with your network, you will need to perform some configuration procedures.

Items to prepare

- Access point
- Network-connected computer
- Software CD that was provided with your machine
- A machine installed with a wireless network interface
- Network cable

Printing a network configuration report

You can identify the network settings of your machine by printing a network configuration report.

See "Printing a network configuration report" on page 157.

IP setting using SetIP Program (Windows)

This program is used to manually set the network IP address of your machine using its MAC address to communicate with the machine. The MAC address is the hardware serial number of the network interface and can be found in the **Network Configuration Report**.

See "Printing a network configuration report" on page 157.

Wireless network setup

Configuring the machine's wireless network

Before starting you will need to know the network name (SSID) of your wireless network and the network key if it is encrypted. This information was set when the access point (or wireless router) was installed. If you do not know about your wireless environment, please ask the person who set up your network.

To configure wireless parameters, you can use **SyncThru™ Web Service**.

Using SyncThru™ Web Service

Before starting wireless parameter configuration, check the cable connection status.

- 1 Check whether or not the network cable is connected to the machine. If not, connect the machine with a standard network cable.
- 2 Start a web browser such as Internet Explorer, Safari, or Firefox and enter your machine's new IP address in the browser window.

For example,



http://192.168.1.133/

- 3 Click **Login** on the upper right of the SyncThru™ Web Service website.

- 4 If it's your first time logging into **SyncThru™ Web Service** you need to log-in as an administrator. Type in the below default **ID** and **Password**. We recommend you to change the default password for security reasons.

•**ID: admin**

•**Password: sec00000**

- 5 When the **SyncThru™ Web Service** window opens, click **Network Settings**.

- 6 Click **Wi-Fi > Wizard**.

- 7 Select the one **Network Name(SSID)** in the list.

- 8 Click **Next**.

If the wireless security setting window appears, enter the registered password (network password) and click **Next**.

- 9 The confirmation window appears, please check your wireless setup. If the setup is right, click **Apply**.

Wireless network setup

Turning the Wi-Fi network on/off

- 1 Check whether the network cable is connected to the machine. If not, connect the machine with a standard network cable.
- 2 Start a web browser such as Internet Explorer, Safari, or Firefox and enter your machine's new IP address in the browser window.

For example,



- 3 Click **Login** on the upper right of the SyncThru™ Web Service website.
- 4 If it's your first time logging into **SyncThru™ Web Service** you need to log-in as an administrator. Type in the below default **ID** and **Password**. We recommend you to change the default password for security reasons.
•ID: admin
•Password: sec00000
- 5 When the **SyncThru™ Web Service** window opens, click **Network Settings**.
- 6 Click **Wi-Fi**.
- 7 You can turn the Wi-Fi network on/off.

Setting the Wi-Fi Direct for mobile printing

Wi-Fi Direct is a secure and easy-to-use peer-to-peer connection between a Wi-Fi Direct-enabled printer and mobile device.

With Wi-Fi Direct, you can connect your printer to a Wi-Fi Direct network while concurrently connecting to an access point. You can also use a wired network and a Wi-Fi Direct network simultaneously so multiple users can access and print documents both from Wi-Fi Direct and from a wired network.



- You cannot connect your mobile device to the internet through the printer's Wi-Fi Direct.
- The supported protocol list may differ from your model, Wi-Fi Direct networks do NOT support IPv6, network filtering, IPSec, WINS, and SLP services.
- The maximum number of devices that can be connected via Wi-Fi Direct is 4.

Setting up Wi-Fi Direct

You can enable Wi-Fi Direct feature by one of the following methods.

Wireless network setup

From the machine

- 1 Press the  (**Menu**) button on the control panel and select **Network > Wi-Fi > Wi-Fi Direct** from the display screen.
- 2 Tap **Wi-Fi Direct**.
- 3 Enable **Wi-Fi Direct**.

From the network-connected computer

If your printer is using a network cable or a wireless access point, you can enable and configure Wi-Fi Direct from SyncThru™ Web Service.

- 1 Access **SyncThru™ Web Service** and select **Settings > Network Settings > Wi-Fi > Wi-Fi Direct™**.
- 2 Enable **Wi-Fi Direct™** and set other options.

Setting up the mobile device

- After setting up Wi-Fi Direct from the printer, refer to the user manual of the mobile device you are using to set its Wi-Fi Direct.
- After setting up Wi-Fi Direct, you need to download the mobile printing application (For example: Samsung Mobile printer) to print from your smartphone.



- When you have found the printer you want to connect to from your mobile device, select the printer and the printer's LED will blink. Press the WPS button on the printer and it will be connected to your mobile device. If you don't have WPS button, press the option you want when the Wi-Fi connection confirmed window appears from the display screen and it will be connected to your mobile device.
- If your mobile device does not support Wi-Fi Direct, you need to enter the "Network Key" of a printer instead of pushing the WPS button.

Wireless network setup

Troubleshooting for wireless network

Problems during setup or driver installation

Printers Not Found

- Your machine may not be turned on. Turn on your computer and the machine.
- USB cable is not connected between your computer and machine. Connect the machine to your computer using the USB cable.
- The machine does not support wireless networking. Check the machine's user's guide included on the software CD supplied with your machine and prepare a wireless network machine.

Connecting Failure - SSID Not Found

- The machine is unable to find the network name (SSID) you have selected or entered. Check the network name (SSID) on your access point and try connecting again.
- Your access point is not turned on. Turn on your access point.

Connecting Failure - Invalid Security

- Security is not configured correctly. Check the configured security on your access point and machine.

Connecting Failure - General Connection Error

- Your computer is not receiving a signal from your machine. Check the USB cable and your machine's power.

Connecting Failure - Connected Wired Network

- Your machine is connected with a wired network cable. Remove the wired network cable from your machine.

Connecting Failure - Assigning the IP address

- Cycle the power for the access point (or wireless router) and machine.

PC Connection Error

- The configured network address is unable to connect between your computer and machine.
 - For a DHCP network environment
 - The receives the IP address automatically (DHCP) when computer is configured to DHCP.

Wireless network setup



If the printing job is not working in DHCP mode, the problem may be caused by the automatically changed IP address. Compare the IP address between the product's IP address and the printer port's IP address.

How to compare:

- 1 Print the network information report of your printer, and then check the IP address (see "Printing a network configuration report" on page 157).
- 2 Check the printer port's IP address from your computer.
 - a Click the Windows **Start** menu.
 - For Windows 8, from the **Charms**, select **Search > Settings**.
 - b For Windows XP Service Pack 3/Server 2003, select **Printer and Faxes**.
 - For Windows Server 2008/Vista, select **Control Panel > Hardware and Sound > Printers**.
 - For Windows Server 2008 R2, select **Control Panel > Hardware > Devices and Printers**.
 - For Windows 7/ Windows 8, select **Control Panel > Devices and Printers**.
 - c Right-click your machine.
 - d For Windows XP Service Pack 3/2003/2008/Vista, press **Properties**.
 - For Windows 7/ Windows 8 or Windows Server 2008 R2, from context menus, select the **Printer properties**.
 - If **Printer properties** item has ► mark, you can select other printer drivers connected with selected printer.
 - e Click **Port** tab.
 - f Click **Configure Port..** button.

- g Check if **Printer Name** or **IP Address:** is the IP address on the network configuration Sheet.
- 3 Change the printer port's IP address if it is different from the network information report's.
 - If you want to use the software installation CD to change the port IP, connect to a network printer. Then reconnect the IP address.

-For a Static network environment

The machine uses the static address when the computer is configured to static address.

For example,

If the computer's network information is as shown below:

- IP address: 169.254.133.42
- Subnet Mask: 255.255.0.0

Then the machine's network information should be as below:

- IP address: 169.254.133.**43**
- Subnet Mask: 255.255.0.0 (Use the computer's subnet mask.)
- Gateway: 169.254.133.**1**

Wireless network setup

Other problems

If problems occur while using the machine on a network, check the following:



For information on the access point (or wireless router), refer to its own user's guide.

- You cannot enable wired and wireless networks at the same time.
- Your computer, access point (or wireless router), or machine may not be turned on.
- Check the wireless reception around the machine. If the router is far from the machine or there is an obstacle, you might have difficulty receiving the signal.
- Cycle the power for the access point (or wireless router), machine, and computer. Sometimes cycling the power can recover network communication.
- Check whether firewall software (V3 or Norton) is blocking the communication.

If the computer and the machine are connected on the same network and it cannot be found when searching, firewall software might be blocking the communication. Refer to the user's guide for the software to turn it off and try searching for the machine again.

- Check whether the machine's IP address is allocated correctly. You can check the IP address by printing the network configuration report.

- Check whether the access point (or wireless router) has a configured security (password). If it has a password, refer to the access point (or wireless router) administrator.
- Check the machine's IP address. Reinstall the machine driver and change the settings to connect to the machine on the network. Due to the characteristics of DHCP, the allocated IP address could change if the machine is not used for a long time or if the access point has been reset.

Register the product's MAC address when you configure the DHCP server on the access point (or wireless router). Then you can always use the IP address that is set with the MAC address. You can identify the Mac address of your machine by printing a network configuration report (see "Printing a network configuration report" on page 157).

- Check the wireless environment. You might not be able to connect to the network in the infrastructure environment where you need to type in a user's information before connecting to the access point (or wireless router).
- This machine only supports IEEE 802.11 b/g/n and Wi-Fi. Other wireless communication types (e.g., Bluetooth) are not supported.
- You cannot use infrastructure mode at the same time for Samsung wireless network machines.
- The machine is within the range of the wireless network.
- The machine is located away from obstacles that could block the wireless signal.

Remove any large metal objects between the access point (or wireless router) and the machine.

Make sure the machine and wireless access point (or wireless router) are not separated by poles, walls, or support columns containing metal or concrete.

Wireless network setup

- The machine is located away from other electronic devices that may interfere with the wireless signal.

Many devices can interfere with the wireless signal, including a microwave oven and some Bluetooth devices.

- Whenever the configuration of your access point (or wireless router) changes, you must do the product's wireless network setup again.
- The maximum number of device that can be connected via **Wi-Fi Direct** is 3.
- If **Wi-Fi Direct** is **ON**, this machine only supports IEEE 802.11 b/g.
- If the access point is set to work with the 802.11n standard only, it may not connect to your machine.

Samsung Mobile Print

What is Samsung Mobile Print?

Samsung Mobile Print is a free application that enables users to print photos, documents, and web pages directly from your smartphone or tablet. **Samsung Mobile Print** is not only compatible with your Android and iOS smart phones but also with your iPod Touch and tablet PC. It connects your mobile device to a network connected Samsung printer or to a wireless printer through a Wi-Fi access point. Installing a new driver or configuring network settings isn't necessary – just simply install the **Samsung Mobile Print** application, and it will automatically detect compatible Samsung printers. Besides printing photos, web pages, and PDFs, scanning is also supported. If you have a Samsung multifunction, scan any document into a JPG, PDF, or PNG format for quick and easy viewing on your mobile device.

Downloading Samsung Mobile Print

To download **Samsung Mobile Print**, go to the application store (Samsung Apps, Play Store, App Store) on your mobile device, and just search for "**Samsung Mobile Print**". You can also visit iTunes for Apple devices on your computer.

- **Samsung Mobile Print**
 - Android:** Search for **Samsung Mobile Print** from Play Store, and then download the app.
 - iOS:** Search for **Samsung Mobile Print** from App Store, and then download the app.

Supported Mobile OS

- Android OS 2.3 or higher
- iOS 7.0 or higher

Using the NFC feature

The NFC (Near Field Communication) printer allows you to directly print/scan from your cell phone just by holding your cell phone over the NFC tag on your printer. It does not require installing print driver or connecting to an access point. You just need NFC supported cell phone. In order to use this feature, Samsung Mobile Print app needs to be installed on your cell phone.



- Depending on the material of the cell phone cover, NFC recognition may not work properly.
- Depending on the cell phone you are using, the transmission speed may differ.

Requirements

- NFC and Wi-Fi Direct enabled, Mobile Print app installed cell phone with Android OS 4.0 or higher.



Only Android OS 4.1 or higher will automatically enable the Wi-Fi Direct feature on your cell phone when you enable the NFC feature. We recommend you to upgrade your cell phone to Android OS 4.1 or higher to use the NFC feature.

- Wi-Fi Direct feature enabled printer. Wi-Fi Direct feature is enabled by default.

Printing

- 1 Check that NFC and Wi-Fi Direct features are enabled on your cell phone and Wi-Fi Direct feature is enabled on your printer (see "Setting the Wi-Fi Direct for mobile printing" on page 180).
- 2 Tag the NFC antenna on your cell phone (usually located on the back of the cell phone) over the NFC tag() on your printer.

Wait few seconds for Samsung Mobile Print app to start.

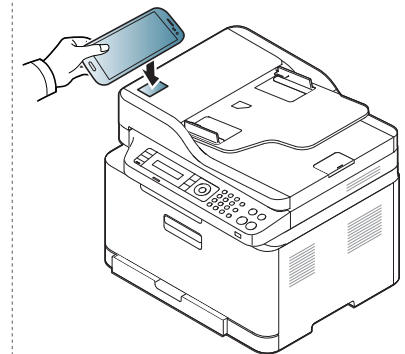
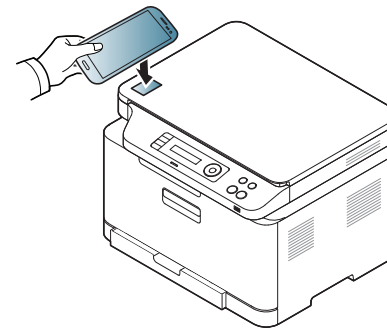

Using the NFC feature



- For some cell phones, NFC antenna might not be located at the back of the cell phone. Check the location of the NFC antenna on your cell phone before tagging.
- If error message about changed PIN number appears, enter a changed PIN number and press OK. Follow the instruction on the app screen to update the PIN number.
- If you do not have Samsung Mobile Print app installed on your cell phone, it automatically connects to Samsung Mobile Print app download page. Download the app and try again.



- For some cell phones, NFC antenna might not be located at the back of the cell phone. Check the location of the NFC antenna on your cell phone before tagging.
- If error message about changed PIN number appears, enter a changed PIN number and press OK. Follow the instruction on the app screen to update the PIN number.

3 Select the content you want to print.

If necessary, change the print option by pressing the .

4 Tag the NFC antenna on your cell phone(usually located on the back of the cell phone) over the NFC tag() on your printer.

Wait few seconds for the cell phone to connect to the printer.

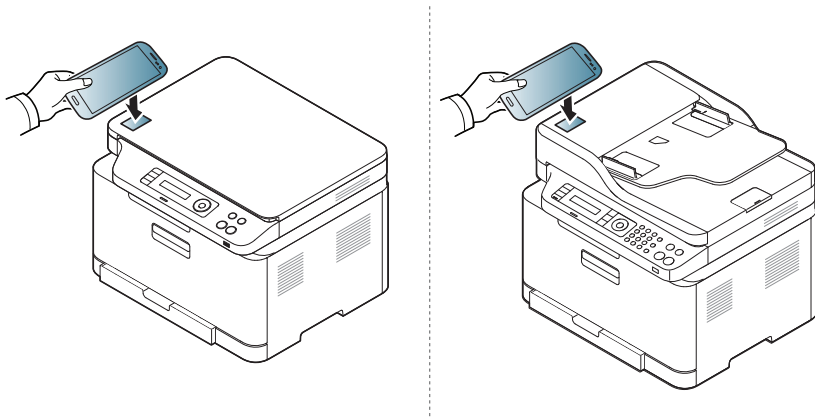

5 The printer starts printing.

Using the NFC feature

Scanning

- 1 Check that NFC and Wi-Fi Direct enabled features are on your cell phone and Wi-Fi Direct feature is enabled on your printer (see "Setting the Wi-Fi Direct for mobile printing" on page 180).
- 2 Tag the NFC antenna on your cell phone(usually located on the back of the cell phone) over the NFC tag() on your printer.

Wait few seconds for Samsung Mobile Print app to start.

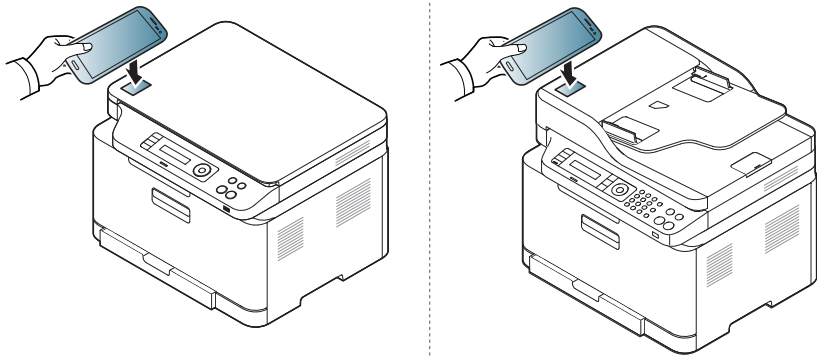

- For some cell phones, NFC antenna might not be located at the back of the cell phone. Check the location of the NFC antenna on your cell phone before tagging.
- If error message about changed PIN number appears, enter a changed PIN number and press OK. Follow the instruction on the app screen to update the PIN number.
- If you do not have Samsung Mobile Print app installed on your cell phone, it automatically connects to Samsung Mobile Print app download page. Download the app and try again.

- 3 Select scan mode.
- 4 Place a single document face down on the document glass, or load the documents face up into the document feeder (see "Loading originals" on page 50).

If necessary, change the scan option by pressing the .

Using the NFC feature

- 5 Tag the NFC antenna on your cell phone (usually located on the back of the cell phone) over the NFC tag () on your printer.

Wait a few seconds for the cell phone to connect to the printer.

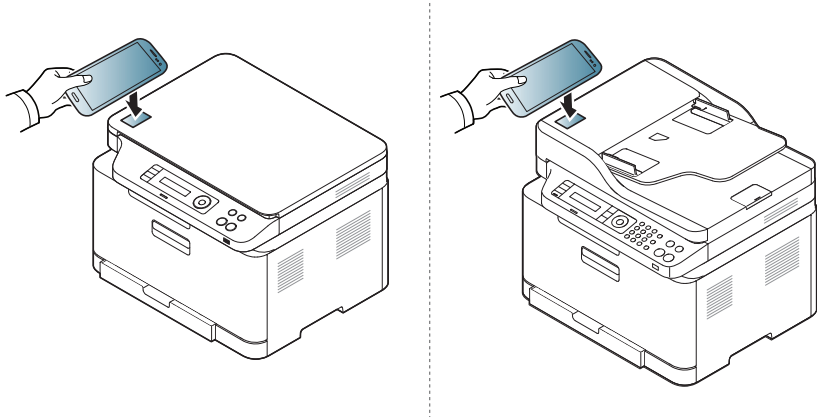

- For some cell phones, NFC antenna might not be located at the back of the cell phone. Check the location of the NFC antenna on your cell phone before tagging.
- If error message about changed PIN number appears, enter a changed PIN number and press OK. Follow the instruction on the app screen to update the PIN number.

- 6 The printer starts scanning the content.
The scanned data is saved on your cell phone.



If you want to continue scanning, follow the instruction on the app screen.

Sending Fax

- 1 Check that NFC and Wi-Fi Direct features are enabled on your mobile device and Wi-Fi Direct feature is enabled on your printer (see "Setting the Wi-Fi Direct for mobile printing" on page 180).
- 2 Tag the NFC tag on your mobile device (usually located on the back of the mobile device) over the NFC tag () on your printer.
Wait a few seconds for the **Samsung Mobile Print** app to start.

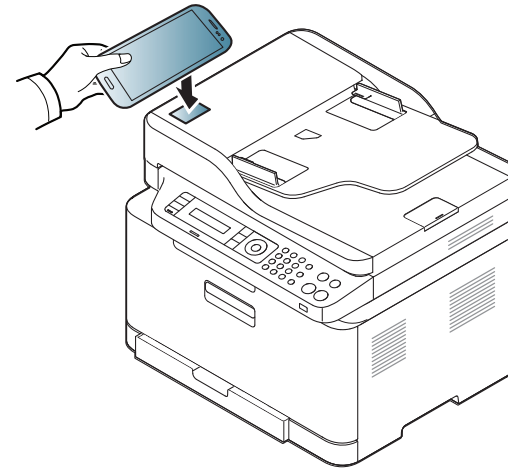

Using the NFC feature



- For some mobile devices, NFC tag might not be located at the back of the mobile device. Check the location of the NFC antenna on your mobile device before tagging.
- If error message about changed PIN number appears, enter a changed PIN number and press **OK**. Follow the instruction on the app screen to update the PIN number.
- If you do not have **Samsung Mobile Print** app installed on your mobile devices, it automatically connects to **Samsung Mobile Print** app download page. Download the app and try again.

3 Select fax mode.

4 Select the content you want to send fax.

If necessary, enter the fax number and change the fax option by pressing

the .

5 Tag the NFC tag on your mobile device (usually located on the back of the mobile device) over the NFC tag () on your printer.

Wait few seconds for the mobile device to connect to the printer.

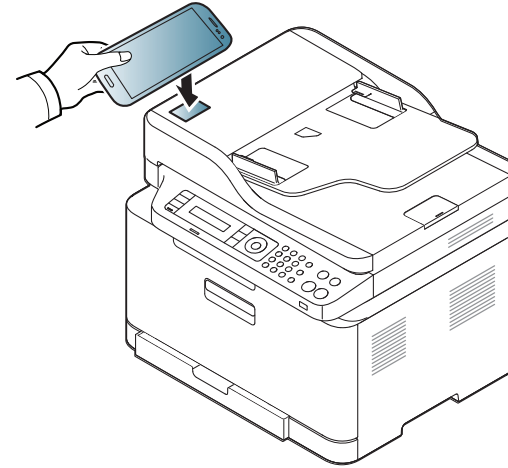

- For some mobile devices, NFC tag might not be located at the back of the mobile device. Check the location of the NFC antenna on your mobile device before tagging.
- If error message about changed PIN number appears, enter a changed PIN number and press **OK**. Follow the instruction on the app screen to update the PIN number.

6 The printer starts faxing the content.

Using the NFC feature

Registering Google Cloud Printer

- 1 Check that NFC and Wi-Fi Direct features are enabled on your mobile device and Wi-Fi Direct feature is enabled on your printer.
- 2 Tag the NFC tag on your mobile device (usually located on the back of the mobile device) over the NFC tag () on your printer.
Wait a few seconds for the **Samsung Mobile Print** app to start.

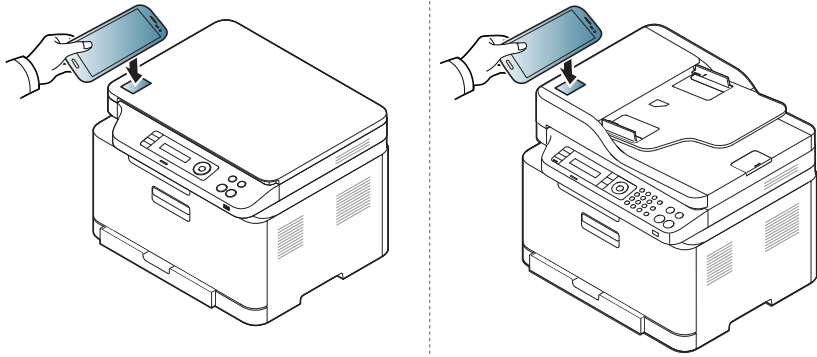

- For some mobile devices, NFC tag might not be located at the back of the mobile device. Check the location of the NFC antenna on your mobile device before tagging.
- If error message about changed PIN number appears, enter a changed PIN number and press **OK**. Follow the instruction on the app screen to update the PIN number.
- If you do not have **Samsung Mobile Print** app installed on your mobile devices, it automatically connects to **Samsung Mobile Print** app download page. Download the app and try again.

- 3 Select device status icon.
- 4 Select **Google Cloud Print > Register Google Cloud Printer**.
- 5 Tag the NFC tag on your mobile device (usually located on the back of the mobile device) over the NFC tag () on your printer.
Wait a few seconds for the mobile device to connect to the printer.

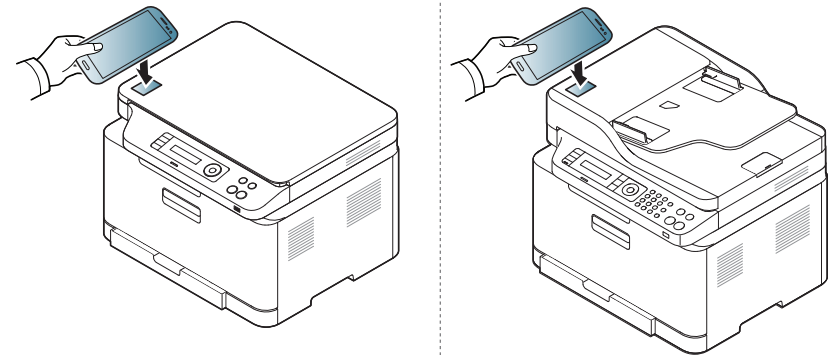

Using the NFC feature



- For some mobile devices, NFC tag might not be located at the back of the mobile device. Check the location of the NFC antenna on your mobile device before tagging.
- If error message about changed PIN number appears, enter a changed PIN number and press **OK**. Follow the instruction on the app screen to update the PIN number.

6 Confirm your printer in pop-up window.

Now your printer is registered with Google Cloud Print™ service



Only Mopria-certified machines can use the Mopria feature. Check the box that your machine came in for the Mopria-certified logo.



Mopria™ Print Service is a mobile printing solution that enhances the new print functionality on any Android phone or tablet (Android version 4.4 or later). With this service, you can connect and print to any Mopria-certified printer on the same network as your mobile device without additional set-up. Many native Android apps support printing, including Chrome, Gmail, Gallery, Drive and Quickoffice.

Setting up the machine for Mopria printing

Bonjour(mDNS) and IPP protocols are required on your machine to use the **Mopria** feature. Perform the following steps to enable the **Mopria** feature.

- 1 Ensure that the machine is connected to the network.
- 2 On your computer, open a web browser (Internet Explorer, Safari, or Firefox) and type the IP address of the machine in the address bar. Then, press Enter.

For example,



- 3 Click **Login** in the upper right corner of the SyncThru™ Web Service website.
- 4 Type in the **ID** and **Password**.



If you want to create a new user or change the password, see "Using SyncThru™ Web Service" on page 265.

- 5 When the SyncThru™ Web Service window opens, click **Settings** > **Network Settings** > **Standard TCP/IP, LPR, IPP** > **IPP**. Then, select **Enable**.
- 6 Click **Settings** > **Network Settings** > **mDNS**. Then, select **Enable**.
- 7 Click **Security** > **System Security** > **Feature Management** > **Mopria**. Then, select **Enable**.

Setting up Mopria on your mobile device

If you do not have **Mopria Print Service** app installed on your mobile device, open to the app store (Play Store, App Store) on your mobile device, search for **Mopria Print Service**, and then download and install the app.

- 1 In the **Settings** menu of your Android device, tap **Printing**.



The location of this option may differ depending on your mobile device. If you cannot locate the **Printing** option, refer to the user's manual for your mobile device.

- 2 Under **Print Services**, tap **Mopria Print Service**.
- 3 Tap the **On/Off** slider to enable the **Mopria Print Service**.

Printing via Mopria

To print via Mopria on an Android device:

- 1 Open the email, photo, web page, or document that you want to print.
- 2 Tap **Print** on the menu in the app.
- 3 Select **your printer**, and then configure the print options.
- 4 Touch **Print** again to print the document.



To cancel a print job: Select and delete the document from the print queue in the **Notification Bar**.

AirPrint



Only AirPrint certified machines can use the AirPrint feature. Check the box your machine came in for the AirPrint certified mark.



AirPrint allows you to wirelessly print directly from iPhone, iPad and iPod touch running the latest version of iOS.

Setting up AirPrint

Bonjour(mDNS) and IPP protocols are required on your machine to use the **AirPrint** feature. You can enable the **AirPrint** feature by one of the following methods.

- 1 Check whether the machine is connected to the network.
- 2 Start a web browser such as Internet Explorer, Safari, or Firefox and enter your machine's new IP address in the browser window.

For example,

A screenshot of a web browser address bar showing the URL "http://192.168.1.133/".

http://192.168.1.133/

- 3 Click **Login** in the upper right of the SyncThru™ Web Service website.

- 4 If it's your first time logging into **SyncThru™ Web Service** you need to log-in as an administrator. Type in the below default **ID** and **Password**. We recommend you to change the default password for security reasons.

•**ID: admin**

•**Password: sec00000**

- 5 When the **Embedded Web Service** window opens, click **Settings > Network Settings**.

- 6 Click **Raw TCP/IP, LPR, IPP** or **mDNS**.

You can enable the IPP protocol or mDNS protocol.

AirPrint

Printing via AirPrint

For example, the iPad manual provides these instructions:

- 1 Open your email, photo, web page, or document you want to print.
- 2 Touch the action icon().
- 3 Select **your printer driver name** and option menu to set up.
- 4 Touch **Print** button. Print it out.



Cancelling print job: To cancel the printing job or view the print summary, click the print center icon () in multitasking area. You can click cancel in the print center.

Samsung Cloud Print

Samsung Cloud Print is a free cloud service that allows you to print or scan from your smartphone or tablet to your Samsung printer or MFP. After installing the Samsung Cloud Print app, you can register with the Samsung Cloud Print service just using your mobile number for authentication. No other account login is required, although you can link the app to your Samsung Account if you wish.



If you press the () button from Samsung Cloud Print app, Your mobile device and printer or MFP can be paired , QR code, or by manually entering its MAC address. Once paired, you can print or scan from anywhere and everywhere.

Registering your Printer to Samsung Cloud server

Registering from Web Browser



Make sure the printer machine is turned on and connected to a wired or wireless network that has access to the Internet.

- 1 Open Web browser.
- 2 Enter your printer's IP address in the address field and press the Enter key or click **Go**.

- 3 Click **Login** in the upper right corner of the SyncThru™ Web Service website.
- 4 If it's your first time logging into **SyncThru™ Web Service** you need to log-in as an administrator. Type in the below default **ID** and **Password**. We recommend you to change the default password for security reasons.

•**ID: admin**

•**Password: sec00000**



If you want to create a new user or change the password, see "Security tab" on page 266.

- 5 When the **SyncThru™ Web Service** window opens, click **Settings** > **Network Settings** > **Samsung Cloud Print**.
- 6 Enable Samsung Cloud Print Protocol.
- 7 Now your printer is registered with Samsung Cloud Print service.

Samsung Cloud Print

Printing with Samsung Cloud Print



Make sure the printer is turned on and connected to a wired or wireless network that has access to the Internet.

Registering a printer from an application on mobile device

The following steps are an example of using the **Samsung Cloud Print** app from Android mobile phone.

- 1 Open **Samsung Cloud Print** app.



If you do not have **Samsung Cloud Print** app installed on your cellphone, go to the application store (Samsung Apps, Play Store, App Store) on your mobile device, and just search for download the app and try again.

- 2 Press the () button from Samsung Cloud Print app.
- 3 Your mobile device and printer or MFP can be paired NFC tapping, QR code or by manually entering its MAC address.

Printing from an application on mobile device

The following steps are an example of using the **Samsung Cloud Print** app from Android mobile phone.

- 1 Open **Samsung Cloud Print** app.



If you do not have **Samsung Cloud Print** app installed on your cellphone, go to the application store (Samsung Apps, Play Store, App Store) on your mobile device, and just search for download the app and try again.

- 2 Tap the option check button of the document that you want to print.
- 3 Set the printing options if you want.
- 4 Tap **Send Job**.

Scanning and sending to Samsung Cloud Print

You can scan an image and the scanned data will be stored in the **Samsung Cloud Print**.

- 1 Place a single document face down on the document glass, or load the documents face up into the document feeder (see "Loading originals" on page 50).
- 2 Press  (scan) on the control panel.

Samsung Cloud Print

- 3 Press **Samsung Cloud**.
- 4 Enter recipient country code and recipient phone number.
- 5 Enter sender information.
- 6 Press the  (**Start**) button to scan and store the file in samsung cloud server.



When the user is not registered in the **Samsung Cloud Print**, a confirmation window will pop up. Select a work in progress or not.

Google Cloud Print™

Google Cloud Print™ is a service that allows you to print to a printer using your smart phone, tablet, or any other web-connected devices. Just register your Google account with the printer, and you are ready to use the Google Cloud Print service. You can print your document or email with Chrome OS, Chrome browser, or a Gmail™/ Google Docs™ application on your mobile device, so you don't need to install the printer driver on the mobile device. Refer to the Google website (<http://support.google.com/cloudprint>) for more information about Google Cloud Print.

Registering your Google account to the printer



- Make sure the printer machine is turned on and connected to a wired or wireless network that has access to the Internet.
- You should create your Google account in the advance.

- 1 Open the Chrome browser.
- 2 Visit www.google.com.
- 3 Sign in to the Google website with your Gmail address.
- 4 Enter your printer's IP address in the address field and press the Enter key or click **Go**.

5 Click **Login** in the upper right corner of the SyncThru™ Web Service website.

6 If it's your first time logging into **SyncThru™ Web Service** you need to log-in as an administrator. Type in the below default **ID** and **Password**. We recommend you to change the default password for security reasons.

•**ID: admin**

•**Password: sec00000**



If the network environment is using a proxy server, you need to configure the proxy's IP and port number from **Settings > Network Settings > Google Cloud Print > Proxy Setting**. Contact your network service provider or network administrator for more information.

7 When the **SyncThru™ Web Service** window opens, click **Settings > Network Settings > Google Cloud Print**.

8 Enter your printer's name and description.

9 Click **Register**.
The confirmation pop-up window appears.



If you set the browser to block pop-ups, the confirmation window will not appear. Allow the site to show pop-ups.

Google Cloud Print™

10 Click **Finish printer registration**.

11 Click **Manage your printers**.

Now your printer is registered with Google Cloud Print service.

Google Cloud Print-ready devices will appear in the list.

Printing with Google Cloud Print™

The printing procedure varies depending on the application or the device you are using. You can see the application list that supports Google Cloud Print service.



Make sure the printer is turned on and connected to a wired or wireless network that has access to the Internet.

Printing from an application on mobile device

The following steps are an example of using the Google Docs app from Android mobile phone.

1 Install the Cloud Print application on your mobile device.



If you do not have the application, download it from the application store such as Android Market or App Store.

2 Access the Google Docs application from your mobile device.

3 Tap the option  button of the document that you want to print.

4 Tap the send  button.

5 Tap the Cloud Print  button.

6 Set the printing options if you want.

7 Tap **Click here to Print**.

Printing from the Chrome browser

The following steps are an example of using the Chrome browser.

- 1 Run Chrome.
- 2 Open the document or email that you want to print.
- 3 Click the wrench icon  in the browser's top right corner.
- 4 Click **Print**. A new tab for printing appears.
- 5 Select **Print with Google Cloud Print**.
- 6 Click the **Print** button.



3. Useful Setting Menus

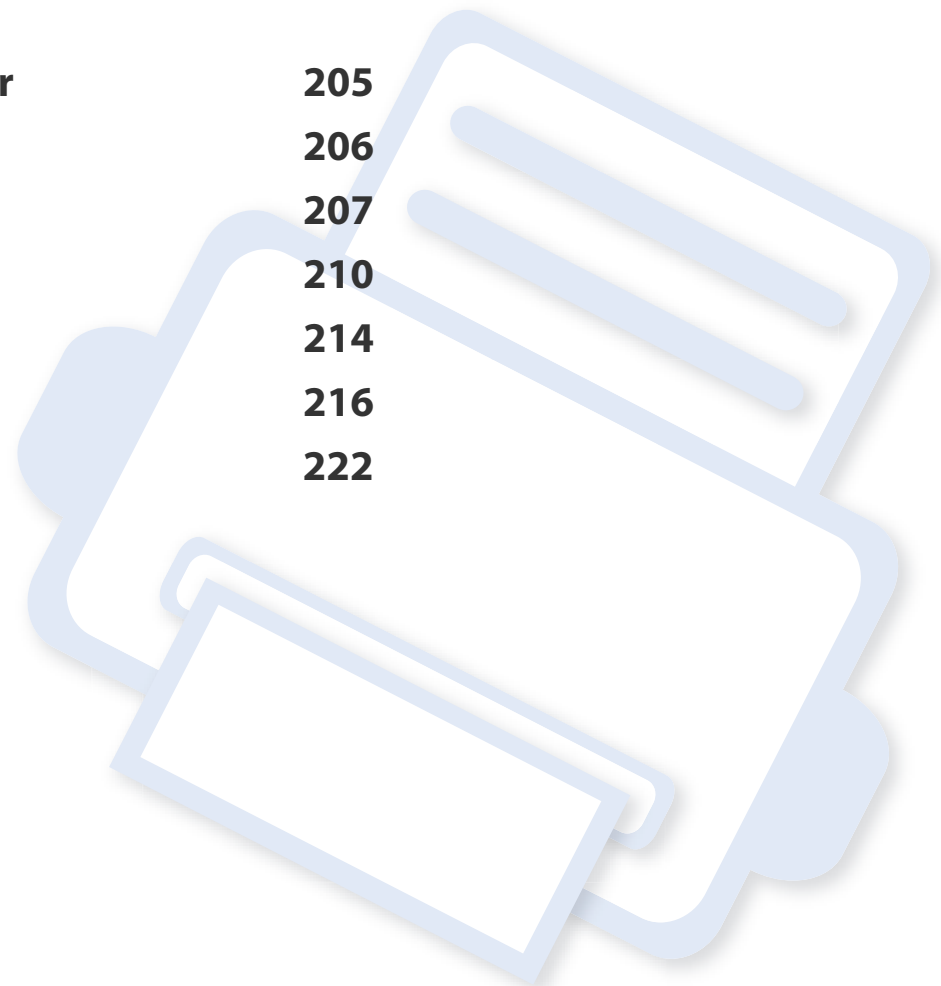

This chapter explains how to browse the current status of your machine, and the method of setting for advanced machine setup.

- **Before you begin reading a chapter** 205
- **Print** 206
- **Copy** 207
- **Fax** 210
- **Scan** 214
- **System setup** 216
- **Network setup** 222



Before you begin reading a chapter

This chapter explains all the features available for this series' models to help users easily understand the features. You can check the features available for each model in the Basic Guide (see "Menu overview" on page 34). The following are tips for using this chapter

- The control panel provides access to various menus to set up the machine or use the machine's functions. These menus can be accessed by pressing  (**Menu**).
- Some menus may not appear on the display depending on options or models. If so, it is not applicable to your machine.
- For models that do not have the  (**Menu**) on the control panel, this feature is not applicable (see "Control panel overview" on page 24).
- Some menu names may differ from your machine depending on its options or the models.



Some menus may not appear in the display depending on options or models. If so, it is not applicable to your machine (see "Menu overview" on page 34).

To change the menu options:

- Press  (**Menu**) > **Print Setup** on the control panel.

| Item | Description |
|--------------------|---|
| Orientation | Selects the direction in which information is printed on a page. |
| Copies | You can enter the number of copies using the number keypad. |
| Resolution | Specifies the number of dots printed per inch (dpi). The higher the setting, the sharper printed characters and graphics. |
| Trapping | Reduces the white gap caused by misalignment of color channels in color printing mode. Also black text will be overprinted on other colors. |

| Item | Description |
|-----------------------|--|
| Screen | Affects the resolution and clarity of your color output. <ul style="list-style-type: none">• Enhanced: This mode will generate printouts with sharp texts and smooth graphic/photo objects in the page.• Detailed: This mode will generate printouts with sharp details over the entire page.• Normal: This mode will generate printouts with smooth tone over the entire page. |
| Clear Text | Selects this option to print texts clearer than on a normal document. |
| Auto CR | Allows you to append the required carriage return to each line feed, which is useful for Unix or DOS users. |
| Emulation | Sets the emulation type and option. |
| Edge Enhance | Allows user to enhance sharpness of text and graphics for improving readability. |
| Darkness | You can adjust the degree of darkness. This feature allows dark images to be printed into lighter images, or light images into darker images. |
| SkipBlankPages | This option allows you to specify not to print blank pages in the original data. |

Copy

Copy feature



Some menus may not appear in the display depending on options or models. If so, it is not applicable to your machine (see "Menu overview" on page 34).



To change the menu options:

In copy mode, press  (**Menu**) > **Copy Feature** on the control panel.

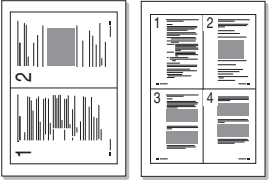

- **C48xW series:** When the **Scan to** button's LED is off, the machine is in copy mode.
- **C48xFN/C48xFW series:** Press  (copy) on the control panel.

| Item | Description |
|-----------------------|---|
| Original Size | Sets the image size. |
| Reduce/Enlarge | <p>Reduces or enlarges the size of a copied image (see "Reduced or enlarged copy" on page 61).</p> <div style="border: 1px solid #ccc; padding: 5px; margin-top: 10px;">  If the machine is set to Eco mode, reduce and enlarge features are not available. </div> |

| Item | Description |
|---|--|
| Darkness | Adjusts the brightness level to make a copy that is easier to read, when the original contains faint markings and dark images (see "Darkness" on page 60) |
| Original Type | Improves the copy quality by selecting the document type for the current copy job (see "Original" on page 61) |
| Collation | Set the machine to sort the copy job. For example, if you make 2 copies of a 3 page original, one complete 3 page document will print followed by a second complete document. |
| Layout | Adjusts the layout format such as Normal, ID copy, 2/4-up. |
| Layout > 2-up or Layout > 4-up | <p>Reduces the size of the original images and prints 2 or 4 pages onto one sheet of paper.</p> <div style="text-align: center; margin: 10px 0;">  </div> <div style="border: 1px solid #ccc; padding: 5px; margin-top: 10px;">  This copy feature is available only when you load originals into the document feeder. </div> |

Copy

| Item | Description |
|----------------------------|--|
| Layout > ID Copy | prints one side of the original on the upper half of the paper and the other side on the lower half without reducing the size of the original. This feature is helpful for copying a small-sized item such as business card. |
| Adjust Bkgd. | <p>Prints an image without its background. This copy feature removes the background color and can be helpful when copying an original containing color in the background, such as a newspaper or a catalog.</p> <ul style="list-style-type: none">• Off: Does not use this feature.• Auto: Optimizes the background.• Enhance Lev.1~2: The higher the number is, the more vivid the background is.• Erase Lev.1~4: The higher the number is, the lighter the background is. |

Copy Setup



Some menus may not appear in the display depending on options or models. If so, it is not applicable to your machine (see "Menu overview" on page 34).

To change the menu options:



In copy mode, press  (**Menu**) > **Copy Setup** on the control panel.



- **C48xW series:** When the **Scan to** button's LED is off, the machine is in copy mode.
- **C48xFN/C48xFW series:** Press  (copy) on the control panel.

| Item | Description |
|--|--|
| Change Default | Resets the value or setting to the printer's out-of-box state. |
| Change Default > Original Size | Improves the copy quality by selecting the document size for the current copy job. |
| Change Default > Copies | You can enter the number of copies using the number keypad. |

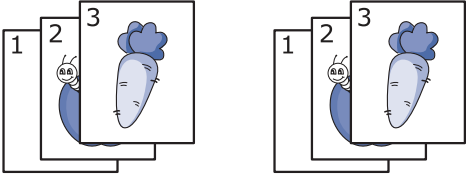
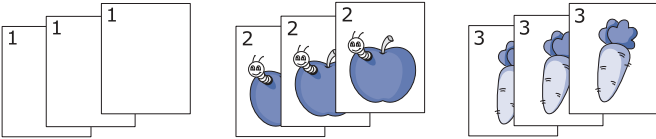
Copy

| Item | Description |
|--|---|
| <p>Change Default > Collation</p> | <p>Set the machine to sort the copy job. For example, if you make 2 copies of a 3 page original, one complete 3 page document will print followed by a second complete document.</p> <ul style="list-style-type: none"> • On: Prints output in sets to match the sequence of originals.  <ul style="list-style-type: none"> • Off: Prints output sorted into stacks of individual pages.  |
| <p>Change Default > Reduce/Enlarge</p> | <p>Reduces or enlarges the size of a copied image (see "Reduced or enlarged copy" on page 61).</p> <div data-bbox="383 1163 1081 1321" style="background-color: #f0f0f0; padding: 10px;">  <p>If the machine is set Eco mode, reduce and enlarge features are not available.</p> </div> |

| Item | Description |
|---|--|
| <p>Change Default > Darkness</p> | <p>Adjusts the brightness level to make a copy that is easier to read, when the original contains faint markings and dark images (see "Darkness" on page 60)</p> |
| <p>Change Default > Original Type</p> | <p>Improves the copy quality by selecting the document type for the current copy job (see "Original" on page 61)</p> |

Fax Feature



Some menus may not appear in the display depending on options or models. If so, it is not applicable to your machine (see "Menu overview" on page 34).

To change the menu options:

- Press (fax) > (Menu) > **Fax Feature** on the control panel.

| Item | Description |
|----------------------|---|
| Darkness | Adjusts the brightness level to scan an original that is easier to read, when the original contains faint markings and dark images (see "Darkness" on page 68). |
| Resolution | The default document settings produce good results when using typical text-based originals. However, if you send originals that are of poor quality, or contain photographs, you can adjust the resolution to produce a higher quality fax (see "Resolution" on page 67). |
| Original Size | Sets the image size. |

| Item | Description |
|-----------------------|---|
| Multi Send | <p>Sends a fax to multiple destinations (see "Sending a fax to multiple destinations" on page 66).</p> <p> You cannot send a color fax using this feature.</p> |
| Delay Send | <p>Sets your machine to send a fax at a later time when you will not be present (see "Delaying a fax transmission" on page 251).</p> <p> You cannot send a color fax using this feature.</p> |
| Send Forward | Forwards the sent fax to other destination. See "Forwarding a sent fax to another destination" on page 252. |
| Rcv. Forward | Forwards the received fax to other destination. If you are out of office but have to receive the fax, this feature may be useful. See "Forwarding a received fax" on page 252. |
| Secure Receive | Stores the received fax in memory without printing out. To print received documents, you need to enter the password. You can prevent your received faxes from being accessed by unauthorized people (see "Receiving in secure receiving mode" on page 255). |
| Cancel Job | Cancels the delayed fax job which is saved in memory (see "Canceling a reserved fax job" on page 251). |

Sending setup



Some menus may not appear in the display depending on options or models. If so, it is not applicable to your machine (see "Menu overview" on page 34).

To change the menu options:

- Press (fax) > (Menu) > **Fax Setup** > **Sending** on the control panel.

| Item | Description |
|---------------------|--|
| Redial Times | Sets the number of redial attempts. If you enter 0, the machine will not redial. |
| Redial Term | Sets the time interval before automatic redialling. |
| Prefix Dial | Sets a prefix of up to five digits. This number dials before any automatic dial number is started. It is useful for accessing a PABX exchange. |
| ECM Mode | Sends faxes using error correction mode (ECM) to make sure the faxes are sent smoothly without any error. It may take more time. |

| Item | Description |
|---------------------|--|
| Fax Confirm. | Sets the machine to print a report whether a fax transmission was successfully completed or not. If you select On-Error , the machine prints a report only when a transmission is not successful. |
| Modem speed | Select the maximum modem speed you want if the phone line fails to sustain a higher modem speed. |
| Image TCR | Prints a transmission report with a minimized image of the first page of the fax sent. |
| Dial Mode | Sets the dialing mode to either tone or pulse. This setting may not be available depending on your country. |

Receiving setup



Some menus may not appear in the display depending on options or models. If so, it is not applicable to your machine (see "Menu overview" on page 34).

To change the menu options:

- Press  (fax) >  (Menu) > **Fax Setup** > **Receiving** on the control panel.

| Item | Description |
|-----------------------|--|
| Receive Mode | Selects the default fax receiving mode. |
| Ring To Answer | Specifies the number of times the machine rings before answering an incoming call. |
| Stamp Rcv Name | Automatically prints the page number, and the date and time of reception at the bottom of each page of a received fax. |
| Rcv Start Code | Initiates fax reception from an extension phone plugged into the EXT socket on the back of the machine. If you pick up the extension phone and hear fax tones, enter the code. It is preset to *9* at the factory. |

| Item | Description |
|-----------------------|---|
| Auto Reduction | Automatically reduces an incoming fax page to fit the size of the paper loaded in the machine. |
| Discard Size | Discards a specific length from the end of the received fax. |
| Junk Fax Setup | Blocks any unwanted faxes that you stored in the memory as junk fax numbers. This setting may not be available depending on your country. |
| DRPD Mode | Enables a user to use a single telephone line to answer several different telephone numbers. You can set the machine to recognize different ring patterns for each number. This setting may not be available depending on your country (see "Receiving faxes using DRPD mode" on page 255). |

Another setup



Some menus may not appear in the display depending on options or models. If so, it is not applicable to your machine (see "Menu overview" on page 34).

To change the menu options:

- Press (fax) > (**Menu**) > **Fax Setup** on the control panel.

| Item | Description |
|-----------------------|---|
| Change Default | Resets the value or setting to the printer's out-of-box state. |
| Smart Fax Diag | The Smart Fax Diag feature optimizes the settings for your fax line. |
| Manual TX/RX | Setting this option to ON provides the ability to send or receive a fax while the line is busy. You can select to send or receive a fax by either picking up the extension phone receiver and pressing the Start button or by pressing the On Hook Dial button and pressing the Start button. |

Scan

Scan feature



Some menus may not appear in the display depending on options or models. If so, it is not applicable to your machine (see "Menu overview" on page 34).

To change the menu options:

in scan mode, press  (**Menu**) > **Scan Feature** on the control panel.



- **C48xW series:** When the **Scan to** button's LED is on, the machine is in scan mode.
- **C48xFN/C48xFW series:** Press  (scan) on the control panel.

| Item | Description |
|---|--|
| USB Feature | Sets scan destination to a USB. You scan the originals and save the scanned image to a USB device. |
| <ul style="list-style-type: none"> • USB Feature > Original Size • Email Feature > Original Size • Samsung Cloud > Original Size | Sets the image size. |

| Item | Description |
|---|---|
| <ul style="list-style-type: none"> • USB Feature > Original Type • Email Feature > Original Type • Samsung Cloud > Original Type | Sets the original document's type. |
| <ul style="list-style-type: none"> • USB Feature > Resolution • Email Feature > Resolution • Samsung Cloud > Resolution | Sets the image resolution. |
| <ul style="list-style-type: none"> • USB Feature > Color Mode • Email Feature > Color Mode • Samsung Cloud > Color Mode | Sets the color mode. |
| <ul style="list-style-type: none"> • USB Feature > Darkness • Email Feature > Darkness • Samsung Cloud > Darkness | Adjusts the brightness level to scan. |
| USB Feature > File Format | Sets the file format in which the image is to be saved. If you select JPEG, TIFF, PDF, or XPS, you can select to scan multiple pages. |

Scan

Scan setup



Some menus may not appear in the display depending on options or models. If so, it is not applicable to your machine (see "Menu overview" on page 34).

To change the menu options:

In scan mode, press  (**Menu**) > **Scan Setup** on the control panel.



- **C48xW series:** When the **Scan to** button's LED is on, the machine is in scan mode.
- **C48xFN/C48xFW series:** Press  (scan) on the control panel.

| Item | Description |
|--|--|
| Change Default | Resets the value or setting to the printer's out-of-box state. |
| Change Default > USB Default | Resets the USB scan setting to the printer's out-of-box state. |
| Change Default > Email Default | Resets the Email scan setting to the printer's out-of-box state. |

| Item | Description |
|--|---|
| Change Default > Samsung Cloud | Resets the Samsung Cloud scan setting to the printer's out-of-box state. |

System setup

Machine setup



Some menus may not appear in the display depending on options or models. If so, it is not applicable to your machine (see "Menu overview" on page 34).

To change the menu options:

- Press  (**Menu**) > **System Setup** > **Machine Setup** on the control panel.

| Item | Description |
|------------------------|--|
| Machine ID | Sets the machine ID which will be printed at the top of each fax page that you send. |
| Fax Number | Sets the fax number which will be printed at the top of each fax page that you send. |
| Date & Time | Sets the date and time. |
| Clock Mode | Selects the format for displaying time between 12 hr. and 24 hr. |
| Language | Sets the language of the text that appears on the control panel display. |
| Default Mode | Sets the default status. |

| Item | Description |
|-----------------------|---|
| Power Save | <p>Sets how long the machine waits before going to power save mode.</p> <p>When the machine does not receive data for an extended period of time, power consumption is automatically lowered.</p> |
| Auto Power Off | <p>Turns power off automatically when the machine has been in power save mode for the length of time set in Auto Power Off > On > Timeout.</p> <div data-bbox="1473 707 1536 767"></div> <ul style="list-style-type: none">This option only appears in the C48x/C48xW series.To turn the machine on again, press the  (Power/Wake Up) button on the control panel (make sure the main power switch is on).If you run the printer driver or Samsung Easy Printer Manager, the time automatically extends.The Auto Power Off feature is disabled if the machine is connected to a wireless or wired network or working on a print job. |

System setup

| Item | Description |
|-----------------------|---|
| Wakeup Event | <p>You can set the condition to wake up from power-save mode.</p> <ul style="list-style-type: none">• On: The machine wake up from the power save mode on the following cases:<ul style="list-style-type: none">- Pressing any button- Opening or closing the paper tray- Inserting paper in the document feeder• Off: The machine wakes up from power save mode only when a button on the control panel is pressed. |
| System Timeout | <p>Sets the time that the machine remembers previously used copy settings. After the timeout, the machine restores the default copy settings.</p> |
| Job Timeout | <p>Sets the length of time the printer waits before printing the last page of a print job that does not end with a command to print the page.</p> |
| Altitude Adj. | <p>Optimize print quality according to the machine's altitude.</p> |
| Humidity | <p>Optimizes print quality according to the humidity in the environment.</p> |

| Item | Description |
|-----------------------|---|
| Auto Continue | <p>Determine whether or not the machine continues printing when it detects the paper does not match the paper settings.</p> <ul style="list-style-type: none">• Off: If a paper mismatch occurs, the machine waits until you insert the correct paper.• After 0 Sec: Even though a paper mismatch occurs, the machine continues printing.• After 30 Sec: If a paper mismatch occurs, an error message will display. The machine waits for about 30 second, then automatically clear the message and continue printing. |
| Paper Substit. | <p>Automatically substitutes the printer driver's paper size to prevent the paper mismatch between Letter and A4. For example, if you have A4 paper in the tray but you set the paper size to Letter in the printer driver, the machine prints on A4 paper and vice versa.</p> |

System setup

| Item | Description |
|---------------------|---|
| Eco Settings | <p>Allows you to save print resources and enables eco-friendly printing.</p> <ul style="list-style-type: none">• Default Mode: Select whether to turn the Eco mode on or off. <p> On force (On-Forced): Sets the Eco mode on with password. If a user wants to turn the Eco mode on/off, the user needs to enter the password.</p> <ul style="list-style-type: none">• Select Temp.: Selects the eco template set from the SyncThru™ Web Service. |

Paper setup



Some menus may not appear in the display depending on options or models. If so, it is not applicable to your machine (see "Menu overview" on page 34).

To change the menu options:

- Press  (**Menu**) > **System Setup** > **Paper Setup** on the control panel.

| Item | Description |
|-------------------|--|
| Paper Size | Sets the paper size as A4, Letter, or other paper sizes, according to your requirements. |
| Paper Type | Chooses the type of the paper for each tray. |
| Margin | Sets the margins for the document. |

System setup

Sound / Volume





Some menus may not appear in the display depending on options or models. If so, it is not applicable to your machine (see "Menu overview" on page 34).

To change the menu options:

- Press  (**Menu**) > **System Setup** > **Sound/Volume** on the control panel.

| Item | Description |
|--------------------|---|
| Key Sound | Turns the key sound on or off. With this option set to on, a tone sounds each time a key is pressed. |
| Alarm Sound | Turns the alarm sound on or off. With this option set to on, an alarm tone sounds when an error occurs or fax communication ends. |

| Item | Description |
|----------------|---|
| Speaker | <p>Turns on or off the sounds from the telephone line through the speaker, such as a dial tone or a fax tone. With this option set to Comm. which means the speaker is on until the remote machine answers.</p> <p> You can adjust the volume level using On Hook Dial. You can adjust the speaker volume only when the telephone line is connected.</p> <ol style="list-style-type: none">Press  (fax) on the control panel.Press On Hook Dial. A dial tone sounds from the speaker.Press the arrows until you hear the volume you want.Press On Hook Dial to save the change and return to ready mode. |
| Ringer | Adjusts the ringer volume. For the ringer volume, you can select off, low, middle, and high level. |

System setup

Report



Some menus may not appear in the display depending on options or models. If so, it is not applicable to your machine (see "Menu overview" on page 34).

To change the menu options:

- Press  (**Menu**) > **System Setup** > **Report** on the control panel.

| Item | Description |
|-----------------------|---|
| Configuration | Prints a report on the machine's overall configuration. |
| Supplies Info. | Prints supplies' information page. |
| Demo Page | Prints the demo page to check whether your machine is printing properly or not. |
| Address Book | Prints all of the fax number currently stored in the machine's memory. |
| Fax Confirm. | Prints a transmission report including the fax number, the number of pages, the elapsed time of the job, the communication mode, and the communication results for fax job. You can set up your machine to automatically print a transmission confirmation report after each fax job. |

| Item | Description |
|-----------------------|--|
| Email Sent | Print to check the transmission state of the Scan to Email job. |
| Fax Sent | Prints information on the faxes you have recently sent. |
| Fax Received | Prints information on the faxes you have recently received. |
| Scheduled Jobs | Prints the document list currently stored for delayed faxes along with the starting time and type of each operation. |
| Junk Fax | Prints the fax numbers specified as junk fax numbers. |
| PCL Font | Print to see the PCL font list. |
| PS Font | Print to see the PS font list |
| Network Conf. | Prints information on your machine's network connection and configuration. |
| Usage Counter | Prints a usage page. The usage page contains the total number of pages printed. |

System setup

Maintenance



Some menus may not appear in the display depending on options or models. If so, it is not applicable to your machine (see "Menu overview" on page 34).

To change the menu options:

- Press  (**Menu**) > **System Setup** > **Maintenance** on the control panel.

| Item | Description |
|----------------------|--|
| CLR Empty Msg | When toner cartridge is empty, this option appears. You can clear the empty message. |
| Supplies Life | Shows the supply life indicators (see "Monitoring the supplies life" on page 93.) |
| Image Mgr. | Allows you to adjust the color setting such as contrast level, color registration, color density, etc. <ul style="list-style-type: none">• Custom Color: adjusts contrast, color by color.<ul style="list-style-type: none">- Default: optimizes colors automatically.- Print Density: allows you to manually adjust the color contrast for each cartridge. It is recommended to use the Default setting for best color quality. |

| Item | Description |
|-----------------------|---|
| Serial Number | Shows the machine's serial number. When you call for service or register as a user on the Samsung website, you can find this. |
| TonerLow Alert | Customizes the level to alert toner low or toner empty (see "Setting the toner low alert" on page 94). |
| ImgU.Low Alert | Customizes the level to alert imaging unit low. |

Network setup





Some menus may not appear in the display depending on options or models. If so, it is not applicable to your machine (see "Menu overview" on page 34).

- Press (**Menu**) > **Network** on the control panel.

| Option | Description |
|-----------------------|---|
| TCP/IP (IPv4) | <p>Selects the appropriate protocol and configure parameters to use the network environment.</p> <div data-bbox="358 718 1075 925"> There are many of parameters to be set. If you are not sure, leave as is, or consult the network administrator. </div> |
| TCP/IP (IPv6) | Selects this option to use the network environment through IPv6 (see "IPv6 configuration" on page 165). |
| Ethernet | Configure the network transmission speed and active port. |
| Wi-Fi | Selects this option to use the Wi-Fi network. |
| Clear Settings | Reverts the network settings to the default values. (Reboot required.) |
| Network Conf. | This list shows information on your machine's network connection and configuration. |

| Option | Description |
|----------------------|--|
| Protocol Mgr. | <p>You can activate or deactivate the following protocols.</p> <ul style="list-style-type: none"> HTTP: You can set whether to use SyncThru™ Web Service or not. |
| | <div data-bbox="1456 446 2195 606"> Turn the power off and on after you change this option. </div> |
| | <ul style="list-style-type: none"> WINS: You can configure the WINS server. WINS(Windows Internet Name Service) is used in the Windows operating system. |
| | <div data-bbox="1456 782 2195 941"> Turn the power off and on after you change this option. </div> |

Network setup

| Option | Description |
|----------------------|--|
| Protocol Mgr. | <ul style="list-style-type: none">• SNMPv1/v2: You have to enable this option to use SNMP V1/V2 protocol. Administrator's can use SNMP to monitor and manage machines on the network.• UPnP(SSDP): You have to enable this option to use UPnP(SSDP) protocol. <div data-bbox="358 523 1079 678"> Turn the power off and on after you change this option.</div> <ul style="list-style-type: none">• mDNS: You have to enable this option to use MDNS (Multicast Domain Name System) protocol.• SetIP: You have to enable this option to use SetIP protocol.• SLP: You can configure SLP (Service Location Protocol) settings. This protocol allows host applications to find services in a local area network without prior configuration. <div data-bbox="358 1082 1079 1236"> Turn the power off and on after you change this option.</div> |



4. Special Features

This chapter explains special copying, scanning, faxing, and printing features.

- **Altitude adjustment** 225
- **Entering various characters** 226
- **Setting up the fax address book** 227
- **Printing features** 230
- **Scan features** 241
- **Fax features** 249



- The procedures in this chapter are mainly based on Windows 7.
- It may be necessary to press **OK** to navigate to lower-level menus for some models.

Altitude adjustment

Print quality is affected by atmospheric pressure, which is determined by the height of the machine above sea level. The following information will guide you on how to set your machine for the best print quality.

Before you set the altitude value, determine the altitude where you are.

- **Normal:** 0 ~ 1,000 m (3,280 ft)
- **High 1 :** 1,000 m (3,280 ft) ~ 2,000 m (6,561 ft)
- **High 2:** 2,000 m (6,561 ft) ~ 3,000 m (9,842 ft)
- **High 3:** 3,000 m (9,842 ft) ~ 4,000 m (13,123 ft)
- **High 4:** 4,000 m (13,123 ft) ~ 5,000 m (16,404 ft)

You can set the altitude value from **Device Settings** in Samsung Easy Printer Manager program.



- If your machine is connected to the local, you can set the machine's setting from **Samsung Easy Printer Manager > Advanced Setting > Device Settings** (see "Using Samsung Easy Printer Manager" on page 268).
- If your machine is connected to the network, you can set the machine's setting from **SyncThru™ Web Service > Settings tab > Machine Settings** (see "Using SyncThru™ Web Service" on page 265).
- You can also set the altitude in **System Setup** option on the machine's display (see "Machine's basic settings" on page 38).

Entering various characters



C48xFN/C48xFW series only (see "Control panel overview" on page 24).

As you perform various tasks, you may need to enter names and numbers. For example, when you set up your machine, you enter your name or your company's name, and the fax number. When you store fax numbers or email addresses in memory, you may also enter the corresponding names.

Entering alphanumeric characters

Press the button until the correct letter appears on the display. For example, to enter the letter O, press 6, labeled with MNO. Each time you press 6, the display shows a different letter, M, N, O, m, n, o and finally 6. To find the letter that you want to enter, see "Keypad letters and numbers" on page 226.



- You can enter a space by pressing 1 twice.
- To delete the last digit or character, press the left/right or up/down arrow button.

Keypad letters and numbers



- Special character sets may differ from your machine depending on its options or the models.
- Some of the follow key values may not appear depending on the job you are doing.

| Key | Assigned numbers, letters, or characters |
|-----|---|
| 1 | @ / . ' 1 |
| 2 | A B C a b c 2 |
| 3 | D E F d e f 3 |
| 4 | G H I g h i 4 |
| 5 | J K L j k l 5 |
| 6 | M N O m n o 6 |
| 7 | P Q R S p q r s 7 |
| 8 | T U V t u v 8 |
| 9 | W X Y Z w x y z 9 |
| 0 | & + - , 0 |
| * | * % ^ _ ~ ! # \$ () [] (These symbols are available when you type for network authentication.) |
| # | # = ? " : { } < > ; (These symbols are available when you type for network authentication.) |



Setting up the fax address book



C48xFN/C48xFW series only (see "Control panel overview" on page 24).

You can set up speed number with the fax numbers you use frequently via SyncThru™ Web Service and then easily and quickly enter fax numbers by entering the location numbers assigned to them in address book.

Registering a speed dial number

- 1 Select  (fax) >  (**Address Book**) > **New&Edit** > **Speed Dial** on the control panel.
- 2 Enter a speed dial number and press **OK**.





If an entry is already stored in the number you choose, the display shows the message to allow you to change it. To start over with another speed dial number, press  (**Back**).

- 3 Enter the name you want and press **OK**.
- 4 Enter the fax number you want and press **OK**.
- 5 Press the  (**Stop/Clear**) button to return to ready mode.



Using speed dial numbers

When you are prompted to enter a destination number while sending a fax, enter the speed dial number at which you stored the number you want.





- For a one-digit (0-9) speed dial number, press and hold the corresponding digit button on the number keypad for more than 2 seconds.
- For a two- or three-digit speed dial number, press the first digit button(s) and then hold down the last digit button for more than 2 seconds.
- You can print the address book list by selecting  (fax) >  (**Address Book**) > **Print**.

Editing speed dial numbers

- 1 Select  (fax) >  (**Address Book**) > **New&Edit** > **Speed Dial** on the control panel.
- 2 Enter the speed dial number you want to edit and press **OK**.
- 3 Change the name and press **OK**.
- 4 Change the fax number and press **OK**.
- 5 Press  (**Stop/Clear**) to return to ready mode.

Setting up the fax address book

Registering a group dial number



- 1 Select  (fax) >  (**Address Book**) > **New&Edit** > **Group Dial** on the control panel.
- 2 Enter a group dial number and press **OK**.



If an entry is already stored in the number you choose, the display shows the message to allow you to change it. To start over with another speed dial number, press  (**Back**).

- 3 Search by entering the first few letters of the speed dial's name to put in the group.
- 4 Select the name and number you want and press **OK**.
- 5 Select **Yes** when **Add?** appears.
- 6 Repeat step 3 to include other speed dial numbers into the group.
- 7 When you have finished, select **No** when **Another No.?** appears and press **OK**.
- 8 Press  (**Stop/Clear**) to return to ready mode.



Editing group dial numbers

- 1 Select  (fax) >  (**Address Book**) > **New&Edit** > **Group Dial** on the control panel.
- 2 Enter the group dial number you want to edit and press **OK**.
- 3 Enter a new speed dial number to add and press **OK**, then **Add?** appears. Enter a speed dial number stored in the group and press **OK**, **Delete?** appears.
- 4 Press **OK** to add or delete the number.
- 5 Repeat step 3 to add or delete more numbers.
- 6 Select **No** at the **Another No.?** and press **OK**.
- 7 Press  (**Stop/Clear**) to return to ready mode.

Setting up the fax address book

Searching address book for an entry



There are two ways to search for a number in memory. You can either scan from A to Z sequentially, or you can search by entering the first letters of the name associated with the number.

- 1 Select ct  (fax) >  (**Address Book**) > **Search&Dial** > **Speed Dial** or **Group Dial** on the control panel.
- 2 Enter **All** or **ID** and press **OK**.
- 3 Press the name and number or the keypad button labeled with the letter you want to search.

For example, if you want to find the name "MOBILE," press the **6** button, which is labeled with "MNO."
- 4 Press  (**Stop/Clear**) to return to ready mode.

Printing address book

You can check your  (**Address Book**) settings by printing a list.

- 1 Select ct  (fax) >  (**Address Book**) > **Print** on the control panel.
- 2 Press **OK**.

The machine begins printing.

Printing features



- For basic printing features, refer to the Basic Guide (see "Basic printing" on page 54).
- This feature may not be available depending on model or optional goods (see "Features by model" on page 7).

Changing the default print settings

- 1 Click the Windows **Start** menu.
 - For Windows 8, from the **Charms**, select **Search > Settings**.
- 2 For Windows XP Service Pack 3/Server 2003, select **Printer and Faxes**.
 - For Windows Server 2008/Vista, select **Control Panel > Hardware and Sound > Printers**.
 - For Windows Server 2008 R2, select **Control Panel > Hardware > Devices and Printers**.
 - For Windows 7/8, select **Control Panel > Devices and Printers**.
- 3 Right-click on your machine.
- 4 For Windows XP Service Pack 3/Server 2003/Server 2008/Vista, select **Printing Preferences**.
For Windows 7/8 or Windows Server 2008 R2, from context menus, select **Printing preferences**.



If **Printing preferences** has a ►, you can select other printer drivers connected to the selected printer.

- 5 Change the settings on each tab.
- 6 Click **OK**.



If you want to change the settings for each print job, change it in **Printing Preferences**.

Setting your machine as a default machine

- 1 Click the Windows **Start** menu.
 - For Windows 8, from the **Charms**, select **Search > Settings**.
- 2 For Windows XP Service Pack 3/Server 2003, select **Printer and Faxes**.
 - For Windows Server 2008/Vista, select **Control Panel > Hardware and Sound > Printers**.
 - For Windows Server 2008 R2, select **Control Panel > Hardware > Devices and Printers**.
 - For Windows 7/8, select **Control Panel > Devices and Printers**.

Printing features

- 3 Select your machine.
- 4 Right-click your machine and select **Set as Default Printer**.

 For Windows 7 or Windows Server 2008 R2, if **Set as default printer** has a ►, you can select other printer drivers connected to the selected printer.

Using advanced print features

-  **XPS printer driver:** used to print XPS file format.
- See "Features by model" on page 7.
 - The XPS printer driver can be installed only on Windows Vista OS or higher.
 - For models that provide XPS driver from the Samsung website, <http://www.samsung.com> > find your product > Support or downloads.

Printing to a file (PRN)

You will sometimes need to save the print data as a file.

- 1 Check the **Print to file** box in the **Print** window.

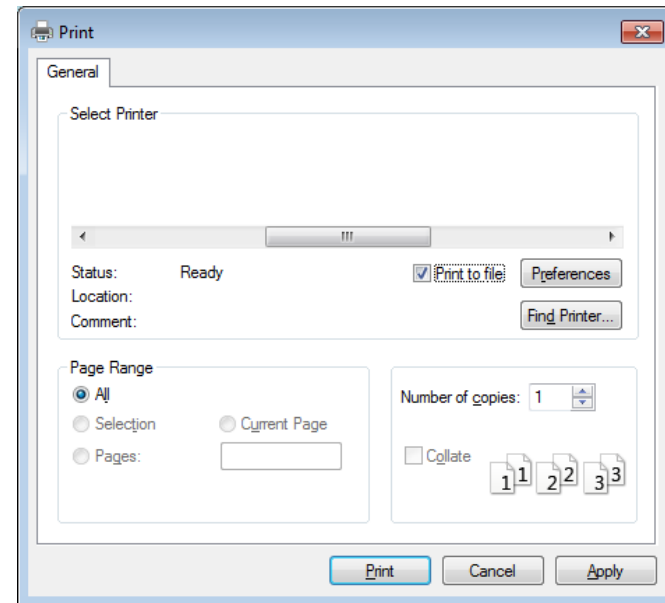

- 2 Click **Print**.
- 3 Type in the destination path and the file name, and then click **OK**.
For example, **c:\Temp\file name**.

 If you type in only the file name, the file is automatically saved in **My Documents**, **Documents and Settings**, or **Users**. The saved folder may differ, depending on your operating system or the application you are using.

Printing features

Understanding special printer features

You can use advanced printing features when using your machine.





To take advantage of the printer features provided by your printer driver, click **Properties** or **Preferences** in the application's **Print** window to change the print settings. The machine name that appears in the printer properties window may differ depending on the machine in use.

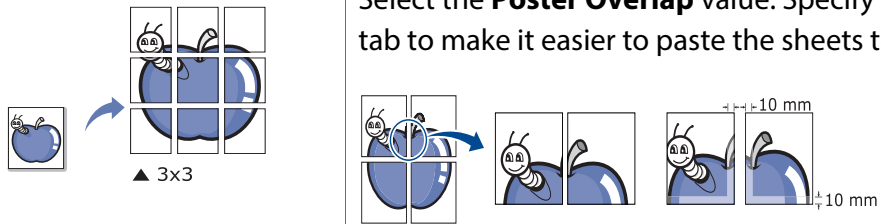

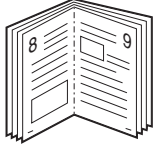

- Some menus may not appear on the display depending on options or models. If so, it is not applicable to your machine.
- Select the **Help** menu or click the  button from the window or press **F1** on your keyboard and click on any option you want to know about (see "Using help" on page 57).

| Item | Description |
|--|---|
| <p data-bbox="51 815 387 847">Multiple Pages per Side</p>  | <p data-bbox="409 815 2186 887">Selects the number of pages to print on a single sheet of paper. To print more than one page per sheet, the pages will be reduced in size and arranged in the order you specify. You can print up to 16 pages on one sheet.</p> |
| <p data-bbox="51 1134 264 1166">Poster Printing</p>  | <p data-bbox="409 1094 2163 1166">Prints a single-page document onto 4 (Poster 2x2), 9 (Poster 3x3), or 16 (Poster 4x4) sheets of paper, for the purpose of pasting the sheets together to form one poster-size document.</p> <p data-bbox="409 1190 2175 1262">Select the Poster Overlap value. Specify Poster Overlap in millimeters or inches by selecting the radio button on the upper right of Basic tab to make it easier to paste the sheets together.</p> |

Printing features

| Item | Description |
|--|--|
| <p data-bbox="53 373 293 408">Booklet Printing^a</p>  | <p data-bbox="412 272 2123 347">Prints your document on both sides of a sheet of paper and arranges the pages so that the paper can be folded in half after printing to produce a booklet.</p> <div data-bbox="412 400 2190 687"><ul data-bbox="510 427 2190 643" style="list-style-type: none"><li data-bbox="510 427 2190 467">• This option is available only when you use the PCL/SPL printer driver. This option is not available when you use XPS driver.<li data-bbox="510 480 2190 552">• The Booklet Printing option is not available for all paper sizes. Select the available paper Size option under the Paper tab to see what paper sizes are available.<li data-bbox="510 564 2190 643">• If you select an unavailable paper size, this option can be automatically canceled. Select only available paper (paper without  or  mark).</div> |

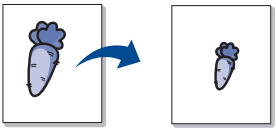

Printing features

| Item | Description |
|--|---|
| <p>Double-sided Printing (Manual)</p> | <p>Print on both sides of a sheet of paper (duplex). Before printing, decide how you want your document oriented.</p> <div data-bbox="414 355 2190 603" style="background-color: #f0f0f0; padding: 10px;"><p> • This option is available only when you use the PCL/SPL printer driver. This option is not available when you use XPS driver.</p><p>• If your machine does not have a duplex unit, you should complete the printing job manually. The machine prints every other page of the document first. After that, a message appears on your computer.</p><p>• Skip Blank Pages feature does not work when you select the duplex option.</p></div> <ul style="list-style-type: none">• None: Disables this feature.• Long Edge: This option is the conventional layout used in bookbinding. <div data-bbox="450 746 667 858">The diagram shows two sheets of paper. The left sheet is oriented vertically with a person icon on the left side. The right sheet is oriented horizontally with a person icon on the top side. This represents long edge printing.</div> <ul style="list-style-type: none">• Short Edge: This option is the conventional layout used in calendars. <div data-bbox="450 943 667 1075">The diagram shows two sheets of paper. The left sheet is oriented vertically with a person icon on the top side. The right sheet is oriented horizontally with a person icon on the left side. This represents short edge printing.</div> |
| <p>Paper Options</p> <div data-bbox="56 1177 331 1305">The diagram shows two rectangular boxes. The left box contains a larger carrot icon, and the right box contains a smaller carrot icon. A blue arrow points from the larger box to the smaller box, indicating a reduction in size.</div> | <p>Changes the size of a document to appear larger or smaller on the printed page by entering in a percentage by which to enlarge or decrease the document.</p> |

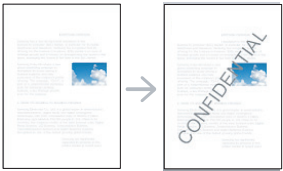
Printing features

| Item | Description |
|--|--|
| <p>Watermark</p>  | <p>The watermark option allows you to print text over an existing document. For example, you use it when you want to have large gray letters reading "DRAFT" or "CONFIDENTIAL" printed diagonally across the first page or all pages of a document.</p> <ul style="list-style-type: none"> • Header: You can add the selected text to the top left, top center, or top right. • Footer: You can add the selected text to the bottom left, bottom center, or bottom right. |
| <p>Watermark (Creating a watermark)</p> | <p>aTo change the print settings from your software application, access Printing Preferences (see "Opening printing preferences" on page 56). bFrom the Advanced tab, select Edit... from the Watermark drop-down list. cEnter a text message in the Watermark Message box. You can enter up to 256 characters. When the First Page Only box is checked, the watermark prints on the first page only. dSelect watermark options. You can select the font name, style, size, and shade from the Font Attributes section, as well as set the angle of the watermark from the Watermark Alignment and Angle section. eClick Add to add a new watermark to the Current Watermarks list. fWhen you finish editing, click OK or Print until you exit the Print window.</p> |
| <p>Watermark (Editing a watermark)</p> | <p>aTo change the print settings from your software application, access Printing Preferences (see "Opening printing preferences" on page 56). bClick the Advanced tab, select Edit... from the Watermark drop-down list. cSelect the watermark you want to edit from the Current Watermarks list and change the watermark message and options. dClick Update to save the changes. eClick OK or Print until you exit the Print window.</p> |
| <p>Watermark (Deleting a watermark)</p> | <p>aTo change the print settings from your software application, access Printing Preferences. bClick the Advanced tab, select Edit... from the Watermark drop-down list. cSelect the watermark you want to delete from the Current Watermarks list and click Delete. dClick OK or Print until you exit the Print window.</p> |

Printing features

| Item | Description |
|---|---|
| <p data-bbox="53 411 174 443">Overlay^a</p>  | <p data-bbox="412 272 1635 304">This option is available only when you use the PCL/SPL printer driver (see "Software" on page 8).</p> <p data-bbox="412 328 2184 485">An overlay is text and/or images stored in the computer hard disk drive (HDD) as a special file format that can be printed on any document. Overlays are often used to take the place of letterhead paper. Rather than using preprinted letterhead, you can create an overlay containing exactly the same information that is currently on your letterhead. To print a letter with your company's letterhead, you do not need to load preprinted letterhead paper in the machine: just print the letterhead overlay on your document.</p> <p data-bbox="412 509 1563 541">To use a page overlay, you must create a new page overlay containing your logo or image.</p> <div data-bbox="412 592 2190 788" style="background-color: #f0f0f0; padding: 10px;"><ul data-bbox="510 624 2094 746" style="list-style-type: none"><li data-bbox="510 624 2094 692">• The overlay document size must be the same as the document you print with the overlay. Do not create an overlay with a watermark.<li data-bbox="510 711 2094 746">• The resolution of the overlay document must be the same as that of the document you will print with the overlay.</div> |
| <p data-bbox="53 970 344 1098">Overlay^a (Creating a new page overlay)</p> | <p data-bbox="412 826 2184 895">aCreate or open a document containing text or an image for use in a new page overlay. Position the items exactly as you wish them to appear when printed as an overlay.</p> <p data-bbox="412 911 1272 943">bTo save the document as an overlay, access Printing Preferences.</p> <p data-bbox="412 959 1400 991">cClick the Advanced tab, and select Create from the Overlay drop-down list.</p> <p data-bbox="412 1007 2161 1075">dIn the Save As window, type a name up to eight characters in the File name box. Select the destination path, if necessary (The default is C:\Formover).</p> <p data-bbox="412 1091 568 1123">eClick Save.</p> <p data-bbox="412 1139 1167 1208">fClick OK or Print until you exit the Print window. When a confirming message window appears, click Yes.</p> <p data-bbox="412 1224 1391 1256">gThe file is not printed. Instead, it is stored on your computer hard disk drive.</p> |

Printing features

| Item | Description |
|--|---|
| Overlay^a (Using a page overlay) | <p>aCreate or open the document you want to print.</p> <p>bTo change the print settings from your software application, access Printing Preferences.</p> <p>cClick the Advanced tab.</p> <p>dSelect the Print Overlay from the Overlay drop-down list.</p> <p>eIf the overlay file you want does not appear in the Overlay File 1 or Overlay File 2 drop-down list, select Load from the Overlay List. Select the overlay file you want to use.</p> <p>If you have stored the overlay file you want to use in an external source, you can also load the file when you access the Load window. After you select the file, click Open. The file appears in the Overlay List box and is available for printing. Select the overlay from the Overlay List box.</p> <p>fIf necessary, check Confirm Page Overlay When Printing box. If this box is checked, a message window appears each time you submit a document for printing, asking you to confirm your wish to print an overlay on your document.</p> <p>If this box is not checked and an overlay has been selected, the overlay automatically prints with your document.</p> <p>gClick OK or Print until you exit the Print window.</p> <p>The selected overlay prints on your document.</p> |
| Overlay^a (Deleting a page overlay) | <p>aIn the Printing Preferences window, click the Advanced tab.</p> <p>bSelect Edit in the Text drop down list.</p> <p>cSelect the overlay you want to delete from the Overlay List box.</p> <p>dClick Delete.</p> <p>eWhen a confirming message window appears, click Yes.</p> <p>fClick OK or Print until you exit the Print window. You can delete page overlays that you no longer use.</p> |

a. This option is not available when you use XPS driver.

Printing features

Mac printing



Some features may not be available depending on models or options. It means that the features are not supported.

Printing a document

When you print with a Mac, you need to check the printer driver settings in each application you use. Follow the steps below to print from a Mac:

- 1 Open the document to print.
- 2 Open the **File** menu and click **Page Setup** (**Document Setup** in some applications).
- 3 Choose your paper size, orientation, scaling, other options, and make sure that your machine is selected. Click **OK**.
- 4 Open the **File** menu and click **Print**.
- 5 Choose the number of copies and indicate which pages to print.
- 6 Click **Print**.

Changing printer settings

You can use advanced printing features when using your machine.

Open an application and select **Print** from the **File** menu. The machine name, which appears in the printer properties window, may differ depending on the machine in use. Except for the name, the composition of the printer properties window is similar to the following.

Printing multiple pages on one sheet

You can print more than one page on a single sheet of paper. This feature provides a cost-effective way to print draft copies.

- 1 Open an application, and select **Print** from the **File** menu.
- 2 Select **Layout** from the drop-down list under **Orientation**. In the **Pages per Sheet** drop-down list, select the number of pages you want to print on one sheet of paper.
- 3 Select the other options to use.
- 4 Click **Print**.
The machine prints the selected number of pages to print on one sheet of paper.

Printing features

Printing on both sides of the paper



Some features may not be available depending on models or options. It means that the features are not supported (see "Variety feature" on page 10).

Before printing in the duplex mode, decide on which edge you will be binding your finished document. The binding options are, as follows:

- **Long-Edge Binding:** This option is the conventional layout used in book binding.
- **Short-Edge Binding:** This option is the type often used with calendars.

- 1 From your Mac application, select **Print** from the **File** menu.
- 2 Select **Layout** from the drop-down list under **Orientation**.
- 3 Select a binding orientation from the **Two-Sided** option.
- 4 Select the other options to use.
- 5 Click **Print** and the machine prints on both sides of the paper.



If you print more than 2 copies, the first copy and the second copy might print on the same sheet of paper. Avoid printing on both sides of paper when you are printing more than 1 copy.

Using help

Click the question mark on the bottom-left corner of the window and click on the topic you want to know about. A pop-up window appears with information about that option's feature, which is provided from the driver.

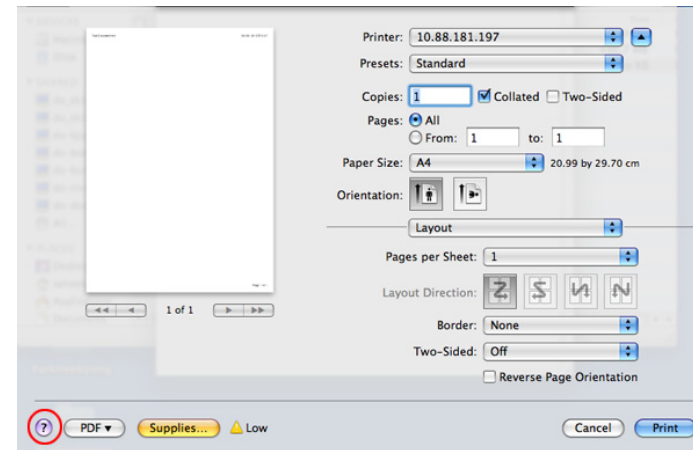

Printing features

Linux printing



Some features may not be available depending on models or options. It means that the features are not supported.

Printing from applications

There are a lot of Linux applications that allow you to print using Common UNIX Printing System (CUPS). You can print on your machine from any such application.

- 1 Open the document to print.
- 2 Open the **File** menu and click **Page Setup (Print Setup** for some applications).
- 3 Choose your paper size, orientation, and make sure that your machine is selected. Click **Apply**.
- 4 Open the **File** menu and click **Print**.
- 5 Select your machine to print.
- 6 Choose the number of copies and indicate which pages to print.
- 7 Change other printing options in each tab, if necessary.
- 8 Click **Print**.



Automatic/manual duplex printing may not be available depending on models. You can alternatively use the lpr printing system or other applications for odd-even printing (see "Features by model" on page 7).

Printing files

You can print text, image, pdf files on your machine using the standard CUPS directly from the command line interface. The CUPS lp or lpr utility allows you to do that. You can print these files by using below command format.

```
"lp -d <printer name> -o <option> <file name>"
```

Please refer to lp or lpr man page on your system for more details.

Configuring Printer Properties

You can change the default printing options or connection type with Printing utility supplied by o/s.

- 1 Launch Printing utility (Go to **System > Administration > Printing** menu or execute "**system-config-printer**" command in Terminal program).
- 2 Select your printer and double-click it.
- 3 Change default printing options or connection type.
- 4 Click **Apply** button.

Scan features



- For basic scanning features, refer to the Basic Guide (see "Basic scanning" on page 64).
- This feature may not be available depending on model or optional goods (see "Features by model" on page 7).
- The maximum resolution that can be achieved depends upon various factors, including computer speed, available disk space, memory, the size of the image being scanned, and bit depth settings. Thus, depending on your system and what you are scanning, you may not be able to scan at certain resolutions, especially using enhanced dpi.

Basic scanning method



- This feature may not be available depending on model or optional goods (see "Variety feature" on page 10).

You can scan the originals with your machine via a USB cable or the network. The following methodologies can be used for scanning your documents:

- **Scan to PC:** Scan the originals from the control panel. Then, the scanned data will be stored in the connected computers **My Documents** folder (see "Basic Scanning" on page 64).
- **Scan to Email:** You can send the scanned image as an email attachment (see "Scanning to email" on page 243).

- **Scan to WSD:** Scans the originals and saves the scanned data on a connected computer if the computer supports the WSD (Web Service for Device) feature (see "Scanning to WSD" on page 244).
- **Samsung Cloud:** You can send the scanned image as an Samsung cloud (see "Scanning and sending to Samsung Cloud Print" on page 199).
- **TWAIN:** TWAIN is the one of the preset imaging applications. Scanning an image launches the selected application, enabling you to control the scanning process. This feature can be used via the local connection or the network connection (see "Scanning from image editing program" on page 246).
- **Samsung Easy Document Creator:** You can use this program to scan images or documents (See "Using Samsung Easy Document Creator" on page 270).
- **WIA:** WIA stands for Windows Images Acquisition. To use this feature, your computer must be connected directly with the machine via a USB cable (see "Scanning using the WIA driver" on page 247).
- **Scan to USB:** You can scan a document and save the scanned image onto a USB memory device (see "Scanning to a USB memory device" on page 71).

Scan features

Setting the scan settings in the computer



This feature may not be available depending on model or optional goods (see "Features by model" on page 7).

- 1 Open **Samsung Easy Printer Manager** (see "Using Samsung Easy Printer Manager" on page 268).
- 2 Select the appropriate machine from the **Printer List**.
- 3 Select **Scan to PC Settings** menu.
- 4 Select the option you want.
 - Scan Activation:** Determines whether or not scanning is enabled on the device.
 - Basic** tab: Contains settings related to general scan and device settings.
 - Image** tab: Contains settings related to image altering.
- 5 Press **Save** > **OK**.

Scanning from network connected machine



This feature is not available for the machine that does not support the network interface (see "Rear view" on page 23).

Make sure the printer driver is installed on your computer using the software CD, since the printer driver includes the scan program (see "Installing the driver locally" on page 29).

- 1 Place a single document face down on the document glass, or load the documents face up into the document feeder (see "Loading originals" on page 50).
- 2 Select  (**Scan**) > **Scan to PC** > **Network PC** on the control panel.



If you see **Not Available** message, check the port connection.

- 3 Select your registered computer **ID**, and enter the **Password** if necessary.

Scan features



- **ID** is the same ID as the registered scan ID for **Samsung Easy Printer Manager > Advanced Settings > Scan to PC Settings**.
- **Password** is the 4 digit number registered password for **Samsung Easy Printer Manager > Advanced Settings > Scan to PC Settings**.

4 Select the option you want and press **OK**.

5 Scanning begins.



Scanned image is saved in computer's **C:\Users\users name\My Documents**. The saved folder may differ, depending on your operating system or the application you are using.

Scanning to email



This feature may not be available depending on model or optional goods (see "Features by model" on page 7).

Setting up an email account

- 1** Access the SyncThru™ Web Service (see "Using SyncThru™ Web Service" on page 265).
- 2** Select **Settings > Network Settings** and **Outgoing Mail Server(SMTP)**.
- 3** Enter the IP address in dotted decimal notation or as a host name.
- 4** Enter the server port number, from 1 to 65535.
- 5** Check the box next to **SMTP Requires Authentication** to require authentication.
- 6** Enter the SMTP server login name and password.
- 7** Press **Apply**.



- If the authentication method of SMTP server is POP3 before SMTP, put a check mark of **SMTP Requires POP Before SMTP Authentication**.
- Enter the IP address and port number.

Scan features

Scanning and sending an email

- 1 Place a single document face down on the document glass, or load the documents face up into the document feeder (see "Loading originals" on page 50).
- 2 Select  (scan) > **Scan to Email** on the control panel.
- 3 Enter the sender's and recipient's email address.

 You can send an email to yourself by activating the **Auto Send To Self** option in the **Settings > Scan > Scan To E-mail** on SyncThru™ Web Service.

- 4 Enter an email subject and press **OK**.
- 5 Select the file format to scan, and press **OK**.
- 6 The machine begins scanning and then sends the email.

Scanning to WSD

Scans the originals and saves the scanned data on a connected computer if the computer supports the WSD (Web Service for Device) feature. To use the WSD feature, you need to install the WSD printer driver on your computer. For Windows 7, you can install the WSD driver by **Control Panel > Devices and Printers > Add a printer**. Click **Add a network printer** from the wizard.



- The machine that does not support the network interface, it will not be able to use this feature (see "Features by model" on page 7).
- The WSD feature works only with Windows Vista® or later version that are the WSD-compliant computer.
- The following installation steps are based on Windows 7 computer.

Installing a WSD Printer Driver

- 1 Select **Start > Control Panel > Devices and Printers > Add a printer**.
- 2 Click **Add a network, wireless or Bluetooth printer** from the wizard.
- 3 In the printers list, select the one you want to use, and then click **Next**.

Scan features



- The IP address for WSD printer is http://IP address/ws/ (example: http://111.111.111.111/ws/).
- If no WSD printer is displayed in the list, click **The printer that I want isn't listed** > **Add a printer using a TCP/IP address or hostname** and select **Web Services Device** from **Device type**. Then enter the printer's IP address.

- 4 Follow the instructions in the installation window.

Scanning using the WSD feature

- 1 Make sure that the machine is connected to your computer and powered on.
- 2 Place a single document face down on the document glass, or load the documents face up into the document feeder (see "Loading originals" on page 50).
- 3 Select  (Scan) > **Scan to WSD** on the control panel.



If you see **Not Available** message, check the port connection. Or check the printer driver for WSD is correctly installed.

- 4 Select your computer name from **WSD PC List**.
- 5 Select the option you want and press **OK**.
- 6 Scanning begins.

Scanning with Samsung Easy Document Creator

Samsung Easy Document Creator is an application to help users scan, compile, and save documents in multiple formats, including .epub format.



- Available for Windows OS and Mac OS users only.
- Windows XP Service Pack 3 or higher and Internet Explorer 6.0 or higher is the minimum requirement for Samsung Easy Document Creator.
- Samsung Easy Document Creator is installed automatically when you install the machine software (see "Using Samsung Easy Document Creator" on page 270).

- 1 Place a single document face down on the document glass, or load the documents face up into the document feeder (see "Loading originals" on page 50).
- 2 From the **Start** menu select **Programs** or **All Programs** > **Samsung Printers**.
For Mac, open the **Applications** folder > **Samsung** folder > SamsungEasy Document Creator.
- 3 Click Samsung Easy Document Creator.
- 4 Click **Scan** from the home screen.

Scan features

- 5 Select the type of scanning or a favorites and then make adjustments to the image(**Options**).
- 6 Click **Scan** to scan a final image or **Prescan** to get another preview image.
- 7 Press **Send**.
- 8 Press the option you want.
- 9 Press **OK**.



Click the **Help** (?) button from the window, and then click on any option you want to know about.

Scanning from image editing program

You can scan and import documents in the image editing software such as Adobe Photoshop, if the software is TWAIN-compliant. Follow the steps below to scan with TWAIN-compliant software:

- 1 Make sure that the machine is connected to your computer and powered on.
- 2 Place a single document face down on the document glass, or load the documents face up into the document feeder (see "Loading originals" on page 50).
- 3 Open an application, such as Adobe Photoshop.
- 4 Click **File > Import**, and select the scanner device.
- 5 Set the scan options.
- 6 Scan and save your scanned image.

Scan features

Scanning using the WIA driver

Your machine supports the Windows Image Acquisition (WIA) driver for scanning images. WIA is one of the standard components provided by Microsoft Windows 7 and works with digital cameras and scanners. Unlike the TWAIN driver, the WIA driver allows you to scan and easily adjust images without using additional software:



The WIA driver works only on Windows OS (not supported Windows 2000) with a USB port.

- 1 Make sure that the machine is connected to your computer and powered on.
- 2 Place a single document face down on the document glass, or load the documents face up into the document feeder (see "Loading originals" on page 50).
- 3 Click **Start > Control Panel > Hardware and Sound > Devices and Printers**.
- 4 Right-click on device driver icon in **Printers and Faxes > Start Scan**.
- 5 **New Scan** application appears.

- 6 Choose your scanning preferences and click **Preview** to see how your preferences affect the picture.
- 7 Scan and save your scanned image.

MAC scanning

You can scan documents using **Image Capture** program. MAC OS X offers **Image Capture** program.

Scanning with network

- 1 Make sure that your machine is connected to a network.
- 2 Place the originals face up in the ADF or place a single original face down on the scanner glass and close the ADF (see "Loading originals" on page 50).
- 3 Open the **Applications** folder and run **Image Capture**.
- 4 Select your device below **SHARED**.
- 5 Set the scan options on this program.
- 6 Scan and save your scanned image.

Scan features



- If scanning does not operate in Image Capture, update Mac OS to the latest version.
- For more information, refer to the **Image Capture**'s help.
- You can also scan using TWAIN-compliant software, such as Adobe Photoshop.
- You can scan using **Samsung Easy Document Creator** software. Open the **Applications** folder > **Samsung** folder > **Samsung Easy Document Creator**.

Linux scanning

- 1 Make sure that the machine is connected to your computer and powered on.
- 2 Launch a scan application such as xsane or simple-scan (If it's not installed, please install it manually to use scan features. For example, you may use "yum install xsane" for rpm package systems and "apt-get install xsane" for deb package systems to install xsane).
- 3 Select your device from the list and set the scan options to apply.
- 4 Click the **Scan** button.



Fax features





- For basic faxing features, refer to the Basic Guide (see "Basic faxing" on page 65).
- C48xFN/C48xFW series only (see "Control panel overview" on page 24).

Automatic redialing

When the number you have dialed is busy or there is no answer when you send a fax, the machine automatically redials the number. The redial time depends on the country's factory default setting.

When the display shows **Retry Redial?**, press  (**Start**) button to redial the number without waiting. To cancel the automatic redialing, press  (**Stop/Clear**).

To change the time interval between redials and the number of redial attempts.

- 1 Press  (fax) >  (**Menu**) > **Fax Setup** > **Sending** on the control panel.
- 2 Select **Redial Times** or **Redial Term** you want.
- 3 Select the option you want.

Redialing the fax number

- 1 Press  (**Redial/Pause**) button on the control panel.
- 2 Select the fax number you want.
Ten recently sent fax numbers with ten received Caller IDs are shown.
- 3 When an original is loaded in the document feeder, the machine automatically begins to send.
If an original is placed on the scanner glass, select **Yes** to add another page. Load another original and press **OK**. When you have finished, select **No** when **Another Page?** appears.



Confirming a transmission

When the last page of your original has been sent successfully, the machine beeps and returns to ready mode.

When something goes wrong while sending your fax, an error message appears on the display. If you receive an error message, press  (**Stop/Clear**) to clear the message and try to send the fax again.

Fax features



You can set your machine to print a confirmation report automatically each time sending a fax is completed. Press  (fax) >  (Menu) > **Fax Setup** > **Sending** > **Fax Confirm**, on the control panel.

Sending a fax from your computer



- This feature may not be available depending on model or optional goods (see "Features by model" on page 7).

You can send a fax from your computer without going to the machine.

Make sure that your machine and the computer are connected to the same network.

Sending a fax (Windows)

To send a fax from your computer, the **Samsung Network PC Fax** program must be installed. This program is installed when you install the printer driver.



For more information about **Samsung Network PC Fax**, click **Help**.

- 1 Open the document to be sent.
- 2 Select **Print** from the **File** menu.
The **Print** window will be displayed. It may look slightly different depending on your application.
- 3 Select **Samsung Network PC Fax** from the **Print** window
- 4 Click **Print** or **OK**.
- 5 Enter the recipient's fax number and set the options if necessary.
- 6 Click **Send**.

Checking the sent fax list (Windows)

You can check the sent fax list from your computer.

From the **Start** menu, click **Programs** or **All Programs** > **Samsung Printers** > **Fax Transmission History**. Then, the window appears with the list of faxes sent.





For more information about **Fax Transmission History**, click the **Help** (?) button.

Fax features

Delaying a fax transmission

You can set your machine to send a fax at a later time when you will not be present. You cannot send a color fax using this feature.

- 1 Place a single document face down on the document glass, or load the documents face up into the document feeder.
- 2 Press  (fax) on the control panel.
- 3 Adjust the resolution and the darkness to suit your fax needs.
- 4 Press  (**Menu**) > **Fax Feature** > **Delay Send** on the control panel.
- 5 Enter the number of the receiving fax machine and press **OK**.
- 6 The display asks you to enter another fax number to send the document.
- 7 To enter more fax numbers, press **OK** when **Yes** highlights and repeat steps 5.



You can add up to 10 destinations.

- 8 Enter the job name and the time.



If you set a time earlier than the current time, the fax will be sent at that time on the following day.



- 9 The original is scanned into memory before transmission.
The machine returns to ready mode. The display reminds you that you are in ready mode and that a delayed fax is set.



You can check the list of delayed fax jobs.

Press  (**Menu**) > **System Setup** > **Report** > **Scheduled Jobs** on the control panel.



Canceling a reserved fax job

- 1 Press  (fax) >  (**Menu**) > **Fax Feature** > **Cancel Job** on the control panel.
- 2 Select the fax job you want and press **OK**.
- 3 Press **OK** when **Yes** highlights.
The selected fax is deleted from memory.
- 4 Press  (**Stop/Clear**) to return to ready mode.

Fax features

Forwarding a sent fax to another destination

You can set the machine to forward the received or sent fax to other destination by a fax, an email or a server. If you are out of office but have to receive the fax, this feature may be useful.

- 1 Place a single document face down on the document glass, or load the documents face up into the document feeder.
- 2 Press  (fax) >  (**Menu**) > **Fax Feature** > **Send Forward** > **Forward to Fax , Fwd. to Email > On** on the control panel.

 **Forward** options may not be available depending on model or optional goods (see "Variety feature" on page 10).

- 3 Enter the destination fax number, email address, or server address and press **OK**.
- 4 Press  (**Stop/Clear**) to return to ready mode.
Subsequent sent faxes will be forwarded to the specified fax machine.

Forwarding a received fax

You can set the machine to forward the received or sent fax to other destination by a fax, an email or a server. If you are out of office but have to receive the fax, this feature may be useful.

- 1 Press  (fax) >  (**Menu**) > **Fax Feature** > **Rcv. Forward** > **Forward to Fax, Forward to PC, Fwd. to Email > Forward** on the control panel.



- **Forward** options may not be available depending on model or optional goods (see "Variety feature" on page 10).
- To set the machine to print out a fax when fax forwarding has been completed, select **Forward&Print**.

- 2 Enter the destination fax number, email address, or server address and press **OK**.
- 3 Enter the starting time and ending time, then press **OK**.
- 4 Press  (**Stop/Clear**) to return to ready mode.
Subsequent sent faxes will be forwarded to the specified fax machine.

Fax features

Receiving a fax in the computer



- This feature may not be available depending on model or optional goods (see "Features by model" on page 7).
- To use this feature, set the option on the control panel:





Press  (fax) >  (Menu) > **Fax Feature** > **Rcv. Forward** > **Forward to PC** > **Forward** the control panel.

- 1 Open the Samsung Easy Printer Manager.
- 2 Select the appropriate machine from the **Printer List**.
- 3 Select **Fax to PC Settings** menu.
- 4 Use **Enable Fax Receiving from Device** to change the fax settings.
 - Image Type:** Convert the received faxes to PDF or TIFF.
 - Save Location:** Select location to save the converted faxes.
 - Prefix:** Select prefix.
 - Print received fax:** Set to print information for the received fax after receiving the fax.
 - Notify me when complete:** Set to show the pop-up window to notify receiving a fax.

- Open with default application:** After receiving the fax, open it with default application.
- None:** After receiving a fax, the machine does not notify the user or opens the application.

- 5 Press **Save** > **OK**.

Changing the receive modes

- 1 Press  (fax) >  (Menu) > **Fax Setup** > **Receiving** > **Receive Mode** on the control panel.
- 2 Select the option you want.
 - Fax:** Answers an incoming fax call and immediately goes into the fax reception mode.
 - Tel:** Receives a fax by pressing  (**On Hook Dial**) and then  (**Start**) button.
 - Ans/Fax:** Is for when an answering machine is attached to your machine. Your machine answers an incoming call, and the caller can leave a message on the answering machine. If the fax machine senses a fax tone on the line, the machine automatically switches to Fax mode to receive the fax.

Fax features



To use the **Ans/Fax** mode, attach an answering machine to the EXT socket on the back of your machine.

•**DRPD:** You can receive a call using the Distinctive Ring Pattern Detection (DRPD) feature. Distinctive Ring is a telephone company service which enables an user to use a single telephone line to answer several different telephone numbers. For further details, see "Receiving faxes using DRPD mode" on page 255.



This setting may not be available depending on your country.



3

Press **OK**.

4

Press  (**Stop/Clear**) to return to ready mode.

Receiving manually in Tel mode

You can receive a fax call by pressing  (**On Hook Dial**) button and then pressing  (**Start**) when you hear a fax tone.

Receiving in Answering Machine/Fax mode

To use this mode, you must attach an answering machine to the EXT socket on the back of your machine. If the caller leaves a message, the answering machine stores the message. If your machine detects a fax tone on the line, it automatically starts to receive the fax.



- If you have set your machine to this mode and your answering machine is switched off, or no answering machine is connected to EXT socket, your machine automatically goes into Fax mode after a predefined number of rings.
- If the answering machine has a user-selectable ring counter, set the machine to answer incoming calls within 1 ring.
- If the machine is in Tel mode, disconnect or switch off the answering machine with the fax machine. Otherwise, the outgoing message from the answering machine will interrupt your phone conversation.

Receiving faxes with an extension telephone

When you are using an extension telephone connected to the EXT socket, you can receive a fax from someone you are talking to on the extension telephone, without going to the fax machine.

When you receive a call on the extension phone and hear fax tones, press the keys ***9*** on the extension phone. The machine receives the fax.

Fax features

9 is the remote receive code preset at the factory. The first and the last asterisks are fixed, but you can change the middle number to whatever you want.



While you are talking over the telephone connected to the EXT socket, copy and scan features are not available.

Receiving faxes using DRPD mode

This setting may not be available depending on your country. Distinctive Ring is a telephone company service which enables an user to use a single telephone line to answer several different telephone numbers. This feature is often used by answering services who answer telephones for many different clients and need to know which number someone is calling in on to properly answer the phone.



This setting may not be available depending on your country.

- 1 Select (fax) > (**Menu**) > **Fax Setup** > **Receiving** > **DRPD Mode** > **Waiting Ring** on the control panel.
- 2 Call your fax number from another telephone.

- 3 When your machine begins to ring, do not answer the call. The machine requires several rings to learn the pattern.

When the machine completes learning, the display shows **Completed DRPD Setup**. If the DRPD setup fails, **Error DRPD Ring** appears.

- 4 Press **OK** when DRPD appears and start over from step 2.



- DRPD must be set up again if you re-assign your fax number, or connect the machine to another telephone line.
- After DRPD has been set up, call your fax number again to verify that the machine answers with a fax tone. Then have a call placed to a different number assigned to that same line to be sure the call is forwarded to the extension telephone or answering machine plugged into the EXT socket.

Receiving in secure receiving mode





This feature may not be available depending on model or optional goods (see "Features by model" on page 7).



You may need to prevent your received faxes from being accessed by unauthorized people. Turn on secure receiving mode, then all incoming faxes go into memory. You can print the incoming faxes by entering the password.

Fax features



To use the secure receiving mode, activate the menu from  (fax) >  (Menu) > **Fax Feature** > **Secure Receive** on the control panel.

Printing received faxes

- 1 Select  (fax) >  (Menu) > **Fax Feature** > **Secure Receive** > **Print** on the control panel.
- 2 Enter a four-digit password and press **OK**.
- 3 The machine prints all of the faxes stored in memory.

Receiving faxes in memory

Since your machine is a multi-tasking device, it can receive faxes while you are making copies or printing. If you receive a fax while you are copying or printing, your machine stores incoming faxes in its memory. Then, as soon as you finish copying or printing, the machine automatically prints the fax.



If fax is received and being printed, other copy and print jobs cannot be processed at the same time.



5. Useful Management Tools

This chapter introduces management tools provided to help you make full use of your machine.

- **Accessing management tools** 258
- **Easy Capture Manager** 259
- **Samsung Easy Color Manager** 260
- **Easy Eco Driver** 261
- **Using Samsung Printer Center** 262
- **Using SyncThru™ Web Service** 265
- **Using Samsung Easy Printer Manager** 268
- **Using Samsung Easy Document Creator** 270
- **Using Samsung Printer Status** 271
- **Using Samsung Printer Experience** 273



Accessing management tools

Samsung provides a variety of management tools for Samsung printers.

- 1 Make sure that the machine is connected to your computer and powered on.
- 2 From the **Start** menu, select **Programs** or **All Programs**.
•For Windows 8, from the **Charms**, select **Search** > **Apps**.
- 3 Find **Samsung Printers**.
- 4 Under **Samsung Printers**, you can see installed management tools.
- 5 Click the management tool you want to use.



- After installing the driver, for some management tools, you can access them directly from the **Start** menu > **Programs** or **All Programs**.
- For Windows 8, after installing the driver, for some management tools, you can access them directly from the **Start** screen by clicking on the corresponding tile.

Easy Capture Manager



- This feature may not be available depending on model or optional goods (see "Software" on page 8).
- Available for Windows OS users only (see "Software" on page 8).

Capture your screen and launch Easy Capture Manager by simply pressing the Print Screen key on the keyboard. Now you can easily print your captured screen as captured or edited.

Samsung Easy Color Manager

Samsung Easy Color Manager helps users do fine adjustments with 6 color tones and other properties, such as brightness, contrast, and saturation. Color tone changes can be saved as a profile and can be used from the driver or from inside of the machine.



- This feature may not be available depending on model or optional goods (see "Software" on page 8).
- Available for Windows and Mac OS users only (see "Software" on page 8).

Helps Samsung color laser printer users to adjust color as they like.

Download the software from the Samsung website then unpack and install it: (<http://www.samsung.com> > find your product > Support or Downloads).

Easy Eco Driver



- Available for Windows OS users only.
- To use the Easy Eco Driver features, the Eco Driver Pack must be installed.

With the Easy Eco Driver, you can apply Eco features to save paper and toner before printing.

Easy Eco Driver also allows you to do simple editing such as removing images and texts, and more. You can save frequently used settings as a favorite.

How to use:

- 1 Open a document to print.
- 2 Open **printing preference window** (see "Opening printing preferences" on page 56).
- 3 From the **Favorites** tab, select **Eco Printing Preview**.
- 4 Click **OK > Print** in the window.
A preview window appears.
- 5 Select the options you want to apply to the document.
You can see the preview of the applied features.
- 6 Click **Print**.



- If you want to run Easy Eco Driver every time you print, check **Start Easy Eco Driver before printing job** checkbox in the **Basic** tab of the printing preference window.
- To use this feature on Stylish User Interface, click **Samsung Printer Center > Device Options** and then select **Stylish User Interface** (see "Using Samsung Printer Center" on page 262).

Using Samsung Printer Center



- Available for Windows users only.

The **Samsung Printer Center** allows you to manage all the printer drivers installed on your computer from a single integrated application. You can use the **Samsung Printer Center** to add and remove printer drivers, check the status of printers, update printer software, and configure printer driver settings.

Understanding Samsung Printer Center

To open the program:

For Windows,

Select **Start > Programs** or **All Programs > Samsung Printers > Samsung Printer Center**.

Printers tab



The screenshot may differ depending on operating system you are using.

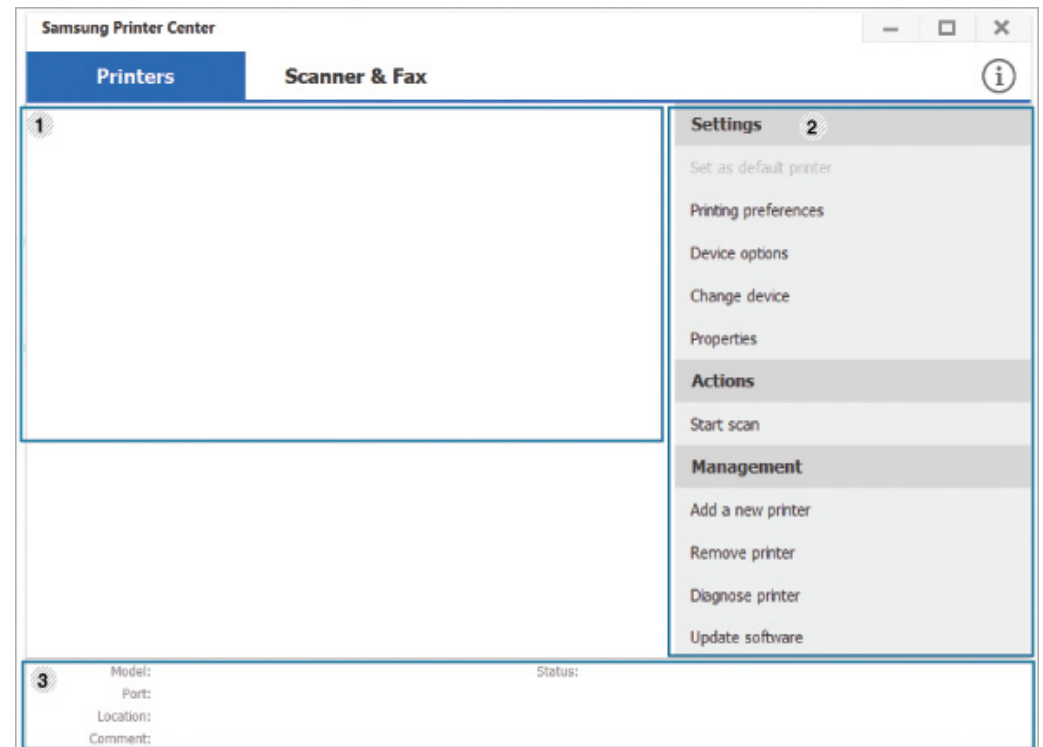

| | | |
|---|---------------------|---|
| 1 | Printer list | Displays the printer drivers installed on your computer. To add a printer driver to the list, click the  button. |
|---|---------------------|---|

Using Samsung Printer Center

Quick links

Displays links to various printer driver management functions. The quick links in the **Printers** tab link to the following functions:

- **Settings:** Allows you to configure the settings for individual printer driver.
 - **Set as default printer:** Sets the selected printer driver as the default printer. If the selected printer driver is already set as the default printer, then this option is not activated.
 - **Printing preferences:** Allows you to configure the default print settings.
 - **Device options:** Allows you to configure advanced options, such as the settings for optional devices and additional features.



The option allows you to modify the **Printer Status** and **Stylish User Interface** settings.

- **Change device:** Allows you to change the device into another device.
- **Properties:** Allows you to configure the printer driver properties, such as the name of the printer driver and its location, or add comments about the printer driver.
- **Actions:** Allows you to use the scan feature (this option is enabled only if the selected device supports the scan feature).
- **Management:** Allows you to manage the devices registered in the program.
 - **Add a new printer / Remove printer:** Adds a new device or removes an existing device.
 - **Diagnose printer:** Diagnoses problems in the selected device and suggests solutions.
 - **Update software:** Downloads and applies the applicable software updates.

Printer information

Provides general information about the selected device, such as its model, IP address, port number, and status.

Scanner & Fax Tab



- The screenshot may differ depending on operating system you are using.
- Available for multifunction products only.

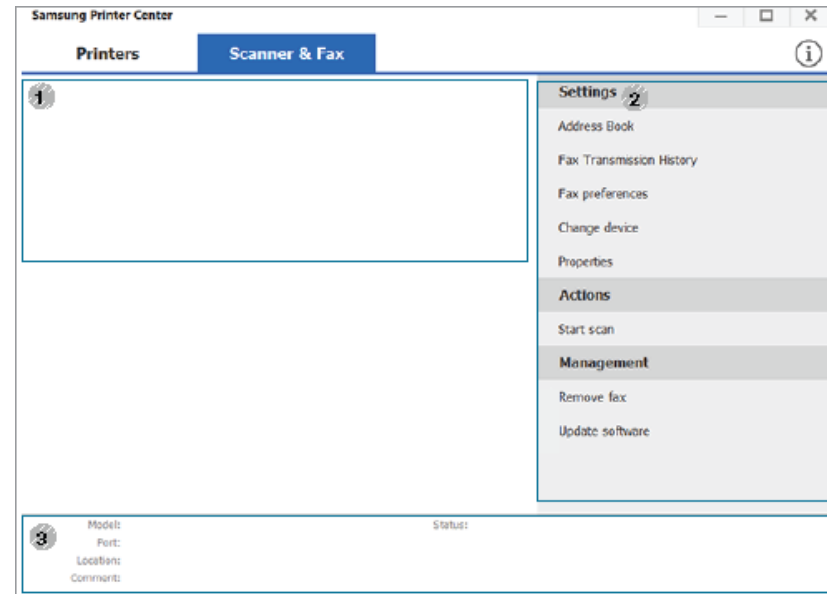

Printer list

Displays the fax and scanner driver installed on your computer. To add a fax or scanner driver to the list, click the



(Add Fax) or



(Add Scanner) button.

Using Samsung Printer Center

| | | |
|---|----------------------------|--|
| 2 | Quick links | <p>Displays links to the functions available for managing fax or scanner drivers. The quick links in the Scanner & Fax tab offer the following features:</p> <div data-bbox="309 363 1077 520" style="border: 1px solid #ccc; background-color: #f9f9f9; padding: 10px; margin: 10px 0;"> To use this feature, the scanner driver and fax driver must be installed on the computer.</div> <ul style="list-style-type: none">• Settings: Allows you to configure the settings for fax or scanner drivers.<ul style="list-style-type: none">- Address Book (fax only): Opens the Address Book.- Fax Transmission History (fax only): Opens the fax transmission history.- Fax preferences (fax only): Allows you to configure the default fax settings.- Change device: Allows you to change the devices into another device.- Properties: Allows you to configure the properties of a device, such as location and add comments about the device.• Actions: Allows you to use the scan feature.• Management: Allows you to manage the devices registered in the program.<ul style="list-style-type: none">- Remove fax or Remove scan: Removes the selected fax or scan driver.- Update software: Downloads and applies the applicable software updates. |
| 3 | Printer information | <p>Provides general information about the selected device, such as the model, IP address, port number, and machine status.</p> |

Using SyncThru™ Web Service



- Internet Explorer 6.0 or higher is the minimum requirement for SyncThru™ Web Service.
- SyncThru™ Web Service explanation in this user's guide may differ from your machine depending on its options or models.
- Network model only (see "Variety feature" on page 10).

Accessing SyncThru™ Web Service

- 1 Access a web browser, such as Internet Explorer, from Windows.
Enter the machine IP address of your printer (<http://xxx.xxx.xxx.xxx>) in the address field and press the Enter key or click **Go**.
- 2 Your machine's embedded website opens.

Logging into SyncThru™ Web Service

Before configuring options in SyncThru™ Web Service, you need to log-in as an administrator. You can still use SyncThru™ Web Service without logging in but you won't have access to **Settings** tab and **Security** tab.

- 1 Click **Login** on the upper right of the SyncThru™ Web Service website.
- 2 If it's your first time logging into **SyncThru™ Web Service** you need to log-in as an administrator. Type in the below default **ID** and **Password**. We recommend you to change the default password for security reasons.

•**ID: admin**

•**Password: sec00000**

SyncThru™ Web Service overview



Information

Settings

Security

Maintenance



Some tabs may not appear depending on your model.

Using SyncThru™ Web Service

Information tab

This tab gives you general information about your machine. You can check things, such as remaining amount of toner. You can also print reports, such as an error report.

- **Active Alerts:** Shows the alerts that have occurred in the machine and their severity.
- **Supplies:** Shows how many pages are printed and amount of toner left in the cartridge.
- **Usage Counters:** Shows the usage count by print types: simplex and duplex.
- **Current Settings:** Shows the machine's and network's information.
- **Print information:** Prints reports such as system related reports, e-mail address, and font reports.

Settings tab

This tab allows you to set configurations provided by your machine and network. You need to log-in as an administrator to view this tab.

- **Machine Settings tab:** Sets options provided by your machine.
- **Network Settings tab:** Shows options for the network environment. Sets options such as TCP/IP and network protocols.

Security tab

This tab allows you to set system and network security information. You need to log-in as an administrator to view this tab.

- **System Security:** Sets the system administrator's information and also enables or disables machine features.
- **Network Security:** Sets settings for IPv4/IPv6 filtering and Authentication servers.

Maintenance tab

This tab allows you to maintain your machine by upgrading firmware and setting contact information for sending emails. You can also connect to Samsung website or download drivers by selecting the **Link** menu.

- **Firmware Upgrade:** Upgrade your machine's firmware.
- **Contact Information:** Shows the contact information.
- **Link:** Shows links to useful sites where you can download or check information.

Using SyncThru™ Web Service

Setting the system administrator's information

This setting is necessary for using the e-mail notification option.



Some menus may not appear in the display depending on options or models. If so, it is not applicable to your machine.

- 1** Start a web browser, such as Internet Explorer, from Windows.
Enter the machine IP address (<http://xxx.xxx.xxx.xxx>) in the address field and press the Enter key or click **Go**.
- 2** Your machine's embedded website opens.
- 3** From the **Security** tab, select **System Security** > **System Administrator**
- 4** Enter the name of the administrator, phone number, location, and email address.
- 5** Click **Apply**.

Using Samsung Easy Printer Manager



- Available for Windows and Mac OS users only.
- For Windows, Internet Explorer 6.0 or higher is the minimum requirement for Samsung Easy Printer Manager.

Samsung Easy Printer Manager is an application that combines Samsung machine settings into one location. Samsung Easy Printer Manager combines device settings as well as printing environments, settings/actions and launching. All of these features provide a gateway to conveniently use your Samsung machine. Samsung Easy Printer Manager provides two different user interfaces for the user to choose from: the basic user interface and the advanced user interface. Switching between the two interfaces is easy: just click a button.

Understanding Samsung Easy Printer Manager

To open the program:

For Windows,

Select **Start > Programs** or **All Programs > Samsung Printers > Samsung Easy Printer Manager**.

For Mac,

Open the **Applications** folder > **Samsung** folder > **Samsung Easy Printer Manager**.

The Samsung Easy Printer Manager interface is comprised of various basic sections as described in the table that follows:





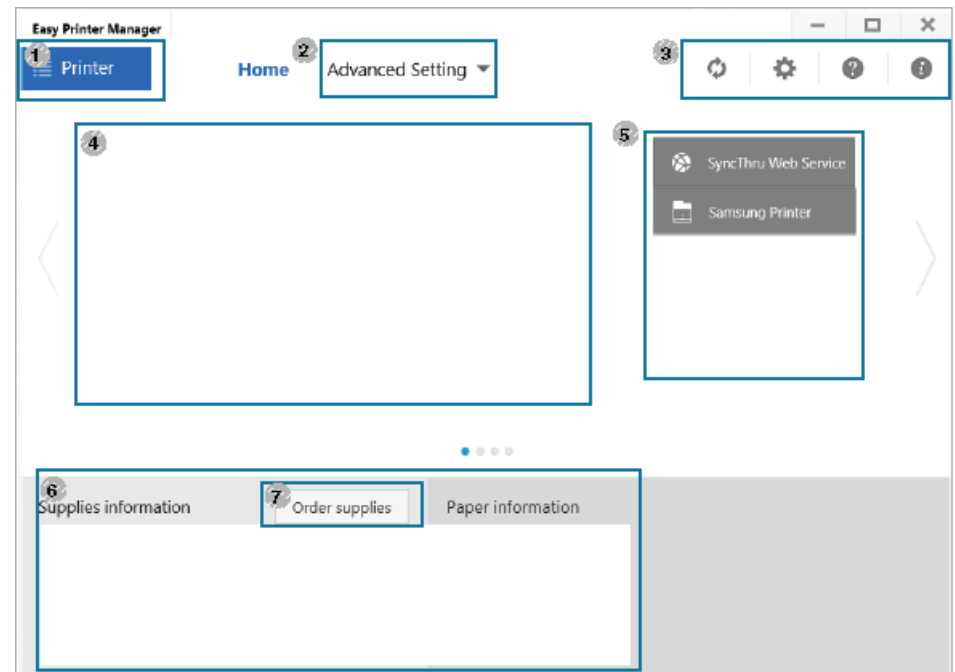

The screenshot may differ depending on operating system you are using.



| | | |
|---|---------------------|---|
| 1 | Printer list | The Printer list displays printers installed on your computer and network printers added by network discovery (Windows only). |
|---|---------------------|---|

Using Samsung Easy Printer Manager

| | | |
|---|-------------------------|---|
| 2 | Advanced Setting | <p>The advanced user interface is intended to be used by the person responsible for managing the network and machines.</p> <div data-bbox="313 319 1075 510">  <p>Some menus may not appear in the display depending on options or models. If so, it is not applicable to your machine.</p> </div> <ul style="list-style-type: none"> • Device Settings: You can configure various machine settings such as machine setup, paper, layout, emulation, network, and print information. <div data-bbox="313 686 1075 845">  <p>If you connect your machine to a network, the SyncThru™ Web Service icon is enabled.</p> </div> <ul style="list-style-type: none"> • Scan to PC Settings: This menu includes settings to create or delete scan to PC profiles. <ul style="list-style-type: none"> - Scan Activation: Determines whether or not scanning is enabled on the device. - Basic tab: Contains settings related general scan and device settings. • Alert Settings (Windows only): This menu includes settings related to error alerting. <ul style="list-style-type: none"> - Printer Alert: Provides settings related to when alerts will be received. - Email Alert: Provides options relating to receiving alerts via email. - Alert History: Provides a history of device and toner related alerts. |
|---|-------------------------|---|

| | | |
|---|--------------------------------|--|
| 3 | Application information | Includes links for changing to the refresh, preference setting, help, and about. |
| 4 | Printer information | <p>This area gives you general information about your machine. You can check information, such as the machine's model name, IP address (or Port name), and machine status.</p> <div data-bbox="1422 446 2184 638">  <p>This button opens the Troubleshooting Guide when an error occurs. You can directly open the troubleshooting section in the user's guide.</p> </div> |
| 5 | Quick links | <p>Displays Quick links to machine specific functions. This section also includes links to applications in the advanced settings.</p> <div data-bbox="1422 821 2184 981">  <p>If you connect your machine to a network, the SyncThru™ Web Service icon is enabled.</p> </div> |
| 6 | Contents area | Displays information about the selected machine, remaining toner level, and paper. The information will vary based on the machine selected. Some machines do not have this feature. |
| 7 | Order supplies | Click on the Order button from the supply ordering window. You can order replacement toner cartridge(s) from online. |



Select the **Help** menu or click the  button from the window and click on any option you want to know about.

Using Samsung Easy Document Creator



- Available for Windows and Mac OS users only.
- Windows® XP Service Pack 3 or higher and Internet Explorer 6.0 or higher is the minimum requirement for Samsung Easy Document Creator.

Samsung Easy Document Creator is an application to help users scan, compile, and save documents in multiple formats, including .epub format. These documents can be shared via social networking sites or fax. Whether you're a student needing to organize research from the library or a stay-at-home mom sharing scanned pictures from last year's birthday party, Samsung Easy Document Creator will provide you with the necessary tools.

The Samsung Easy Document Creator provides features mentioned below:

- **Scan:** Use for scanning pictures or documents.
- **Text Converting Scan(Windows only):** Use for scanning documents that need to be saved in an editable text format.
- **Document Conversion:** Provides the ability to convert existing files into multiple formats.
- **Fax:** Provides the ability to directly fax a document from Easy Document Creator if the Samsung network PC fax driver is installed.

Using Samsung Printer Status

The Samsung Printer Status is a program that monitors and informs you of the machine status.



- The Samsung Printer Status window and its contents shown in this user's guide may differ depending on the machine or operating system in use.
- Check the operating system(s) that are compatible with your machine (see "Specifications" on page 125).
- Available for Windows OS users only (see "Software" on page 8).

Samsung Printer Status overview

If an error occurs while operating, you can check the error from the Samsung Printer Status. Samsung Printer Status is installed automatically when you install the machine software.

You can also launch Samsung Printer Status manually. Go to the **Printing Preferences**, click the **Basic** tab > **Printer Status** button.

These icons appear on the Windows task bar:

| Icon | Mean | Description |
|------|---------|---|
| | Normal | The machine is in ready mode and experiencing no errors or warnings. |
| | Warning | The machine is in a state where an error might occur in the future. For example, it might be in toner low status, which may lead to toner empty status. |
| | Error | The machine has at least one error. |

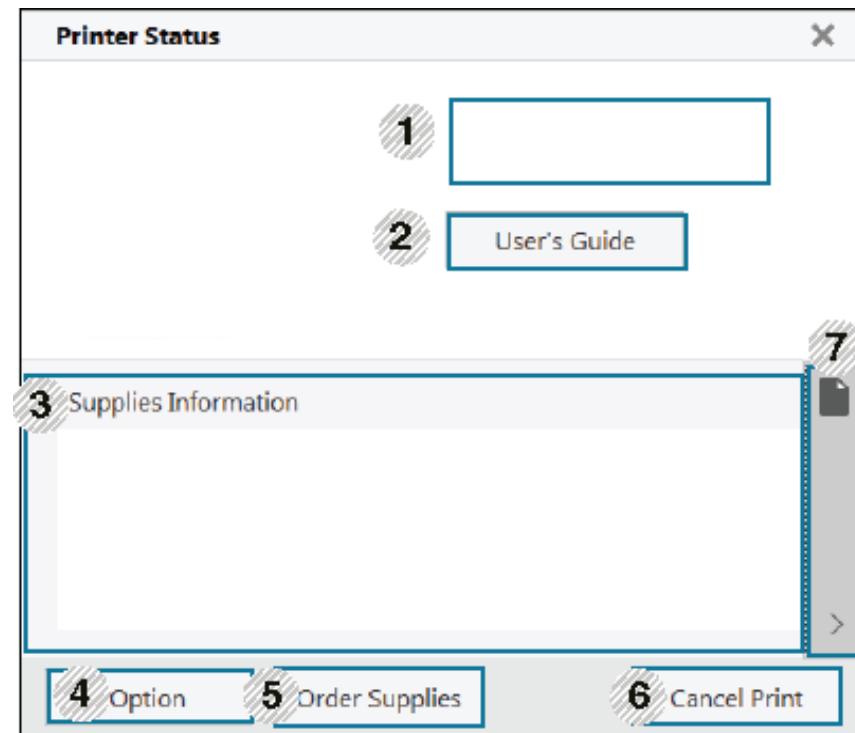

Using Samsung Printer Status

| | | |
|---|---|--|
| 1 | Device Information | You can see the device status , current printer model name, connected port name in this area. |
| 2 | User's Guide | <p>You can view the online User's Guide.</p> <div style="border: 1px solid #ccc; padding: 10px; margin: 10px 0;">  This button opens the Troubleshooting Guide when an error occurs. You can directly open the troubleshooting section in the user's guide. </div> |
| 3 | Supplies Information | You can view the percentage of toner remaining in each toner cartridge. The machine and the number of toner cartridge(s) shown in the above window may differ depending on the machine in use. Some machines do not have this feature. |
| 4 | Option | You can set printing job alert related settings. |
| 5 | Order Supplies | You can order replacement toner cartridge(s) from online. |
| 6 | Cancel Print or Close | <ul style="list-style-type: none"> • Cancel Print : If print job is waiting in the print queue or printer, cancel all user's print jobs in the print queue or the printer. • Close : Depending on the status of the machine or the supported functions, the Close button may appear to close the status window. |

| | | |
|---|--------------------------------|---|
| 7 | Toner/Paper Information | This button areas for paper and toner info will be available based on the device. |
|---|--------------------------------|---|

Using Samsung Printer Experience

Samsung Printer Experience is a Samsung application that combines Samsung machine settings and machine management into one location. You can set device settings, order supplies, open troubleshooting guides, visit Samsung's web site, and check connected machine information. This application will be automatically downloaded from the Windows **Store** if the machine is connected to a computer with an Internet connection.

Understanding the Samsung Printer Experience

To open the application,

From the **Start** screen, select the **Samsung Printer Experience** () tile.

The **Samsung Printer Experience** interface comprises various useful features as described in the following table:



The screenshot may differ depending on the model you are using.

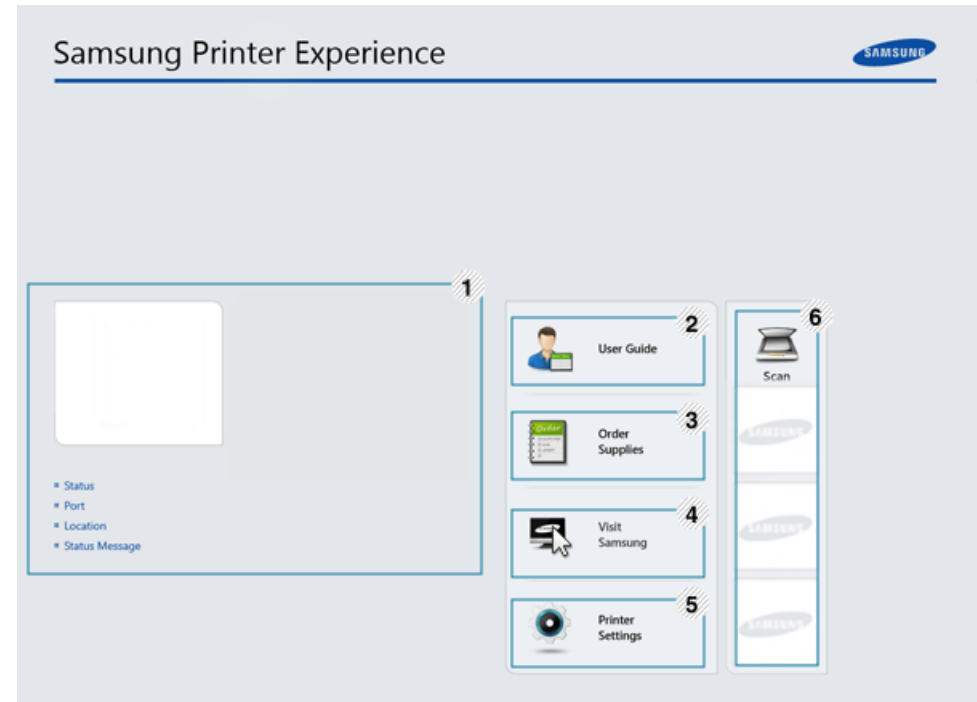

| | | |
|---|----------------------------|---|
| 1 | Printer Information | This area gives you general information about your machine. You can check information, such as the machine's status, location, IP address, and remaining toner level. |
|---|----------------------------|---|

Using Samsung Printer Experience

| | | |
|---|---|--|
| 2 | User Guide | You can view the online User's Guide. You need to be connected to the Internet to use this feature.  This button opens the Troubleshooting Guide when an error occurs. You can directly open the troubleshooting section in the user's guide. |
| 3 | Order Supplies | Click on this button to order replacement toner cartridges online. You need to be connected to the Internet to use this feature. |
| 4 | Visit Samsung | Links to Samsung printer website. You need to be connected to the Internet to use this feature. |
| 5 | Printer Settings | You can configure various machine settings such as machine setup, paper, layout, emulation, networking, and print information through SyncThru™ Web Service . Your machine needs to be connected to a network. This button will be disabled if your machine is connected via USB cable. |
| 6 | Device List & Latest Scanned Image | The scan list displays devices that supports Samsung Printer Experience . Under the device, you can see the latest scanned images. Your machine needs to be connected to a network to scan from here. This section is for the users with multi-functional printers. |

Adding/Deleting Printers

If you do not have any printer added to the **Samsung Printer Experience**, or if you want to add/delete a printer, follow the instructions below.



You can only add/delete network connected printers.

Adding a printer

- 1 From the **Charms**, select **Settings**.
Or, right-click the **Samsung Printer Experience** page and select **Settings**.
- 2 Select **Add Printer**
- 3 Select the printer you want to add.
You can see the added printer.



If you see  mark, you can also click  mark to add printers.

Using Samsung Printer Experience

Deleting a printer

- 1 From the **Charms**, select **Settings**.
Or, right-click the **Samsung Printer Experience** page and select **Settings**.
- 2 Select **Remove Printer**.
- 3 Select the printer you want to delete.
- 4 Click **Yes**.
You can see that the deleted printer is removed from the screen.

Printing from Windows 8

This section explains common printing tasks from the **Start** screen.

Basic printing

- 1 Open the document to print.
- 2 From the **Charms**, select **Devices**.
- 3 Select your printer from the list

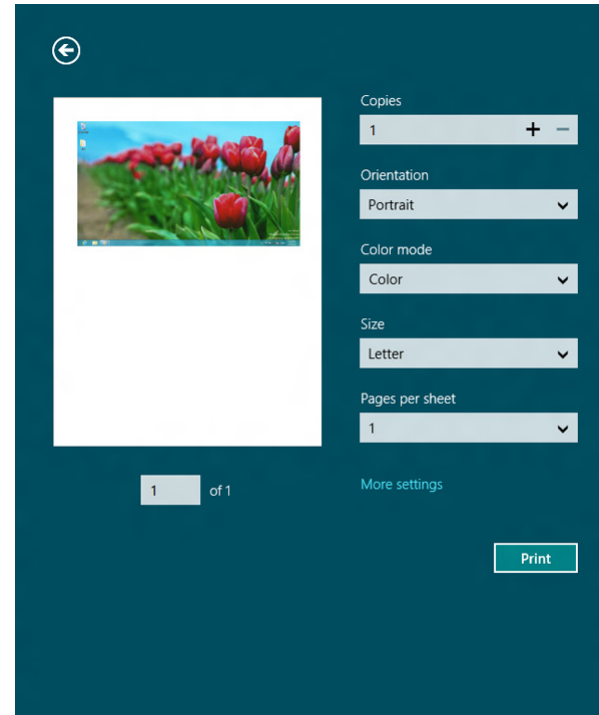

- 4 Select the printer settings, such as the number of copies and orientation.
- 5 Click the **Print** button to start the print job.



Using Samsung Printer Experience

Canceling a print job

If the printing job is waiting in the print queue or print spooler, cancel the job as follows:

- You can access this window by simply double-clicking the machine icon () in the Windows task bar.
- You can also cancel the current job by pressing  (**Stop/Clear**) button on the control panel.

Opening more settings



The screen may appear somewhat different depending on the model or options.

You can set up more printing parameters.

- 1 Open the document you want to print.
- 2 From the **Charms**, select **Devices**.
- 3 Select your printer from the list
- 4 Click **More settings**.

Basic tab

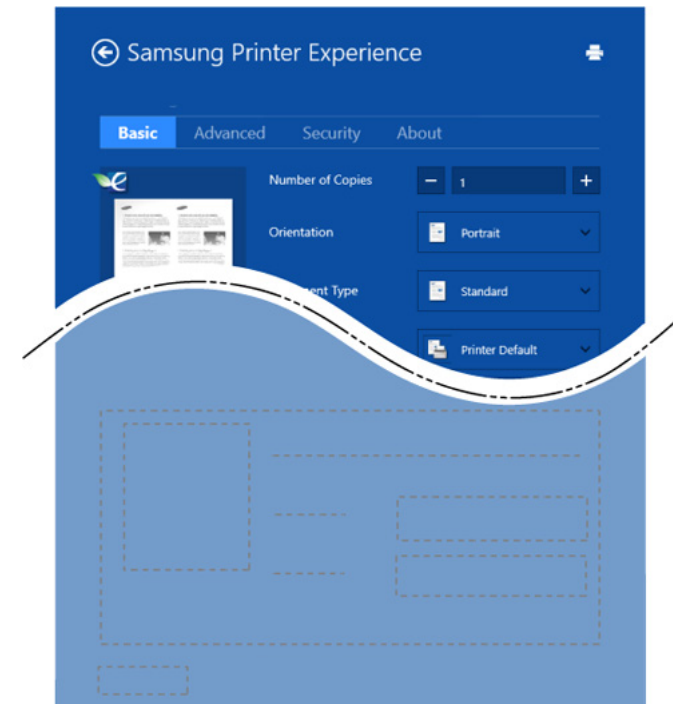

Basic

This option allows you to choose the basic printing settings such as copies, orientation, and document type.

Eco settings

This option allows you to choose multiple pages per side to save media.

Using Samsung Printer Experience

Advanced tab

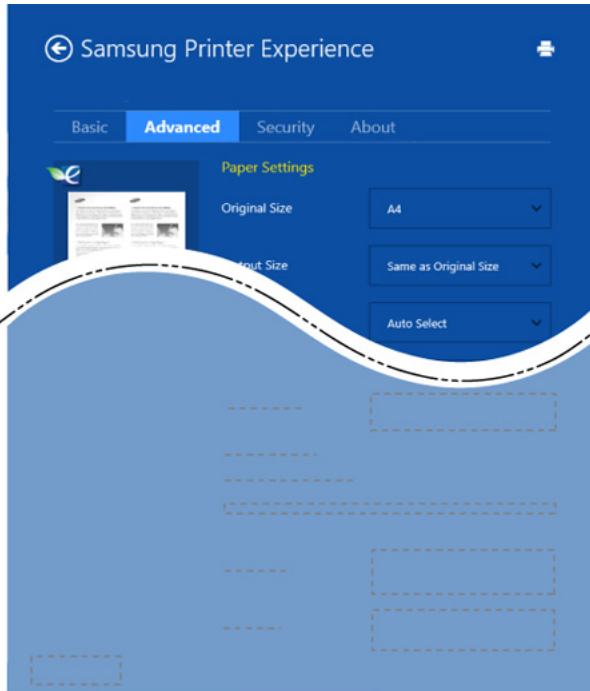

Paper settings

This option allows you to set the basic paper handling specifications.

Layout settings

This option allows you to set the various ways to layout your documents.

Security tab



Some features may not be available depending on the model or options. If this tab is not shown or disabled, it means that these features are not supported.

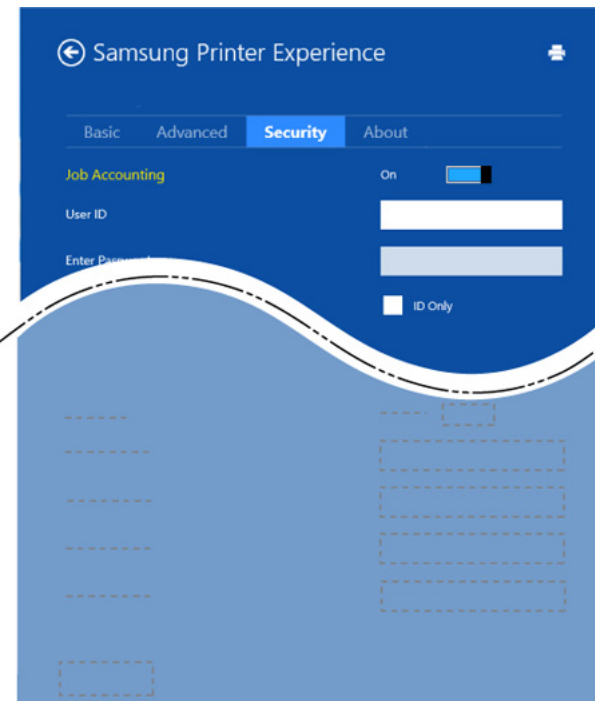

Job Accounting

This option allows you to print with the given permission.

Confidential Printing

Using Samsung Printer Experience

This option is used for printing confidential documents. You need to enter a password to print using it.

Using the sharing feature

Samsung Printer Experience allows you to print from other applications installed on the computer using the sharing feature.



This feature is only available for printing jpeg, bmp, tiff, gif, and png file formats.

- 1 Select the content you want to print from other application.
- 2 From the **Charms**, select **Share > Samsung Printer Experience**.
- 3 Select the printer settings, such as the number of copies and orientation.
- 4 Click the **Print** button to start the print job.

Scanning from Windows 8





This section is for the users with multi-functional printers.

Scanning with your machine lets you turn pictures and text into digital files that can be stored on your computer.

Scanning from Samsung Printer Experience

The most frequently used printing menus are displayed for quick scanning.

- 1 Place a single document face down on the document glass, or load the documents face up into the document feeder.
- 2 Click the **Samsung Printer Experience** tile on the **Start** screen.
- 3 Click **Scan** () .
- 4 Set up the scanning parameters such as image type, document size, and resolution.
- 5 Click **Prescan** () to check the image.
- 6 Adjust the prescanned image with scanning operation functions such as rotate and mirror.
- 7 Click **Scan** () and save the image.



- When you place the originals in the ADF (or DADF), **Prescan** () is not available.
- You can skip step 5, if the Prescan option is selected.



6. Troubleshooting

This chapter gives helpful information for what to do if you encounter an error.

- **Paper feeding problems** 283
- **Power and cable connecting problems** 284
- **Printing problems** 285
- **Printing quality problems** 289
- **Copying problems** 297
- **Scanning problems** 298
- **Faxing problems** 299
- **Operating system problems** 301



For errors that occur during the wireless software installation and settings, refer to the troubleshooting section in the wireless setting chapter (see "Troubleshooting for wireless network" on page 182).

Paper feeding problems

| Condition | Suggested solutions |
|--|---|
| Paper jams during printing. | Clear the paper jam. |
| Paper sticks together. | <ul style="list-style-type: none">• Check the maximum paper capacity of the tray.• Make sure that you are using the correct type of paper.• Remove paper from the tray and flex or fan the paper.• Humid conditions may cause some paper to stick together. |
| Multiple sheets of paper do not feed. | Different types of paper may be stacked in the tray. Load paper of only one type, size, and weight. |
| Paper does not feed into the machine. | <ul style="list-style-type: none">• Remove any obstructions from inside the machine.• Paper has not been loaded correctly. Remove paper from the tray and reload it correctly.• There is too much paper in the tray. Remove excess paper from the tray.• The paper is too thick. Use only paper that meets the specifications required by the machine. |
| The paper keeps jamming. | <ul style="list-style-type: none">• There is too much paper in the tray. Remove excess paper from the tray. If you are printing on special materials, use the manual feeding in tray.• An incorrect type of paper is being used. Use only paper that meets the specifications required by the machine.• There may be debris inside the machine. Open the front cover and remove any debris. |

Power and cable connecting problems

Reboot the power. If the problem persists, please call for service.

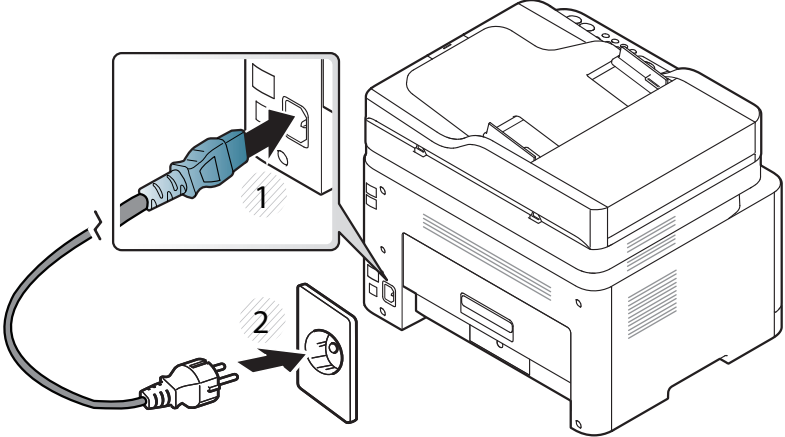
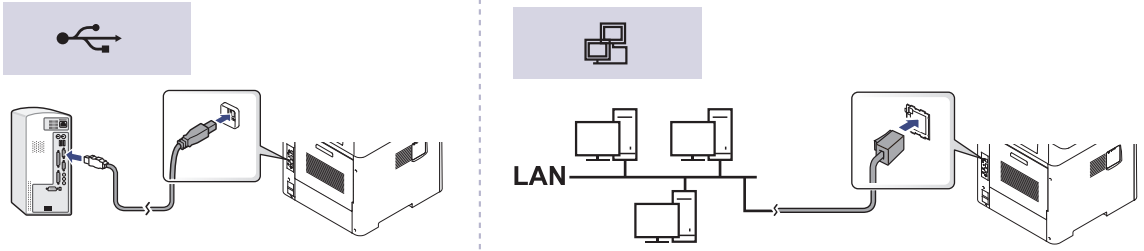
| Condition | Suggested solutions |
|---|---|
| <p>The machine is not receiving power, or the connection cable between the computer and the machine is not connected properly.</p> | <p>1 Connect the machine to the electricity supply first.</p>  <p>2 Check the USB cable or network cable in the machine's rear.</p>  <p>3 Disconnect the USB cable or network cable in the machine's rear and then, reconnect it.</p> |

Printing problems

| Condition | Possible cause | Suggested solutions |
|------------------------------------|--|---|
| The machine does not print. | The machine is not receiving power. | Connect the machine to the electricity supply first. If the machine has a  (Power/Wake Up) button on the control, press it. |
| | The machine is not selected as the default machine. | Select your machine as your default machine in Windows. |
| | Check the machine for the following: <ul style="list-style-type: none">• The cover is not closed. Close the cover.• Paper is jammed. Clear the paper jam (see "Clearing paper jams" on page 108).• No paper is loaded. Load paper (see "Loading paper in the tray" on page 42).• The toner cartridge is not installed. Install the toner cartridge (see "Replacing the toner cartridge" on page 87).• Make sure the protect cover and sheets are removed from the toner cartridge (see "Replacing the toner cartridge" on page 87). If a system error occurs, contact your service representative. | |
| | The connection cable between the computer and the machine is not connected properly. | Disconnect the machine cable and reconnect it (see "Rear view" on page 23). |
| | The connection cable between the computer and the machine is defective. | If possible, attach the cable to another computer that is working properly and print a job. You can also try using a different machine cable. |
| | The port setting is incorrect. | Check the Windows printer settings to make sure that the print job is sent to the correct port. If the computer has more than one port, make sure that the machine is attached to the correct one. |

Printing problems

| Condition | Possible cause | Suggested solutions |
|---|---|---|
| The machine does not print. | The machine may be configured incorrectly. | Check the Printing Preferences to ensure that all of the print settings are correct. |
| | The printer driver may be incorrectly installed. | Uninstall and reinstall the machine's driver. |
| | The machine is malfunctioning. | Check the display message on the control panel to see if the machine is indicating a system error. Contact a service representative. |
| | The document size is so big that the hard disk space of the computer is insufficient to access the print job. | Get more hard disk space and print the document again. |
| | The output tray is full. | Once the paper is removed from the output tray, the machine resumes printing. |
| The machine selects print materials from the wrong paper source. | The paper option that was selected in the Printing Preferences may be incorrect. | For many software applications, the paper source selection is found under the Paper tab within the Printing Preferences (see "Opening printing preferences" on page 56). Select the correct paper source. See the printer driver help screen (see "Using help" on page 57). |
| A print job is extremely slow. | The job may be very complex. | Reduce the complexity of the page or try adjusting the print quality settings. |
| Half the page is blank. | The page orientation setting may be incorrect. | Change the page orientation in your application (see "Opening printing preferences" on page 56). See the printer driver help screen (see "Using help" on page 57). |
| | The paper size and the paper size settings do not match. | Ensure that the paper size in the printer driver settings matches the paper in the tray. Or, ensure that the paper size in the printer driver settings matches the paper selection in the software application settings you use (see "Opening printing preferences" on page 56). |

Printing problems

| Condition | Possible cause | Suggested solutions |
|--|--|---|
| The machine prints, but the text is wrong, garbled, or incomplete. | The machine cable is loose or defective. | Disconnect the machine cable and reconnect. Try a print job that you have already printed successfully. If possible, attach the cable and the machine to another computer that you know works and try a print job. Finally, try a new machine cable. |
| | The wrong printer driver was selected. | Check the application's printer selection menu to ensure that your machine is selected. |
| | The software application is malfunctioning. | Try printing a job from another application. |
| | The operating system is malfunctioning. | Exit Windows and reboot the computer. Turn the machine off and back on again. |
| Pages print, but they are blank. | The toner cartridge is defective or out of toner. | Redistribute the toner, if necessary. If necessary, replace the toner cartridge. <ul style="list-style-type: none">• See "Redistributing toner" on page 85.• See "Replacing the toner cartridge" on page 87. |
| | The file may have blank pages. | Check the file to ensure that it does not contain blank pages. |
| | Some parts, such as the controller or the board, may be defective. | Contact a service representative. |
| The machine does not print PDF files correctly. Some parts of graphics, text, or illustrations are missing. | Incompatibility between the PDF file and the Acrobat products. | Printing the PDF file as an image may enable the file to print. Turn on Print As Image from the Acrobat printing options.  It will take longer to print when you print a PDF file as an image. |
| The print quality of photos is not good. Images are not clear. | The resolution of the photo is very low. | Reduce the photo size. If you increase the photo size in the software application, the resolution will be reduced. |

Printing problems

| Condition | Possible cause | Suggested solutions |
|---|---|--|
| Before printing, the machine emits vapor near the output tray. | Using damp paper can cause vapor during printing. | This is not a problem. Just keep printing. |
| The machine does not print special-sized paper, such as billing paper. | Paper size and paper size setting do not match. | Set the correct paper size in the Custom in Paper tab in Printing Preferences (see "Opening printing preferences" on page 56). |
| The printed billing paper is curled. | The paper type setting does not match. | Change the printer option and try again. Go to Printing Preferences , click Paper tab, and set type to Thick (see "Opening printing preferences" on page 56). |

Printing quality problems

If the inside of the machine is dirty or paper has been loaded improperly, there might be a reduction in print quality. See the table below to clear the problem.

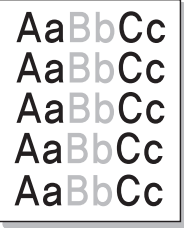
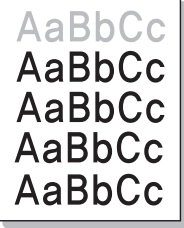
| Condition | Suggested solutions |
|---|---|
| <p data-bbox="51 357 322 389">Light or faded print</p>  | <ul data-bbox="506 357 2186 842" style="list-style-type: none">• If a vertical white streak or faded area appears on the page, the toner supply is low. Install a new toner cartridge (see "Replacing the toner cartridge" on page 87).• If a vertical white streak or faded area still appears on the page even though the machine has enough toner supply, open and close the front door 3 ~ 4 times (see "Machine overview" on page 20).• The paper may not meet paper specifications; for example, the paper may be too moist or rough.• If the entire page is light, the print resolution setting is too low or the toner save mode is on. Adjust the print resolution and turn the toner save mode off. See the help screen of the printer driver.• A combination of faded or smeared defects may indicate that the toner cartridge needs cleaning. Clean the inside of your machine (see "Cleaning the machine" on page 95).• The surface of the LSU part inside the machine may be dirty. Clean the inside of your machine (see "Cleaning the machine" on page 95). If these steps do not correct the problem, contact a service representative. |
| <p data-bbox="51 879 472 991">The top half of the paper is printed lighter than the rest of the paper</p>  | <p data-bbox="506 879 1301 911">The toner might not adhere properly to this type of paper.</p> <ul data-bbox="506 935 2186 1002" style="list-style-type: none">• Change the printer option and try again. Go to Printing Preferences, click the Paper tab, and set the paper type to Recycled (see "Opening printing preferences" on page 56). |

Printing quality problems

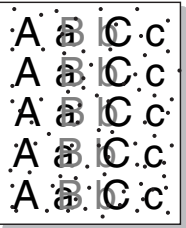
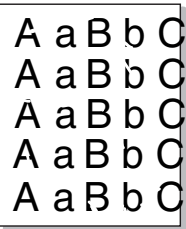
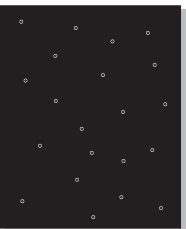
| Condition | Suggested solutions |
|--|--|
| <p>Toner specks</p>  | <ul style="list-style-type: none">• The paper may not meet specifications; for example, the paper may be too moist or rough.• The transfer roller may be dirty. Clean the inside of your machine (see "Cleaning the machine" on page 95).• The paper path may need cleaning. Contact a service representative (see "Cleaning the machine" on page 95). |
| <p>Dropouts</p>  | <p>If faded areas, generally rounded, occur randomly on the page:</p> <ul style="list-style-type: none">• A single sheet of paper may be defective. Try reprinting the job.• The moisture content of the paper is uneven or the paper has moist spots on its surface. Try a different brand of paper.• The paper lot is bad. The manufacturing processes can cause some areas to reject toner. Try a different kind or brand of paper.• Change the printer option and try again. Go to Printing Preferences, click the Paper tab, and set type to Thick (see "Opening printing preferences" on page 56). <p>If these steps do not correct the problem, contact a service representative.</p> |
| <p>White Spots</p>  | <p>If white spots appear on the page:</p> <ul style="list-style-type: none">• The paper is too rough and a lot of dirt from paper falls to the inner components within the machine, so the transfer roller may be dirty. Clean the inside of your machine (see "Cleaning the machine" on page 95).• The paper path may need cleaning. Clean the inside of your machine (see "Cleaning the machine" on page 95). <p>If these steps do not correct the problem, contact a service representative.</p> |

Printing quality problems

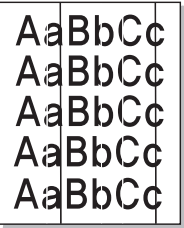
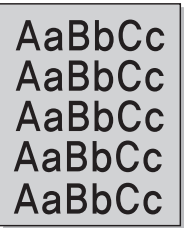
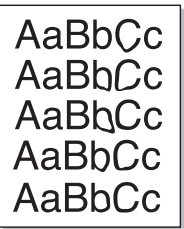
| Condition | Suggested solutions |
|--|--|
| <p>Vertical lines</p>  | <p>If black vertical streaks appear on the page:</p> <ul style="list-style-type: none">• The surface (drum part) of the imaging unit inside the machine has probably been scratched. Remove the imaging unit and install a new one (see "Replacing the imaging unit" on page 89). <p>If white vertical streaks appear on the page:</p> <ul style="list-style-type: none">• The surface of the LSU part inside the machine may be dirty. Clean the inside of your machine (see "Cleaning the machine" on page 95). If these steps do not correct the problem, contact a service representative. |
| <p>Black or color background</p>  | <p>If the amount of background shading becomes unacceptable:</p> <ul style="list-style-type: none">• Change to a lighter weight paper.• Check the environmental conditions: very dry conditions or a high level of humidity (higher than 80% RH) can increase the amount of background shading.• Remove the old imaging unit and install a new one (see "Replacing the imaging unit" on page 89).• Thoroughly redistribute the toner (see "Redistributing toner" on page 85). |
| <p>Toner smear</p>  | <ul style="list-style-type: none">• Clean the inside of the machine (see "Cleaning the machine" on page 95).• Check the paper type and quality.• Remove the imaging unit and install a new one (see "Replacing the imaging unit" on page 89). |

Printing quality problems

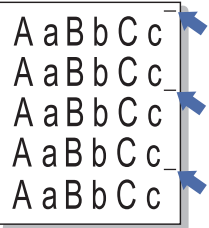
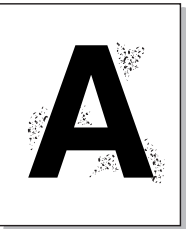
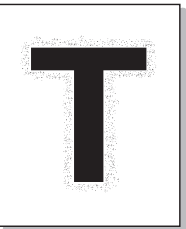
| Condition | Suggested solutions |
|---|--|
| <p data-bbox="51 272 405 304">Vertical repetitive defects</p>  | <p data-bbox="506 272 1473 304">If marks repeatedly appear on the printed side of the page at even intervals:</p> <ul data-bbox="506 328 2190 544" style="list-style-type: none"><li data-bbox="506 328 2190 400">• The imaging unit may be damaged. If you still have the same problem, remove the imaging unit and, install a new one (see "Replacing the imaging unit" on page 89).<li data-bbox="506 416 2190 488">• Parts of the machine may have toner on them. If the defects occur on the back of the page, the problem will likely correct itself after a few more pages.<li data-bbox="506 504 1462 544">• The fusing assembly may be damaged. Contact a service representative. |
| <p data-bbox="51 612 322 644">Background scatter</p>  | <p data-bbox="506 612 1621 644">Background scatter results from bits of toner randomly distributed on the printed page.</p> <ul data-bbox="506 668 2190 924" style="list-style-type: none"><li data-bbox="506 668 2190 740">• The paper may be too damp. Try printing with a different batch of paper. Do not open packages of paper until necessary so that the paper does not absorb too much moisture.<li data-bbox="506 756 2190 876">• If background scatter covers the entire surface area of a printed page, adjust the print resolution through your software application or in Printing Preferences (see "Opening printing preferences" on page 56). Ensure the correct paper type is selected. For example: If Thicker Paper is selected, but Plain Paper actually used, an overcharging can occur causing this copy quality problem.<li data-bbox="506 892 1872 924">• If you are using a new toner cartridge, redistribute the toner first (see "Redistributing toner" on page 85). |
| <p data-bbox="51 954 479 1026">Toner particles are around bold characters or pictures</p>  | <p data-bbox="506 954 1249 986">The toner might not adhere properly to this type of paper.</p> <ul data-bbox="506 1010 2190 1169" style="list-style-type: none"><li data-bbox="506 1010 2190 1082">• Change the printer option and try again. Go to Printing Preferences, click the Paper tab, and set the paper type to Recycled (see "Opening printing preferences" on page 56).<li data-bbox="506 1098 2190 1169">• Ensure the correct paper type is selected. For example: If Thicker Paper is selected, but Plain Paper actually used, an overcharging can occur causing this copy quality problem. |

Printing quality problems

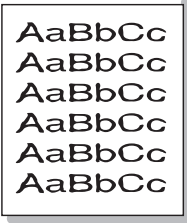
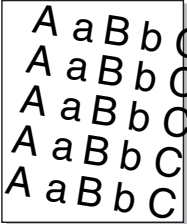
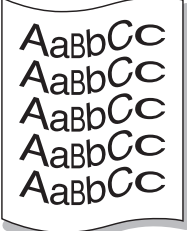
| Condition | Suggested solutions |
|--|--|
| <p data-bbox="49 272 353 304">Misformed characters</p>  | <ul data-bbox="504 272 2072 304" style="list-style-type: none">• If characters are improperly formed and producing hollow images, the paper stock may be too slick. Try different paper. |
| <p data-bbox="49 608 203 639">Page skew</p>  | <ul data-bbox="504 608 1518 743" style="list-style-type: none">• Ensure that the paper is loaded properly.• Check the paper type and quality.• Ensure that the guides are not too tight or too loose against the paper stack. |
| <p data-bbox="49 951 226 983">Curl or wave</p>  | <ul data-bbox="504 951 1729 1086" style="list-style-type: none">• Ensure that the paper is loaded properly.• Check the paper type and quality. Both high temperature and humidity can cause paper curl.• Turn the stack of paper over in the tray. Also try rotating the paper 180° in the tray. |

Printing quality problems

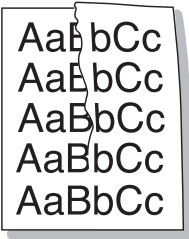
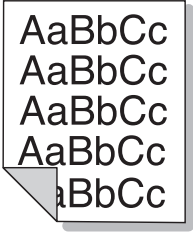
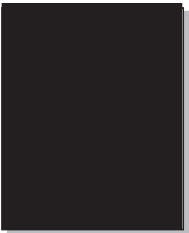
| Condition | Suggested solutions |
|---|---|
| <p data-bbox="49 272 320 304">Wrinkles or creases</p>  | <ul data-bbox="506 272 1597 411" style="list-style-type: none">• Ensure that the paper is loaded properly.• Check the paper type and quality.• Turn the stack of paper over in the tray. Also try rotating the paper 180° in the tray. |
| <p data-bbox="49 619 412 651">Back of printouts are dirty</p>  | <ul data-bbox="506 619 1787 651" style="list-style-type: none">• Check for leaking toner. Clean the inside of the machine (see "Cleaning the machine" on page 95). |
| <p data-bbox="49 986 405 1018">Solid color or black pages</p>  | <ul data-bbox="506 986 2197 1125" style="list-style-type: none">• The imaging unit may not be installed properly. Remove the imaging unit and reinsert it.• The imaging unit may be defective. Remove the imaging unit and install a new one (see "Replacing the imaging unit" on page 89).• The machine may require repairing. Contact a service representative. |

Printing quality problems

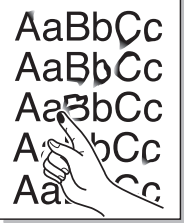
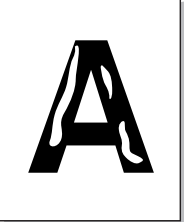
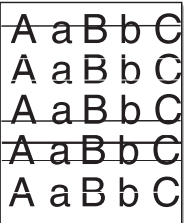
| Condition | Suggested solutions |
|---|--|
| <p>Loose toner</p>  | <ul style="list-style-type: none">• Clean the inside of the machine (see "Cleaning the machine" on page 95).• Check the paper type and quality.• Remove the imaging unit and then, install a new one (see "Replacing the toner cartridge" on page 87). <p>If the problem persists, the machine may require repair. Contact a service representative.</p> |
| <p>Character voids</p>  | <p>Character voids are white areas within parts of characters that should be solid black:</p> <ul style="list-style-type: none">• You may be printing on the wrong surface of the paper. Remove the paper and turn it around.• The paper may not meet paper specifications. |
| <p>Horizontal stripes</p>  | <p>If horizontally aligned black streaks or smears appear:</p> <ul style="list-style-type: none">• The imaging unit may be installed improperly. Remove the imaging unit and reinsert it.• The imaging unit may be defective. Remove the imaging unit and install a new one (see "Replacing the imaging unit" on page 89). <p>If the problem persists, the machine may require repairing. Contact a service representative.</p> |

Printing quality problems

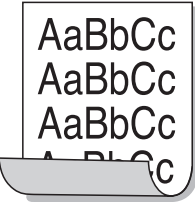
| Condition | Suggested solutions |
|---|---|
| <p>Curl</p>  | <p>If the printed paper is curled or paper does not feed into the machine:</p> <ul style="list-style-type: none">• Turn the stack of paper over in the tray. Also try rotating the paper 180° in the tray.• Change the printer's paper option and try again. Go to Printing Preferences, click the Paper tab, and set type to Thin (see "Opening printing preferences" on page 56). |
| <ul style="list-style-type: none">• An unknown image repetitively appears on a few sheets• Loose toner• Light print or contamination occurs | <p>Your machine is probably being used at an altitude of 1,000 m (3,281 ft) or above. The high altitude may affect the print quality, such as loose toner or light imaging. Change the altitude setting for your machine (see "Altitude adjustment" on page 225).</p> |

Copying problems

| Condition | Suggested solutions |
|---|---|
| Copies are too light or too dark. | Adjust the darkness in copy feature to lighten or darken the backgrounds of copies (see "Changing the settings for each copy" on page 60). |
| Smears, lines, marks, or spots appear on copies. | <ul style="list-style-type: none">• If the defects are on the original, adjust darkness in copy feature to lighten the background of your copies.• Adjust background in copy setup removes the background color (see "Adjust Bkgd." on page 208).• If there are no defects on the original, clean the scan unit (see "Cleaning the scan unit" on page 98). |
| Copy image is skewed. | <ul style="list-style-type: none">• Ensure that the original is aligned with the registration guide.• The transfer roller may be dirty. Clean the inside of your machine (see "Cleaning the machine" on page 95). |
| Blank copies print out. | Ensure that the original is face down on the scanner glass or face up in the document feeder. If these steps do not correct the problem, contact a service representative. |
| Image rubs off the copy easily. | <ul style="list-style-type: none">• Replace the paper in the tray with paper from a new package.• In high humidity areas, do not leave paper in the machine for extended periods of time. |
| Frequent copy paper jams occur. | <ul style="list-style-type: none">• Fan the paper, then turn it over in the tray. Replace the paper in the tray with a fresh supply. Check/adjust the paper guides, if necessary.• Ensure that the paper is the proper type and weight (see "Print media specifications" on page 127).• Check for copy paper or pieces of copy paper remaining in the machine after a paper jam has been cleared. |
| Toner cartridge produces fewer copies than expected before running out of toner. | <ul style="list-style-type: none">• Your originals may contain pictures, solids, or heavy lines. For example, your originals may be forms, newsletters, books, or other documents that use more toner.• The scanner lid may be left open while copies are being made.• Turn the machine off and back on. |

Scanning problems

| Condition | Suggested solutions |
|---|--|
| The scanner does not work. | <ul style="list-style-type: none">• Make sure that you place the original to be scanned face down on the scanner glass, or face up in the document feeder (see "Loading originals" on page 50).• There may not be enough available memory to hold the document you want to scan. Try the Prescan function to see if that works. Try lowering the scan resolution rate.• Check that the machine printer cable is connected properly.• Make sure that the machine printer cable is not defective. Switch the printer cable with a known good cable. If necessary, replace the printer cable.• Check that the scanner is configured correctly. Check scan setting in the Easy Document Creator or the application you want to use to make certain that the scanner job is being sent to the correct port (for example, USB001). |
| The unit scans very slowly. | <ul style="list-style-type: none">• Check if the machine is printing received data. If so, scan the document after the received data has been printed.• Graphics are scanned more slowly than text. |
| Message appears on your computer screen: <ul style="list-style-type: none">• Device can't be set to the H/W mode you want.• Port is being used by another program.• Port is disabled.• Scanner is busy receiving or printing data. When the current job is completed, try again.• Invalid handle.• Scanning has failed. | <ul style="list-style-type: none">• There may be a copying or printing job in progress. Try your job again when that job is finished.• The selected port is currently being used. Restart your computer and try again.• The machine printer cable may be improperly connected or the power may be off.• The scanner driver is not installed or the operating environment is not set up properly.• Ensure that the machine is properly connected and the power is on, then restart your computer.• The USB cable may be improperly connected or the power may be off. |

Faxing problems

| Condition | Suggested solutions |
|---|---|
| The machine is not working, there is no display, or the buttons are not working. | <ul style="list-style-type: none">• Unplug the power cord and plug it in again.• Ensure that there is power being supplied to the electrical outlet.• Ensure that the power is turned on. |
| No dial tone. | <ul style="list-style-type: none">• Check that the phone line is properly connected (see "Rear view" on page 23).• Check that the phone socket on the wall is working by plugging in another phone. |
| The numbers stored in memory do not dial correctly. | Make sure that the numbers are stored in memory correctly. To check that, print an address book list. |
| The original does not feed into the machine. | <ul style="list-style-type: none">• Make sure that the paper is not wrinkled and you are inserting it in correctly. Check that the original is the right size, not too thick or thin.• Make sure that the document feeder is firmly closed.• The document feeder rubber pad may need to be replaced. Contact a service representative (see "Available maintenance parts" on page 83). |
| Faxes are not received automatically. | <ul style="list-style-type: none">• The receiving mode should be set to fax (see "Changing the receive modes" on page 253).• Make sure that there is paper in the tray (see "Print media specifications" on page 127).• Check to see if the display shows any error message. If it does, clear the problem. |
| The machine does not send. | <ul style="list-style-type: none">• Make sure that the original is loaded in the document feeder or on the scanner glass.• Check the fax machine you are sending to, to see if it can receive your fax. |
| The incoming fax has blank spaces or is of poor-quality. | <ul style="list-style-type: none">• The fax machine sending you the fax may be faulty.• A noisy phone line can cause line errors.• Check your machine by making a copy.• A toner cartridge has almost reached its estimated cartridge life. Replace the toner cartridge (see "Replacing the toner cartridge" on page 87). |

Faxing problems

| Condition | Suggested solutions |
|--|---|
| Some of the words on an incoming fax are stretched. | The fax machine sending the fax had a temporary document jam. |
| There are lines on the originals you sent. | Check your scan unit for marks and clean it (see "Cleaning the scan unit" on page 98). |
| The machine dials a number, but the connection with the other fax machine fails. | The other fax machine may be turned off, out of paper, or cannot answer incoming calls. Speak with the other machine operator and ask them to solve the problem on their side. |
| Faxes do not store in memory. | There may not be enough memory space to store the fax. If the display indicating the memory status shows, delete any faxes you no longer need from the memory, and then try to store the fax again. Call for service. |
| Blank areas appear at the bottom of each page or on other pages, with a small strip of text at the top. | You may have chosen the wrong paper settings in the user option setting. Check the paper size and type again. |

Operating system problems

Common Windows problems

| Condition | Suggested solutions |
|--|--|
| “File in Use” message appears during installation. | Exit all software applications. Remove all software from the startup group, then restart Windows. Reinstall the printer driver. |
| “General Protection Fault”, “Exception OE”, “Spool 32”, or “Illegal Operation” messages appear. | Close all other applications, reboot Windows and try printing again. |
| “Fail To Print”, “A printer timeout error occurred” message appear. | These messages may appear during printing. Just keep waiting until the machine finishes printing. If the message appears in ready mode or after printing has completed, check the connection and/or whether an error has occurred. |
| Samsung Printer Experience is not shown when you click more settings . | Samsung Printer Experience is not installed. Download the app. from the Windows Store and install it. |
| Machine information is not displayed when you click the device in the Devices and Printers . | Check the Printer properties . Click the Ports tab. (Control Panel > Devices and Printers > Right-click on your printer icon and select Printer properties) If the port is set to File or LPT, uncheck them and select TCP/IP, USB, or WSD. |



Refer to the Microsoft Windows User’s Guide that came with your computer for further information on Windows error messages.

Operating system problems

Common Mac problems

| Condition | Suggested solutions |
|--|--|
| The machine does not print PDF files correctly. Some parts of graphics, text, or illustrations are missing. | <p>Printing the PDF file as an image may enable the file to print. Turn on Print As Image from the Acrobat printing options.</p> <p> It will take longer to print when you print a PDF file as an image.</p> |
| Some letters are not displayed normally during cover page printing. | <p>Mac OS cannot create the font while printing the cover page. The English alphabet and numbers are displayed normally on the cover page.</p> |
| When printing a document in Mac with Acrobat Reader 6.0 or higher, colors print incorrectly. | <p>Make sure that the resolution setting in your machine driver matches the one in Acrobat Reader.</p> |



Refer to the Mac User's Guide that came with your computer for further information on Mac error messages.

Operating system problems

Common Linux problems

| Condition | Suggested solutions |
|---|--|
| There is no xsane nor simple-scan application on my Linux machine. | For some Linux distributions, there might be no default scan application. To use scan features, install one of scan applications using download center supplied by the OS(ex. Ubuntu Software Center for Ubuntu, Install/Remove Software for openSUSE, Software for Fedora). |
| Scanner can not be found via network. | For some Linux distributions, strong firewall is enabled and it may block our installer from opening the necessary port for searching network devices. In such a case, open the snmp port - 22161 manually or disable the firewall temporarily while using the device. |
| When printing more than one copy, the second copy does not print. | The problem occurs on Ubuntu 12.04 due to the problem in standard CUPS filter 'pdftops'. Update 'cups-filters' package to version 1.0.18 to fix the problem ('pdftops' is a part of 'cups-filters' package). |
| Unchecking the collate option in the Print Dialog does not work. | For some distributions, GNOME Print Dialog has an issue handling the collate option. As workaround, set the default value of collate option to False using the system's printing utility(execute "system-config-printer" in the Terminal program). |
| Printing always works with duplex. | This duplex issue was in Ubuntu 9.10 CUPS package. Update CUPS version to 1.4.1-5ubuntu2.2. |
| Printer is not added through system's printing utility. | The problem occurs on Debian 7 due to the defect in 'system-config-printer' package of the Debian 7 (http://bugs.debian.org/cgi-bin/bugreport.cgi?bug=662813 in Debian bug tracking system). Please use another way to add printer (CUPS WebUI for example) |
| Paper size and orientation are disabled in the Print Dialog when opening text files. | The problem occurs on Fedora 19 and it's related to 'leafpad' text editor on Fedora 19. Please use other text editors like 'gedit'. |
| Printing produces divided images. | This issue exists in openSUSE 13.2 due to wrong ghostscript provided by the system. Update 'cups-filters-ghostscript' package with the command "zypper install --force cups-filters-ghostscript" or with "Install/Remove Software" utility. |

Operating system problems



Refer to the Linux User's Guide that came with your computer for further information on Linux error messages.

Common PostScript problems

The following situations are PS language specific and may occur when several printer languages are used.

| Problem | Possible cause | Solution |
|--|---|--|
| The PostScript file cannot be printed | The PostScript driver may not be installed correctly. | <ul style="list-style-type: none">• Install the PostScript driver (see "Software Installation" on page 150).• Print a configuration page and verify that the PS version is available for printing.• If the problem persists, contact a service representative. |
| Limit Check Error report prints | The print job was too complex. | You might need to reduce the complexity of the page or install more memory. |
| A PostScript error page prints | The print job may not be PostScript. | Make sure that the print job is a PostScript job. Check to see whether the software application expected a setup or PostScript header file to be sent to the machine. |
| The optional tray is not selected in the driver | The printer driver has not been configured to recognize the optional tray. | Open the driver properties, select the Device Options tab, and set the tray option. |
| When printing a document in Mac with Acrobat Reader 6.0 or higher, colors print incorrectly | The resolution setting in the printer driver may not be matched with the one in Acrobat Reader. | Make sure that the resolution setting in your printer driver matches the one in Acrobat Reader. |



The following glossary helps you get familiar with the product by understanding the terminologies commonly used with printing as well as mentioned in this user's guide.

802.11

802.11 is a set of standards for wireless local area network (WLAN) communication, developed by the IEEE LAN/MAN Standards Committee (IEEE 802).

802.11b/g/n

802.11b/g/n can share same hardware and use the 2.4 GHz band. 802.11b supports bandwidth up to 11 Mbps, 802.11n supports bandwidth up to 150 Mbps. 802.11b/g/n devices may occasionally suffer interference from microwave ovens, cordless telephones, and Bluetooth devices.

Access point

Access Point or Wireless Access Point (AP or WAP) is a device that connects wireless communication devices together on wireless local area networks (WLAN), and acts as a central transmitter and receiver of WLAN radio signals.

ADF

An Automatic Document Feeder (ADF) is a scanning unit that will automatically feed an original sheet of paper so that the machine can scan some amount of the paper at once.

AppleTalk

AppleTalk is a proprietary suite of protocols developed by Apple, Inc for computer networking. It was included in the original Mac (1984) and is now deprecated by Apple in favor of TCP/IP networking.

BIT Depth

A computer graphics term describing the number of bits used to represent the color of a single pixel in a bitmapped image. Higher color depth gives a broader range of distinct colors. As the number of bits increases, the number of possible colors becomes impractically large for a color map. 1-bit color is commonly called as monochrome or black and white.

BMP

A bitmapped graphics format used internally by the Microsoft Windows graphics subsystem (GDI), and used commonly as a simple graphics file format on that platform.

BOOTP

Bootstrap Protocol. A network protocol used by a network client to obtain its IP address automatically. This is usually done in the bootstrap process of computers or operating systems running on them. The BOOTP servers assign the IP address from a pool of addresses to each client. BOOTP enables 'diskless workstation' computers to obtain an IP address prior to loading any advanced operating system.

CCD

Charge Coupled Device (CCD) is a hardware which enables the scan job. CCD Locking mechanism is also used to hold the CCD module to prevent any damage when you move the machine.

Collation

Collation is a process of printing a multiple-copy job in sets. When collation is selected, the device prints an entire set before printing additional copies.

Control Panel

A control panel is a flat, typically vertical, area where control or monitoring instruments are displayed. They are typically found in front of the machine.

Coverage

It is the printing term used for a toner usage measurement on printing. For example, 5% coverage means that an A4 sided paper has about 5% image or text on it. So, if the paper or original has complicated images or lots of text on it, the coverage will be higher and at the same time, a toner usage will be as much as the coverage.

CSV

Comma Separated Values (CSV). A type of file format, CSV is used to exchange data between disparate applications. The file format, as it is used in Microsoft Excel, has become a de facto standard throughout the industry, even among non-Microsoft platforms.

DADF

A Duplex Automatic Document Feeder (DADF) is a scanning unit that will automatically feed and turn over an original sheet of paper so that the machine can scan on both sides of the paper.

Default

The value or setting that is in effect when taking a printer out of its box state, reset, or initialized.

DHCP

A Dynamic Host Configuration Protocol (DHCP) is a client-server networking protocol. A DHCP server provides configuration parameters specific to the DHCP client host requesting, generally, information required by the client host to participate on an IP network. DHCP also provides a mechanism for allocation of IP addresses to client hosts.

DIMM

Dual Inline Memory Module (DIMM), a small circuit board that holds memory. DIMM stores all the data within the machine like printing data, received fax data.

DLNA

The Digital Living Network Alliance (DLNA) is a standard that allows devices on a home network to share information with each other across the network.

DNS

The Domain Name Server (DNS) is a system that stores information associated with domain names in a distributed database on networks, such as the Internet.

Dot Matrix Printer

A dot matrix printer refers to a type of computer printer with a print head that runs back and forth on the page and prints by impact, striking an ink-soaked cloth ribbon against the paper, much like a typewriter.

DPI

Dots Per Inch (DPI) is a measurement of resolution that is used for scanning and printing. Generally, higher DPI results in a higher resolution, more visible detail in the image, and a larger file size.

DRPD

Distinctive Ring Pattern Detection. Distinctive Ring is a telephone company service which enables a user to use a single telephone line to answer several different telephone numbers.

Duplex

A mechanism that will automatically turn over a sheet of paper so that the machine can print (or scan) on both sides of the paper. A printer equipped with a Duplex Unit can print on both sides of paper during one print cycle.

Duty Cycle

Duty cycle is the page quantity which does not affect printer performance for a month. Generally the printer has the lifespan limitation such as pages per year. The lifespan means the average capacity of print-outs, usually within the warranty period. For example, if the duty cycle is 48,000 pages per month assuming 20 working days, a printer limits 2,400 pages a day.

ECM

Error Correction Mode (ECM) is an optional transmission mode built into Class 1 fax machines or fax modems. It automatically detects and corrects errors in the fax transmission process that are sometimes caused by telephone line noise.

Emulation

Emulation is a technique of one machine obtaining the same results as another.

An emulator duplicates the functions of one system with a different system, so that the second system behaves like the first system. Emulation focuses on exact reproduction of external behavior, which is in contrast to simulation, which concerns an abstract model of the system being simulated, often considering its internal state.

Ethernet

Ethernet is a frame-based computer networking technology for local area networks (LANs). It defines wiring and signaling for the physical layer, and frame formats and protocols for the media access control (MAC)/data link layer of the OSI model. Ethernet is mostly standardized as IEEE 802.3. It has become the most widespread LAN technology in use during the 1990s to the present.

EtherTalk

A suite of protocols developed by Apple Computer for computer networking. It was included in the original Mac (1984) and is now deprecated by Apple in favor of TCP/IP networking.

FDI

Foreign Device Interface (FDI) is a card installed inside the machine to allow a third party device such as a coin operated device or a card reader. Those devices allow the pay-for-print service on your machine.

FTP

A File Transfer Protocol (FTP) is a commonly used protocol for exchanging files over any network that supports the TCP/IP protocol (such as the Internet or an intranet).

Fuser Unit

The part of a laser printer that fuses the toner onto the print media. It consists of a heat roller and a pressure roller. After toner is transferred onto the paper, the fuser unit applies heat and pressure to ensure that the toner stays on the paper permanently, which is why paper is warm when it comes out of a laser printer.

Gateway

A connection between computer networks, or between a computer network and a telephone line. It is very popular, as it is a computer or a network that allows access to another computer or network.

Grayscale

A shade of gray that represents light and dark portions of an image when color images are converted to grayscale; colors are represented by various shades of gray.

Halftone

An image type that simulates grayscale by varying the number of dots. Highly colored areas consist of a large number of dots, while lighter areas consist of a smaller number of dots.

Mass storage device (HDD)

Mass storage device (HDD), commonly referred to as a hard drive or hard disk, is a non-volatile storage device which stores digitally-encoded data on rapidly rotating platters with magnetic surfaces.

IEEE

The Institute of Electrical and Electronics Engineers (IEEE) is an international non-profit, professional organization for the advancement of technology related to electricity.

IEEE 1284

The 1284 parallel port standard was developed by the Institute of Electrical and Electronics Engineers (IEEE). The term "1284-B" refers to a specific connector type on the end of the parallel cable that attaches to the peripheral (for example, a printer).

Intranet

A private network that uses Internet Protocols, network connectivity, and possibly the public telecommunication system to securely share part of an organization's information or operations with its employees. Sometimes the term refers only to the most visible service, the internal website.

IP address

An Internet Protocol (IP) address is a unique number that devices use in order to identify and communicate with each other on a network utilizing the Internet Protocol standard.

IPM

The Images Per Minute (IPM) is a way of measuring the speed of a printer. An IPM rate indicates the number of single-sided sheets a printer can complete within one minute.

IPP

The Internet Printing Protocol (IPP) defines a standard protocol for printing as well as managing print jobs, media size, resolution, and so forth. IPP can be used locally or over the Internet to hundreds of printers, and also supports access control, authentication, and encryption, making it a much more capable and secure printing solution than older ones.

IPX/SPX

IPX/SPX stands for Internet Packet Exchange/Sequenced Packet Exchange. It is a networking protocol used by the Novell NetWare operating systems. IPX and SPX both provide connection services similar to TCP/IP, with the IPX protocol having similarities to IP, and SPX having similarities to TCP. IPX/SPX was primarily designed for local area networks (LANs), and is a very efficient protocol for this purpose (typically its performance exceeds that of TCP/IP on a LAN).

ISO

The International Organization for Standardization (ISO) is an international standard-setting body composed of representatives from national standards bodies. It produces world-wide industrial and commercial standards.

ITU-T

The International Telecommunication Union is an international organization established to standardize and regulate international radio and telecommunications. Its main tasks include standardization, allocation of the radio spectrum, and organizing interconnection arrangements between different countries to allow international phone calls. A -T out of ITU-T indicates telecommunication.

ITU-T No. 1 chart

Standardized test chart published by ITU-T for document facsimile transmissions.

JBIG

Joint Bi-level Image Experts Group (JBIG) is an image compression standard with no loss of accuracy or quality, which was designed for compression of binary images, particularly for faxes, but can also be used on other images.

JPEG

Joint Photographic Experts Group (JPEG) is a most commonly used standard method of lossy compression for photographic images. It is the format used for storing and transmitting photographs on the World Wide Web.

LDAP

The Lightweight Directory Access Protocol (LDAP) is a networking protocol for querying and modifying directory services running over TCP/IP.

LED

A Light-Emitting Diode (LED) is a semiconductor device that indicates the status of a machine.

MAC address

Media Access Control (MAC) address is a unique identifier associated with a network adapter. MAC address is a unique 48-bit identifier usually written as 12 hexadecimal characters grouped in pairs (e. g., 00-00-0c-34-11-4e). This address is usually hard-coded into a Network Interface Card (NIC) by its manufacturer, and used as an aid for routers trying to locate machines on large networks.

MFP

Multi Function Peripheral (MFP) is an office machine that includes the following functionality in one physical body, so as to have a printer, a copier, a fax, a scanner and etc.

MH

Modified Huffman (MH) is a compression method for decreasing the amount of data that needs to be transmitted between the fax machines to transfer the image recommended by ITU-T T.4. MH is a codebook-based run-length encoding scheme optimized to efficiently compress white space. As most faxes consist mostly of white space, this minimizes the transmission time of most faxes.

MMR

Modified Modified READ (MMR) is a compression method recommended by ITU-T T.6.

Modem

A device that modulates a carrier signal to encode digital information, and also demodulates such a carrier signal to decode transmitted information.

MR

Modified Read (MR) is a compression method recommended by ITU-T T.4. MR encodes the first scanned line using MH. The next line is compared to the first, the differences determined, and then the differences are encoded and transmitted.

NetWare

A network operating system developed by Novell, Inc. It initially used cooperative multitasking to run various services on a PC, and the network protocols were based on the archetypal Xerox XNS stack. Today NetWare supports TCP/IP as well as IPX/SPX.

OPC

Organic Photo Conductor (OPC) is a mechanism that makes a virtual image for print using a laser beam emitted from a laser printer, and it is usually green or rust colored and has a cylinder shape.

An imaging unit containing a drum slowly wears the drum surface by its usage in the printer, and it should be replaced appropriately since it gets worn from contact with the cartridge development brush, cleaning mechanism, and paper.

Originals

The first example of something, such as a document, photograph or text, etc, which is copied, reproduced or translated to produce others, but which is not itself copied or derived from something else.

OSI

Open Systems Interconnection (OSI) is a model developed by the International Organization for Standardization (ISO) for communications. OSI offers a standard, modular approach to network design that divides the required set of complex functions into manageable, self-contained, functional layers. The layers are, from top to bottom, Application, Presentation, Session, Transport, Network, Data Link and Physical.

PABX

A private automatic branch exchange (PABX) is an automatic telephone switching system within a private enterprise.

PCL

Printer Command Language (PCL) is a Page Description Language (PDL) developed by HP as a printer protocol and has become an industry standard. Originally developed for early inkjet printers, PCL has been released in varying levels for thermal, dot matrix printer, and laser printers.

PDF

Portable Document Format (PDF) is a proprietary file format developed by Adobe Systems for representing two dimensional documents in a device independent and resolution independent format.

PostScript

PostScript (PS) is a page description language and programming language used primarily in the electronic and desktop publishing areas. - that is run in an interpreter to generate an image.

Printer Driver

A program used to send commands and transfer data from the computer to the printer.

Print Media

The media like paper, labels, and transparencies which can be used in a printer, a scanner, a fax or, a copier.

PPM

Pages Per Minute (PPM) is a method of measurement for determining how fast a printer works, meaning the number of pages a printer can produce in one minute.

PRN file

An interface for a device driver, this allows software to interact with the device driver using standard input/output system calls, which simplifies many tasks.

Protocol

A convention or standard that controls or enables the connection, communication, and data transfer between two computing endpoints.

PS

See PostScript.

PSTN

The Public-Switched Telephone Network (PSTN) is the network of the world's public circuit-switched telephone networks which, on industrial premises, is usually routed through the switchboard.

RADIUS

Remote Authentication Dial In User Service (RADIUS) is a protocol for remote user authentication and accounting. RADIUS enables centralized management of authentication data such as usernames and passwords using an AAA (authentication, authorization, and accounting) concept to manage network access.

Resolution

The sharpness of an image, measured in Dots Per Inch (DPI). The higher the dpi, the greater the resolution.

SMB

Server Message Block (SMB) is a network protocol mainly applied to share files, printers, serial ports, and miscellaneous communications between nodes on a network. It also provides an authenticated Inter-process communication mechanism.

SMTP

Simple Mail Transfer Protocol (SMTP) is the standard for e-mail transmissions across the Internet. SMTP is a relatively simple, text-based protocol, where one or more recipients of a message are specified, and then the message text is transferred. It is a client-server protocol, where the client transmits an email message to the server.

SSID

Service Set Identifier (SSID) is a name of a wireless local area network (WLAN). All wireless devices in a WLAN use the same SSID in order to communicate with each other. The SSIDs are case-sensitive and have a maximum length of 32 characters.

Subnet Mask

The subnet mask is used in conjunction with the network address to determine which part of the address is the network address and which part is the host address.

TCP/IP

The Transmission Control Protocol (TCP) and the Internet Protocol (IP); the set of communications protocols that implement the protocol stack on which the Internet and most commercial networks run.

TCR

Transmission Confirmation Report (TCR) provides details of each transmission such as job status, transmission result and number of pages sent. This report can be set to print after each job or only after failed transmissions.

TIFF

Tagged Image File Format (TIFF) is a variable-resolution bitmapped image format. TIFF describes image data that typically come from scanners. TIFF images make use of tags, keywords defining the characteristics of the image that is included in the file. This flexible and platform-independent format can be used for pictures that have been made by various image processing applications.

Toner Cartridge

A kind of bottle or container used in a machine like a printer which contains toner. Toner is a powder used in laser printers and photocopiers, which forms the text and images on the printed paper. Toner can be fused by a combination of heat/pressure from the fuser, causing it to bind to the fibers in the paper.

TWAIN

An industry standard for scanners and software. By using a TWAIN-compliant scanner with a TWAIN-compliant program, a scan can be initiated from within the program. It is an image capture API for Microsoft Windows and Apple Mac operating systems.

UNC Path

Uniform Naming Convention (UNC) is a standard way to access network shares in Window NT and other Microsoft products. The format of a UNC path is:
\\<servername>\<sharename>\<Additional directory>

URL

Uniform Resource Locator (URL) is the global address of documents and resources on the Internet. The first part of the address indicates what protocol to use, the second part specifies the IP address or the domain name where the resource is located.

USB

Universal Serial Bus (USB) is a standard that was developed by the USB Implementers Forum, Inc., to connect computers and peripherals. Unlike the parallel port, USB is designed to concurrently connect a single computer USB port to multiple peripherals.

Watermark

A watermark is a recognizable image or pattern in paper that appears lighter when viewed by transmitted light. Watermarks were first introduced in Bologna, Italy in 1282; they have been used by papermakers to identify their product, and also on postage stamps, currency, and other government documents to discourage counterfeiting.

WEP

Wired Equivalent Privacy (WEP) is a security protocol specified in IEEE 802.11 to provide the same level of security as that of a wired LAN. WEP provides security by encrypting data over radio so that it is protected as it is transmitted from one end point to another.

WIA

Windows Imaging Architecture (WIA) is an imaging architecture that is originally introduced in Windows Me and Windows XP Service Pack 3. A scan can be initiated from within these operating systems by using a WIA-compliant scanner.

WPA

Wi-Fi Protected Access (WPA) is a class of systems to secure wireless (Wi-Fi) computer networks, which was created to improve upon the security features of WEP.

WPA-PSK

WPA-PSK (WPA Pre-Shared Key) is special mode of WPA for small business or home users. A shared key, or password, is configured in the wireless access point (WAP) and any wireless laptop or desktop devices. WPA-PSK generates a unique key for each session between a wireless client and the associated WAP for more advanced security.

WPS

The Wi-Fi Protected Setup (WPS) is a standard for establishing a wireless home network. If your wireless access point supports WPS, you can configure the wireless network connection easily without a computer.

XPS

XML Paper Specification (XPS) is a specification for a Page Description Language (PDL) and a new document format, which has benefits for portable document and electronic document, developed by Microsoft. It is an XML-based specification, based on a new print path and a vector-based device-independent document format.

Contact SAMSUNG worldwide

| Country/Region | Customer Care Center | WebSite |
|-----------------------|--|--|
| CAMEROON | 7095- 0077 | www.samsung.com/africa_fr/support |
| CANADA | 1-800-SAMSUNG (726-7864) | www.samsung.com/ca/support(English) www.samsung.com/ca_fr/support (French) |
| CHILE | 800-SAMSUNG (726-7864) [HHP] 02-24828200 | www.samsung.com/cl/support |
| CHINA | 400-810-5858 | www.samsung.com/cn/support |
| COLOMBIA | Bogotá en el 600 12 72Sin costo en todo el país 01 8000 112 112Y desde tu celular #726 | www.samsung.com/co |
| COSTA RICA | 00-800-1-SAMSUNG (726-7864) | www.samsung.com/latin/support (Spanish) www.samsung.com/latin_en/support (English) |
| CROATIA | 072 726 786 | www.samsung.com/hr/support |
| Cote D' Ivoire | 8000 0077 | www.samsung.com/africa_fr/support |

| Country/Region | Customer Care Center | WebSite |
|---------------------------|---|--|
| CYPRUS | 8009 4000 only from landline, toll free | www.samsung.com/gr/support |
| CZECH | 800-SAMSUNG (800-726786) | www.samsung.com/cz/support |
| DENMARK | 70 70 19 70 | www.samsung.com/dk/support |
| DOMINICAN REPUBLIC | 1-800-751-2676 | www.samsung.com/latin/support (Spanish) www.samsung.com/latin_en/support (English) |
| DRC | 499999 | www.samsung.com/support |
| ECUADOR | 1-800-SAMSUNG (72-6786) | www.samsung.com/latin/support (Spanish) www.samsung.com/latin_en/support (English) |
| EGYPT | 08000-7267864 16580 | www.samsung.com/eg/support |

Contact SAMSUNG worldwide

| Country/Region | Customer Care Center | WebSite |
|--------------------|---|--|
| EIRE | 0818 717100 | www.samsung.com/ie/support |
| EL SALVADOR | 8000-SAMSUNG (726-7864) | www.samsung.com/latin/support (Spanish) www.samsung.com/latin_en/support (English) |
| ESTONIA | 800-7267 | www.samsung.com/ee/support |
| FINLAND | 030-6227 515 | www.samsung.com/fi/support |
| FRANCE | 01 48 63 00 00 | www.samsung.com/fr/support |
| GERMANY | 0180 6 SAMSUNG bzw. 0180 6 7267864* (*0,20 €/Anruf aus dem dt. Festnetz, aus dem Mobilfunk max. 0,60 €/Anruf) [HHP] 0180 6 M SAMSUNG bzw. 0180 6 67267864* (*0,20 €/Anruf aus dem dt. Festnetz, aus dem Mobilfunk max. 0,60 €/Anruf) | www.samsung.com/de/support |

| Country/Region | Customer Care Center | WebSite |
|------------------|---|--|
| GEORGIA | 0-800-555-555 | www.samsung.com/support |
| GHANA | 0800-10077 0302-200077 | www.samsung.com/africa_en/support |
| GREECE | 80111-SAMSUNG (80111 726 7864) only from land line (+30) 210 6897691 from mobile and land line | www.samsung.com/gr/support |
| GUATEMALA | 1-800-299-0033 | www.samsung.com/latin/support (Spanish) www.samsung.com/latin_en/support (English) |
| HONDURAS | 800-2791-9111 | www.samsung.com/latin/support (Spanish) www.samsung.com/latin_en/support (English) |

Contact SAMSUNG worldwide

| Country/Region | Customer Care Center | WebSite |
|------------------|--|--|
| HONG KONG | 3698 4698 | www.samsung.com/ hk/support (Chinese) www.samsung.com/ hk_en/support (English) |
| HUNGARY | 0680SAMSUNG (0680-726-786)0680PREMIUM (0680-773-648) | www.samsung.com/ hu/support |
| INDIA | 1800 3000 8282 - Toll Free1800 266 8282 - Toll Free | www.samsung.com/ in/support |
| INDONESIA | 021-56997777 08001128888 | www.samsung.com/ id/support |
| IRAN | 021-8255 [CE] 021-42132 [HHP] | www.samsung.com/ iran/support |
| ITALIA | 800-SAMSUNG (800.7267864) | www.samsung.com/ it/support |
| JAMAICA | 1-800-SAMSUNG (726-7864) | www.samsung.com/ latin_en/support (English) |
| JAPAN | 0120-363-905 | www.samsung.com/ jp/support |

| Country/Region | Customer Care Center | WebSite |
|-------------------|---|--|
| JORDAN | 0800-22273 06 5777444 | www.samsung.com/ Levant |
| KAZAKHSTAN | 8-10-800-500-55-500 (GSM: 7799, VIP care 7700) | www.samsung.com/ kz_ru/support |
| KENYA | 0800 545 545 | www.samsung.com/ support |
| KUWAIT | 183-CALL (183-2255) | www.samsung.com/ ae/support (English) www.samsung.com/ ae_ar/support (Arabic) |
| KYRGYZSTAN | 00-800-500-55-500 (GSM: 9977) | www.samsung.com/ support |
| LATVIA | 8000-7267 | www.samsung.com/ lv/support |
| LEBANON | 961 1484 999 | www.samsung.com/ Levant |
| LITHUANIA | 8-800-77777 | www.samsung.com/ lt/support |
| LUXEMBURG | 261 03 710 | www.samsung.com/ be_fr/support |
| MACAU | 0800 333 | www.samsung.com/ support |

Contact SAMSUNG worldwide

| Country/Region | Customer Care Center | WebSite |
|-------------------|---|----------------------------------|
| MACEDONIA | 023 207 777 | |
| MALAYSIA | 1800-88-9999 603-77137477 (Overseas contact) | www.samsung.com/my/support |
| MAURITIUS | 800 2550 | www.samsung.com/support |
| MEXICO | 01-800-SAMSUNG (726-7864) | www.samsung.com/mx/support |
| MOLDOVA | 0-800-614-40 | www.samsung.com/support |
| MONGOLIA | +7-495-363-17-00 | www.samsung.com/support |
| MONTENEGRO | 020 405 888 | www.samsung.com/support |
| MOROCCO | 080 100 22 55 | www.samsung.com/n_africa/support |
| MOZAMBIQUE | 847267864 / 827267864 | www.samsung.com/support |
| MYANMAR | +95-01-2399-888 | www.samsung.com/support |
| NAMIBIA | 08 197 267 864 | www.samsung.com/support |

| Country/Region | Customer Care Center | WebSite |
|--------------------|---|--|
| NIGERIA | 0800-726-7864 | www.samsung.com/africa_en/support |
| NETHERLANDS | 0900-SAMSUNG (0900-7267864) (€ 0,10/Min) | www.samsung.com/nl/support |
| NEW ZEALAND | 0800 726 786 | www.samsung.com/nz/support |
| NICARAGUA | 001-800-5077267 | www.samsung.com/latin/support(Spanish) www.samsung.com/latin_en/support (English) |
| NORWAY | 815 56480 | www.samsung.com/no/support |
| OMAN | 800-SAMSUNG (800 - 726 7864) | www.samsung.com/ae/support (English) www.samsung.com/ae_ar/support (Arabic) |
| PAKISTAN | 0800-Samsung (72678) | www.samsung.com/pk/support |

Contact SAMSUNG worldwide

| Country/Region | Customer Care Center | WebSite |
|--------------------|---|---|
| PANAMA | 800-0101 | www.samsung.com/ latin/support (Spanish) www.samsung.com/ latin_en/support (English) |
| PARAGUAY | 0800-11-SAMS(7267) | www.samsung.com/ar |
| PERU | 0800-777-08 | www.samsung.com/ pe/support |
| PHILIPPINES | 1-800-10-726-7864 [PLDT Toll Free] 1-800-8-726-7864 [Globe Landline and Mobile] 02- 422-2111 [Standard Landline] | www.samsung.com/ ph/support |
| POLAND | 801-172-678* lub +48 22 607-93-33* Dedykowana infolinia do obsługi zapytań dotyczących telefonów komórkowych: 801-672-678* lub +48 22 607-93-33* * (koszt połączenia według taryfy operatora) | www.samsung.com/ pl/support |

| Country/Region | Customer Care Center | WebSite |
|--------------------|---|---|
| PORTUGAL | 808 20 7267 | www.samsung.com/ pt/support |
| PUERTO RICO | 1-800-682-3180 | www.samsung.com/ latin/support (Spanish) www.samsung.com/ latin_en/support (English) |
| QATAR | 800-CALL (800-2255) | www.samsung.com/ ae/support (English) www.samsung.com/ ae_ar/support (Arabic) |
| REUNION | 0262 50 88 80 | www.samsung.com/ support |
| RWANDA | 9999 | www.samsung.com/ support |
| ROMANIA | *8000 (apel in retea) 08008-726-78-64 (08008-SAMSUNG) Apel GRATUIT | www.samsung.com/ ro/support |
| RUSSIA | 8-800-555-55-55 (VIP care 8-800-555-55-88) | www.samsung.com/ ru/support |

Contact SAMSUNG worldwide

| Country/Region | Customer Care Center | WebSite |
|---------------------|-------------------------------------|--|
| SAUDI ARABIA | 800 247 3457 (800 24/7 HELP) | www.samsung.com/ sa/home www.samsung.com/ sa_en |
| SENEGAL | 800-00-0077 | www.samsung.com/ africa_fr/support |
| SERBIA | 011 321 6899 | www.samsung.com/ rs/support |
| SINGAPORE | 1800-SAMSUNG (726-7864) | www.samsung.com/ sg/support |
| SLOVENIA | 080 697 267 (brezplačna številka) | www.samsung.com/si |
| SLOVAKIA | 0800 - SAMSUNG (0800-726 786) | www.samsung.com/ sk/support |
| SOUTH AFRICA | 0860 SAMSUNG (726 7864) | www.samsung.com/ support |
| SPAIN | 0034902172678[HHP] 0034902167267 | www.samsung.com/ es/support |
| SRI LANKA | 0117540540 0115900000 | www.samsung.com/ support |
| SUDAN | 1969 | www.samsung.com/ support |

| Country/Region | Customer Care Center | WebSite |
|----------------------------------|-------------------------------|---|
| SWEDEN | 0771 726 7864 (0771-SAMSUNG) | www.samsung.com/ se/support |
| SWITZERLAND | 0800 726 78 64 (0800-SAMSUNG) | www.samsung.com/ ch/support (German) www.samsung.com/ ch_fr/support (French) |
| SYRIA | 18252273 | www.samsung.com/ Levant |
| TAJIKISTAN | 8-10-800-500-55-500 | www.samsung.com/ support |
| TAIWAN | 0800-329999 | www.samsung.com/ tw/support |
| TANZANIA | 0800 755 755 0685 889 900 | www.samsung.com/ support |
| THAILAND | 0-2689-3232, 1800-29-3232 | www.samsung.com/ th/support |
| TRINIDAD & TOBAGO | 1-800-SAMSUNG (726-7864) | www.samsung.com/ latin/support (Spanish) www.samsung.com/ latin_en/support (English) |

Contact SAMSUNG worldwide

| Country/Region | Customer Care Center | WebSite |
|--|-----------------------------|--|
| TURKEY | 444 77 11 | www.samsung.com/tr/support |
| TUNISIA | 80-1000-12 | www.samsung.com/n_africa/support |
| U.A.E | 800-SAMSUNG (800 -726 7864) | www.samsung.com/ae/support (English) www.samsung.com/ae_ar/support (Arabic) |
| UK | 0330 SAMSUNG (7267864) | www.samsung.com/uk/support |
| U.S.A -Consumer Electronics | 1-800-SAMSUNG (726-7864) | www.samsung.com/us/support |
| U.S.A -(Mobile Phones) | 1-800-SAMSUNG (726-7864) | www.samsung.com/us/support |
| UGANDA | 0800 300 300 | www.samsung.com/support |
| UKRAINE | 0-800-502-000 | www.samsung.com/ua/support (Ukrainian) www.samsung.com/ua_ru/support (Russian) |

| Country/Region | Customer Care Center | WebSite |
|-------------------|-------------------------------|--|
| URUGUAY | 0800-SAMS(7267) | www.samsung.com/ar |
| UZBEKISTAN | 00-800-500-55-500 (GSM: 7799) | www.samsung.com/support |
| VENEZUELA | 0-800-SAMSUNG (726-7864) | www.samsung.com/ve/support |
| VIETNAM | 1800 588 889 | www.samsung.com/vn/support |
| ZAMBIA | 0211 350370 | www.samsung.com/support |

Index

A

address book

- editing 228
- group editing 229
- group registering 229
- registering 228
- using 228

address book setup 228

AirPrint 196

B

buttons

- eco 25, 27
- id copy 26
- numeric keypad 27
- scan to 24
- wps 24, 26

C

cleaning

- inside 101
- outside 100
- scan unit 104

cleaning a machine 100

control panel 24

convention 13

copy

general setup 207

copying

- basic copying 65
- reducing or enlarging copies 66

D

default settings

tray setting 53

E

easy document creator 246, 272

e-book conversion 272

eco printing 63

entering character 226

error message 117

F

favorites settings, for printing 62

fax

automatic redialing 249

canceling a reserved fax job 251

changing the receive modes 253

delaying a fax transmission 251

forwarding a received fax to another destination 252

forwarding a sent fax to another destination 252

general setup 210

receiving a fax in the computer 253

receiving faxes in memory 256

receiving in Answering Machine mode 254

receiving in DRPD mode 255

receiving in Fax mode 254

receiving in secure mode 255

receiving in Tel mode 254

receiving with ext. telephone 254

redialing the last number 249

sending a fax in the computer 250

fax feature 249

fax sending

multi sending 72

faxing

adjusting darkness 74

adjusting resolution 73

preparing to fax 71

Index

| | |
|-----------------------|-----|
| receiving in Fax mode | 73 |
| features | 5 |
| machine features | 204 |
| print media feature | 127 |
| front view | 21 |

G

| | |
|-----------------------|-----|
| general icons | 13 |
| general settings | 216 |
| glossary | 305 |
| google cloud printing | 201 |

I

| | |
|---------|----|
| id copy | 67 |
|---------|----|

J

| | |
|------------------------------|-----|
| jam | |
| clearing original document | 108 |
| tips for avoiding paper jams | 107 |

L

| | |
|-----------------------------|-------------------------|
| LCD display | |
| browsing the machine status | 207, 208, 210, 215, 219 |

| | |
|-------------------------------------|-----|
| Linux | |
| common Linux problems | 303 |
| driver installation for network | |
| connected | 163 |
| driver installation for USB cable | |
| connected | 153 |
| driver reinstallation for USB cable | |
| connected | 154 |
| printer properties | 241 |
| printing | 240 |
| scanning | 248 |
| using SetIP | 158 |
| linux scanning | 248 |
| loading | |
| paper in the tray ¹ | 46 |
| special media | 50 |
| loading originals | 55 |

M

| | |
|-----------------------------------|-----|
| Mac | |
| common Mac problems | 302 |
| driver installation for network | |
| connected | 163 |
| driver installation for USB cable | |

| | |
|-------------------------------------|-------------------------|
| connected | 151 |
| driver reinstallation for USB cable | |
| connected | 152 |
| printing | 239 |
| system requirements | 131 |
| using SetIP | 158 |
| machine information | 207, 208, 210, 215, 219 |
| machine setup | |
| machine status | 207, 208, 210, 215, 219 |
| Macintosh | |
| scanning | 247 |
| maintenance parts | 84 |
| menu overview | 34 |
| Mopria | 194 |
| multi-purpose tray | |
| using special media | 50 |

N

| | |
|---------------------|-----|
| network | |
| driver installation | |
| Linux | 163 |
| Mac | 163 |
| Windows | 160 |
| general setup | 222 |

Index

| | | | | | |
|------------------------------|---------------|--------------------------------------|-----|---------------------------------|-----|
| installing environment | 132 | mobile OS | 186 | printing on both sides of paper | |
| introducing network programs | 156 | mobile print | 186 | Mac | 240 |
| IPv6 configuration | 165 | print media | | printing to a file | 232 |
| SetIP program | 157, 158, 178 | card stock | 52 | setting as a default machine | 231 |
| wired network setup | 157 | guidelines | 44 | special printer features | 233 |
| wireless network setup | 168 | labels | 52 | USB memory | 76 |
| n-up printing | | output support | 127 | printing a document | |
| Mac | 239 | preprinted paper | 53 | Linux | 240 |
| O | | setting the paper size | 53 | Mac | 239 |
| output support | 54 | setting the paper type | 53 | printing feature | 231 |
| overlay printing | | special media | 50 | problem | |
| create | 237 | print menu | 206 | operating system problems | 301 |
| delete | 238 | printer preferences | | problems | |
| print | 238 | Linux | 241 | copying problems | 297 |
| P | | printer status | | faxing problems | 299 |
| placing a machine | | general information | 273 | paper feeding problems | 283 |
| adjusting the altitude | 225 | printing | | power problems | 284 |
| postScript driver | | changing the default print settings | 231 | printing problems | 285 |
| troubleshooting | 304 | Linux | 240 | printing quality problems | 289 |
| preparing originals type | 55 | Mac | 239 | scanning problems | 298 |
| print | | multiple pages on one sheet of paper | | R | |
| general setup | 206 | Mac | 239 | rear view | 23 |
| | | printing a document | | regulatory information | 133 |
| | | Windows | 59 | | |

Index

| | | | |
|--------------------------------------|------------------------------------|------------------|----------|
| reports | | | |
| machine | | | |
| information | 207, 210, 211, 212, 216, 217, 219, | | 220 |
| resolution | | | |
| faxing | | 73 | |
| S | | | |
| safety | | | |
| information | | 14 | |
| symbols | | 14 | |
| samsung cloud printing | | 198 | |
| samsung printer experience | | 275 | |
| Samsung Printer Status | | 273 | |
| scan | | | |
| general setup | | 214 | |
| scan feature | | 242 | |
| Scanning | | | |
| Scanning with Samsung Scan Assistant | | 246 | |
| scanning | | | |
| basic information | | 242 | |
| Linux scanning | | 248 | |
| Macintosh | | 247 | |
| Scanning from image editing program | | 246 | |
| Scanning from network | | | |
| connected machine | 243, 245 | | |
| Scanning to email | | 244 | |
| Scanning using the WIA driver | | 247 | |
| USB flash memory | | 77 | |
| service contact numbers | | 317 | |
| SetIP program | | 157, 178 | |
| Special features | | 224 | |
| specifications | | 125 | |
| print media | | 127 | |
| status | | 25, 27 | |
| supplies | | | |
| available supplies | | 82 | |
| estimated toner cartridge life | | 86 | |
| monitoring the supplies life | | 98 | |
| ordering | | 82 | |
| replacing toner cartridge | | 90 | |
| SyncThru Web Service | | | |
| general information | | 266 | |
| SyncThru™ Web Service | | 266 | |
| T | | | |
| toner cartridge | | | |
| estimated life | | 86 | |
| handling instructions | | | 85 |
| non-Samsung and refilled | | | 85 |
| redistributing toner | | | 87 |
| replacing the cartridge | | | 90 |
| storing | | | 85 |
| tray | | | |
| adjusting the width and length | | | 45 |
| changing the tray size | | | 45 |
| setting the paper size and type | | | 53 |
| U | | | |
| understanding the status LED | | | 115 |
| Unix | | | |
| system requirements | | | 131 |
| USB cable | | | |
| driver installation | | 30, 32, 151, 153 | |
| driver reinstallation | | | 152, 154 |
| USB flash memory | | | |
| managing | | | 78 |
| printing | | | 76 |
| scanning | | | 77 |
| using help | | | 62, 240 |

W

watermark

| | |
|--------|-----|
| create | 236 |
| delete | 236 |
| edit | 236 |

Windows

| | |
|--|----------|
| common Windows problems | 301 |
| driver installation for network connected | 160 |
| driver installation for USB cable connected | 30, 32 |
| system requirements | 129 |
| using SetIP | 157, 178 |

wireless

| | |
|---------------|-----|
| USB cable | 174 |
| WPS | |
| disconnecting | 170 |

wireless network

| | |
|---------------|-----|
| network cable | 178 |
|---------------|-----|