

ML1100

**OKI**  
PRINTING SOLUTIONS



## User's Guide

ML1120/ML1190



# PREFACE

Every effort has been made to ensure that the information in this document is complete, accurate, and up-to-date. Oki Printing Solutions assumes no responsibility for the results of errors beyond its control. Oki Printing Solutions also cannot guarantee that changes in software and equipment made by other manufacturers and referred to in this guide will not affect the applicability of the information in it. Mention of software products manufactured by other companies does not necessarily constitute endorsement by Oki Printing Solutions.

While all reasonable efforts have been made to make this document as accurate and helpful as possible, we make no warranty of any kind, expressed or implied, as to the accuracy or completeness of the information contained herein.

The most up-to-date drivers and manuals are available from the Oki Printing Solutions web site:

**<http://www.okiprintingsolutions.com>**

Copyright © 2007 Oki Printing Solutions.

Oki, OKI Printing Solutions and Microline are registered trademarks of Oki Electric Industry Company, Ltd.

ENERGY STAR is a trademark of the United States Environmental Protection Agency.

Microsoft, MS-DOS and Windows are registered trademarks of Microsoft Corporation.

Other product names and brand names are registered trademarks or trademarks of their proprietors.



As an ENERGY STAR Program Participant, the manufacturer has determined that this product meets the ENERGY STAR guidelines for energy efficiency.



This product complies with the requirements of the Council Directives 89/336/EEC (EMC) and 73/23/EEC (LVD) as amended where applicable on the approximation of the laws of the member states relating to electromagnetic compatibility and low voltage.



# CONTENTS

|  |           |
|--|-----------|
| <b>Preface</b> .....                         | <b>2</b>  |
| <b>Notes, cautions and warnings.</b> .....   | <b>5</b>  |
| <b>Introduction</b> .....                    | <b>6</b>  |
| About this guide .....                       | 6         |
| On-line usage .....                          | 7         |
| Printing pages .....                         | 7         |
| <b>Getting started</b> .....                 | <b>9</b>  |
| Retaining packing materials .....            | 9         |
| Identifying component parts .....            | 9         |
| Front view .....                             | 9         |
| Rear view .....                              | 11        |
| Locating your printer .....                  | 12        |
| Powering on your printer .....               | 12        |
| Producing a test print .....                 | 13        |
| <b>Connecting to a computer</b> .....        | <b>15</b> |
| Interfaces .....                             | 15        |
| Interconnection .....                        | 15        |
| Installing the printer driver .....          | 16        |
| Printing a test page .....                   | 16        |
| <b>Printing from a computer</b> .....        | <b>17</b> |
| <b>Paper handling</b> .....                  | <b>18</b> |
| Loading cut sheet paper .....                | 18        |
| Ejecting cut sheet paper .....               | 20        |
| Loading continuous forms .....               | 21        |
| Setting up continuous forms .....            | 21        |
| Feeding continuous forms (rear feed) .....   | 21        |
| Feeding continuous forms (bottom feed) ..... | 25        |
| Tearing off continuous forms .....           | 35        |
| Aligning the tear-off perforations .....     | 35        |
| Removing continuous forms .....              | 36        |
| Setting the Paper Thickness lever .....      | 38        |
| <b>Operating instructions</b> .....          | <b>40</b> |
| Control panel .....                          | 40        |
| ML1120 .....                                 | 40        |
| ML1190 .....                                 | 42        |
| Buttons .....                                | 44        |
| Setting menu values .....                    | 45        |
| Confirming current settings .....            | 45        |
| Menu setting .....                           | 46        |

|  |           |
|--|-----------|
| Menu items and settings . . . . .                      | 47        |
| Initialising menu settings . . . . .                   | 55        |
| Adjusting TOF position . . . . .                       | 56        |
| Printer style (impact mode) settings . . . . .         | 57        |
| <b>Troubleshooting . . . . .</b>                       | <b>58</b> |
| Clearing paper jams . . . . .                          | 58        |
| Cut sheet paper jammed in printer. . . . .             | 58        |
| Continuous forms jammed in printer. . . . .            | 60        |
| Responding to alarm conditions . . . . .               | 62        |
| Responding to general problems. . . . .                | 62        |
| <b>Cleaning your printer . . . . .</b>                 | <b>68</b> |
| Printer exterior. . . . .                              | 68        |
| Printer interior . . . . .                             | 68        |
| <b>Consumables and accessories. . . . .</b>            | <b>70</b> |
| Consumables . . . . .                                  | 70        |
| Changing a ribbon cartridge . . . . .                  | 70        |
| Consumable order information. . . . .                  | 73        |
| <b>Specifications . . . . .</b>                        | <b>74</b> |
| ML1120 . . . . .                                       | 74        |
| ML1190 . . . . .                                       | 77        |
| <b>Index. . . . .</b>                                  | <b>80</b> |
| <b>Oki Printing Solutions contact details. . . . .</b> | <b>81</b> |

## NOTES, CAUTIONS AND WARNINGS.

---

*NOTE*

*A note provides additional information to supplement the main text.*

---

### **CAUTION!**

**A caution provides additional information which, if ignored, may result in equipment malfunction or damage.**

### **WARNING!**

**A warning provides additional information which, if ignored, may result in a risk of personal injury.**

# INTRODUCTION

Congratulations on purchasing this Oki Printing Solutions printer!

The ML1120 (9-pin) and ML1190 (24-pin) are designed to provide highly reliable letter quality printing and high resolution graphics for the desktop/office printing environment. Both models combine state-of-the-art serial impact dot matrix printing technology with advanced materials and superior construction to provide high performance and versatility in a desktop sized unit. Careful attention to ergonomics and application needs provides user friendly operation for operators of varying technical capabilities.

## ABOUT THIS GUIDE

---

*NOTE*

*Images used in this manual may include optional features that your printer does not have installed.*

---

This manual is your user's guide (check the web site, [www.okiprintingsolutions.com](http://www.okiprintingsolutions.com), for the most up-to-date version) for your printer and forms part of the overall user support listed below:

- > **Installation Safety booklet:** to provide information for safe use of the printer.

This is a paper document that is packaged with the printer and should be read before setting up your printer.

- > **Set-up guide:** to describe how to unpack, connect and turn on your printer.

This is a paper document that is packaged with the printer.

- > This **User's Guide:** to help you to become familiar with your printer and make the best use of its many features. Also included are guidelines for troubleshooting and maintenance to ensure that it performs at its best. Additionally, information is provided for adding optional accessories as your printing needs evolve.

This is an electronic document stored on the manuals CD.

- > **Technical Reference Guide:** to provide detailed technical information for programmers and more technical users.

This is an electronic document available on the web site [www.okiprintingsolutions.com](http://www.okiprintingsolutions.com).

- > **Installation Guides:** accompany consumable items and optional accessories to describe how to install them.

These are paper documents that are packaged with the consumables and optional accessories.

- > **On-line Help:** on-line information accessible from the printer driver and utility software.

## ON-LINE USAGE

This guide is intended to be read on screen using an Adobe Acrobat Reader. Use the navigation and viewing tools provided in Acrobat.

You can access specific information in two ways:

- > In the list of bookmarks down the left hand side of your screen, click on the topic of interest to jump to the required topic. (If the bookmarks are not available, use the ["Contents" on page 3.](#))
- > In the list of bookmarks, click on Index to jump to the Index. (If the bookmarks are not available, use the ["Contents" on page 3.](#)) Find the term of interest in the alphabetically arranged index and click on the associated page number to jump to the page containing the term.

## PRINTING PAGES

The whole manual, individual pages, or sections may be printed. The procedure is:

1. From the toolbar, select File > Print (or press the Ctrl + P keys).

- 2.** Choose which pages you wish to print:
- (a) [All pages], (1), for the entire manual.
  - (b) [Current page], (2), for the page at which you are looking.
  - (c) [Pages from] and [to], (3), for the range of pages you specify by entering their page numbers.

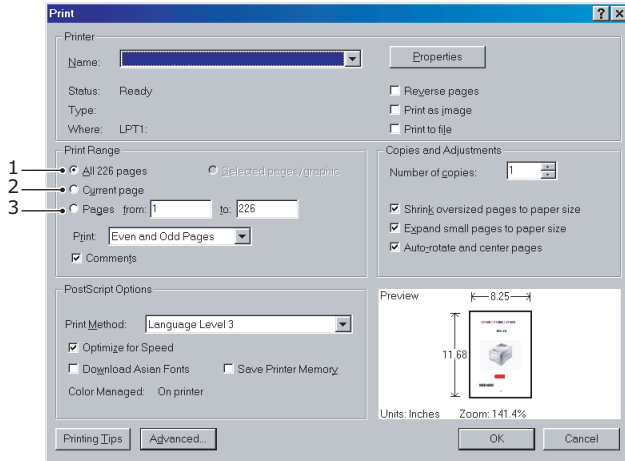

- (c) [Pages from] and [to], (3), for the range of pages you specify by entering their page numbers.
- 3.** Click on OK.



# GETTING STARTED

## WARNING!

**If you have not already done so, familiarise yourself with the content of the Installation Safety booklet supplied with your printer.**

### RETAINING PACKING MATERIALS

After setting up your printer according to the instructions in the Set-up Guide, retain your packing materials and container in case you ever need to ship or transport your printer.

### IDENTIFYING COMPONENT PARTS

The main parts of your printer are identified and briefly explained below.

#### FRONT VIEW

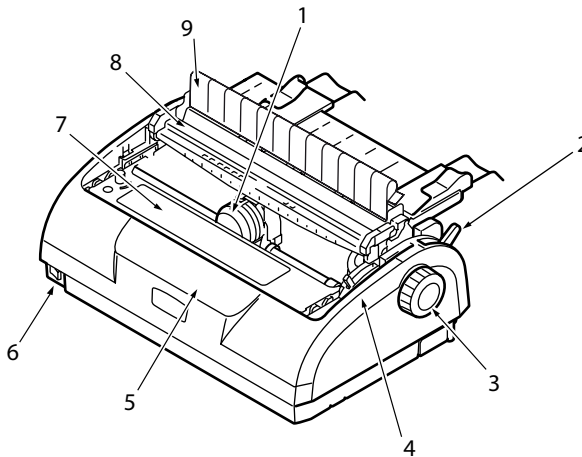

- 1.** Print Head: prints the characters on the paper.
- 2.** Paper Type Lever: set according to the type of paper used – cut sheet or continuous forms.

3. Platen Knob: turn to move or eject the paper.
4. Paper Thickness Lever: set according to the thickness of the paper. There is also a setting to facilitate ribbon replacement.
5. Control Panel: contains button switches and indicators (described in detail later) that allow you to operate the printer.

ML1120

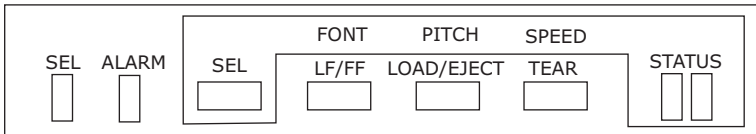

ML1190

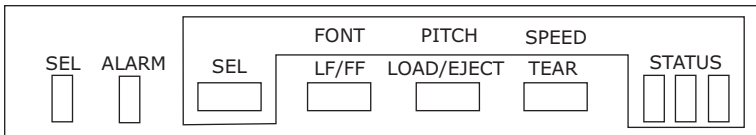

6. Power Switch: to turn the printer power ON/OFF.
7. Ribbon Cartridge: holds the printer ribbon.
8. Pull Up Roller Assembly: aids paper exit.
9. Pull Up Guide: prevents paper skew.

## REAR VIEW

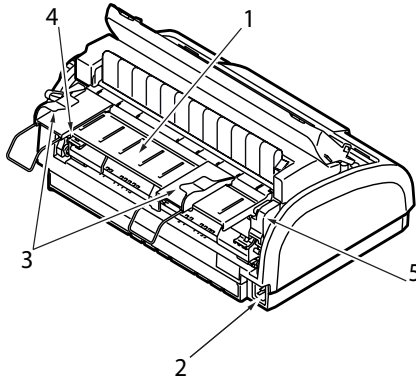

- 1.** Input Tray: insert cut sheet paper for use by the printer (one sheet at a time).
- 2.** Power connector: connect to printer power cable.
- 3.** Paper Guides: can be adjusted as required to locate the left edge of cut sheet paper.
- 4.** Pin Tractor: to load and feed continuous forms.
- 5.** Rear Cover.

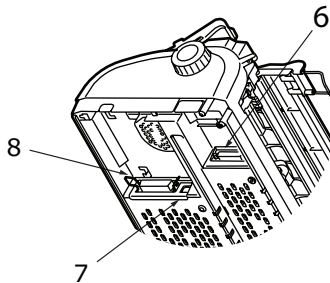

- 6.** Serial connector: connect to serial interface cable.
- 7.** USB connector: connect to USB interface cable.
- 8.** Parallel connector: connect to parallel interface connector.

## LOCATING YOUR PRINTER

- > Select a firm, solid, level surface on which to site your printer.
- > Allow enough space around your printer (e.g. at least 60 cm from any wall) for easy access to the Platen Knob and the various paper feed paths.

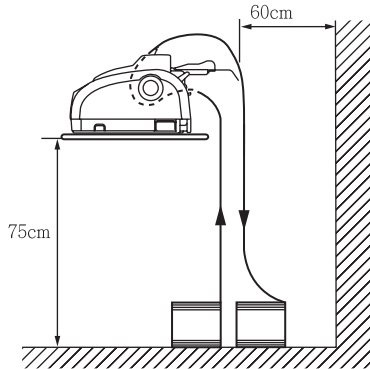

- > Make sure a grounded power outlet is available nearby.

## POWERING ON YOUR PRINTER

1. Ensure that your printer Power Switch is set to OFF.

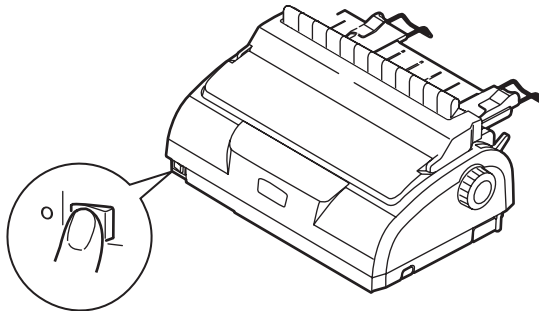

2. Connect the power cable (1) to the power connector (2) on the printer.

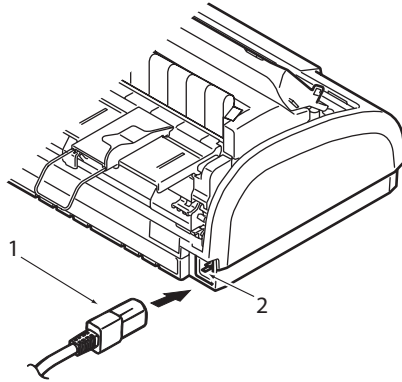

3. Connect the power cable to a 220/240 V AC power outlet and switch on the outlet power.
4. Turn the printer Power Switch to ON.



5. Check that the SEL and STATUS indicators on the control panel illuminate.

## PRODUCING A TEST PRINT

To check that your printer is operational, produce a test print on a sheet of 80 gsm A4 paper (for example) as follows:

### CAUTION!

**Allow at least 5 seconds between turning the printer ON after turning it OFF. A shorter time interval between turning ON/OFF operations may cause printer power failure.**

**Do not turn the printer OFF while it is printing as this may result in damage to the print head.**

- 1.** Turn the printer Power Switch to OFF.
  - 2.** Set the Paper Type Lever to cut sheet.
  - 3.** Remove the Access Cover and set the Paper Thickness Lever to position 1.
  - 4.** Press and hold the LF/FF and the LOAD/EJECT buttons and turn the Power Switch to ON. The ALARM indicator should be illuminated to indicate that there is no paper in the printer.
  - 5.** With the long side of the paper against the paper guide, insert the paper carefully into the printer. The printer will automatically grip the paper and start the test print.
- 

*NOTE*

*If required, you can pause the test print by pressing the SEL button and then resume the test print by again pressing the SEL button.*

---

- 6.** When the test print has completed, the paper is automatically ejected.
- 

*NOTE*

*If you want to stop the test print for any reason, press the SEL button followed by the LOAD/EJECT button to eject the paper. Turn the printer Power Switch to OFF.*

---

# CONNECTING TO A COMPUTER

In this section you will interconnect your printer and computer, install the printer driver in your computer and print a test page.

## INTERFACES

Your printer is equipped with three data interfaces:

### CAUTION!

**Do not use more than one of the following data interface methods to connect to your PC.**

- > Parallel: for direct connection to a PC. This port requires a bi-directional (IEEE 1284 compliant) parallel cable.
- > Serial: for direct connection to a PC. This port requires a bi-directional RS232C serial interface cable.
- > USB: for connection to a PC running Windows 98 or above. This port requires a shielded cable less than 5m long conforming to USB version 2.0.

---

*NOTE*

*Interface cables are not supplied with your printer.*

---

## INTERCONNECTION

1. Ensure that both printer and computer are turned OFF.
2. Connect the required interface cable, serial (1), USB (2), or parallel (3), to the printer and then to the computer.

Break off the tabs (4) to allow the cables to sit neatly underneath the printer.

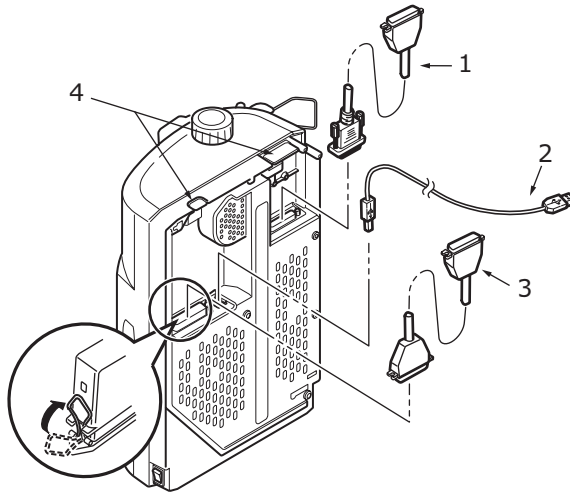

3. Turn ON the printer.
4. Turn ON the computer.

## INSTALLING THE PRINTER DRIVER

Insert the Drivers CD into your computer and follow the on-screen instructions to install the printer driver for use with your printer.

## PRINTING A TEST PAGE

As an example, using Windows XP:

1. Use Start > Printers and Faxes to show the Printers and Faxes window.
2. Highlight the driver for your printer.
3. Use File > Properties to show the Properties window.
4. On the General tab, click the Print Test Page button.
5. Ensure that a test page has printed, verifying your printer – computer setup.



## **PRINTING FROM A COMPUTER**

When printing to your printer from, for example, a Windows application on your computer, make your printing selections from the driver windows that appear on screen. These driver windows have been designed to be easy to use and intuitive while supplementary on-line help is available by clicking each window Help button.

# PAPER HANDLING

This section describes how to use cut sheet paper and continuous forms in your printer.

## LOADING CUT SHEET PAPER

1. Ensure that the printer is switched ON.

---

**NOTE**

*If there are any continuous forms in the printer, eject them as described in "Removing continuous forms" on page 36.*

---

2. Ensure that the Pin Tractor covers are closed to avoid the possibility of paper jams.

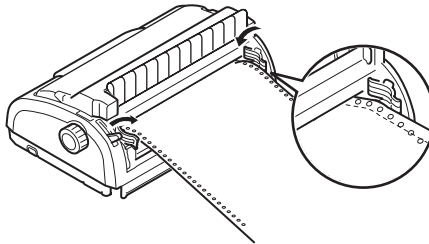

3. Ensure the Paper Type Lever (1) is set to Cut Sheet. 

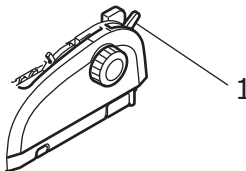

4. Set the left paper margin by adjusting the Paper Guide (1). Position the edge of the Paper Guide (1) at the tip of the Printed Line Marker arrow (2) on the Paper Tray.

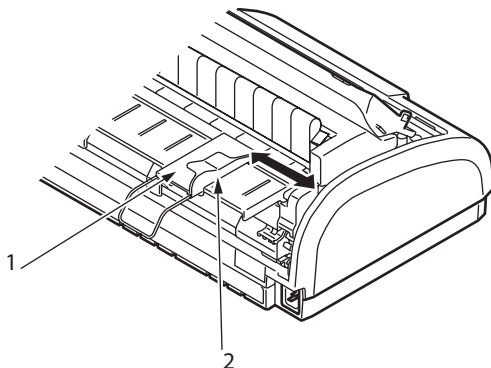

5. Remove the Access Cover and set the Paper Thickness Lever (1) to suit the paper. See ["Setting the Paper Thickness lever"](#) on page 38.

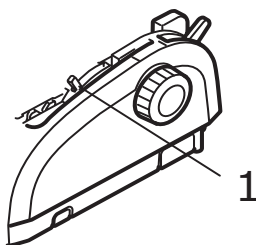

### CAUTION!

**If the Paper Thickness Lever setting does not match the paper being used, paper feeding and printing may not work properly.**

6. With the printing side facing downwards and the left edge aligned with the Paper Guide (1), carefully insert the

paper on the Input Tray (2) into the printer until it is gripped.

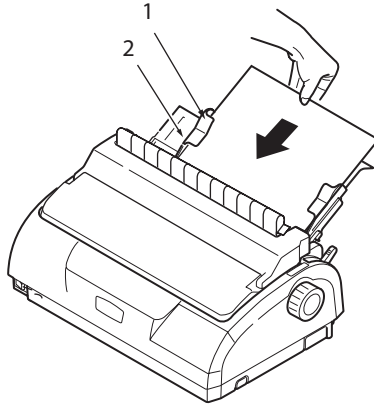

---

**NOTE**

*Ensure that the paper is accurately aligned along the Paper Guide to avoid the possibility of skew printing.*

*When printing an envelope, do not fold up the flap. A flap aligned along the Paper Guide can lead to skew printing.*

---

## **EJECTING CUT SHEET PAPER**

When the printer reaches the end of the cut sheet page it automatically ejects the page. If required, add another sheet for the printer to continue printing from where it left off.

To eject a cut sheet left in the printer, carry out the following:

- 1.** Press the SEL button to put the printer off-line.
- 2.** Press the LOAD/EJECT button and the paper is ejected to the Paper Tray.

---

**NOTE**

*Paper longer than A4 length (297 mm) may overlap and possibly fall off the Paper Tray.*

---

## LOADING CONTINUOUS FORMS

### SETTING UP CONTINUOUS FORMS

To avoid paper feeding problems, carry out the following:

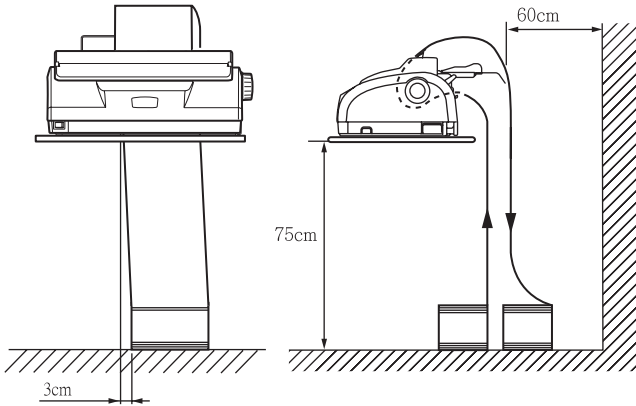

1. Check your printer is on a surface approximately 75 cm above the floor.
2. Position the continuous forms supply directly below the printer, no more than 3 cm left or right of the printer paper path.
3. Ensure the rear of the printer is close to and parallel with the edge of the surface and at least 60 cm from any wall.

### FEEDING CONTINUOUS FORMS (REAR FEED)

1. Ensure that the printer is turned ON.

---

#### NOTE

If there is a cut sheet in the printer, eject it as described in ["Ejecting cut sheet paper" on page 20](#).

---

2. Set the Paper Type Lever to Continuous Forms 

3. Remove the Access Cover and set the Paper Thickness Lever (1) to suit the paper. See "Setting the Paper Thickness lever" on page 38.

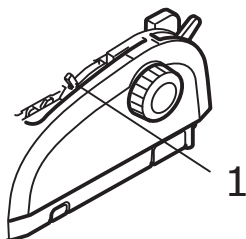

---

**NOTE**

*If the Paper Thickness Lever setting does not match the paper being used, paper feeding and printing may not work properly.*

---

4. Remove the Input Tray and Rear Cover together by gripping the Input Tray at both sides and pulling it up and away from the printer.

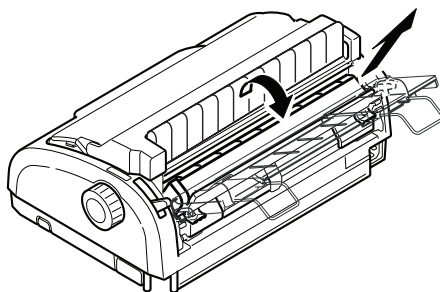

5. Lift the locking lever (1) of the left Pin Tractor and slide the Pin Tractor as required to adjust the paper position.

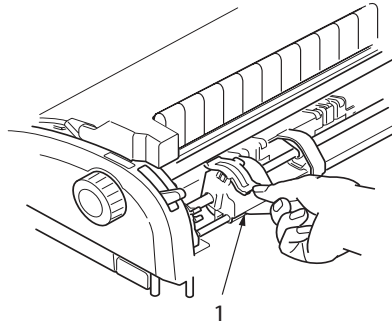

Press the locking lever back down to lock the Pin Tractor in the desired position.

6. Lift the locking lever (1) of the right Pin Tractor and slide the Pin Tractor to the required position to accommodate the width of the continuous forms to be used. Move the rear paper guide (2) to midway between the left (3) and right (4) Pin Tractors.

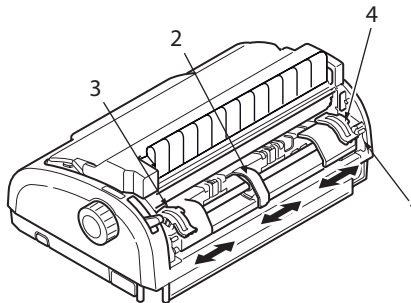

7. Open the left and right Pin Tractor covers and feed the continuous forms in the direction of the arrows, locating the sprocket holes in the forms onto the sprocket pins.

Ensure that the forms are properly aligned on the sprocket pins, then close the Pin Tractor covers.

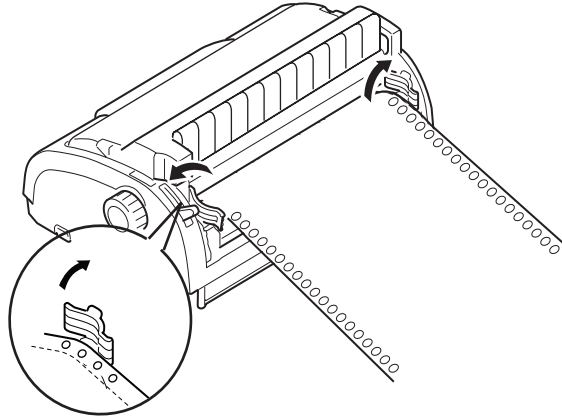

- Adjust the right Pin Tractor to accommodate the width of the continuous forms, taking care that the forms are held neither too loosely nor too tightly between the Pin Tractors. Press the locking lever down to lock the right Pin Tractor in the desired position.

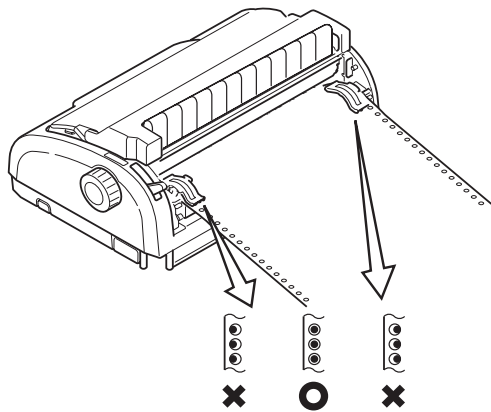

- Replace the Input Tray and Rear Cover by fitting the Rear Cover into the grooves at the back of the printer and



pushing gently forward until the Input Tray clips into place.

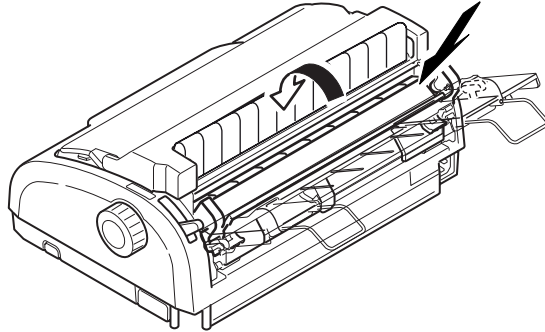

10. Replace the Access Cover.
11. Press the LOAD/EJECT button. The continuous forms will be taken into the printer and positioned at the first line print position.

### FEEDING CONTINUOUS FORMS (BOTTOM FEED)

---

*NOTE*

*If there is a cut sheet in the printer, eject it as described in ["Ejecting cut sheet paper" on page 20.](#)*

---

### Moving tractor assembly

1. Ensure that the printer is switched OFF.

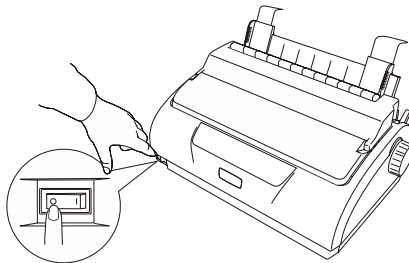

2. Disconnect the power cord.

3. Remove the Access Cover.

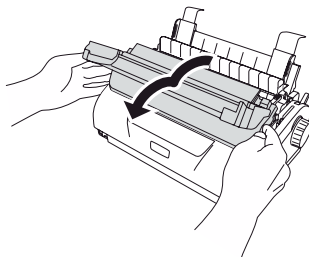

**WARNING!**

**Be careful as the printhead may be hot after operation. Allow it to cool before touching it.**

4. Move the printhead assembly to the left.

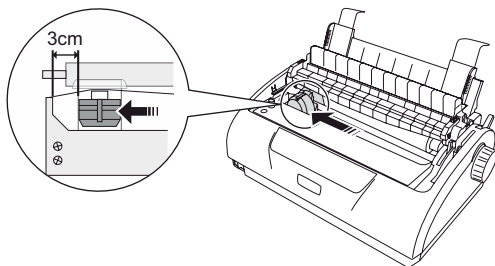

- 5.** Push up the Pull Up Roller Assembly with the thumbs and release one side. Then, release the other side and remove the Pull Up Roller Assembly. The Pull Up Guide may become detached.

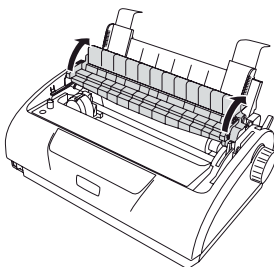

- 6.** If necessary, replace the Pull Up Guide.
- 7.** Turn the printer, so that the back of the printer is facing you.

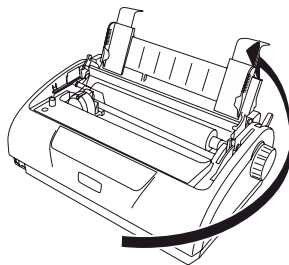

8. Remove the Input Tray and Rear Cover together by gripping the Input Tray at both sides and pulling it back and up from the printer.

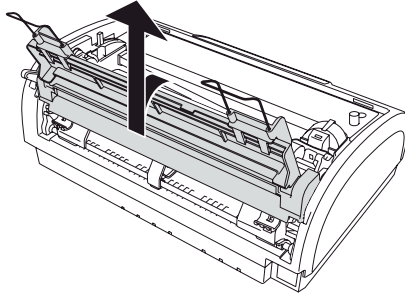

9. Remove the tractor assembly. Squeeze the handles to release the clamps on both sides. Continue to squeeze and rotate and lift the assembly out of the printer.

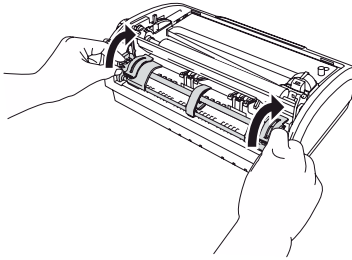

- 10.** Position the tractor assembly as shown. The gear assembly is on the left.

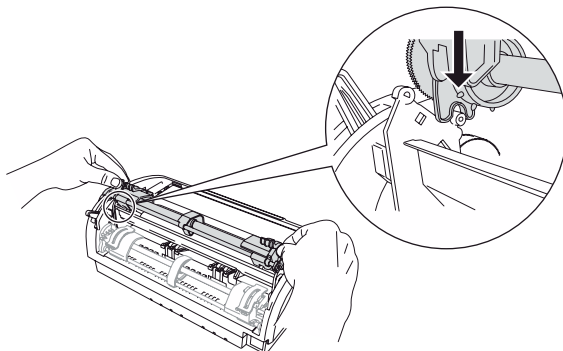

- 11.** Locate the arms over the pivot points and rotate the unit backwards until the clamps close over the back pins.
- 12.** Turn the printer so that the front of the printer is facing you.

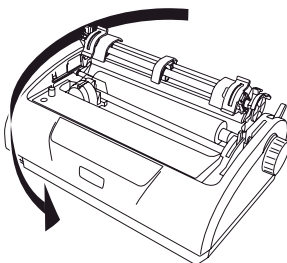

- 13.** Turn the Platen Knob. If the tractor assembly is correctly installed, the gear will turn. If the gear does not turn as you turn the Platen Knob, repeat steps 10 to 12.

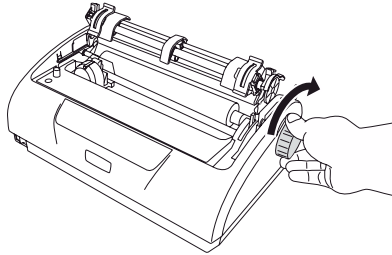

- 14.** Replace the Input Tray and Rear Cover by fitting the Rear Cover into the grooves at the back of the printer and pulling gently forward until the Input Tray clips into place.

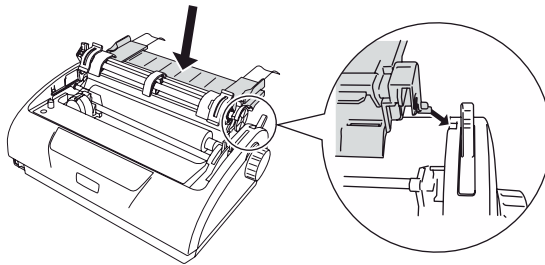

- 15.** Replace the Access Cover.

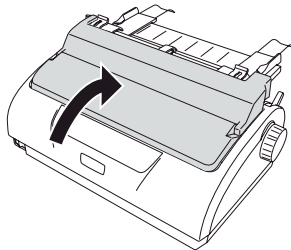

## Loading continuous forms (bottom feed)

1. Ensure the printer is turned off.

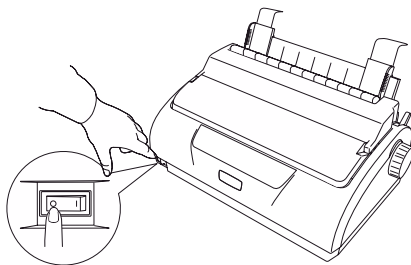

2. Remove the Access Cover.

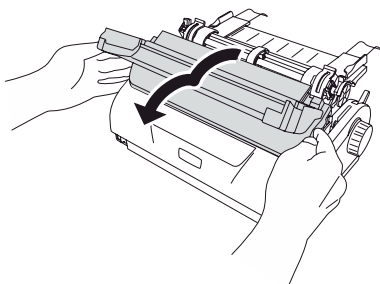

3. Set the Paper Type Lever to Continuous Forms 

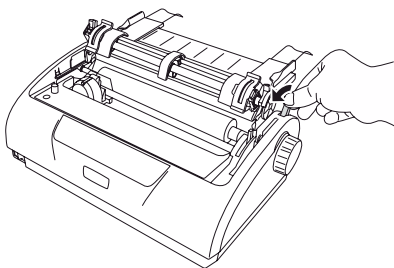

4. Place the stack of continuous forms paper below the printer. Bring the paper up through the slot in the base of the printer.

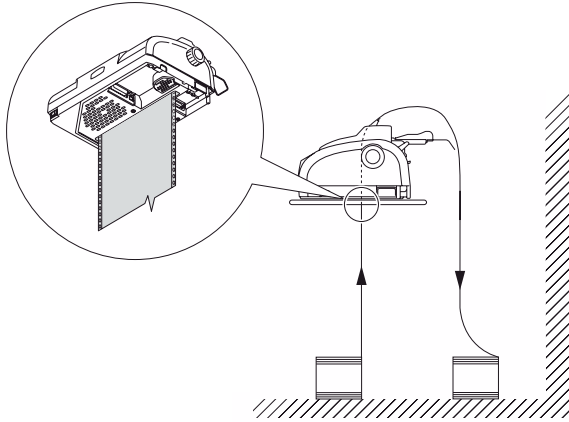

5. Lift the locking lever (1) of the left Pin Tractor and slide the Pin Tractor as required (2) to adjust the paper position then press the locking lever (3) back down to lock the Pin Tractor in the desired position.

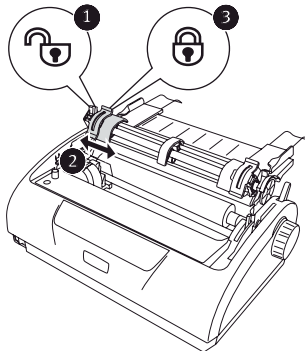

6. Lift the locking lever (1) of the right Pin Tractor and slide the Pin Tractor to the required position (2) to accommodate the width of the continuous forms to be



used. Move the rear paper guide (3) to midway between the left and right Pin Tractors.

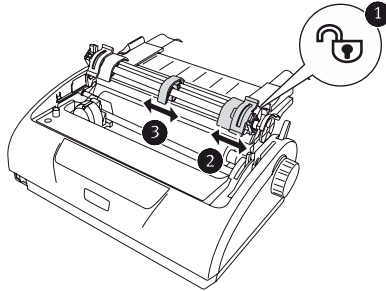

7. Open the left and right Pin Tractor covers (1) and feed the continuous forms (2) in the direction of the arrow, locating the sprocket holes in the forms onto the sprocket pins.

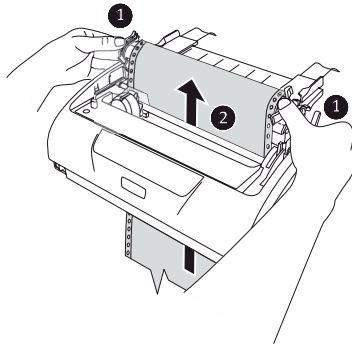

8. Ensure that the forms are properly aligned on the sprocket pins, then close the Pin Tractor covers.

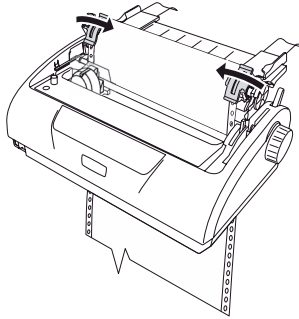

9. Adjust the right Pin Tractor (1) to accommodate the width of the continuous forms, taking care that the forms are held neither too loosely nor too tightly between the Pin Tractors. Press the locking lever down (2) to lock the right Pin Tractor in the desired position.

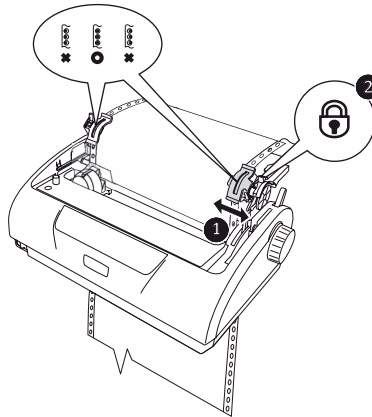

10. Replace the Access Cover.

11. Turn ON the printer.

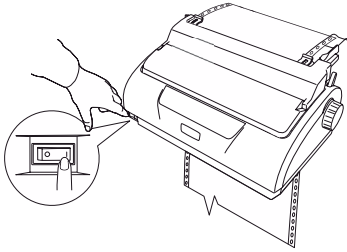

## TEARING OFF CONTINUOUS FORMS

1. With the SEL indicator illuminated, press and hold the LF/FF button to move the continuous form to the next page.
2. Press TEAR to align the tear-off perforations on the form with the paper cutter on the printer.
3. Carefully tear off the forms along the tear-off perforations using the paper cutter as a guide. Using excessive force may result in tearing at a position other than the tear-off perforations.
4. Press the TEAR button to reposition the continuous forms in the printer back to the first line print position.

## ALIGNING THE TEAR-OFF PERFORATIONS

If the tear-off perforations are not aligned with the paper cutter, align them as follows:

1. Remove the Access Cover of your printer.
2. With the SEL indicator illuminated, press and hold the TEAR button to move the tear-off perforations to the paper cutter.

3. Check the position of the tear-off perforations (1) relative to the paper cutter (2).

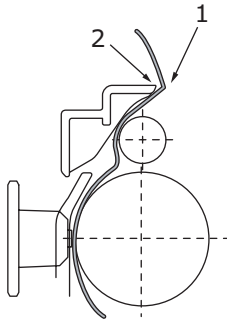

- (a) To advance the forms, continue to hold down the TEAR button and then the SEL button.
- (b) To retract the forms, continue to hold down the TEAR button and the LF/FF button.

---

*NOTE*

*If a movement greater than  $\pm 0.366$  mm (1/144 in) is specified, the above adjustment cannot be made.*

---

4. Release the buttons after the tear-off perforations have been aligned with the paper cutter.

## REMOVING CONTINUOUS FORMS

1. Tear off the continuous forms. [See "Tearing off continuous forms" on page 35.](#)
2. Press the SEL button to set the printer off-line and reposition the continuous forms in the printer.
3. Press the LOAD/EJECT button to move the front edge of the continuous forms backwards to the Pin Tractors.

---

*NOTE*

*If sprocket holes of the last page of the forms disengage from the sprocket pins, do not attempt to eject the paper to avoid the possibility of a paper jam.*

---

4. Remove the Input Tray and Rear Cover together by gripping the Input Tray at both sides and pulling it up and away from the printer.

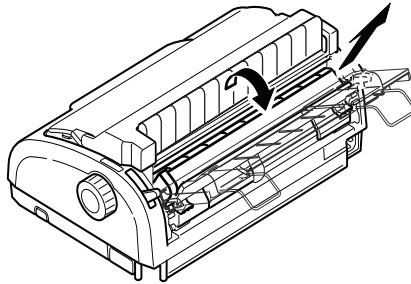

5. Lift the Pin Tractor covers and remove the forms.

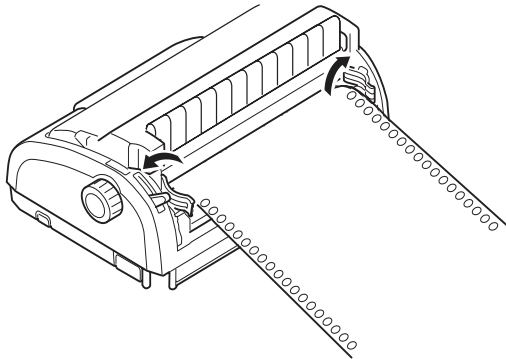

6. Close the Pin Tractor covers.
7. Replace the Input Tray and Rear Cover by fitting the Rear Cover into the grooves at the back of the printer and

pushing gently forward until the Input Tray clips into place.

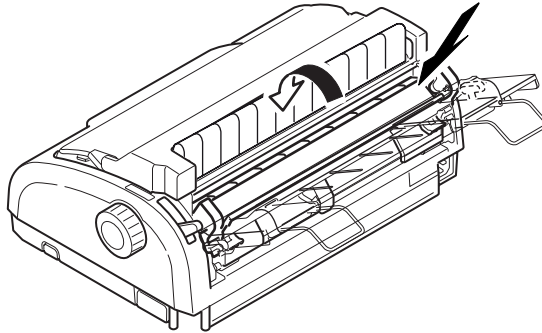

## SETTING THE PAPER THICKNESS LEVER

There are 6 lever positions, the first 5 for printing purposes and the sixth to facilitate ribbon replacement.:

Set the Paper Thickness lever for different paper types as follows:

| PAPER TYPE  | LEVER POSITION |   |   |   |           |
|---|----------------|---|---|---|-----------|
|   | 1              | 2 | 3 | 4 | 5 - 6     |
| Cut sheet paper                                   |                |   |   |   | See below |
| 52 – 80 gsm                                       | X              |   |   |   |           |
| 81 – 127 gsm                                      |                | X |   |   |           |
| Envelope  |                |   |   | X |           |
| Carbon paper or Pressure-sensitive paper (40 gsm) |                |   |   |   | See below |
| 2 part  |                | X |   |   |           |
| 3 part  |                | X |   |   |           |
| 4 part  |                |   | X |   |           |
| 5 part  |                |   | X |   |           |
| 6 part  |                |   |   | X |           |

Set the Paper Thickness lever for overall paper thickness as follows:

| OVERALL PAPER THICKNESS | LEVER POSITION |
|-------------------------|----------------|
| 0.06 – 0.10 mm          | 1              |
| 0.11 – 0.18 mm          | 2              |
| 0.19 – 0.25 mm          | 3              |
| 0.26 – 0.32 mm          | 4              |
| 0.33 – 0.39 mm          | 5              |
| 0.40 – 0.46 mm          | 6              |

---

**NOTE**

*Printing with lever positions 5 – 6 is not guaranteed.*

*If the lever position does not suit the paper thickness, paper feeding and printing may not work properly.*

*Do not print bankbooks to avoid possible pin breakage/ribbon snagging.*

*Printing can be carried out with the lever position set to 4 for paper thickness up to 0.32 mm.*

*When lever positions 5-6 are selected, printing quality for carbon paper may decline resulting in illegible characters for example.*

---

# OPERATING INSTRUCTIONS

## CONTROL PANEL

### ML1120

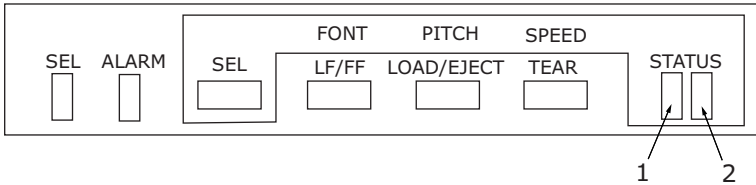

The status/alarm indicators and button switches on the control panel allow you to check printer status and control the printer.



## Indicators

| INDICATOR                     | STATUS   | MEANING  |
|-------------------------------|----------|--|
| SEL                           | ON       | Printer is on-line i.e. is available to print  |
|                               | OFF      | Printer is off-line i.e. is not available to print   |
|                               | Flashing | When flashing together with the ALARM indicator, printing cannot be resumed at this stage. Turn the power OFF, verify that the carriage moves properly, then turn the power ON again.<br>If the problem is still there after you turn the power ON again, contact your dealer. |
| ALARM                         | ON       | If printing, indicates lack of paper, i.e. no paper present.   |
|                               | OFF      | Paper present status   |
|                               | Flashing | Paper jam alarm status   |
|                               |          | Media switch alarm status  |
|                               |          | When flashing together with the SEL indicator, printing cannot be resumed at this stage. Turn the power OFF, verify that the carriage moves properly, then turn the power ON again.<br>If the problem is still there after you turn the power ON again, contact your dealer.   |
| High temperature alarm status |          |  |
| STATUS                        |          |  |
| 1                             | ON       | Menu printing mode   |
|                               | OFF      | Normal printing mode   |
|                               | Flashing | High temperature indication  |
| 2                             | ON       | Quiet print mode   |
|                               | OFF      | Normal speed printing mode   |
|                               | Flashing | High multipart printing mode   |

**ML1190**

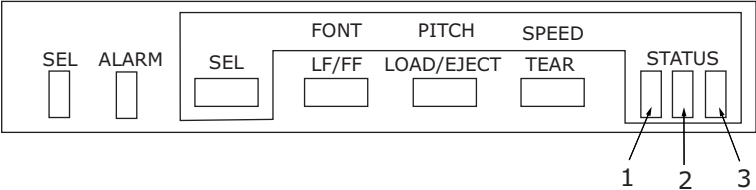

The status/alarm indicators and button switches on the control panel allow you to check printer status and control the printer.

## Indicators

| INDICATOR                     | STATUS   | MEANING  |
|-------------------------------|----------|--|
| SEL                           | ON       | Printer is on-line i.e. is available to print  |
|                               | OFF      | Printer is off-line i.e. is not available to print   |
|                               | Flashing | When flashing together with the ALARM indicator, printing cannot be resumed at this stage. Turn the power OFF, verify that the carriage moves properly, then turn the power ON again.<br>If the problem is still there after you turn the power ON again, contact your dealer. |
| ALARM                         | ON       | Paper end status i.e. no paper present   |
|                               | OFF      | Paper present status   |
|                               | Flashing | Paper jam alarm status   |
|                               |          | Media switch alarm status  |
|                               |          | When flashing together with the SEL indicator, printing cannot be resumed at this stage. Turn the power OFF, verify that the carriage moves properly, then turn the power ON again.<br>If the problem is still there after you turn the power ON again, contact your dealer.   |
| High temperature alarm status |          |  |
| STATUS                        |          |  |
| 1                             | ON       | Menu printing mode   |
|                               | OFF      | Normal printing mode   |
|                               | Flashing | High temperature indication  |
| 2                             | ON       | Quiet print mode   |
|                               | OFF      | Normal speed printing mode   |
|                               | Flashing | High multipart printing mode   |
| 3                             | ON       | Printer power is ON  |
|                               | OFF      | Printer power is OFF   |
|                               | Flashing | Low power consumption mode   |

## BUTTONS

| BUTTON              | STATUS  | FUNCTION  |
|---------------------|---|---|
| SEL                 | On-line                                       | Sets the printer to off-line.   |
|                     | Off-line                                      | Sets the printer to on-line and disarms the printer.  |
| LF/FF               | On-line                                       | Feeds paper by one line. Holding the button down results in continuous line feeding.  |
|                     | Off-line                                      | Performs continuous line feeding.<br>Ejects the cut sheet.  |
| LOAD/EJECT          | On-line and off-line<br>Continuous Forms mode | Continuous form fed until first line of next page<br>If the continuous form is in position, press to retract the form to the Pin Tractors.<br>(If the sprocket holes of the last page of the form disengage from the sprocket pins, do not attempt to eject the paper as a paper jam may result.) |
|                     | On-line and off-line<br>Cut sheet manual mode | Ejects the cut sheet  |
| TEAR                | On-line<br>Continuous Forms mode              | Delivers the continuous form to the cut position. If the button is pressed again or data is received, the original form position is restored.   |
|                     | On-line<br>Cut sheet manual mode              | Ineffective   |
|                     | Off-line                                      | Ineffective   |
| SEL+POWER ON Switch |   | Enters menu mode.   |
| LOAD/EJECT+SEL      | On-line and off-line                          | Microfeed down 0.366 mm (1/144 in) step.  |
| LOAD/EJECT+LF/FF    | On-line and off-line                          | Microfeed up 0.366 mm (1/144 in) step.  |

| BUTTON     | STATUS               | FUNCTION  |
|------------|----------------------|---|
| TEAR+SEL   | On-line and off-line | Microfeed down (0.366 mm (1/144 in) step at tear-off position only.   |
| TEAR+LF/FF | On-line and off-line | Microfeed up 0.366 mm (1/144 in) step at tear-off position only.  |
| SEL+TEAR   | On-line              | Quieter print mode<br>Each press of the button pair progresses the printer through Quieter print mode<br>> High multipart print mode<br>> Normal print mode |
|            | Off-line             | Ineffective   |

## SETTING MENU VALUES

The following information explains the printer settings and how you can change them. Printer items and their values are printed for reference.

### CONFIRMING CURRENT SETTINGS

To print the current menu settings, use a cut sheet of A4 paper or continuous forms of width at least 254 mm. In this example, a sheet of A4 paper is used.

1. Set the Paper Type lever to cut sheet mode.
2. To activate menu mode:
  - (a) Ensure that the printer is powered OFF.
  - (b) While holding down the SEL button set the printer Power Switch to ON.
3. Place the cut sheet on the Paper Tray. The printer prints the firmware details.
4. Press the TEAR button to print out the current menu settings.

5. Exit or proceed to change menu settings:
  - (a) To exit menu settings confirmation, save the current settings and eject the paper, press and hold TEAR, then press LOAD/EJECT and then LF/FF.
  - (b) To change menu settings, see ["Menu setting" on page 46](#).

## MENU SETTING

---

### *NOTE*

*Before changing menu settings, you may wish to print the current menu settings as in ["Confirming current settings" on page 45](#).*

---

Set menu item values (printed out for reference as you proceed) as follows:

1. While holding down the SEL button set the printer Power Switch to ON.
  2. Place the cut sheet on the Paper Tray.
  3. Press SEL (or TEAR and SEL together) to step forward (backward) through the main menu.
  4. Press LF/FF (or TEAR and LF/FF together) to step forward (backward) through the sub-menus.
  5. Press LOAD/EJECT (or TEAR and LOAD/EJECT together) to step forward (backward) through the settings for each menu item.
  6. Repeat steps 3 to 5 as required to change settings for other menu items.
  7. To exit menu settings confirmation, save the current settings and eject the paper, press and hold TEAR, then press LOAD/EJECT and then LF/FF.
- 

### *NOTE*

*Switching the printer OFF does not save the new settings.*

---

## MENU ITEMS AND SETTINGS

In the menu settings tables below, factory default settings are shown in bold.

| MENU                 | ITEM                 | FUNCTION   | SETTING  |
|----------------------|----------------------|--|--|
| Printer control menu | Emulation Mode       | Select EPSON mode, IBM mode, or ML mode.           | IBM<br>EPSON<br>ML   |
| Font menu            | Print Mode           | Select quality of ANK characters.                  | NLQ Courier<br>NLQ Gothic<br>NLQ OCR-B<br>DRAFT<br>Utility |
|                      | Draft Mode           | Select HSD or SSD.                                 | HSD<br>SSD   |
|                      | Pitch                | Select character pitch.                            | <b>10 CPI</b> , 12 CPI, 15 CPI, 17.1 CPI, 20 CPI           |
|                      | Proportional Spacing | Select whether to use proportional spacing or not. | Yes<br><b>No</b>   |
|                      | Style                | Select either font style.                          | <b>Normal</b> , Italics                                    |
|                      | Size                 | Select the character scale size.                   | <b>Single</b> , Double                                     |

| MENU             | ITEM           | FUNCTION   | SETTING  |
|------------------|----------------|--|--|
| Symbol sets menu | Character Set  | Select either ANK character code table.  | Standard Line Graphics<br>Block Graphics (displayed for ML emulation only)<br><br>Set I<br>Set II (displayed for IBM and EPSON emulation only)   |
|                  | Language Set   | Select a language character set.   | <b>ASCII</b> , French, German, British, Danish I, Swedish I, Italian, Spanish I, Japanese, Norwegian, Danish II, Spanish II, Latin American, French Canadian, Dutch, TSR80, Swedish II, Swedish III, Swedish IV, Turkish, Swiss I, Swiss II, Publisher |
|                  | Zero Character | Select either print font pattern to receive a zero character located at 30H in ANK code or at AA30H in a single-byte code. | <b>Unslashed</b><br>Slashed  |



| MENU             | ITEM                | FUNCTION   | SETTING  |
|------------------|---------------------|--|--|
| Symbol sets menu | Code Page           | Select a code page.  | <b>USA</b><br>Canada French<br>Multilingual<br>Portugal<br>Norway<br>Turkey<br>Greek_437<br>Greek_869<br>Greek_928<br>Grk_437 CYPRUS<br>Polska Mazovia<br>Serbo Croatian I<br>Serbo Croatian II<br>ECMA-94<br>Hungarian CWI<br>Windows Greek<br>Windows East<br>Europe Windows<br>Cyrillic<br>East Europe Latin<br>II-852<br>Cyrillic I-855<br>Cyrillic II-866<br>Kamenicky(MJK)<br>ISO Latin 2<br>Hebrew NC (862)<br>Hebrew OC<br>Turkey_857<br>Latin 5 (Windows<br>Turkey)<br>Windows Hebrew<br>Ukrainian<br>Bulgarian<br>ISO Latin 6 (8859/<br>10) Windows Baltic<br>Baltic_774<br>KBL-Lithuanian<br>Cyrillic Latvian<br>Roman-8<br>Icelandic-861<br>Multilingual 858<br>ISO 8859-15<br>Greek_737<br>Asmo449+<br>Asom708<br>Arabic864<br>Windows Arabic |
|                  | Slashed Letter<br>0 | Set whether to convert slashed 0 located at 9BH and 9DH in USA code page or not. | Yes<br><b>No</b>   |

| MENU           | ITEM  | FUNCTION  | SETTING   |
|----------------|---|---|---|
| Rear feed menu | Line Spacing                                    | Select line feed pitch.   | <b>6 LPI</b><br>8 LPI   |
|                | Form Tear-Off                                   | Select manual or auto as the method to advance a continuous form to the form tear-off position.   | <b>Off</b><br>500 ms<br>1 sec<br>2 sec  |
|                | Skip Over Perforation                           | Select whether to skip over perforation or not. (When a skip over perforation setup command is received, the received command is given priority.) | Yes (25.4 mm/ 1 in)<br><b>No</b>  |
|                | Page Length                                     | Select the length of a continuous form.   | 279.4 mm(11 in)<br>296.3 mm<br>(11 2/3 in)<br>304.8 mm (12 in)<br>355.6 mm(14 in)<br>431.8 mm(17 in)<br>127.0 mm(5 in)<br>76.2 mm(3 in)<br>82.6 mm(3.25 in)<br>84.7 mm(10/3 in)<br>93.1 mm(11/3 in)<br>101.6 mm(4 in)<br>139.7 mm(5.5 in)<br>152.4 mm(6 in)<br>177.8 mm(7 in)<br>203.2 mm(8 in)<br>215.9 mm(8.5 in) |
|                | Initial Position (Paper position when power on) | This is the position of the paper when the paper is already loaded at power on. (For continuous form mode only.)                                  | <b>Print</b><br>Tear OFF  |
|                | Cut position adjust                             | Select an adjustment value for the position to cut the end of a continuous form. (In 1/90 in increments)  | -20 - -1<br><b>0</b><br>+20 - +1  |

| MENU           | ITEM                                | FUNCTION  | SETTING  |
|----------------|-------------------------------------|---|--|
| Rear feed menu | TOF adjustment (continuous)         | Select an adjustment value for the reference position in regard to the TOF position of a continuous form.<br><br>The position moves to the rear of the form by [+] and to the top of the form by [-] in 1/60 in increments. | -20 - -1<br><b>0</b><br>+20 - +1   |
|                | TOF (continuous)                    | Select the reference position for the TOF position when auto loading continuous form paper from the rear of the printer. (Up to the mid-section of characters in the first line.)   | 2.12 mm (1/12 in)<br>4.23 mm (1/6 in)<br>6.35 mm (1/4 in)<br>8.47 mm (1/3 in)<br>10.58 mm (5/12 in)<br>12.7 mm (1/2 in)<br>14.82 mm (7/12 in)<br>16.93 mm (2/3 in)<br>19.05 mm (3/4 in)<br>21.17 mm (5/6 in)<br><b>23.28 mm (11/12 in)</b><br>25.4 mm (1 in)<br>27.52 mm (13/12 in)<br>Use top of form |
|                | Continuous paper LF adjust          | Select an adjustment value for the line feed position.  | -2<br>-1<br><b>0</b><br>+1<br>+2   |
|                | Centring for paper top (continuous) | Find centre position  | <b>Valid</b><br>Invalid  |

| MENU             | ITEM                  | FUNCTION  | SETTING   |
|------------------|-----------------------|---|---|
| Bottom feed menu | Line Spacing          | Select line feed pitch.   | <b>6 LPI</b><br>8 LPI   |
|                  | Skip Over Perforation | Select whether to skip over perforation or not. (When a skip over perforation setup command is received, the received command is given priority.) | Yes (25.4 mm/1 in)<br><b>No</b>   |
|                  | Page Length           | Select the length of a continuous form.   | 279.4 mm(11 in)<br>296.3 mm<br>(11 2/3 in)<br><b>304.8 mm (12 in)</b><br>355.6 mm(14 in)<br>431.8 mm(17 in)<br>127.0 mm(5 in)<br>76.2 mm(3 in)<br>82.6 mm(3.25 in)<br>84.7 mm(10/3 in)<br>93.1 mm(11/3 in)<br>101.6 mm(4 in)<br>139.7 mm(5.5 in)<br>152.4 mm(6 in)<br>177.8 mm(7 in)<br>203.2 mm(8 in)<br>215.9 mm(8.5 in)  |
| Top feed menu    | Line Spacing          | Select line feed pitch.   | <b>6 LPI</b><br>8 LPI   |
|                  | Page Length           | Select the page length of cut paper.  | 279.4 mm(11 in);<br>296.3 mm<br>(11 2/3 in)<br><b>304.8 mm (12 in)</b><br>355.6 mm(14 in)<br>431.8 mm(17 in)<br>127.0 mm(5 in)<br>76.2 mm(3 in)<br>82.6 mm(3.25 in)<br>84.7 mm(10/3 in)<br>93.1 mm(11/3 in)<br>101.6 mm(4 in)<br>139.7 mm(5.5 in)<br>152.4 mm(6 in)<br>177.8 mm(7 in)<br>203.2 mm(8 in)<br>215.9 mm(8.5 in) |

| MENU          | ITEM                          | FUNCTION   | SETTING  |
|---------------|-------------------------------|--|--|
| Top feed menu | Top feed wait time            | Select the waiting time between setting paper on the tray and feeding it while the printer is waiting for paper to be fed in cut-paper manual feed mode.   | Invalid<br>500 ms<br>1 sec<br>2 sec  |
|               | Page length control           | Control the page length of cut paper.  | by MENU setting<br><b>by Actual page length</b>  |
|               | Cut sheet auto eject Position | Select a printable area at the bottom of cut sheets of paper in cut-paper mode (the character centre position).  | <b>6.35 mm (1/4 in)</b><br>12.70 mm (6/12 in)<br>14.82 mm (7/12 in)  |
|               | TOF Adjustment (Cut Sheet)    | Select an adjustment value for the reference position in regard to the TOF position of cut-paper/ passbooks.<br><br>The position moves to the rear of the form by [+] and to the top of the form by [-] in 1/60 in increments. | -20 - -1<br>0<br>+20 - +1  |
|               | TOF (cut sheet top of form)   | Select the reference position for the TOF position when feeding cut-paper in manual mode. (Up to the mid-section of characters in the first line.)   | 2.12 mm (1/12 in)<br>4.23 mm (1/6 in)<br><b>6.35 mm (1/4 in)</b><br>8.47 mm (1/3 in)<br>10.58 mm (5/12 in)<br>12.7 mm (1/2 in)<br>14.82 mm (7/12 in)<br>16.93 mm (2/3 in)<br>19.05 mm (3/4 in)<br>21.17 mm (5/6 in)<br>23.28 mm (11/12 in)<br>25.4 mm (1 in)<br>27.52 mm (13/12 in)<br>Use top of form |
|               | Cut sheet LF adjustment       | Adjust a line feed amount in cut-paper mode.   | -14 - -1<br><b>0</b><br>+14 - +1   |

| MENU        | ITEM                     | FUNCTION   | SETTING                                    |
|-------------|--------------------------|--|--|
| Set-up menu | Graphics                 | Select the printing direction when double-height print data exists in a line.  | <b>Bi-directional</b><br>Uni-directional   |
|             | Receive buffer size      | Select size of the received buffer.  | 1line<br>32 K<br><b>64 K</b>               |
|             | Paper out override       | Select whether to detect paper end or not.   | <b>No</b><br>Yes                           |
|             | Print Registration 1     | Adjust the print starting position on printing in the reverse direction. (The position moves to the right or left in 1/720 in increments.) | -10 - -1<br><b>0</b><br>+10 - +1           |
|             | Print Registration 2     | Adjust the print starting position on printing in the reverse direction. (The position moves to the right or left in 1/720 in increments.) | -10 - -1<br><b>0</b><br>+10 - +1           |
|             | -Print Registration 3    | Adjust the print starting position on printing in the reverse direction. (The position moves to the right or left in 1/720 in increments.) | -10 - -1<br><b>0</b><br>+10 - +1           |
|             | Operator panel function  | Select full or limited operation.  | <b>Full operation</b><br>Limited operation |
|             | Reset inhibit            | Set whether to enable or disable an initial command.   | <b>No</b><br>Yes                           |
|             | Print suppress effective | Set whether to enable or disable a print suppress setup command.   | <b>Yes</b><br>No                           |

| MENU        | ITEM                     | FUNCTION  | SETTING                                |
|-------------|--------------------------|---|--|
| Set-up menu | Auto LF                  | Select whether to perform auto LF operation or not upon receiving a CR code.          | Yes<br><b>No</b>                       |
|             | Auto CR                  | Select whether to perform auto CR operation upon receiving a carriage return command. | Yes<br><b>No</b>                       |
|             | SI select pitch (10 CPI) | Set how to handle an SI command received in 10 CPI mode.                              | 15 CPI<br><b>17.1 CPI</b>              |
|             | SI select Pitch (12 CPI) | Set how to handle an SI command received in 12 CPI mode.                              | <b>12 CPI</b><br>20 CPI                |
|             | Time out print           | Select valid or invalid.  | <b>Valid</b><br>Invalid                |
|             | Printer Style            | Select the printer impact mode.   | Normal<br>Quiet<br>Quick (ML1120 only) |

## INITIALISING MENU SETTINGS

To restore the menu settings to their initial values, carry out the steps below.

---

### *NOTE*

*The values adjusted by the Adjustment menus are not initialised by the following procedure.*

---

- 1.** Set the Power Switch to OFF.
- 2.** Press and hold down the SEL and LF/FF buttons together and then set the Power Switch to ON.

## ADJUSTING TOF POSITION

Use the following procedure to set TOF to accord with the reference position (6.35 mm (0.25 in)). The reference position refers to the first line of the paper i.e. the position to which the printer feeds the paper when automatically loading the paper.

---

### *NOTE*

*Adjusting of TOF can be done in cut sheet mode or continuous forms mode.*

---

- 1.** Print out the menu settings of the printer as in ["Confirming current settings" on page 45](#) and confirm that the TOF (in cut sheet mode or continuous forms mode) is 6.35 mm (0.25 in).
- 2.** Set the Paper Type lever to the required paper type.
- 3.** When continuous forms are used, place the paper on the Pin Tractor.  
  
For cut sheet mode, do not insert the paper at this stage.
- 4.** In continuous forms mode, press the LOAD/EJECT button.  
  
In cut sheet mode, place the paper in the Paper Tray and press LOAD/EJECT.  
  
As the paper is taken into the printer, press the LF/FF button and the paper is taken into the 6.35 mm (0.25 in) position.
- 5.** In off-line mode, press the following buttons to adjust the first printing line:  
  
To feed the paper forward by a small amount, press and hold down the LOAD/EJECT button and then press the SEL button.  
  
To feed the paper backward by a small amount, press and hold down the LOAD/EJECT button and then press the LF/FF button.

---

### *NOTE*

*If the specified correction range is more than +/- 0.366 mm (1/144 in), the QUIET indicator flashes and the paper cannot be moved.*

---



When the paper is positioned at the required TOF, release the buttons in Step 5 above.

To save this position as the TOF, press and hold down the LOAD/EJECT and the LF/FF buttons together for 3 seconds.

---

*NOTE*

*Do not turn the Platen Knob or switch off the printer during the above procedure.*

---

## **PRINTER STYLE (IMPACT MODE) SETTINGS**

The impact mode settings available are Normal, Quiet and Quick (ML1120 only) and the required mode can be set by using the Set-up>Printer Style menu. When switched ON, the printer enters the impact mode selected in this menu.

---

*NOTE*

*In the ML1120, you can cycle through the Normal, Quiet and Quick settings by ensuring that the SEL indicator is illuminated before holding down the SEL button and then pressing the TEAR button repeatedly as required.*

---

# TROUBLESHOOTING

## CLEARING PAPER JAMS

### CUT SHEET PAPER JAMMED IN PRINTER

#### **WARNING!**

**Do not carry out any operations inside the printer with the Power Switch set to ON.**

1. Set the Power Switch to OFF.
2. Remove the Access Cover.

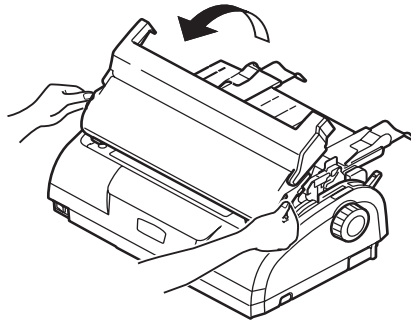

3. Set the Paper Thickness lever to the Replace Ribbon position (position 6).

#### **WARNING!**

**The Print Head may be hot after printing. Allow it to cool before touching it.**

4. Remove the ribbon cartridge. See ["Changing a ribbon cartridge"](#) on page 70.

5. Move the Print Head away from the paper.

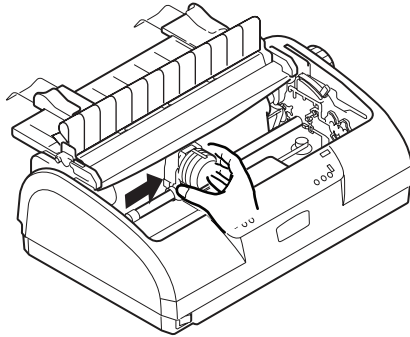

6. Rotate the Platen Knob in the relevant direction and pull the cut sheet out from the top of the printer.
7. If a paper fragment remains inside the printer:
  - (a) use tweezers to grip and extract it or
  - (b) insert a triple folded sheet from the Paper Tray and turn the Platen Knob to pass the folded sheet through and push out the paper fragment.



8. When the paper jams are cleared, replace the ribbon cartridge and replace the printer Access Cover.

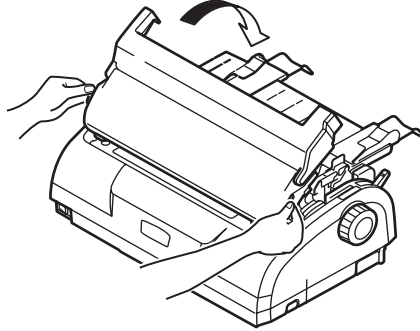

9. Set the Power Switch to ON.

#### CONTINUOUS FORMS JAMMED IN PRINTER

### WARNING!

**Do not carry out any operations inside the printer with the Power Switch set to ON.**

1. Set the Power Switch to OFF.
2. Tear off any unprinted continuous forms.
3. Remove the Input Tray and Rear Cover together by gripping the Input Tray at both sides and pulling it up and away from the printer.

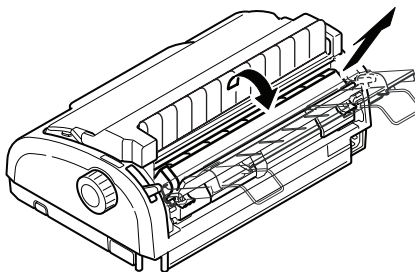

4. Raise each Pin Tractor cover and remove the continuous forms from the Pin Tractors.

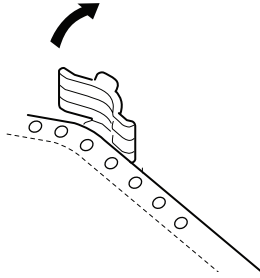

5. Rotate the Platen Knob and remove the forms from the front of the printer.
6. If a form fragment remains inside the printer, place two or three forms in a stack on the Pin Tractors and turn the Platen Knob to push the fragment out of the printer.
7. When the paper jams are cleared, replace the Input Tray and Rear Cover by fitting the Rear Cover into the grooves at the back of the printer and pushing gently forward until the Input Tray clips into place.

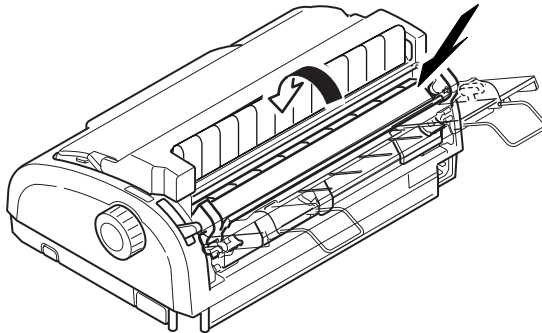

8. Set the Power Switch to ON.

## RESPONDING TO ALARM CONDITIONS

Use the following table for guidance on how to respond to indicated alarm conditions.

| INDICATOR |          | ALARM MEANINGS AND ACTIONS  |
|-----------|----------|---|
| SEL       | ALARM    |   |
| OFF       | ON       | Paper has run out. Add paper and press the SEL button.  |
| OFF       | Flashing | The Paper Type lever is wrongly set for the type of paper in use. Press the SEL button and set the Paper Type lever to the correct position.  |
| OFF       | Flashing | Problem with cut sheet feeding. Remove the cut sheet.   |
| Flashing  | ON       | Print data is received but printing does not start because no paper is being fed. Insert paper.   |
| Flashing  | OFF      | Printing cannot be resumed at this stage. Turn the power OFF, verify that the carriage moves properly, then turn the power ON again.<br><br>If the problem is still there after you turn the power ON again, contact your dealer. |

## RESPONDING TO GENERAL PROBLEMS

Use the following table to help you to identify symptoms with possible causes and take suggested remedial actions.

| PROBLEM         | CAUSE                                      | ACTION  |
|-----------------|--|---|
| <b>No power</b> |  |   |
| No power        | The power cable is not properly connected. | Check the power cable is properly connected at both power outlet and printer. |
|                 | Power outlet problem or power outage.      | Plug another appliance into this outlet to check if it works.                 |

| <b>PROBLEM</b>  | <b>CAUSE</b>   | <b>ACTION</b>  |
|---|--|--|
| <b>No printing takes place</b>                            |  |  |
| SEL indicator is unlit.                                   | The printer driver is not installed properly.  | Re-install the printer driver correctly.   |
|   | The printer has just stopped printing.   | Press the SEL button.  |
|   | There is no paper in the printer.  | Load paper.  |
| SEL indicator is illuminated but no printing takes place. | Interface cable is disconnected.   | Reconnect the interface cable.   |
|   | Wrong interface cable has been used.   | Use correct interface cable.   |
| The print head is moving but no printing takes place.     | The ribbon cartridge has not been installed.   | Install the ribbon cartridge.  |
| <b>Print position offset</b>                              |  |  |
| The horizontal printing position is offset.               | The start position may change after the printer is powered on.                                 | When the printer is powered ON, switch from off-line mode to on-line mode by pressing the SEL button. Reset the start position. You must set the Power Switch to OFF before you change the start position. |
| <b>Printing slows down</b>                                |  |  |
| Print direction changes suddenly to unidirectional.       | When the print head overheats, the printer automatically starts unidirectional split printing. | When the print head temperature drops sufficiently, the printer will return to its original operation.   |
| <b>PE warning</b>   |  |  |
| The print carriage does not operate.                      | There is contamination on the carriage shaft.  | Clean any paper dust and contamination from the carriage with a dry cloth.   |

| <b>PROBLEM</b>  | <b>CAUSE</b>  | <b>ACTION</b>  |
|---|---|--|
| <b>Print blurring</b>   |   |  |
| The characters are too pale to display properly on the paper. | The Paper Thickness lever position does not match the paper.                      | Correct the Paper Thickness lever setting.   |
|   | The printer is set to print at high speed.  | Set the speed to normal.   |
|   | The ribbon has reached its end of life.   | Replace the ribbon by a new one.   |
|   | The ribbon cartridge is not installed correctly.                                  | Reinstall the ribbon cartridge correctly.  |
|   | The ribbon has been wound incorrectly.  | Replace the ribbon cartridge by a new one.   |
|   | The ribbon is not transferring properly.  | Replace the ribbon cartridge by a new one.   |
| A line of print is missing.                                   | Broken wire pins.   | Contact your dealer.   |
| <b>The printout differs from the screen display.</b>          |   |  |
| Printout of completely different characters or symbols.       | Incorrect print setup for the user application.                                   | Reselect print setup for the applications according to priority.                         |
|   | The application control codes for the previous print operation are still enabled. | Initialise the printer.  |
|   | The input application control signal is not correct.                              | Print in hex dump mode and verify the data content. Make corrections in the application. |
|   | The interface cable is not properly connected.                                    | Reconnect the cable correctly.   |



| <b>PROBLEM</b>  | <b>CAUSE</b>   | <b>ACTION</b>   |
|---|--|---|
| Too high or too low TOF (where printing starts).                                      | The TOF is not correctly selected.   | Initialise the printer.   |
|   |  | Select correct TOF for cut sheet and continuous forms.  |
|   |  | Select the first-line print position and adjust the paper top position.   |
|   |  | Reselect the margin correctly in the application.   |
| Too large or small left and/or right margins.   | The left or right margin is not correctly selected.                                    | Incorrect positions of the Paper Guide or Pin Tractors. Select and adjust the position again depending on the paper type. |
|   |  | Reselect the left and right margins correctly in the application.   |
| When continuous forms are used, the content of a single form is printed on two forms. | The paper length selected in the application does not match the physical paper length. | Match the paper length selected in the application with the physical paper length in use.                                 |
| When cut sheets are used, the content of a single sheet is printed on two sheets.     | The paper setting selected in the application does not match the physical paper size.  | Match the paper setting selected in the application with the physical paper in use.                                       |
|   | It does not match the lines per page as the printer automatically detected.            | Leave enough top and bottom margin in the application.  |
|   |  | Correct the cut sheet LF adjustment.  |
| The content of a single line is printed in two lines.                                 | The left and/or right margins are not correctly selected.                              | Reselect the left and right margins correctly in the application.   |
| When continuous forms are used, several blank lines appear in the printout.           | Tear-off perforation spacing is selected.  | Cancel tear-off perforation spacing.  |

| <b>PROBLEM</b>  | <b>CAUSE</b>  | <b>ACTION</b>   |
|---|---|---|
| Broken and uneven vertical lines.   | This may happen in bidirectional printing.  | Use Print Registration in the adjustment mode to adjust.  |
| Too large or small line spacing.  | Line spacing is not selected correctly.   | Reselect line spacing correctly in the application.   |
| <b>Split print</b>  |   |   |
| Blanks appear in graphic printout.  | This is a paper feed error, which is especially notable in printing regular characters. | This is not a failure.  |
| Blanks or deformed characters appear in double height type or other extended types.       | This is a paper feed error due to line feeding in printing a single character.          | This is not a failure.<br>Use the printer's built-in fonts when you print important documents or bills. |
| <b>Improper cut sheet feed</b>  |   |   |
| No paper feed.  | Sheets are located off the paper guide.   | Load sheets with their left edges against the paper guide.  |
|   | Sheets are not loaded to the end.   | Load sheets to the end.   |
| The platen rotates without paper feed, or continuous forms instead of cut sheets are fed. | Sheets are not loaded to the end.   | Load sheets to the end.   |
|   | The printer is in the continuous forms mode.  | Eject the continuous forms and select cut sheet mode for the printer.                                   |
| Paper distortion.   | Sheets are not loaded to the end, or they are not inserted straight.                    | Load sheets to the end.   |
|   | Paper with wrinkles, folds or other defects.  | Change paper.   |
|   | Paper not specified for the printer.  | Use paper types specified for the printer.  |
| Unable to eject.  | The LF/FF button is pressed.  | Press the LOAD/EJECT button.  |

| <b>PROBLEM</b>   | <b>CAUSE</b>   | <b>ACTION</b>   |
|--|--|---|
| <b>Improper continuous forms feed.</b>   |  |   |
| No line feed, and no paper feed.   | Paper is off the Pin Tractors.   | Reload paper correctly.   |
|  | The adjust lever position does not match the paper type.                               | Set the adjust lever to the correct position.   |
| Paper distortion or jam.   | Forms are loaded with their left holes out of line with the right ones.                | Load forms with their left holes in line with the right ones.   |
|  | Inadequate distance between the left and right Pin Tractors, making for loose paper.   | Relocate the Pin Tractors to tighten the paper.   |
|  | Paper movement is blocked.   | Remove the blockage.  |
|  | Paper source is too far from the printer.  | Move the paper source nearer to the printer.  |
|  | Paper not specified for the printer.   | Use paper types specified for this printer.   |
| Several blank lines appear in the printout.  | Skip over perforation spacing is selected.   | Cancel the skip over perforation spacing.   |
| The selected skip over perforation spacing does not match the physical tear-off perforation positions. | The paper length selected in the application does not match the physical paper length. | Match the paper length selected in the application with the physical paper length in use.<br>Select the paper length in number of lines in the application. |
| <b>Abnormal switchover between cut sheet and continuous forms modes.</b>                               |  |   |
| No cut sheet feed.   | The printer is in continuous forms mode.   | Set the Paper Type lever to cut sheet mode.   |
| No continuous forms feed.  | The printer is in cut sheet mode.  | Set the Paper Type lever to continuous forms mode.  |
| Paper feed operations for both cut sheets and continuous forms are actuated.                           | The cut sheet is not ejected.  | Eject the cut sheet.  |

# CLEANING YOUR PRINTER

To keep your printer in good operating condition, you are advised to clean it regularly.

## WARNING!

**Set the printer Power Switch to OFF and disconnect the power cable from the printer before cleaning the printer.**

## PRINTER EXTERIOR

### CAUTION!

**Keep the Access Cover closed to avoid the possibility of detergent entering the printer.**

Clean the exterior of the printer as required, but at least every six months or 300 hours of operation, whichever comes first.

1. Moisten a piece of cotton cloth with diluted neutral detergent and carefully wipe the printer exterior.

## PRINTER INTERIOR

### WARNING!

**As the print head becomes hot during printing, allow it to cool before carrying out any cleaning inside the printer.**

**Do not use any flammable solvents for cleaning the printer to avoid any risk of fire or electric shock.**

Clean the interior of the printer every 6 months or 300 hours of operation, whichever comes first.

Using a soft cloth, cotton swabs and a vacuum cleaner, clean the interior of the printer as follows:

| WHERE TO CLEAN                      | WHAT TO CLEAN   |
|-------------------------------------|---|
| The carriage and the area around it | Clean and remove paper waste, dirt, dust and ribbon shreds. |
| The paper travel surface            |   |

### CAUTION!

**When you clean the interior of the printer with a vacuum cleaner, do not attempt to clean any parts smaller than the suction nozzle.**

**Do not clean any interior working parts with the suction nozzle to avoid possible damage to the printer.**

# CONSUMABLES AND ACCESSORIES

## CONSUMABLES

When the printed image becomes faint or incomplete, replace the ribbon cartridge.

### CHANGING A RIBBON CARTRIDGE

#### CAUTION!

**Only use genuine Oki Original consumables to ensure the best quality and performance from your hardware. Non-Oki Original products may damage your printer's performance and invalidate your warranty.**

#### WARNING!

**Do not change the ribbon cartridge with the Power Switch set to ON.**

1. Set the Power Switch to OFF.
2. Set the Paper Thickness lever to Replace Ribbon (position 6).
3. Remove the Access Cover.

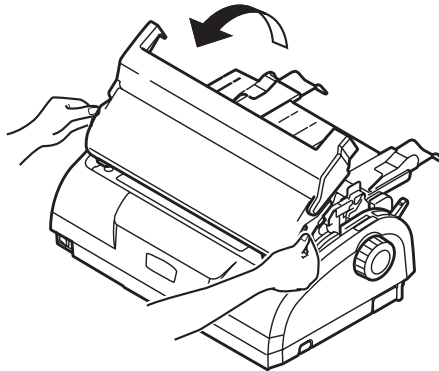

## WARNING!

**The print head and area around it may be hot after printing. Allow it to cool down before touching it.**

4. Grip the ribbon cartridge with your fingers at each end and slope it up and out to remove it from the carriage.

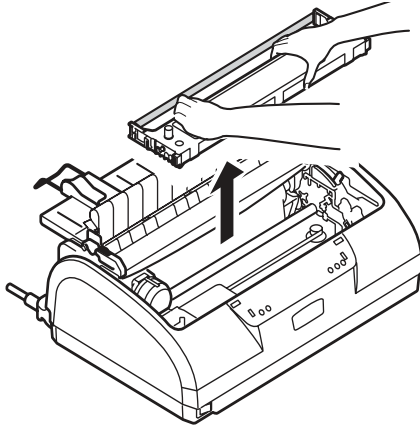

5. Dispose of the cartridge in accordance with your local guidelines.
6. Remove the new ribbon cartridge from its wrapping and note the position of the Ribbon Guide (1), blue Knob (2) and Pin (3).

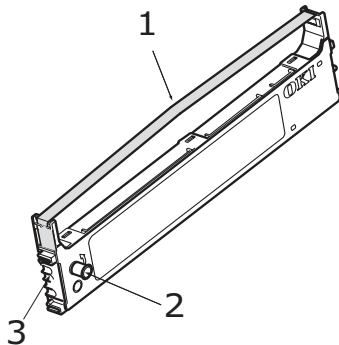

7. In the direction indicated by the arrows, insert the pins at both ends of the ribbon cartridge into the U grooves in the printer until the ribbon cartridge is fully locked.

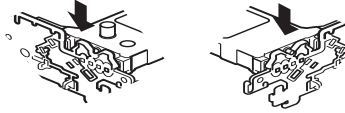

---

**NOTE**

*It may be easier to mount the ribbon cartridge in place if you align it with the topside of the grooves. Also, a slightly loose ribbon may make it easier to mount the ribbon cartridge.*

---

8. Hold the ribbon cartridge with your fingers pressing on its ribbon guide and slope it upward and inward along the guide rails until the ribbon guide comes in line with the U slot at the top of the cartridge.
9. Move the print head to position the ribbon then turn the knob anticlockwise (in the direction of the arrow) to wind up the ribbon.

**CAUTION!**

**Do not turn the knob clockwise as the ribbon might jam.**

**Make sure that the ribbon is not twisted or damaged when it goes through the gap between the Print Head and the ribbon guide.**

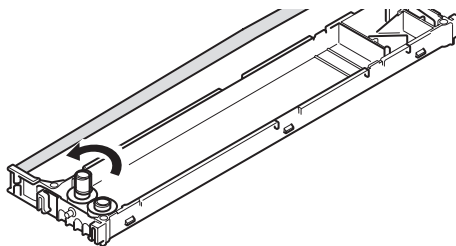



10. Replace the Access Cover.

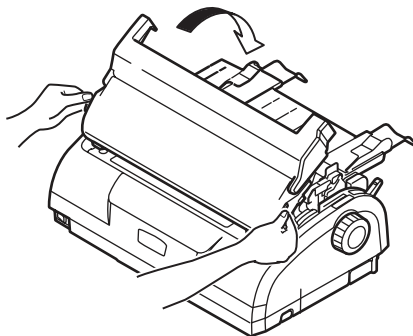

11. Set the Paper Thickness lever to match the paper being used. (See ["Setting the Paper Thickness lever" on page 38.](#))
12. Set the printer Power Switch to ON.

#### CONSUMABLE ORDER INFORMATION

| ITEM                     | LIFE                 | ORDER NO.                           |
|--------------------------|----------------------|-------------------------------------|
| Ribbon cartridge (Black) | 4 million characters | 43571082 (EU)<br>43571803 (Non- EU) |

# SPECIFICATIONS

## ML1120

| ITEM  | SPECIFICATION  |
|---|--|
| Product Name  | ML1120   |
| Model No.   | D22400B  |
| Print method  | Impact dot matrix  |
| Print head  | 9 pins, 0.2 mm (0.0079 in) diameter  |
| Print direction   | Bi-directional, short-line-seeking printing  |
| Print speed<br>High Speed Draft (HSD)<br>Letter Quality (LQ)<br>Utility | 400cps @ 10 cpi<br>100 cps @ 10 cpi<br>300 cps @ 10 cpi  |
| Line Feed (LF) time   | Approximately 47 ms per line for LF of 4.23 mm (1/6 in)  |
| Form Feed (FF) speed  | Approximately 114.3 mm/s (4.5 in/s)  |
| Paper feed control  | Paper feed: yes<br>Vertical tab: yes<br>Direct line feed: yes  |
| Duplication capability  | Continuous forms: the original page +4 more pages (total maximum paper thickness less than 0.325 mm)<br><br>Cut sheet: the original page +4 more pages (total maximum paper thickness less than 0.325 mm)                              |
| Feeding direction   | Feed forward<br>Feed backward<br>Feed upward   |
| Feeding mode  | Friction feed mode (top)<br>Pin tractor feed mode (rear)<br>Pin tractor feed mode (bottom)   |
| Continuous forms tape tail detection method                             | Detected when remaining paper is approximately 46 mm long. It can, however, print till about 6 mm from the paper bottom (measured at the centre of the characters).<br><br>(The print accuracy of the last page cannot be guaranteed.) |

| ITEM   | SPECIFICATION  |
|--|--|
| Character sets   | Standard ASCII<br>Epson (Italics/Graphics)<br>IBM (Set1/Set2)<br>ML<br>Foreign<br>Code Page  |
| Media  | <a href="#">See "Setting the Paper Thickness lever" on page 38.</a>  |
| Original OKI cartridge ribbon<br>Ink color<br>Ribbon life        | Black<br>4 million characters (Utility mode)   |
| Print head life  | 200 million characters   |
| Dimensions   | 349 mm (W) x 150 mm (H) x 232 mm (D)<br>with platen knob installed   |
| Weight   | Approximately 4.2 kg   |
| Power rating<br>Voltage<br>Frequency                             | 220 – 240V ± 10%<br>50/60 Hz ± 1 Hz  |
| Power consumption<br>Operation<br>Standby mode<br>Powersave mode | Typ. 41 W<br>15 W<br>6 W   |
| Power cable  | 3 - core AC power cable, approximately<br>1.8 m length   |
| Interfaces   | Bi-directional parallel, IEEE1284-1994<br>USB 2.0<br>RS-232C   |
| Dust and corrosion   | Use the printer in a general office<br>environment.  |
| Environmental conditions<br>Operating<br><br>Storage             | 5°C – 35°C, 30% – 85% RH (Testing<br>condition for print precision: 15°C – 30°C,<br>40% – 70%RH)<br><br>-20°C – 60°C, 5% – 95% RH<br><br>When the printer is stored, it should be in its<br>original packaging, with no moisture<br>formation. |
| Standard usage<br>Average power on time<br>Average printing time | 200 h/month<br>50 h/month (text density on page: 35%)  |

| ITEM        | SPECIFICATION   |
|-------------|---|
| Noise level | The acoustic noise of this product is less than 70 dB (A) as measured in accordance with EN ISO 7779. |

# ML1190

| ITEM  | SPECIFICATION  |
|---|--|
| Product Name  | ML1190   |
| Model No.   | D22410B  |
| Print method  | Impact dot matrix  |
| Print head  | 24 pins, 0.2 mm (0.0079 in) diameter   |
| Print direction   | Bi-directional, short-line-seeking printing  |
| Print speed<br>High Speed Draft (HSD)<br>Letter Quality (LQ)<br>Utility | 400cps @ 10 cpi<br>100 cps @ 10 cpi<br>300 cps @ 10 cpi  |
| Line Feed (LF) time   | Approximately 47 ms per line for LF of 4.23 mm (1/6 in)  |
| Form Feed (FF) speed  | Approximately 114.3 mm/s (4.5 in/s)  |
| Paper feed control  | Paper feed: yes<br>Vertical tab: yes<br>Direct line feed: yes  |
| Duplication capability  | Continuous forms: the original page +4 more pages (total maximum paper thickness less than 0.325 mm)<br><br>Cut sheet: the original page +4 more pages (total maximum paper thickness less than 0.325 mm)                          |
| Feeding direction   | Feed forward<br>Feed backward<br>Feed upward   |
| Feeding mode  | Friction feed mode (top)<br>Pin tractor feed mode (rear)<br>Pin tractor feed mode (bottom)   |
| Continuous forms tape tail detection method                             | Detected when remaining paper is approximately 46 mm long. It can, however, print till about 6 mm from the paper bottom (measured at the centre of the characters).<br>(The print accuracy of the last page cannot be guaranteed.) |

| ITEM   | SPECIFICATION  |
|--|--|
| Character sets   | Standard ASCII<br>Epson (Italics/Graphics)<br>IBM (Set1/Set2)<br>ML<br>Foreign<br>Code Page  |
| Media  | <a href="#">See "Setting the Paper Thickness lever" on page 38.</a>  |
| Original OKI cartridge ribbon<br>Ink color<br>Ribbon life        | Black<br>4 million characters (Utility mode)   |
| Print head life  | 200 million characters   |
| Dimensions   | 349 mm (W) x 150 mm (H) x 232 mm (D)<br>with platen knob installed   |
| Weight   | Approximately 4.2 kg   |
| Power rating<br>Voltage<br>Frequency                             | 220 – 240V ± 10%<br>50/60 Hz ± 1 Hz  |
| Power consumption<br>Operation<br>Standby mode<br>Powersave mode | Typ. 41 W<br>15 W<br>6 W   |
| Power cable  | 3 - core AC power cable, approximately<br>1.8 m length   |
| Interfaces   | Bi-directional parallel, IEEE1284-1994<br>USB 2.0<br>RS-232C   |
| Dust and corrosion   | Use the printer in a general office<br>environment.  |
| Environmental conditions<br>Operating<br><br>Storage             | 5°C – 35°C, 30% – 85% RH (Testing<br>condition for print precision: 15°C – 30°C,<br>40% – 70%RH)<br><br>-20°C – 60°C, 5% – 95% RH<br><br>When the printer is stored, it should be in its<br>original packaging, with no moisture<br>formation. |
| Standard usage<br>Average power on time<br>Average printing time | 200 h/month<br>50 h/month (text density on page: 35%)  |

| ITEM        | SPECIFICATION   |
|-------------|---|
| Noise level | The acoustic noise of this product is less than 70 dB (A) as measured in accordance with EN ISO 7779. |

# INDEX

## A

- alarm indications ..... 62
- aligning perforations ..... 35

## B

- buttons ..... 44

## C

- cleaning
  - exterior ..... 68
  - interior ..... 68

## D

- drivers ..... 16

## E

- ejecting paper
  - continuous forms ..... 35
  - cut sheet ..... 20

## F

- fault finding ..... 62

## I

- indicators ..... 41
- interface
  - parallel ..... 15
  - serial ..... 15
  - USB ..... 15

## L

- loading paper
  - continuous forms ..... 21
  - cut sheet ..... 18

## M

- menu settings
  - changing ..... 46
  - confirming ..... 45
  - initialising ..... 55
  - list ..... 47

## P

- paper jams
  - continuous forms ..... 60
  - cut sheet ..... 58
- printer
  - control panel ..... 40
  - location ..... 12
  - parts ..... 9
  - test print ..... 13
- printing files ..... 17

## R

- ribbon
  - changing ..... 70
  - ordering ..... 73

## S

- setting paper thickness ..... 38
- specifications ..... 74
- switching ON ..... 12

## T

- test page ..... 16
- TOF
  - saving ..... 57
  - setting ..... 56

## U

- user guide
  - list ..... 6
  - printing ..... 7



# OKI PRINTING SOLUTIONS CONTACT DETAILS

## **Oki Systems (UK) Limited**

550 Dundee Road  
Slough Trading Estate  
Slough, SL1 4LE

Tel:44 (0) 1753 819819  
Fax:44 (0) 1753 819899  
<http://www.oki.co.uk>

## **Oki Systems Ireland Limited**

The Square Industrial Complex  
Tallaght, Dublin 24, Ireland

Tel:+353 1 4049590  
Fax:+353 1 4049591  
<http://www.oki.ie>

Technical Support:

Tel:+353 1 4049570  
Fax:+353 1 4049555  
E-mail: [tech.support@oki.ie](mailto:tech.support@oki.ie)

## **OKI Systems (Ireland) Ltd.**

(Northern Ireland)  
40 Sydenham Park  
Belfast, BT4 1PW

Tel:+44 (0)28 90 20 1110  
<http://www.oki.ie>

Technical Support:

Tel: +44 (0)28 90 221919  
E-mail: [tech.support@oki.ie](mailto:tech.support@oki.ie)

## **Oki Data Corporation**

4-11-22 Shibaura, Minato-ku, Tokyo  
108-8551, Japan

Tel:(81) 3 5445 6158  
Fax:(81) 3 5445 6189  
<http://www.okidata.co.jp>

## **Oki Data (Singapore) Pte. Ltd.**

78 Shenton Way, #09-01,  
Singapore 079120

Tel:(65) 221 3722  
Fax:(65)421 1688  
<http://www.okidata.com.sg>

## **Oki Systems (Thailand) Ltd.**

956 Udomvidhya Building 6th Floor,  
Rama IV Rd., Bangkok 10500, Thailand

Tel:(662) 636 2535  
Fax:(662) 636 2536  
<http://www.okisysthai.com>

## **Oki Hong Kong Limited**

Suite 1909, Tower3,  
China Hong Kong City,  
33 Canton Rd., Tsimshatsui,  
Kowloon, Hong Kong

Tel:(852) 2736 0130  
Fax:(852) 2376 3725

## **The IPL Group**

63-85 Victoria Street  
Beaconsfield NSW 2015, Australia

Tel:(61) 2 9690 8200  
Fax:(61) 2 9690 8300  
<http://www.oki.com.au>

## **Comworth Systems Ltd.**

10 Constellation Drive Mairangi Bay,  
Auckland,  
New Zealand

Tel:(64) 9 477 0500  
Fax:(64) 9 477 0549  
<http://www.comworth.co.nz>

**OKI EUROPE LIMITED**

Central House

Balfour Road

Hounslow TW3 1HY

United Kingdom

Tel: +44 (0) 208 219 2190

Fax: +44 (0) 208 219 2199

**WWW.OKIPRINTINGSOLUTIONS.COM**

