

# GS-2024

*Layer 2 Ethernet Switch*

## ***User's Guide***

Version 3.80  
06/2008  
Edition 1

### **DEFAULT LOGIN**

<b>IP Address</b>	<b>http://192.168.0.1 (Out-of-band MGMT port)</b> <b>http://192.168.1.1 (In-band ports)</b>
<b>User Name</b>	<b>admin</b>
<b>Password</b>	<b>1234</b>

---

**ZyXEL**  
[www.zyxel.com](http://www.zyxel.com)



# About This User's Guide

## Intended Audience

This manual is intended for people who want to configure the Switch using the web configurator or via commands. You should have at least a basic knowledge of TCP/IP networking concepts and topology.

## Related Documentation

- Web Configurator Online Help  
Embedded web help for descriptions of individual screens and supplementary information.



---

It is recommended you use the web configurator to configure the Switch.

---

- Supporting Disc  
Refer to the included CD for support documents.
- ZyXEL Web Site  
Please refer to [www.zyxel.com](http://www.zyxel.com) for additional support documentation and product certifications.

## User Guide Feedback

Help us help you. Send all User Guide-related comments, questions or suggestions for improvement to the following address, or use e-mail instead. Thank you!

The Technical Writing Team,  
ZyXEL Communications Corp.,  
6 Innovation Road II,  
Science-Based Industrial Park,  
Hsinchu, 300, Taiwan.

E-mail: [techwriters@zyxel.com.tw](mailto:techwriters@zyxel.com.tw)

## Disclaimer

Graphics in this book may differ slightly from the product due to differences in operating systems, operating system versions, or if you installed updated firmware/software for your device. Every effort has been made to ensure that the information in this manual is accurate.

# Document Conventions

## Warnings and Notes

These are how warnings and notes are shown in this User's Guide.



---

Warnings tell you about things that could harm you or your device.

---



---

Notes tell you other important information (for example, other things you may need to configure or helpful tips) or recommendations.









---

## Syntax Conventions

- The XGS-4528F may be referred to as the “Switch”, the “device”, the “system” or the “product” in this User's Guide.
- Product labels, screen names, field labels and field choices are all in **bold** font.
- A key stroke is denoted by square brackets and uppercase text, for example, [ENTER] means the “enter” or “return” key on your keyboard.
- “Enter” means for you to type one or more characters and then press the [ENTER] key. “Select” or “choose” means for you to use one of the predefined choices.
- A right angle bracket ( > ) within a screen name denotes a mouse click. For example, **Maintenance > Log > Log Setting** means you first click **Maintenance** in the navigation panel, then the **Log** sub menu and finally the **Log Setting** tab to get to that screen.
- Units of measurement may denote the “metric” value or the “scientific” value. For example, “k” for kilo may denote “1000” or “1024”, “M” for mega may denote “1000000” or “1048576” and so on.

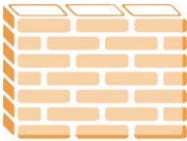
## Icons Used in Figures

Figures in this User's Guide may use the following generic icons. The Switch icon is not an exact representation of your device.

The Switch 	Computer 	Notebook computer 
Server 	DSLAM 	Firewall 
Telephone 	Switch 	Router 

# Safety Warnings



---

For your safety, be sure to read and follow all warning notices and instructions.

---

- Do NOT use this product near water, for example, in a wet basement or near a swimming pool.
- Do NOT expose your device to dampness, dust or corrosive liquids.
- Do NOT store things on the device.
- Do NOT install, use, or service this device during a thunderstorm. There is a remote risk of electric shock from lightning.
- Connect ONLY suitable accessories to the device.
- Do NOT open the device or unit. Opening or removing covers can expose you to dangerous high voltage points or other risks. ONLY qualified service personnel should service or disassemble this device. Please contact your vendor for further information.
- Make sure to connect the cables to the correct ports.
- Place connecting cables carefully so that no one will step on them or stumble over them.
- Always disconnect all cables from this device before servicing or disassembling.
- Use ONLY an appropriate power adaptor or cord for your device. Connect it to the right supply voltage (for example, 110V AC in North America or 230V AC in Europe).
- Do NOT allow anything to rest on the power adaptor or cord and do NOT place the product where anyone can walk on the power adaptor or cord.
- Do NOT use the device if the power adaptor or cord is damaged as it might cause electrocution.
- If the power adaptor or cord is damaged, remove it from the device and the power source.
- Do NOT attempt to repair the power adaptor or cord. Contact your local vendor to order a new one.
- Do not use the device outside, and make sure all the connections are indoors. There is a remote risk of electric shock from lightning.
- Do NOT obstruct the device ventilation slots, as insufficient airflow may harm your device.

This product is recyclable. Dispose of it properly.

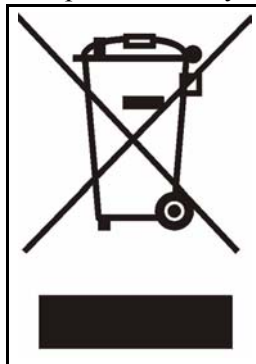





# Contents Overview

<b>Introduction .....</b>	<b>27</b>
Getting to Know Your Switch .....	29
Hardware Installation and Connection .....	33
Hardware Overview .....	37
<b>Basic Configuration .....</b>	<b>43</b>
The Web Configurator .....	45
Initial Setup Example .....	53
System Status and Port Statistics .....	57
Basic Setting .....	63
<b>Advanced Setup .....</b>	<b>75</b>
VLAN .....	77
Static MAC Forward Setup .....	89
Spanning Tree Protocol .....	91
Bandwidth Control .....	105
Broadcast Storm Control .....	107
Mirroring .....	109
Link Aggregation .....	111
Port Authentication .....	117
Port Security .....	121
Queuing Method .....	123
Multicast .....	125
Authentication & Accounting .....	139
Loop Guard .....	153
<b>IP Application .....</b>	<b>157</b>
Static Route .....	159
Differentiated Services .....	163
DHCP .....	167
<b>Management .....</b>	<b>173</b>
Maintenance .....	175
Access Control .....	181
Diagnostic .....	199
Syslog .....	201
Cluster Management .....	205

MAC Table .....211  
ARP Table ..... 213  
Configure Clone ..... 215

**Troubleshooting & Product Specifications ..... 217**

    Troubleshooting ..... 219  
    Product Specifications ..... 223

**Appendices and Index ..... 231**

# Table of Contents

<b>About This User's Guide .....</b>	<b>3</b>
<b>Document Conventions.....</b>	<b>4</b>
<b>Safety Warnings.....</b>	<b>6</b>
<b>Contents Overview .....</b>	<b>9</b>
<b>Table of Contents.....</b>	<b>11</b>
<b>List of Figures .....</b>	<b>19</b>
<b>List of Tables.....</b>	<b>23</b>
<b>Part I: Introduction.....</b>	<b>27</b>
<b>Chapter 1</b>	
<b>Getting to Know Your Switch.....</b>	<b>29</b>
1.1 Introduction .....	29
1.1.1 Backbone Application .....	29
1.1.2 Bridging Example .....	30
1.1.3 High Performance Switching Example .....	30
1.1.4 IEEE 802.1Q VLAN Application Examples .....	31
1.2 Ways to Manage the Switch .....	31
1.3 Good Habits for Managing the Switch .....	32
<b>Chapter 2</b>	
<b>Hardware Installation and Connection .....</b>	<b>33</b>
2.1 Freestanding Installation .....	33
2.2 Mounting the Switch on a Rack .....	34
2.2.1 Rack-mounted Installation Requirements .....	34
2.2.2 Attaching the Mounting Brackets to the Switch .....	34
2.2.3 Mounting the Switch on a Rack .....	35
<b>Chapter 3</b>	
<b>Hardware Overview.....</b>	<b>37</b>
3.1 Front Panel Connections .....	37
3.1.1 1000Base-T Ports .....	38
3.1.2 Dual Personality Interfaces .....	38

3.1.3 Console Port .....	40
3.1.4 Management Port .....	40
3.2 Rear Panel .....	40
3.2.1 Power Connector .....	41
3.3 LEDs .....	41
<b>Part II: Basic Configuration.....</b>	<b>43</b>
<b>Chapter 4</b>	
<b>The Web Configurator .....</b>	<b>45</b>
4.1 Introduction .....	45
4.2 System Login .....	45
4.3 The Status Screen .....	46
4.3.1 Change Your Password .....	50
4.4 Saving Your Configuration .....	50
4.5 Switch Lockout .....	51
4.6 Resetting the Switch .....	51
4.6.1 Reload the Configuration File .....	51
4.7 Logging Out of the Web Configurator .....	52
4.8 Help .....	52
<b>Chapter 5</b>	
<b>Initial Setup Example.....</b>	<b>53</b>
5.1 Overview .....	53
5.1.1 Creating a VLAN .....	53
5.1.2 Setting Port VID .....	54
5.1.3 Configuring Switch Management IP Address .....	55
<b>Chapter 6</b>	
<b>System Status and Port Statistics.....</b>	<b>57</b>
6.1 Overview .....	57
6.2 Port Status Summary .....	57
6.2.1 Status: Port Details .....	58
<b>Chapter 7</b>	
<b>Basic Setting .....</b>	<b>63</b>
7.1 Overview .....	63
7.2 System Information .....	63
7.3 General Setup .....	65
7.4 Introduction to VLANs .....	67
7.5 Switch Setup Screen .....	67

7.6 IP Setup .....	69
7.6.1 IP Interfaces .....	69
7.7 Port Setup .....	72
<b>Part III: Advanced Setup.....</b>	<b>75</b>
<b>Chapter 8</b>	
<b>VLAN .....</b>	<b>77</b>
8.1 Introduction to IEEE 802.1Q Tagged VLANs .....	77
8.1.1 Forwarding Tagged and Untagged Frames .....	77
8.2 Automatic VLAN Registration .....	78
8.2.1 GARP .....	78
8.2.2 GVRP .....	78
8.3 Port VLAN Trunking .....	79
8.4 Select the VLAN Type .....	79
8.5 Static VLAN .....	79
8.5.1 Static VLAN Status .....	80
8.5.2 Static VLAN Details .....	80
8.5.3 Configure a Static VLAN .....	81
8.5.4 Configure VLAN Port Settings .....	82
8.6 Port-based VLAN Setup .....	84
8.6.1 Configure a Port-based VLAN .....	84
<b>Chapter 9</b>	
<b>Static MAC Forward Setup.....</b>	<b>89</b>
9.1 Overview .....	89
9.2 Configuring Static MAC Forwarding .....	89
<b>Chapter 10</b>	
<b>Spanning Tree Protocol.....</b>	<b>91</b>
10.1 STP/RSTP Overview .....	91
10.1.1 STP Terminology .....	91
10.1.2 How STP Works .....	92
10.1.3 STP Port States .....	92
10.1.4 Multiple STP .....	93
10.2 Spanning Tree Protocol Status Screen .....	95
10.3 Spanning Tree Configuration .....	96
10.4 Configure Rapid Spanning Tree Protocol .....	96
10.5 Rapid Spanning Tree Protocol Status .....	98
10.6 Configure Multiple Spanning Tree Protocol .....	99
10.7 Multiple Spanning Tree Protocol Status .....	102

<b>Chapter 11</b>	
<b>Bandwidth Control</b> .....	<b>105</b>
11.1 Bandwidth Control Overview .....	105
11.2 Bandwidth Control Setup .....	105
<b>Chapter 12</b>	
<b>Broadcast Storm Control</b> .....	<b>107</b>
12.1 Broadcast Storm Control Setup .....	107
<b>Chapter 13</b>	
<b>Mirroring</b> .....	<b>109</b>
13.1 Port Mirroring Setup .....	109
<b>Chapter 14</b>	
<b>Link Aggregation</b> .....	<b>111</b>
14.1 Link Aggregation Overview .....	111
14.2 Dynamic Link Aggregation .....	111
14.2.1 Link Aggregation ID .....	112
14.3 Link Aggregation Status .....	112
14.4 Link Aggregation Setting .....	113
14.5 Link Aggregation Control Protocol .....	114
14.6 Static Trunking Example .....	115
<b>Chapter 15</b>	
<b>Port Authentication</b> .....	<b>117</b>
15.1 Port Authentication Overview .....	117
15.1.1 IEEE 802.1x Authentication .....	117
15.2 Port Authentication Configuration .....	118
15.2.1 Activate IEEE 802.1x Security .....	118
<b>Chapter 16</b>	
<b>Port Security</b> .....	<b>121</b>
16.1 About Port Security .....	121
16.2 Port Security Setup .....	121
<b>Chapter 17</b>	
<b>Queuing Method</b> .....	<b>123</b>
17.1 Queuing Method Overview .....	123
17.1.1 Strictly Priority .....	123
17.1.2 Weighted Round Robin Scheduling (WRR) .....	123
17.2 Configuring Queuing .....	124

<b>Chapter 18</b>	
<b>Multicast</b> .....	<b>125</b>
18.1 Multicast Overview .....	125
18.1.1 IP Multicast Addresses .....	125
18.1.2 IGMP Filtering .....	125
18.1.3 IGMP Snooping .....	125
18.1.4 IGMP Snooping and VLANs .....	126
18.2 Multicast Status .....	126
18.3 Multicast Setting .....	126
18.4 IGMP Snooping VLAN .....	128
18.5 IGMP Filtering Profile .....	130
18.6 MVR Overview .....	131
18.6.1 Types of MVR Ports .....	131
18.6.2 MVR Modes .....	132
18.6.3 How MVR Works .....	132
18.7 General MVR Configuration .....	132
18.8 MVR Group Configuration .....	134
18.8.1 MVR Configuration Example .....	135
<b>Chapter 19</b>	
<b>Authentication &amp; Accounting</b> .....	<b>139</b>
19.1 Authentication, Authorization and Accounting .....	139
19.1.1 Local User Accounts .....	139
19.1.2 RADIUS and TACACS+ .....	140
19.2 Authentication and Accounting Screens .....	140
19.2.1 RADIUS Server Setup .....	140
19.2.2 TACACS+ Server Setup .....	142
19.2.3 Authentication and Accounting Setup .....	144
19.2.4 Vendor Specific Attribute .....	147
19.2.5 Tunnel Protocol Attribute .....	148
19.3 Supported RADIUS Attributes .....	148
19.3.1 Attributes Used for Authentication .....	149
19.3.2 Attributes Used for Accounting .....	149
<b>Chapter 20</b>	
<b>Loop Guard</b> .....	<b>153</b>
20.1 Loop Guard Overview .....	153
20.2 Loop Guard Setup .....	155
<b>Part IV: IP Application</b> .....	<b>157</b>

<b>Chapter 21</b>	
<b>Static Route</b> .....	<b>159</b>
21.1 Static Routing Overview .....	159
21.2 Configuring Static Routing .....	159
<b>Chapter 22</b>	
<b>Differentiated Services</b> .....	<b>163</b>
22.1 DiffServ Overview .....	163
22.1.1 DSCP and Per-Hop Behavior .....	163
22.1.2 DiffServ Network Example .....	164
22.2 DSCP-to-IEEE 802.1p Priority Settings .....	164
22.3 Activating DiffServ .....	164
<b>Chapter 23</b>	
<b>DHCP</b> .....	<b>167</b>
23.1 DHCP Overview .....	167
23.1.1 DHCP Modes .....	167
23.1.2 DHCP Configuration Options .....	167
23.2 DHCP Status .....	167
23.3 DHCP Relay .....	168
23.3.1 DHCP Relay Agent Information .....	168
23.3.2 Configuring DHCP Global Relay .....	169
23.3.3 Global DHCP Relay Configuration Example .....	170
23.4 Configuring DHCP VLAN Settings .....	170
23.4.1 Example: DHCP Relay for Two VLANs .....	172
<b>Part V: Management</b> .....	<b>173</b>
<b>Chapter 24</b>	
<b>Maintenance</b> .....	<b>175</b>
24.1 The Maintenance Screen .....	175
24.2 Load Factory Default .....	176
24.3 Save Configuration .....	176
24.4 Reboot System .....	177
24.5 Firmware Upgrade .....	177
24.6 Restore a Configuration File .....	178
24.7 Backup a Configuration File .....	178
24.8 FTP Command Line .....	179
24.8.1 Filename Conventions .....	179
24.8.2 FTP Command Line Procedure .....	179
24.8.3 GUI-based FTP Clients .....	180



24.8.4 FTP Restrictions .....	180
<b>Chapter 25</b>	
<b>Access Control.....</b>	<b>181</b>
25.1 Access Control Overview .....	181
25.2 The Access Control Main Screen .....	181
25.3 About SNMP .....	182
25.3.1 SNMP v3 and Security .....	183
25.3.2 Supported MIBs .....	183
25.3.3 SNMP Traps .....	183
25.3.4 Configuring SNMP .....	186
25.3.5 Configuring SNMP Trap Group .....	188
25.3.6 Setting Up Login Accounts .....	189
25.4 SSH Overview .....	191
25.5 How SSH works .....	191
25.6 SSH Implementation on the Switch .....	192
25.6.1 Requirements for Using SSH .....	192
25.7 Introduction to HTTPS .....	192
25.8 HTTPS Example .....	193
25.8.1 Internet Explorer Warning Messages .....	193
25.8.2 Netscape Navigator Warning Messages .....	194
25.8.3 The Main Screen .....	194
25.9 Service Port Access Control .....	195
25.10 Remote Management .....	196
<b>Chapter 26</b>	
<b>Diagnostic.....</b>	<b>199</b>
26.1 Diagnostic .....	199
<b>Chapter 27</b>	
<b>Syslog .....</b>	<b>201</b>
27.1 Syslog Overview .....	201
27.2 Syslog Setup .....	201
27.3 Syslog Server Setup .....	202
<b>Chapter 28</b>	
<b>Cluster Management.....</b>	<b>205</b>
28.1 Clustering Management Status Overview .....	205
28.2 Cluster Management Status .....	206
28.2.1 Cluster Member Switch Management .....	207
28.3 Clustering Management Configuration .....	208
<b>Chapter 29</b>	
<b>MAC Table.....</b>	<b>211</b>

29.1 MAC Table Overview .....	211
29.2 Viewing the MAC Table .....	212
<b>Chapter 30</b>	
<b>ARP Table .....</b>	<b>213</b>
30.1 ARP Table Overview .....	213
30.1.1 How ARP Works .....	213
30.2 Viewing the ARP Table .....	213
<b>Chapter 31</b>	
<b>Configure Clone .....</b>	<b>215</b>
31.1 Configure Clone .....	215
<b>Part VI: Troubleshooting &amp; Product Specifications.....</b>	<b>217</b>
<b>Chapter 32</b>	
<b>Troubleshooting.....</b>	<b>219</b>
32.1 Power, Hardware Connections, and LEDs .....	219
32.2 Switch Access and Login .....	220
<b>Chapter 33</b>	
<b>Product Specifications .....</b>	<b>223</b>
<b>Part VII: Appendices and Index .....</b>	<b>231</b>
Appendix A Pop-up Windows, JavaScripts and Java Permissions .....	233
Appendix B IP Addresses and Subnetting .....	241
Appendix C Legal Information .....	249
Appendix D Customer Support.....	253
<b>Index.....</b>	<b>259</b>

# List of Figures

Figure 1 Backbone Application .....	29
Figure 2 Bridging Application .....	30
Figure 3 High Performance Switched Workgroup Application .....	30
Figure 4 Shared Server Using VLAN Example .....	31
Figure 5 Attaching Rubber Feet .....	33
Figure 6 Attaching the Mounting Brackets .....	34
Figure 7 Mounting the Switch on a Rack .....	35
Figure 8 Front Panel .....	37
Figure 9 Transceiver Installation Example .....	39
Figure 10 Installed Transceiver .....	39
Figure 11 Opening the Transceiver's Latch Example .....	40
Figure 12 Transceiver Removal Example .....	40
Figure 13 Rear Panel .....	41
Figure 14 Web Configurator: Login .....	46
Figure 15 Web Configurator Home Screen (Status) .....	46
Figure 16 Change Administrator Login Password .....	50
Figure 17 Resetting the Switch: Via the Console Port .....	52
Figure 18 Web Configurator: Logout Screen .....	52
Figure 19 Initial Setup Network Example: VLAN .....	53
Figure 20 Initial Setup Network Example: Port VID .....	54
Figure 21 Initial Setup Example: Management IP Address .....	55
Figure 22 Status .....	57
Figure 23 Status: Port Details .....	59
Figure 24 Basic Setting > System Info .....	64
Figure 25 Basic Setting > General Setup .....	65
Figure 26 Basic Setting > Switch Setup .....	68
Figure 27 Basic Setting > IP Setup .....	70
Figure 28 Basic Setting > Port Setup .....	72
Figure 29 Port VLAN Trunking .....	79
Figure 30 Switch Setup: Select VLAN Type .....	79
Figure 31 Advanced Application > VLAN: VLAN Status .....	80
Figure 32 Advanced Application > VLAN > VLAN Detail .....	80
Figure 33 Advanced Application > VLAN > Static VLAN .....	81
Figure 34 Advanced Application > VLAN > VLAN Port Setting .....	83
Figure 35 Advanced Application > VLAN > Port Based VLAN Setup (All Connected) .....	85
Figure 36 Advanced Application > VLAN: Port Based VLAN Setup (Port Isolation) .....	86
Figure 37 Advanced Application > Static MAC Forwarding .....	89
Figure 38 STP/RSTP Network Example .....	93

Figure 39 MSTP Network Example .....	94
Figure 40 MSTIs in Different Regions .....	95
Figure 41 MSTP and Legacy RSTP Network Example .....	95
Figure 42 Advanced Application > Spanning Tree Protocol .....	96
Figure 43 Advanced Application > Spanning Tree Protocol > Configuration .....	96
Figure 44 Advanced Application > Spanning Tree Protocol > RSTP .....	97
Figure 45 Advanced Application > Spanning Tree Protocol > Status: RSTP .....	99
Figure 46 Advanced Application > Spanning Tree Protocol > MSTP .....	100
Figure 47 Advanced Application > Spanning Tree Protocol > Status: MSTP .....	103
Figure 48 Advanced Application > Bandwidth Control .....	105
Figure 49 Advanced Application > Broadcast Storm Control .....	107
Figure 50 Advanced Application > Mirroring .....	109
Figure 51 Advanced Application > Link Aggregation Status .....	112
Figure 52 Advanced Application > Link Aggregation > Link Aggregation Setting .....	113
Figure 53 Advanced Application > Link Aggregation > Link Aggregation Setting > LACP .....	114
Figure 54 Trunking Example - Physical Connections .....	116
Figure 55 Trunking Example - Configuration Screen .....	116
Figure 56 IEEE 802.1x Authentication Process .....	118
Figure 57 Advanced Application > Port Authentication .....	118
Figure 58 Advanced Application > Port Authentication > 802.1x .....	119
Figure 59 Advanced Application > Port Security .....	122
Figure 60 Advanced Application > Queuing Method .....	124
Figure 61 Advanced Application > Multicast .....	126
Figure 62 Advanced Application > Multicast > Multicast Setting .....	127
Figure 63 Advanced Application > Multicast > Multicast Setting > IGMP Snooping VLAN .....	129
Figure 64 Advanced Application > Multicast > Multicast Setting > IGMP Filtering Profile .....	130
Figure 65 MVR Network Example .....	131
Figure 66 MVR Multicast Television Example .....	132
Figure 67 Advanced Application > Multicast > Multicast Setting > MVR .....	133
Figure 68 Advanced Application > Multicast > Multicast Setting > MVR: Group Configuration .....	135
Figure 69 MVR Configuration Example .....	136
Figure 70 MVR Configuration Example .....	136
Figure 71 MVR Group Configuration Example .....	137
Figure 72 MVR Group Configuration Example .....	137
Figure 73 AAA Server .....	139
Figure 74 Advanced Application > Auth and Acct .....	140
Figure 75 Advanced Application > Auth and Acct > RADIUS Server Setup .....	141
Figure 76 Advanced Application > Auth and Acct > TACACS+ Server Setup .....	143
Figure 77 Advanced Application > Auth and Acct > Auth and Acct Setup .....	145
Figure 78 Loop Guard vs STP .....	153
Figure 79 Switch in Loop State .....	154
Figure 80 Loop Guard - Probe Packet .....	154
Figure 81 Loop Guard - Network Loop .....	154

Figure 82 Advanced Application > Loop Guard .....	155
Figure 83 Static Routing Overview .....	159
Figure 84 IP Application > Static Routing .....	160
Figure 85 DiffServ: Differentiated Service Field .....	163
Figure 86 DiffServ Network .....	164
Figure 87 IP Application > DiffServ .....	165
Figure 88 IP Application > DHCP Status .....	168
Figure 89 IP Application > DHCP > Global .....	169
Figure 90 Global DHCP Relay Network Example .....	170
Figure 91 DHCP Relay Configuration Example .....	170
Figure 92 IP Application > DHCP > VLAN .....	171
Figure 93 DHCP Relay for Two VLANs .....	172
Figure 94 DHCP Relay for Two VLANs Configuration Example .....	172
Figure 95 Management > Maintenance .....	175
Figure 96 Load Factory Default: Start .....	176
Figure 97 Reboot System: Confirmation .....	177
Figure 98 Management > Maintenance > Firmware Upgrade .....	177
Figure 99 Management > Maintenance > Restore Configuration .....	178
Figure 100 Management > Maintenance > Backup Configuration .....	178
Figure 101 Management > Access Control .....	181
Figure 102 SNMP Management Model .....	182
Figure 103 Management > Access Control > SNMP .....	186
Figure 104 Management > Access Control > SNMP > Trap Group .....	188
Figure 105 Management > Access Control > Logins .....	190
Figure 106 SSH Communication Example .....	191
Figure 107 How SSH Works .....	191
Figure 108 HTTPS Implementation .....	193
Figure 109 Security Alert Dialog Box (Internet Explorer) .....	193
Figure 110 Security Certificate 1 (Netscape) .....	194
Figure 111 Security Certificate 2 (Netscape) .....	194
Figure 112 Example: Lock Denoting a Secure Connection .....	195
Figure 113 Management > Access Control > Service Access Control .....	195
Figure 114 Management > Access Control > Remote Management .....	196
Figure 115 Management > Diagnostic .....	199
Figure 116 Management > Syslog .....	202
Figure 117 Management > Syslog > Server Setup .....	203
Figure 118 Clustering Application Example .....	206
Figure 119 Management > Cluster Management .....	206
Figure 120 Cluster Management: Cluster Member Web Configurator Screen .....	207
Figure 121 Example: Uploading Firmware to a Cluster Member Switch .....	208
Figure 122 Management > Clustering Management > Configuration .....	209
Figure 123 MAC Table Flowchart .....	212
Figure 124 Management > MAC Table .....	212

Figure 125 Management > ARP Table .....	214
Figure 126 Management > Configure Clone .....	215
Figure 127 Console/Dial Backup Port Pin Layout .....	228
Figure 128 Pop-up Blocker .....	233
Figure 129 Internet Options: Privacy .....	234
Figure 130 Internet Options: Privacy .....	235
Figure 131 Pop-up Blocker Settings .....	235
Figure 132 Internet Options: Security .....	236
Figure 133 Security Settings - Java Scripting .....	237
Figure 134 Security Settings - Java .....	237
Figure 135 Java (Sun) .....	238
Figure 136 Mozilla Firefox: Tools > Options .....	239
Figure 137 Mozilla Firefox Content Security .....	239
Figure 138 Network Number and Host ID .....	242
Figure 139 Subnetting Example: Before Subnetting .....	244
Figure 140 Subnetting Example: After Subnetting .....	245

# List of Tables

Table 1 Front Panel Connections .....	37
Table 2 LED Descriptions .....	41
Table 3 Navigation Panel Sub-links Overview .....	47
Table 4 Web Configurator Screen Sub-links Details .....	48
Table 5 Navigation Panel Links .....	48
Table 6 Status .....	57
Table 7 Status > Port Details .....	59
Table 8 Basic Setting > System Info .....	64
Table 9 Basic Setting > General Setup .....	66
Table 10 Basic Setting > Switch Setup .....	68
Table 11 Basic Setting > IP Setup .....	71
Table 12 Basic Setting > Port Setup .....	73
Table 13 IEEE 802.1Q VLAN Terminology .....	78
Table 14 Advanced Application > VLAN: VLAN Status .....	80
Table 15 Advanced Application > VLAN > VLAN Detail .....	81
Table 16 Advanced Application > VLAN > Static VLAN .....	82
Table 17 Advanced Application > VLAN > VLAN Port Setting .....	83
Table 18 Advanced Application > VLAN: Port Based VLAN Setup .....	86
Table 19 Advanced Application > Static MAC Forwarding .....	90
Table 20 STP Path Costs .....	92
Table 21 STP Port States .....	92
Table 22 Advanced Application > Spanning Tree Protocol > Configuration .....	96
Table 23 Advanced Application > Spanning Tree Protocol > RSTP .....	97
Table 24 Advanced Application > Spanning Tree Protocol > Status: RSTP .....	99
Table 25 Advanced Application > Spanning Tree Protocol > MSTP .....	101
Table 26 Advanced Application > Spanning Tree Protocol > Status: MSTP .....	103
Table 27 Advanced Application > Bandwidth Control .....	106
Table 28 Advanced Application > Broadcast Storm Control .....	108
Table 29 Advanced Application > Mirroring .....	109
Table 30 Link Aggregation ID: Local Switch .....	112
Table 31 Link Aggregation ID: Peer Switch .....	112
Table 32 Advanced Application > Link Aggregation Status .....	112
Table 33 Advanced Application > Link Aggregation > Link Aggregation Setting .....	113
Table 34 Advanced Application > Link Aggregation > Link Aggregation Setting > LACP .....	115
Table 35 Advanced Application > Port Authentication > 802.1x .....	119
Table 36 Advanced Application > Port Security .....	122
Table 37 Advanced Application > Queuing Method .....	124
Table 38 Multicast Status .....	126

Table 39 Advanced Application > Multicast > Multicast Setting .....	127
Table 40 Advanced Application > Multicast > Multicast Setting > IGMP Snooping VLAN .....	129
Table 41 Advanced Application > Multicast > Multicast Setting > IGMP Filtering Profile .....	130
Table 42 Advanced Application > Multicast > Multicast Setting > MVR .....	133
Table 43 Advanced Application > Multicast > Multicast Setting > MVR: Group Configuration .....	135
Table 44 RADIUS vs TACACS+ .....	140
Table 45 Advanced Application > Auth and Acct > RADIUS Server Setup .....	141
Table 46 Advanced Application > Auth and Acct > TACACS+ Server Setup .....	143
Table 47 Advanced Application > Auth and Acct > Auth and Acct Setup .....	145
Table 48 Supported VSAs .....	147
Table 49 Supported Tunnel Protocol Attribute .....	148
Table 50 RADIUS Attributes - Exec Events via Console .....	150
Table 51 RADIUS Attributes - Exec Events via Telnet/SSH .....	150
Table 52 RADIUS Attributes - Exec Events via Console .....	150
Table 53 Advanced Application > Loop Guard .....	155
Table 54 IP Application > Static Routing .....	160
Table 55 Default DSCP-IEEE 802.1p Mapping .....	164
Table 56 IP Application > DiffServ .....	165
Table 57 IP Application > DHCP Status .....	168
Table 58 Relay Agent Information .....	168
Table 59 IP Application > DHCP > Global .....	169
Table 60 IP Application > DHCP > VLAN .....	171
Table 61 Management > Maintenance .....	175
Table 62 Filename Conventions .....	179
Table 63 General Commands for GUI-based FTP Clients .....	180
Table 64 Access Control Overview .....	181
Table 65 SNMP Commands .....	182
Table 66 SNMP System Traps .....	183
Table 67 SNMP Interface Traps .....	184
Table 68 AAA Traps .....	185
Table 69 SNMP IP Traps .....	185
Table 70 SNMP Switch Traps .....	185
Table 71 Management > Access Control > SNMP .....	187
Table 72 Management > Access Control > SNMP > Trap Group .....	189
Table 73 Management > Access Control > Logins .....	190
Table 74 Management > Access Control > Service Access Control .....	196
Table 75 Management > Access Control > Remote Management .....	196
Table 76 Management > Diagnostic .....	199
Table 77 Syslog Severity Levels .....	201
Table 78 Management > Syslog .....	202
Table 79 Management > Syslog > Server Setup .....	203
Table 80 ZyXEL Clustering Management Specifications .....	205
Table 81 Management > Cluster Management .....	207



---

Table 82 FTP Upload to Cluster Member Example .....	208
Table 83 Management > Clustering Management > Configuration .....	209
Table 84 Management > MAC Table .....	212
Table 85 Management > ARP Table .....	214
Table 86 Management > Configure Clone .....	216
Table 87 Hardware Specifications .....	223
Table 88 Firmware Specifications .....	224
Table 89 Switching Specifications .....	226
Table 90 Standards Supported .....	227
Table 91 Console/Dial Backup Port Pin Assignments .....	229
Table 92 Ethernet Cable Pin Assignments .....	229
Table 93 IP Address Network Number and Host ID Example .....	242
Table 94 Subnet Masks .....	243
Table 95 Maximum Host Numbers .....	243
Table 96 Alternative Subnet Mask Notation .....	243
Table 97 Subnet 1 .....	245
Table 98 Subnet 2 .....	246
Table 99 Subnet 3 .....	246
Table 100 Subnet 4 .....	246
Table 101 Eight Subnets .....	246
Table 102 24-bit Network Number Subnet Planning .....	247
Table 103 16-bit Network Number Subnet Planning .....	247



---

# PART I

# Introduction

---

Getting to Know Your Switch (29)

Hardware Installation and Connection (33)

Hardware Overview (37)



# Getting to Know Your Switch

This chapter introduces the main features and applications of the Switch.

## 1.1 Introduction

Your Switch is a stand-alone, layer-2, Ethernet switch with 24 100/1000 Mbps Ethernet ports, two mini-GBIC (SFP, Small Form-factor Pluggable) slots, and one 10/100 Mbps Ethernet port for out-of-band management.

With its built-in web configurator, managing and configuring the Switch is easy. In addition, the Switch can also be managed via Telnet, any terminal emulator program on the console port, or third-party SNMP management.

See [Chapter 33 on page 223](#) for a full list of software features available on the Switch.

### 1.1.1 Backbone Application

The Switch is an ideal solution for small networks where rapid growth can be expected in the near future. The Switch can be used standalone for a group of heavy traffic users. You can connect computers and servers directly to the Switch's port or connect other switches to the Switch.

In this example, all computers can share high-speed applications on the server. To expand the network, simply add more networking devices such as switches, routers, computers, print servers etc.

**Figure 1** Backbone Application

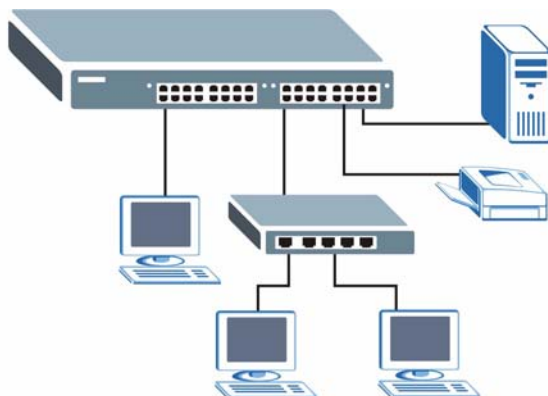

## 1.1.2 Bridging Example

In this example application the Switch connects different company departments (**RD** and **Sales**) to the corporate backbone. It can alleviate bandwidth contention and eliminate server and network bottlenecks. All users that need high bandwidth can connect to high-speed department servers via the Switch.

Moreover, the Switch eases supervision and maintenance by allowing network managers to centralize multiple servers at a single location.

**Figure 2** Bridging Application

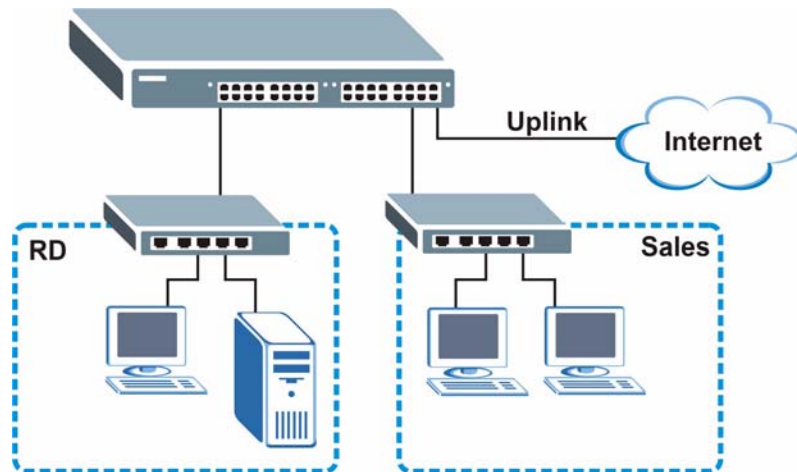

## 1.1.3 High Performance Switching Example

The Switch is ideal for connecting two networks that need high bandwidth. In the following example, use trunking to connect these two networks.

Switching to higher-speed LANs such as ATM (Asynchronous Transmission Mode) is not feasible for most people due to the expense of replacing all existing Ethernet cables and adapter cards, restructuring your network and complex maintenance. The Switch can provide the same bandwidth as ATM at much lower cost while still being able to use existing adapters and switches. Moreover, the current LAN structure can be retained as all ports can freely communicate with each other.

**Figure 3** High Performance Switched Workgroup Application

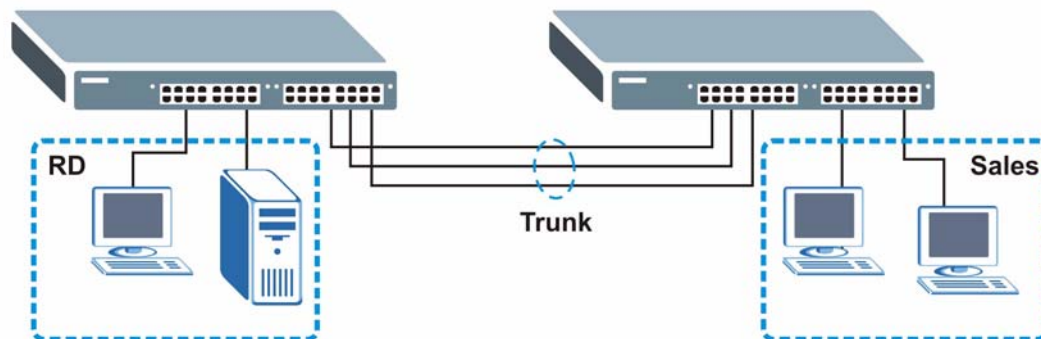

## 1.1.4 IEEE 802.1Q VLAN Application Examples

A VLAN (Virtual Local Area Network) allows a physical network to be partitioned into multiple logical networks. Stations on a logical network belong to one group. A station can belong to more than one group. With VLAN, a station cannot directly talk to or hear from stations that are not in the same group(s) unless such traffic first goes through a router.

For more information on VLANs, refer to [Chapter 8 on page 77](#).

### 1.1.4.1 Tag-based VLAN Example

Ports in the same VLAN group share the same frame broadcast domain thus increase network performance through reduced broadcast traffic. VLAN groups can be modified at any time by adding, moving or changing ports without any re-cabling.

Shared resources such as a server can be used by all ports in the same VLAN as the server. In the following figure only ports that need access to the server need to be part of VLAN 1. Ports can belong to other VLAN groups too.

**Figure 4** Shared Server Using VLAN Example

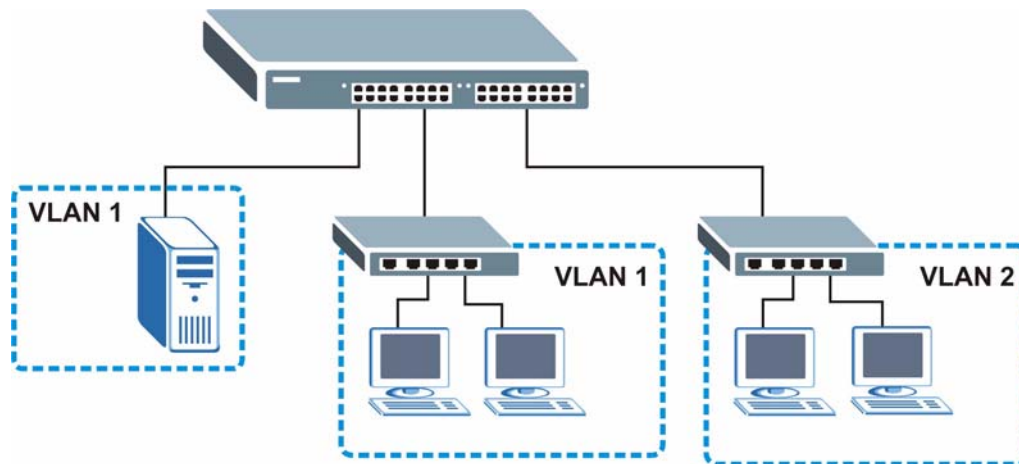

## 1.2 Ways to Manage the Switch

Use any of the following methods to manage the Switch.

- Web Configurator. This is recommended for everyday management of the Switch using a (supported) web browser. See [Chapter 4 on page 45](#).
- Command Line Interface. Line commands offer an alternative to the Web Configurator and may be necessary to configure advanced features. See the CLI Reference Guide.
- FTP. Use File Transfer Protocol for firmware upgrades and configuration backup/restore. See [Section 24.8 on page 179](#).
- SNMP. The device can be monitored and/or managed by an SNMP manager. See [Section 25.3 on page 182](#).

## 1.3 Good Habits for Managing the Switch

Do the following things regularly to make the Switch more secure and to manage the Switch more effectively.

- Change the password. Use a password that's not easy to guess and that consists of different types of characters, such as numbers and letters.
- Write down the password and put it in a safe place.
- Back up the configuration (and make sure you know how to restore it). Restoring an earlier working configuration may be useful if the device becomes unstable or even crashes. If you forget your password, you will have to reset the Switch to its factory default settings. If you backed up an earlier configuration file, you would not have to totally re-configure the Switch. You could simply restore your last configuration.



# Hardware Installation and Connection

This chapter shows you how to install and connect the Switch.

## 2.1 Freestanding Installation

- 1 Make sure the Switch is clean and dry.
- 2 Set the Switch on a smooth, level surface strong enough to support the weight of the Switch and the connected cables. Make sure there is a power outlet nearby.
- 3 Make sure there is enough clearance around the Switch to allow air circulation and the attachment of cables and the power cord.
- 4 Remove the adhesive backing from the rubber feet.
- 5 Attach the rubber feet to each corner on the bottom of the Switch. These rubber feet help protect the Switch from shock or vibration and ensure space between devices when stacking.

**Figure 5** Attaching Rubber Feet

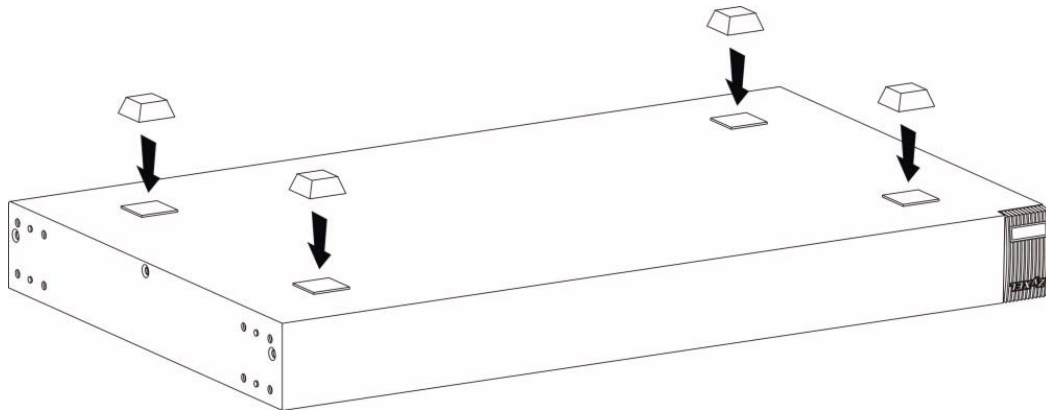

---

Do NOT block the ventilation holes. Leave space between devices when stacking.

---



For proper ventilation, allow at least 4 inches (10 cm) of clearance at the front and 3.4 inches (8 cm) at the back of the Switch. This is especially important for enclosed rack installations.

## 2.2 Mounting the Switch on a Rack

This section lists the rack mounting requirements and precautions and describes the installation steps.

### 2.2.1 Rack-mounted Installation Requirements

- Two mounting brackets.
- Eight M3 flat head screws and a #2 Philips screwdriver.
- Four M5 flat head screws and a #2 Philips screwdriver.



Failure to use the proper screws may damage the unit.

#### 2.2.1.1 Precautions

- Make sure the rack will safely support the combined weight of all the equipment it contains.
- Make sure the position of the Switch does not make the rack unstable or top-heavy. Take all necessary precautions to anchor the rack securely before installing the unit.

### 2.2.2 Attaching the Mounting Brackets to the Switch

- 1 Position a mounting bracket on one side of the Switch, lining up the four screw holes on the bracket with the screw holes on the side of the Switch.

**Figure 6** Attaching the Mounting Brackets

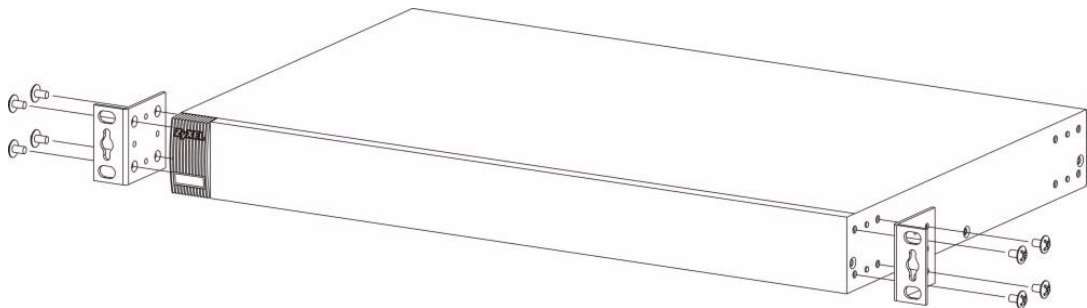

- 2 Using a #2 Philips screwdriver, install the M3 flat head screws through the mounting bracket holes into the Switch.

- 3 Repeat steps 1 and 2 to install the second mounting bracket on the other side of the Switch.
- 4 You may now mount the Switch on a rack. Proceed to the next section.

### 2.2.3 Mounting the Switch on a Rack

- 1 Position a mounting bracket (that is already attached to the Switch) on one side of the rack, lining up the two screw holes on the bracket with the screw holes on the side of the rack.

**Figure 7** Mounting the Switch on a Rack

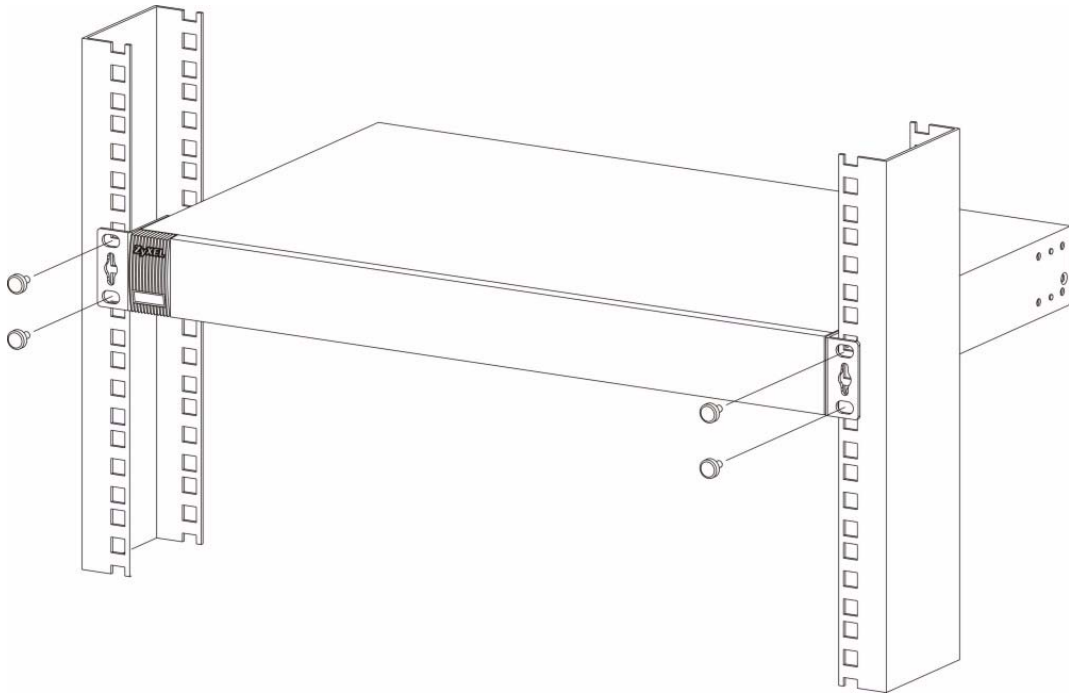

- 2 Using a #2 Philips screwdriver, install the M5 flat head screws through the mounting bracket holes into the rack.
- 3 Repeat steps 1 and 2 to attach the second mounting bracket on the other side of the rack.



# Hardware Overview

This chapter describes the front panel and rear panel of the Switch and shows you how to make the hardware connections.

## 3.1 Front Panel Connections

The figure below shows the front panel of the Switch.

**Figure 8** Front Panel

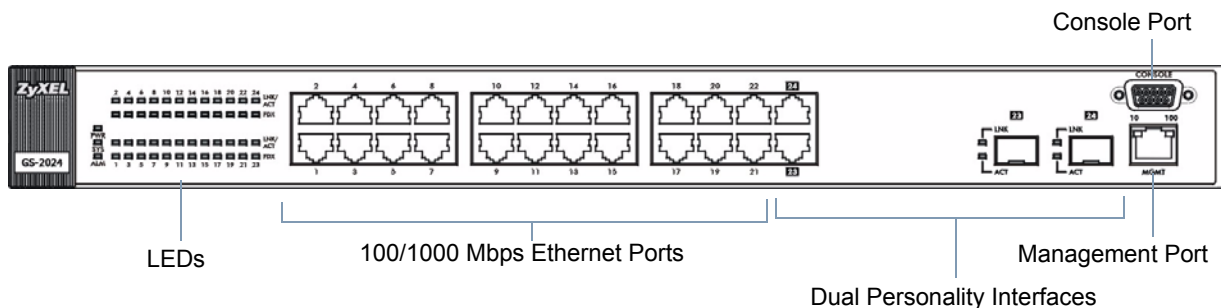

The following table describes the port labels on the front panel.

**Table 1** Front Panel Connections

LABEL	DESCRIPTION
22 100/1000 Mbps RJ-45 Ethernet Ports	Connect these Ethernet ports to high-bandwidth backbone network Ethernet switches or use them to daisy-chain other switches.
2 Dual Personality Interfaces	<p>Each interface has one 1000Base-T copper RJ-45 port and one mini-GBIC (Gigabit Interface Converter) fiber port, with one port active at a time.</p> <ul style="list-style-type: none"> <li>2 1000Base-T Ports: Connect these ports to high-bandwidth backbone network Ethernet switches using Category 5/5e/6 1000Base-T Ethernet cables.</li> <li>2 Mini-GBIC Ports: Use Small Form-Factor Pluggable (SFP) transceivers in these ports for 1000Base-X fiber-optic connections to backbone Ethernet switches.</li> </ul>
Console Port	The console port is for local configuration of the Switch.
Management Port	Connect to a computer using an RJ-45 Ethernet cable for local configuration of the Switch.

### 3.1.1 1000Base-T Ports

The Switch has 24 1000Base-T auto-negotiating, auto-crossover Ethernet ports. In 100/1000 Mbps Gigabit Ethernet, the speed can be 100 Mbps or 1000 Mbps. The duplex mode can be both half or full duplex at 100 Mbps and full duplex only at 1000 Mbps.

An auto-negotiating port can detect and adjust to the optimum Ethernet speed (100/1000 Mbps) and duplex mode (full duplex or half duplex) of the connected device.

An auto-crossover (auto-MDI/MDI-X) port automatically works with a straight-through or crossover Ethernet cable.

Two of the 1000Base-T Ethernet ports are paired with a mini-GBIC slot to create a dual personality interface. The Switch uses up to one connection for each mini-GBIC and 1000Base-T Ethernet pair. The mini-GBIC slots have priority over the Gigabit ports. This means that if a mini-GBIC slot and the corresponding Gigabit port are connected at the same time, the Gigabit port will be disabled.

When auto-negotiation is turned on, a Gigabit port negotiates with the peer automatically to determine the connection speed and duplex mode. If the peer Ethernet port does not support auto-negotiation or turns off this feature, the Switch determines the connection speed by detecting the signal on the cable and using half duplex mode. When the Switch's auto-negotiation is turned off, a Gigabit port uses the pre-configured speed and duplex mode when making a connection, thus requiring you to make sure that the settings of the peer Ethernet port are the same in order to connect.

#### 3.1.1.1 Default Ethernet Settings

The factory default negotiation settings for the Ethernet ports on the Switch are:

- Speed: Auto
- Duplex: Auto
- Flow control: Off
- Link aggregation: Off

#### 3.1.1.2 Auto-crossover

All ports are auto-crossover, that is auto-MDIX ports (Media Dependent Interface Crossover), so you may use either a straight-through Ethernet cable or crossover Ethernet cable for all Gigabit port connections. Auto-crossover ports automatically sense whether they need to function as crossover or straight ports, so crossover cables can connect both computers and switches/hubs.

### 3.1.2 Dual Personality Interfaces

Dual Personality interfaces comprise 1000Base-T/mini-GBIC combo ports. For each interface you can connect either to the 1000Base-T port or the mini-GBIC port. The mini-GBIC ports have priority over the 1000Base-T ports. This means that if a mini-GBIC port and the corresponding 1000Base-T port are connected at the same time, the 1000Base-T port will be disabled.

### 3.1.2.1 Mini-GBIC Slots

These are slots for Small Form-Factor Pluggable (SFP) transceivers. A transceiver is a single unit that houses a transmitter and a receiver. Use a transceiver to connect a fiber-optic cable to the Switch. The Switch does not come with transceivers. You must use transceivers that comply with the Small Form-Factor Pluggable (SFP) Transceiver MultiSource Agreement (MSA). See the SFF committee's INF-8074i specification Rev 1.0 for details.

You can change transceivers while the Switch is operating. You can use different transceivers to connect to Ethernet switches with different types of fiber-optic connectors.

- Type: SFP connection interface
- Connection speed: 1 Gigabit per second (Gbps)



**To avoid possible eye injury, do not look into an operating fiber-optic module's connectors.**

#### 3.1.2.1.1 Transceiver Installation

Use the following steps to install a mini GBIC transceiver (SFP or XFP module).

- 1 Insert the transceiver into the slot with the exposed section of PCB board facing down.

**Figure 9** Transceiver Installation Example

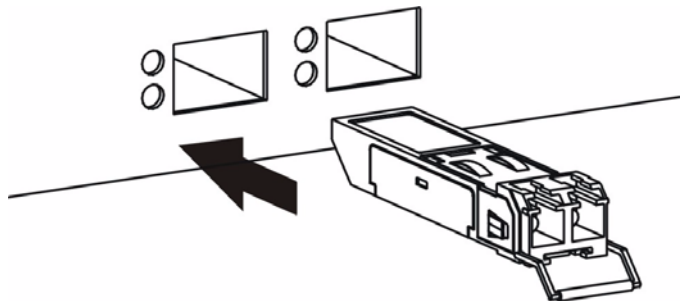

- 2 Press the transceiver firmly until it clicks into place.
- 3 The Switch automatically detects the installed transceiver. Check the LEDs to verify that it is functioning properly.

**Figure 10** Installed Transceiver

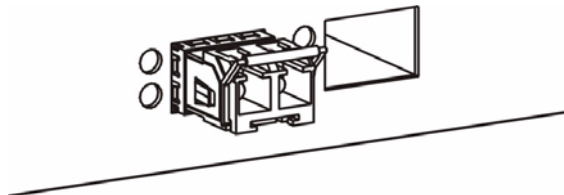

#### 3.1.2.1.2 Transceiver Removal

Use the following steps to remove a mini GBIC transceiver (SFP module).

- 1 Open the transceiver's latch (latch styles vary).

**Figure 11** Opening the Transceiver's Latch Example

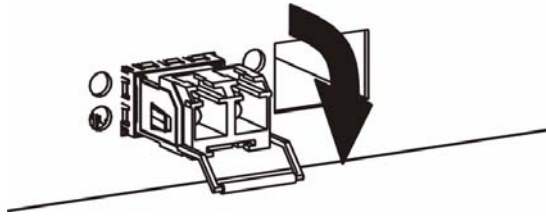

2 Pull the transceiver out of the slot.

**Figure 12** Transceiver Removal Example

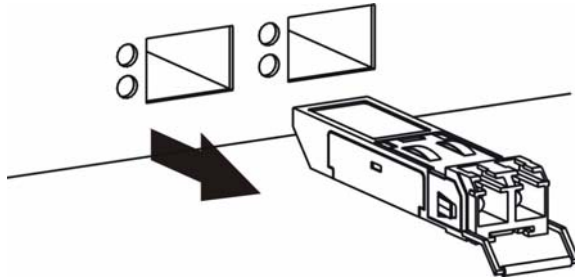

### 3.1.3 Console Port

For local management, you can use a computer with terminal emulation software configured to the following parameters:

- VT100 terminal emulation
- 9600 bps
- No parity, 8 data bits, 1 stop bit
- No flow control

Connect the male 9-pin end of the RS-232 console cable to the console port of the Switch. Connect the female end to a serial port (COM1, COM2 or other COM port) of your computer.

### 3.1.4 Management Port

The **MGMT** (management) port is used for local management. Connect directly to this port using an Ethernet cable. You can configure the Switch via Telnet or the web configurator.

The default IP address of the management port is 192.168.0.1 with a subnet mask of 255.255.255.0.

## 3.2 Rear Panel

The following figure shows the rear panel of the Switch.



Figure 13 Rear Panel

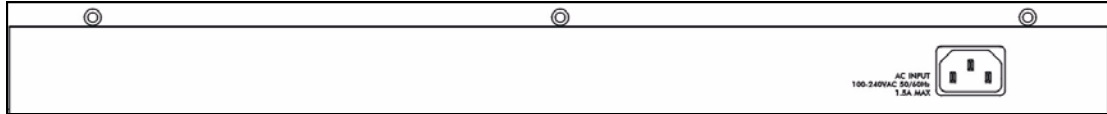

### 3.2.1 Power Connector



Make sure you are using the correct power source as shown on the panel.

Make sure you are using the correct power source as shown on the panel.

To connect the power to the Switch, insert the female end of power cord to the power receptacle on the rear panel. Connect the other end of the supplied power cord to a power outlet. Make sure that no objects obstruct the airflow of the fans.

## 3.3 LEDs

After you connect the power to the Switch, view the LEDs to ensure proper functioning of the Switch and as an aid in troubleshooting.

Table 2 LED Descriptions

LED	COLOR	STATUS	DESCRIPTION
PWR	Green	On	The system is turned on.
		Off	The system is off.
SYS	Green	Blinking	The system is rebooting and performing self-diagnostic tests.
		On	The system is on and functioning properly.
		Off	The power is off or the system is not ready or is malfunctioning.
ALM	Red	On	There is a hardware failure.
		Off	The system is functioning normally.
Gigabit Ports			
LNK/ACT	Green	Blinking	The system is transmitting/receiving to/from an Ethernet network.
		On	The link to a 10/1000 Mbps Ethernet network is up.
	Amber	Blinking	The system is transmitting/receiving to/from an Ethernet network.
		On	The link to a 100 Mbps Ethernet network is up.
	Off	The link to an Ethernet network is down.	
FDX	Amber	On	The Gigabit port is negotiating in full-duplex mode.
		Off	The Gigabit port is negotiating in half-duplex mode.
Mini-GBIC Slots			
LNK	Green	On	The link to this port is up.
		Off	The link to this port is not connected.

**Table 2** LED Descriptions (continued)

LED	COLOR	STATUS	DESCRIPTION
ACT	Green	Blinking	This port is receiving or transmitting data.
MGMT			
10	Green	Blinking	The system is transmitting/receiving to/from an Ethernet device.
		On	The port is connected at 10Mbps.
		Off	The port is not connected at 10Mbps or to an Ethernet device.
100	Amber	Blinking	The system is transmitting/receiving to/from an Ethernet device.
		On	The port is connected at 100Mbps.
		Off	The port is not connected at 100Mbps or to an Ethernet device.

---

# PART II

# Basic Configuration

---

- The Web Configurator (45)
- Initial Setup Example (53)
- System Status and Port Statistics (57)
- Basic Setting (63)



# The Web Configurator

This section introduces the configuration and functions of the web configurator.

## 4.1 Introduction

The web configurator is an HTML-based management interface that allows easy Switch setup and management via Internet browser. Use Internet Explorer 6.0 and later or Netscape Navigator 7.0 and later versions. The recommended screen resolution is 1024 by 768 pixels.

In order to use the web configurator you need to allow:

- Web browser pop-up windows from your device. Web pop-up blocking is enabled by default in Windows XP SP (Service Pack) 2.
- JavaScript (enabled by default).
- Java permissions (enabled by default).

## 4.2 System Login

- 1 Start your web browser.
- 2 Type “http://” and the IP address of the Switch (for example, the default management IP address is 192.168.1.1 through an in-band (non-**MGMT**) port and 192.168.0.1 through the **MGMT** port) in the Location or Address field. Press [ENTER].
- 3 The login screen appears. The default username is **admin** and associated default password is **1234**. The date and time display as shown if you have not configured a time server nor manually entered a time and date in the **General Setup** screen.

**Figure 14** Web Configurator: Login



4 Click **OK** to view the first web configurator screen.

### 4.3 The Status Screen

The **Status** screen is the first screen that displays when you access the web configurator. The following figure shows the navigating components of a web configurator screen.

**Figure 15** Web Configurator Home Screen (Status)

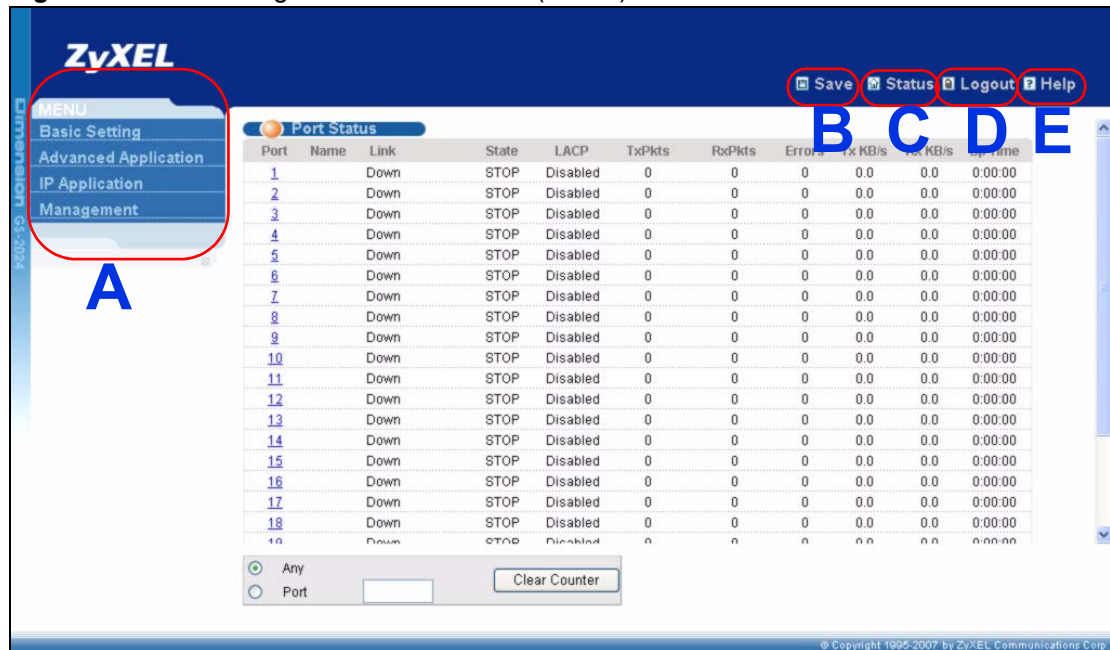

**A** - Click the menu items to open submenu links, and then click on a submenu link to open the screen in the main window.

**B, C, D, E** - These are quick links which allow you to perform certain tasks no matter which screen you are currently working in.

**B** - Click this link to save your configuration into the Switch’s nonvolatile memory. Nonvolatile memory is saved in the configuration file from which the Switch booted from and it stays the same even if the Switch’s power is turned off. See [Section 24.3 on page 176](#) for information on saving your settings to a specific configuration file.





**C** - Click this link to go to the status page of the Switch.

**D** - Click this link to log out of the web configurator.

**E** - Click this link to display web help pages. The help pages provide descriptions for all of the configuration screens.

In the navigation panel, click a main link to reveal a list of submenu links.

**Table 3** Navigation Panel Sub-links Overview

BASIC SETTING	ADVANCED APPLICATION	IP APPLICATION	MANAGEMENT
			

The following table lists the various web configurator screens within the sub-links.

**Table 4** Web Configurator Screen Sub-links Details

BASIC SETTING	ADVANCED APPLICATION	IP APPLICATION	MANAGEMENT
System Info General Setup Switch Setup IP Setup Port Setup	VLAN Status VLAN Port Setting Static VLAN VLAN Detail Static MAC Forwarding Spanning Tree Protocol Status Spanning Tree Configuration Rapid Spanning Tree Protocol Multiple Spanning Tree Protocol Bandwidth Control Broadcast Storm Control Mirroring Link Aggregation Status Link Aggregation Setting - Link Aggregation Control Protocol Port Authentication 802.1x Port Security Queuing Method Multicast Status Multicast Setting - IGMP Snooping VLAN - IGMP Filtering Profile - MVR -- Group Configuration Authentication and Accounting RADIUS Server Setup TACACS+ Server Setup Auth and Acct Setup Loop Guard	Static Routing DiffServ DHCP Status DHCP Relay VLAN Setting	Maintenance Firmware Upgrade Restore Configuration Backup Configuration Access Control SNMP - Trap Group Logins Service Access Control Remote Management Diagnostic Syslog Setup Syslog Server Setup Clustering Management Status Clustering Management Configuration MAC Table ARP Table Configure Clone

The following table describes the links in the navigation panel.

**Table 5** Navigation Panel Links

LINK	DESCRIPTION
Basic Settings	
System Info	This link takes you to a screen that displays general system and hardware monitoring information.
General Setup	This link takes you to a screen where you can configure general identification information and time settings for the Switch.
Switch Setup	This link takes you to a screen where you can set up global Switch parameters such as VLAN type, MAC address learning, GARP and priority queues.
IP Setup	This link takes you to a screen where you can configure the IP address, subnet mask (necessary for Switch management) and DNS (domain name server) and set up to 64 IP routing domains.
Port Setup	This link takes you to screens where you can configure speed, flow control and priority settings for individual Switch ports.
Advanced Application	



**Table 5** Navigation Panel Links (continued)

LINK	DESCRIPTION
VLAN	This link takes you to screens where you can configure port-based or 802.1Q VLAN (depending on what you configured in the <b>Switch Setup</b> menu).
Static MAC Forwarding	This link takes you to screens where you can configure static MAC addresses for a port. These static MAC addresses do not age out.
Spanning Tree Protocol	This link takes you to screens where you can configure the RSTP/MSTP to prevent network loops.
Bandwidth Control	This link takes you to screens where you can cap the maximum bandwidth allowed from specified source(s) to specified destination(s).
Broadcast Storm Control	This link takes you to a screen to set up broadcast filters.
Mirroring	This link takes you to screens where you can copy traffic from one port to another port in order that you can examine the traffic from the first port without interference.
Link Aggregation	This link takes you to screen where you can logically aggregate physical links to form one logical, higher-bandwidth link.
Port Authentication	This link takes you to a screen where you can configure IEEE 802.1x port authentication as well as MAC authentication for clients communicating via the Switch.
Port Security	This link takes you to a screen where you can activate MAC address learning.
Queuing Method	This link takes you to a screen where you can configure queuing with associated queue weights for each port.
Multicast	This link takes you to screen where you can configure various multicast features and create multicast VLANs.
Auth and Acct	This link takes you to screens where you can configure authentication and accounting services via external servers. The external servers can be either RADIUS (Remote Authentication Dial-In User Service) or TACACS+ (Terminal Access Controller Access-Control System Plus).
Loop Guard	This link takes you to a screen where you can configure protection against network loops that occur on the edge of your network.
IP Application	
Static Route	This link takes you to a screen where you can configure static routes. A static route defines how the Switch should forward traffic by configuring the TCP/IP parameters manually.
DiffServ	This link takes you to screens where you can enable DiffServ and set DSCP-to-IEEE802.1p mappings.
DHCP	This link takes you to screens where you can configure the DHCP settings.
Management	
Maintenance	This link takes you to screens where you can perform firmware and configuration file maintenance as well as reboot the system.
Access Control	This link takes you to screens where you can change the system login password and configure SNMP and remote management.
Diagnostic	This link takes you to screens where you can view system logs and can test port(s).
Syslog	This link takes you to screens where you can setup system logs and a system log server.
Cluster Management	This link takes you to a screen where you can configure clustering management and view its status.
MAC Table	This link takes you to a screen where you can view the MAC address and VLAN ID of a device attach to a port. You can also view what kind of device it is.

**Table 5** Navigation Panel Links (continued)

LINK	DESCRIPTION
ARP Table	This link takes you to a screen where you can view the MAC address – IP address resolution table.
Configure Clone	This link takes you to a screen where you can copy attributes of one port to (an)other port(s).

### 4.3.1 Change Your Password

After you log in for the first time, it is recommended you change the default administrator password. Click **Management > Access Control > Logins** to display the next screen.

**Figure 16** Change Administrator Login Password

The screenshot shows the 'Logins' page with the 'Administrator' user selected. The password change form is highlighted with a red box. Below the form, a warning message states: "Please record your new password whenever you change it. The system will lock you out if you have forgotten your password." At the bottom, there is an 'Edit Logins' table with columns for 'Login', 'User Name', 'Password', and 'Retype to confirm', and two buttons: 'Apply' and 'Cancel'.

## 4.4 Saving Your Configuration

When you are done modifying the settings in a screen, click **Apply** to save your changes back to the run-time memory. Settings in the run-time memory are lost when the Switch's power is turned off.

Click the **Save** link in the upper right hand corner of the web configurator to save your configuration to nonvolatile memory. Nonvolatile memory refers to the Switch's storage that remains even if the Switch's power is turned off.



Use the **Save** link when you are done with a configuration session.

## 4.5 Switch Lockout

You could block yourself (and all others) from using in-band-management (managing through the data ports) if you do one of the following:

- 1 Delete the management VLAN (default is VLAN 1).
- 2 Delete all port-based VLANs with the CPU port as a member. The “CPU port” is the management port of the Switch.
- 3 Filter all traffic to the CPU port.
- 4 Disable all ports.
- 5 Misconfigure the text configuration file.
- 6 Forget the password and/or IP address.
- 7 Prevent all services from accessing the Switch.
- 8 Change a service port number but forget it.



---

Be careful not to lock yourself and others out of the Switch. If you do lock yourself out, try using out-of-band management (via the management port) to configure the Switch.

---

## 4.6 Resetting the Switch

If you lock yourself (and others) from the Switch or forget the administrator password, you will need to reload the factory-default configuration file or reset the Switch back to the factory defaults.

### 4.6.1 Reload the Configuration File

Uploading the factory-default configuration file replaces the current configuration file with the factory-default configuration file. This means that you will lose all previous configurations and the speed of the console port will be reset to the default of 9600 bps with 8 data bit, no parity, one stop bit and flow control set to none. The password will also be reset to “1234” and the IP address to 192.168.1.1.

To upload the configuration file, do the following:

- 1 Connect to the console port using a computer with terminal emulation software. See [Section 3.2 on page 40](#) for details.
- 2 Disconnect and reconnect the Switch’s power to begin a session. When you reconnect the Switch’s power, you will see the initial screen.
- 3 When you see the message “Press any key to enter Debug Mode within 3 seconds . . .” press any key to enter debug mode.
- 4 Type `atlc` after the “Enter Debug Mode” message.
- 5 Wait for the “Starting XMODEM upload” message before activating XMODEM upload on your terminal.
- 6 After a configuration file upload, type `atgo` to restart the Switch.

**Figure 17** Resetting the Switch: Via the Console Port

```
Bootbase Version: V0.6 | 05/18/2004 15:28:28
AM:Size = 32 Mbytes
DRAM POST: Testing: 32768K OK
DRAM Test SUCCESS !
FLASH: Intel 32M

ZyNOS Version: V3.60(LT.0)b3 | 06/21/2005 17:00:44

Press any key to enter debug mode within 3 seconds.
.....
Enter Debug Mode

ras> atlc
Starting XMODEM upload (CRC mode)....
CCCCCCCCCCCCCCCC
Total 262144 bytes received.
Erasing..
.....
OK
ras> atgo
```

The Switch is now reinitialized with a default configuration file including the default password of “1234”.

## 4.7 Logging Out of the Web Configurator

Click **Logout** in a screen to exit the web configurator. You have to log in with your password again after you log out. This is recommended after you finish a management session for security reasons.

**Figure 18** Web Configurator: Logout Screen



## 4.8 Help

The web configurator’s online help has descriptions of individual screens and some supplementary information.

Click the **Help** link from a web configurator screen to view an online help description of that screen.

# Initial Setup Example

This chapter shows how to set up the switch for an example network.

## 5.1 Overview

The following lists the configuration steps for the initial setup:

- Create a VLAN
- Set port VLAN ID
- Configure the switch IP management address

### 5.1.1 Creating a VLAN

VLANs confine broadcast frames to the VLAN group in which the port(s) belongs. You can do this with port-based VLAN or tagged static VLAN with fixed port members.

In this example, you want to configure port 10 as a member of VLAN 2.

**Figure 19** Initial Setup Network Example: VLAN

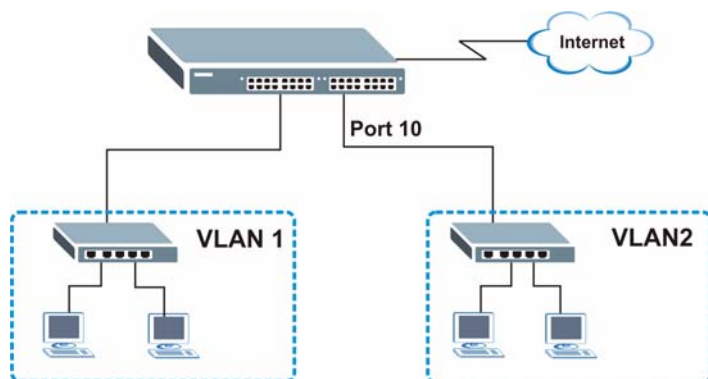

- 1 Click **Advanced Application** and **VLAN** in the navigation panel and click the **Static VLAN** link.

VLAN Status		VLAN Port Setting		Static VLAN
The Number of VLAN = 1				
Index	VID	Elapsed Time	Status	
1	1	80:49:10	Static	

- In the **Static VLAN** screen, select **ACTIVE**, enter a descriptive name in the **Name** field and enter 2 in the **VLAN Group ID** field for the **VLAN2** network.

Port	Control	Tagging
*	Normal	<input checked="" type="checkbox"/> Tx Tagging
1	<input checked="" type="radio"/> Normal <input type="radio"/> Fixed <input type="radio"/> Forbidden	<input checked="" type="checkbox"/> Tx Tagging
2	<input checked="" type="radio"/> Normal <input type="radio"/> Fixed <input type="radio"/> Forbidden	<input checked="" type="checkbox"/> Tx Tagging
3	<input checked="" type="radio"/> Normal <input type="radio"/> Fixed <input type="radio"/> Forbidden	<input checked="" type="checkbox"/> Tx Tagging
4	<input checked="" type="radio"/> Normal <input type="radio"/> Fixed <input type="radio"/> Forbidden	<input checked="" type="checkbox"/> Tx Tagging
5	<input checked="" type="radio"/> Normal <input type="radio"/> Fixed <input type="radio"/> Forbidden	<input checked="" type="checkbox"/> Tx Tagging
6	<input checked="" type="radio"/> Normal <input type="radio"/> Fixed <input type="radio"/> Forbidden	<input checked="" type="checkbox"/> Tx Tagging
7	<input checked="" type="radio"/> Normal <input type="radio"/> Fixed <input type="radio"/> Forbidden	<input checked="" type="checkbox"/> Tx Tagging
8	<input checked="" type="radio"/> Normal <input type="radio"/> Fixed <input type="radio"/> Forbidden	<input checked="" type="checkbox"/> Tx Tagging
9	<input checked="" type="radio"/> Normal <input type="radio"/> Fixed <input type="radio"/> Forbidden	<input checked="" type="checkbox"/> Tx Tagging
10	<input type="radio"/> Normal <input checked="" type="radio"/> Fixed <input type="radio"/> Forbidden	<input type="checkbox"/> Tx Tagging



The **VLAN Group ID** field in this screen and the **VID** field in the **IP Setup** screen refer to the same VLAN ID.

- Since the **VLAN2** network is connected to port 10 on the switch, select **Fixed** to configure port 10 to be a permanent member of the VLAN only.
- To ensure that VLAN-unaware devices (such as computers and hubs) can receive frames properly, clear the **TX Tagging** check box to set the switch to remove VLAN tags before sending.
- Click **Add** to save the settings.

### 5.1.2 Setting Port VID

Use PVID to add a tag to incoming untagged frames received on that port so that the frames are forwarded to the VLAN group that the tag defines.

In the example network, configure 2 as the port VID on port 10 so that any untagged frames received on that port get sent to VLAN 2.

**Figure 20** Initial Setup Network Example: Port VID

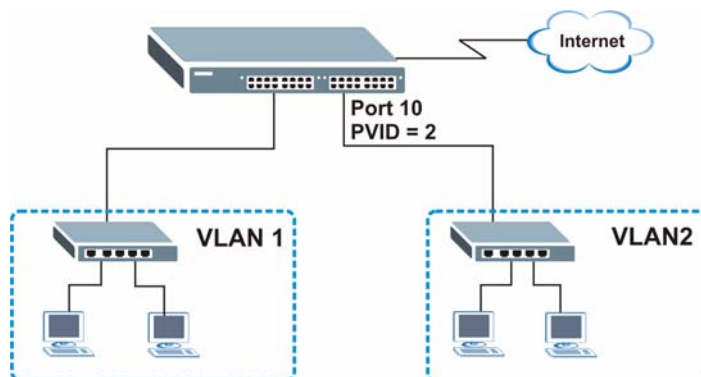

- 1 Click **Advanced Applications** and **VLAN** in the navigation panel. Then click the **VLAN Port Setting** link.
- 2 Enter 2 in the **PVID** field for port 10 and click **Apply** to save the settings.

Port	Ingress Check	PVID	GVRP	Acceptable Frame Type	VLAN Trunking
*	<input type="checkbox"/>		<input type="checkbox"/>	All	<input type="checkbox"/>
1	<input type="checkbox"/>	1	<input type="checkbox"/>	All	<input type="checkbox"/>
2	<input type="checkbox"/>	1	<input type="checkbox"/>	All	<input type="checkbox"/>
3	<input type="checkbox"/>	1	<input type="checkbox"/>	All	<input type="checkbox"/>
4	<input type="checkbox"/>	1	<input type="checkbox"/>	All	<input type="checkbox"/>
5	<input type="checkbox"/>	1	<input type="checkbox"/>	All	<input type="checkbox"/>
6	<input type="checkbox"/>	1	<input type="checkbox"/>	All	<input type="checkbox"/>
7	<input type="checkbox"/>	1	<input type="checkbox"/>	All	<input type="checkbox"/>
8	<input type="checkbox"/>	1	<input type="checkbox"/>	All	<input type="checkbox"/>
9	<input type="checkbox"/>	1	<input type="checkbox"/>	All	<input type="checkbox"/>
10	<input type="checkbox"/>	2	<input type="checkbox"/>	All	<input type="checkbox"/>

### 5.1.3 Configuring Switch Management IP Address

The default management IP address of the switch is 192.168.1.1. You can configure another IP address in a different subnet for management purposes. The following figure shows an example.

**Figure 21** Initial Setup Example: Management IP Address

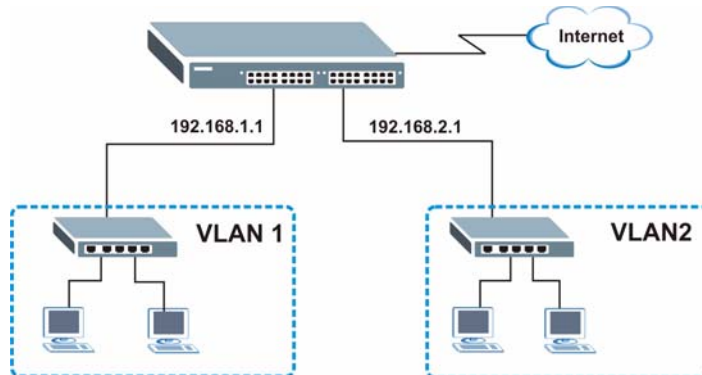

- 1 Connect your computer to any Ethernet port on the switch. Make sure your computer is in the same subnet as the switch.
- 2 Open your web browser and enter 192.168.1.1 (the default IP address) in the address bar to access the web configurator. See [Section 4.2 on page 45](#) for more information.

- 3 Click **Basic Setting** and **IP Setup** in the navigation panel.
- 4 Configure the related fields in the **IP Setup** screen.  
For the **VLAN2** network, enter 192.168.2.1 as the IP address and 255.255.255.0 as the subnet mask.
- 5 In the **VID** field, enter the ID of the VLAN group to which you want this management IP address to belong. This is the same as the VLAN ID you configure in the **Static VLAN** screen.
- 6 Click **Add**.

The screenshot displays the IP Setup configuration interface. At the top, the Domain Name Server is set to 0.0.0.0, and Default Management is set to In-band. The In-band Management IP Address section is selected, with Static IP Address chosen. The IP Address is 192.168.1.1, IP Subnet Mask is 255.255.255.0, and Default Gateway is 0.0.0.0. The VID is set to 1. The Out-of-band Management IP Address section shows IP Address 192.168.0.1, IP Subnet Mask 255.255.255.0, and Default Gateway 0.0.0.0. Below these sections are Apply and Cancel buttons. The In-band IP Addresses table is highlighted with a red box, showing the configuration for the selected IP address: IP Address 192.168.2.1, IP Subnet Mask 255.255.255.0, VID 2, and Default Gateway 0.0.0.0. The table has columns for Index, IP Address, IP Subnet Mask, VID, Default Gateway, and Delete. Below the table are Add and Cancel buttons, and further down, Delete and Cancel buttons.



# System Status and Port Statistics

This chapter describes the system status (web configurator home page) and port details screens.

## 6.1 Overview

The home screen of the web configurator displays a port statistical summary with links to each port showing statistical details.

## 6.2 Port Status Summary

To view the port statistics, click **Status** in all web configurator screens to display the **Status** screen as shown next.

**Figure 22** Status

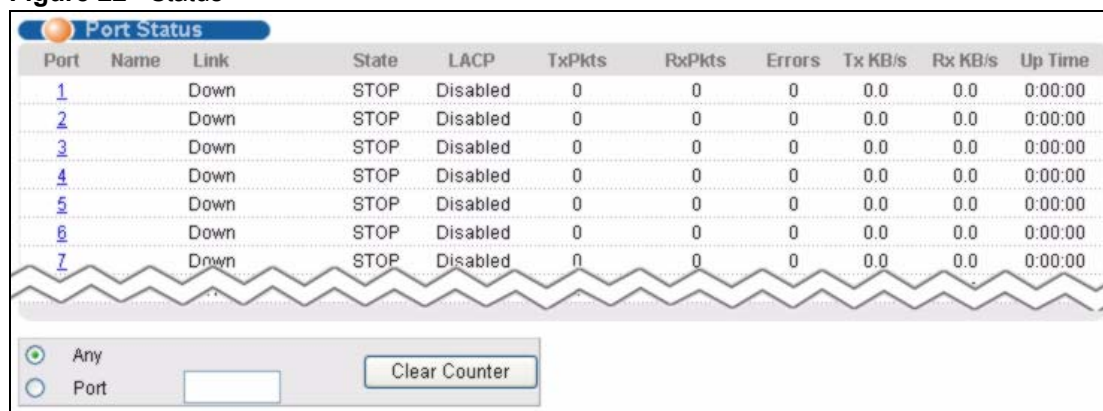

Port	Name	Link	State	LACP	TxPkts	RxPkts	Errors	Tx KB/s	Rx KB/s	Up Time
<a href="#">1</a>		Down	STOP	Disabled	0	0	0	0.0	0.0	0:00:00
<a href="#">2</a>		Down	STOP	Disabled	0	0	0	0.0	0.0	0:00:00
<a href="#">3</a>		Down	STOP	Disabled	0	0	0	0.0	0.0	0:00:00
<a href="#">4</a>		Down	STOP	Disabled	0	0	0	0.0	0.0	0:00:00
<a href="#">5</a>		Down	STOP	Disabled	0	0	0	0.0	0.0	0:00:00
<a href="#">6</a>		Down	STOP	Disabled	0	0	0	0.0	0.0	0:00:00
<a href="#">7</a>		Down	STOP	Disabled	0	0	0	0.0	0.0	0:00:00

Any  
 Port

The following table describes the labels in this screen.

**Table 6** Status

LABEL	DESCRIPTION
Port	This identifies the Ethernet port. Click a port number to display the <b>Port Details</b> screen (refer to <a href="#">Figure 23 on page 59</a> ).
Name	This is the name you assigned to this port in the <b>Basic Setting &gt; Port Setup</b> screen.

**Table 6** Status (continued)

LABEL	DESCRIPTION
Link	This field displays the speed (either <b>10M</b> for 10 Mbps, <b>100M</b> for 100 Mbps, <b>1000M</b> for 1000 Mbps, and <b>10G</b> for 10 Gbps) and the duplex ( <b>F</b> for full duplex or <b>H</b> for half). It also shows the cable type ( <b>Copper</b> or <b>SFP</b> ) for the combo ports.
State	If STP (Spanning Tree Protocol) is enabled, this field displays the STP state of the port. (See <a href="#">Section 10.1.3 on page 92</a> for more information.) If STP is disabled, this field displays <b>FORWARDING</b> if the link is up, otherwise, it displays <b>STOP</b> .
LACP	This field displays whether LACP (Link Aggregation Control Protocol) has been enabled on the port.
TxPkts	This field shows the number of transmitted frames on this port.
RxPkts	This field shows the number of received frames on this port.
Errors	This field shows the number of received errors on this port.
Tx KB/s	This field shows the transmission speed of data sent on this port in kilobytes per second.
Rx KB/s	This field shows the transmission speed of data received on this port in kilobytes per second.
Up Time	This field shows the total amount of time in hours, minutes and seconds the port has been up.
Clear Counter	Type a port number, select <b>Port</b> and then click <b>Clear Counter</b> to erase the recorded statistical information for that port, or select <b>Any</b> to clear statistics for all ports.

### 6.2.1 Status: Port Details

Click a number in the **Port** column in the **Status** screen to display individual port statistics. Use this screen to check status and detailed performance data about an individual port on the Switch.

Figure 23 Status: Port Details

Port Details		Port Status
Port Info	Port NO.	1
	Name	
	Link	Down
	Status	STOP
	LACP	Disabled
	TxPkts	0
	RxPkts	0
	Errors	0
	Tx KBs/s	0.0
	Rx KBs/s	0.0
	Up Time	0:00:00
<b>TX Packet</b>	<b>TX Packets</b>	<b>0</b>
	Multicast	0
	Broadcast	0
	Pause	0
	Tagged	0
<b>RX Packet</b>	<b>RX Packets</b>	<b>0</b>
	Multicast	0
	Broadcast	0
	Pause	0
	Control	0
<b>TX Collision</b>	<b>Single</b>	<b>0</b>
	Multiple	0
	Excessive	0
	Late	0
<b>Error Packet</b>	<b>RX CRC</b>	<b>0</b>
	Length	0
	Runt	0
<b>Distribution</b>	<b>64</b>	<b>0</b>
	65 to 127	0
	128 to 255	0
	256 to 511	0
	512 to 1023	0
	1024 to 1518	0
	Giant	0

The following table describes the labels in this screen.

Table 7 Status &gt; Port Details

LABEL	DESCRIPTION
Port Info	
Port NO.	This field displays the port number you are viewing.
Name	This field displays the name of the port.
Link	This field displays the speed (either <b>10M</b> for 10Mbps, <b>100M</b> for 100Mbps, <b>1000M</b> for 1000 Mbps, and <b>10G</b> for 10 Gbps) and the duplex ( <b>F</b> for full duplex or <b>H</b> for half duplex). It also shows the cable type ( <b>Copper</b> or <b>Fiber</b> ).
State	If STP (Spanning Tree Protocol) is enabled, this field displays the STP state of the port. (See <a href="#">Section 10.1.3 on page 92</a> for more information.) If STP is disabled, this field displays <b>FORWARDING</b> if the link is up, otherwise, it displays <b>STOP</b> .
LACP	This field shows if LACP is enabled on this port or not.
TxPkts	This field shows the number of transmitted frames on this port
RxPkts	This field shows the number of received frames on this port
Errors	This field shows the number of received errors on this port.
Tx KB/s	This field shows the transmission speed of data sent on this port in kilobytes per second.

**Table 7** Status > Port Details (continued)

<b>LABEL</b>	<b>DESCRIPTION</b>
Rx KB/s	This field shows the transmission speed of data received on this port in kilobytes per second.
Up Time	This field shows the total amount of time the connection has been up.
Tx Packet The following fields display detailed information about packets transmitted.	
TX Packets	This field shows the number of good packets (unicast, multicast and broadcast) transmitted.
Multicast	This field shows the number of good multicast packets transmitted.
Broadcast	This field shows the number of good broadcast packets transmitted.
Pause	This field shows the number of 802.3x Pause packets transmitted.
Tagged	This field shows the number of packets with VLAN tags transmitted.
Rx Packet The following fields display detailed information about packets received.	
RX Packets	This field shows the number of good packets (unicast, multicast and broadcast) received.
Multicast	This field shows the number of good multicast packets received.
Broadcast	This field shows the number of good broadcast packets received.
Pause	This field shows the number of 802.3x Pause packets received.
Control	This field shows the number of control packets received (including those with CRC error) but it does not include the 802.3x Pause packets.
TX Collision The following fields display information on collisions while transmitting.	
Single	This is a count of successfully transmitted packets for which transmission is inhibited by exactly one collision.
Multiple	This is a count of successfully transmitted packets for which transmission was inhibited by more than one collision.
Excessive	This is a count of packets for which transmission failed due to excessive collisions. Excessive collision is defined as the number of maximum collisions before the retransmission count is reset.
Late	This is the number of times a late collision is detected, that is, after 512 bits of the packets have already been transmitted.
Error Packet The following fields display detailed information about packets received that were in error.	
RX CRC	This field shows the number of packets received with CRC (Cyclic Redundant Check) error(s).
Length	This field shows the number of packets received with a length that was out of range.
Runt	This field shows the number of packets received that were too short (shorter than 64 octets), including the ones with CRC errors.
Distribution	
64	This field shows the number of packets (including bad packets) received that were 64 octets in length.
65-127	This field shows the number of packets (including bad packets) received that were between 65 and 127 octets in length.
128-255	This field shows the number of packets (including bad packets) received that were between 128 and 255 octets in length.

**Table 7** Status > Port Details (continued)

<b>LABEL</b>	<b>DESCRIPTION</b>
256-511	This field shows the number of packets (including bad packets) received that were between 256 and 511 octets in length.
512-1023	This field shows the number of packets (including bad packets) received that were between 512 and 1023 octets in length.
1024-1518	This field shows the number of packets (including bad packets) received that were between 1024 and 1518 octets in length.
Giant	This field shows the number of packets dropped because they were bigger than the maximum frame size.



# Basic Setting

This chapter describes how to configure the **System Info**, **General Setup**, **Switch Setup**, **IP Setup** and **Port Setup** screens.

## 7.1 Overview

The **System Info** screen displays general Switch information (such as firmware version number) and hardware polling information (such as fan speeds). The **General Setup** screen allows you to configure general Switch identification information. The **General Setup** screen also allows you to set the system time manually or get the current time and date from an external server when you turn on your Switch. The real time is then displayed in the Switch logs. The **Switch Setup** screen allows you to set up and configure global Switch features. The **IP Setup** screen allows you to configure a Switch IP address in each routing domain, subnet mask(s) and DNS (domain name server) for management purposes.

## 7.2 System Information

In the navigation panel, click **Basic Setting** > **System Info** to display the screen as shown. You can check the firmware version number and monitor the Switch temperature, fan speeds and voltage in this screen.

**Figure 24** Basic Setting > System Info

System Info					
System Name	GS-2024				
ZyNOS F/W Version	V3.80(LT.0)b1   09/14/2007				
Ethernet Address	00:a0:c5:01:23:46				
Hardware Monitor					
Temperature Unit	C				
Temperature (C)	Current	MAX	MIN	Threshold	Status
MAC	37.5	41.0	29.0	65.0	Normal
CPU	33.0	35.0	27.0	65.0	Normal
PHY	32.5	35.5	27.5	65.0	Normal
FAN Speed (RPM)	Current	MAX	MIN	Threshold	Status
FAN1	5810	6061	5763	4500	Normal
FAN2	5859	6061	5810	4500	Normal
Voltage (V)	Current	MAX	MIN	Threshold	Status
VCOREA	2.544	2.544	2.528	+/-5%	Normal
VINRO	1.264	1.264	1.264	+/-10%	Normal
3.3VIN	3.376	3.376	3.376	+/-5%	Normal
12VIN	11.977	12.220	11.977	+/-10%	Normal
1.3VIN	1.312	1.312	1.312	+/-10%	Normal
1.8VIN	1.888	1.888	1.888	+/-10%	Normal

The following table describes the labels in this screen.

**Table 8** Basic Setting > System Info

LABEL	DESCRIPTION
System Name	This field displays the descriptive name of the Switch for identification purposes.
ZyNOS F/W Version	This field displays the version number of the Switch 's current firmware including the date created.
Ethernet Address	This field refers to the Ethernet MAC (Media Access Control) address of the Switch.
Hardware Monitor	
Temperature Unit	The Switch has temperature sensors that are capable of detecting and reporting if the temperature rises above the threshold. You may choose the temperature unit (Centigrade or Fahrenheit) in this field.
Temperature	<b>CPU, PHY, and MAC</b> refer to the location of the temperature sensors on the Switch printed circuit board.
Current	This shows the current temperature at this sensor.
MAX	This field displays the maximum temperature measured at this sensor.
MIN	This field displays the minimum temperature measured at this sensor.
Threshold	This field displays the upper temperature limit at this sensor.
Status	This field displays <b>Normal</b> for temperatures below the threshold and <b>Error</b> for those above.
Fan Speed (RPM)	A properly functioning fan is an essential component (along with a sufficiently ventilated, cool operating environment) in order for the device to stay within the temperature threshold. Each fan has a sensor that is capable of detecting and reporting if the fan speed falls below the threshold shown.
Current	This field displays this fan's current speed in Revolutions Per Minute (RPM).
MAX	This field displays this fan's maximum speed measured in RPM.

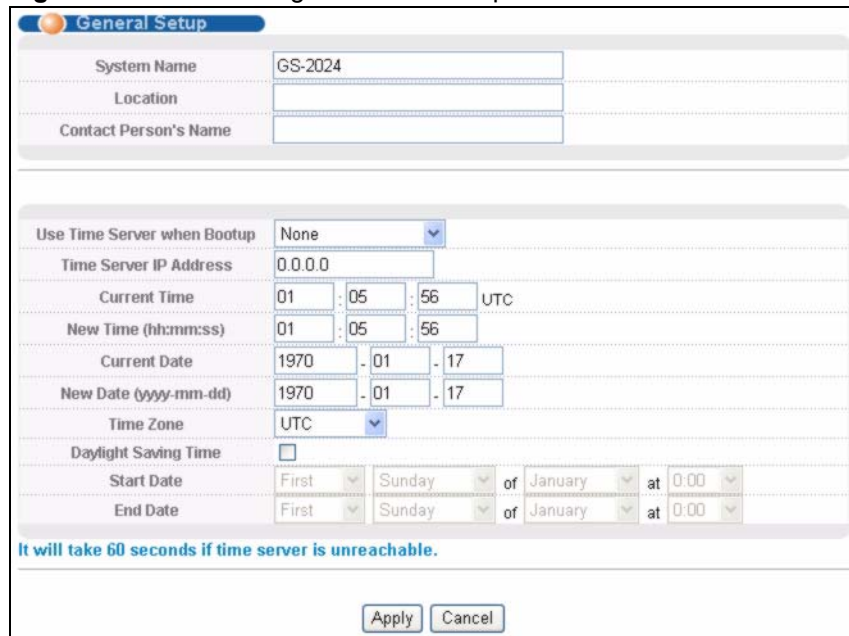

**Table 8** Basic Setting > System Info (continued)

LABEL	DESCRIPTION
MIN	This field displays this fan's minimum speed measured in RPM. "<41" is displayed for speeds too small to measure (under 2000 RPM).
Threshold	This field displays the minimum speed at which a normal fan should work.
Status	<b>Normal</b> indicates that this fan is functioning above the minimum speed. <b>Error</b> indicates that this fan is functioning below the minimum speed.
Voltage (V)	The power supply for each voltage has a sensor that is capable of detecting and reporting if the voltage falls out of the tolerance range.
Current	This is the current voltage reading.
MAX	This field displays the maximum voltage measured at this point.
MIN	This field displays the minimum voltage measured at this point.
Threshold	This field displays the percentage tolerance of the voltage with which the Switch still works.
Status	<b>Normal</b> indicates that the voltage is within an acceptable operating range at this point; otherwise <b>Error</b> is displayed.

## 7.3 General Setup

Use this screen to configure general settings such as the system name and time. Click **Basic Setting** and **General Setup** in the navigation panel to display the screen as shown.

**Figure 25** Basic Setting > General Setup

**General Setup**

System Name: GS-2024

Location:

Contact Person's Name:

Use Time Server when Bootup: None

Time Server IP Address: 0.0.0.0

Current Time: 01 : 05 : 56 UTC

New Time (hh:mm:ss): 01 : 05 : 56

Current Date: 1970 - 01 - 17

New Date (yyyy-mm-dd): 1970 - 01 - 17

Time Zone: UTC

Daylight Saving Time:

Start Date: First Sunday of January at 0:00

End Date: First Sunday of January at 0:00

It will take 60 seconds if time server is unreachable.

Apply Cancel

The following table describes the labels in this screen.

**Table 9** Basic Setting > General Setup

LABEL	DESCRIPTION
System Name	Type a descriptive name for identification purposes. This name consists of up to 64 printable characters; spaces are allowed.
Location	Type the geographic location of your Switch. You can use up to 32 printable ASCII characters; spaces are allowed.
Contact Person's Name	Type the name of the person in charge of this Switch. You can use up to 32 printable ASCII characters; spaces are allowed.
Use Time Server when Bootup	<p>Type the time service protocol that your timeserver uses. Not all time servers support all protocols, so you may have to use trial and error to find a protocol that works. The main differences between them are the time format.</p> <p>When you select the <b>Daytime (RFC 867)</b> format, the Switch displays the day, month, year and time with no time zone adjustment. When you use this format, it is recommended that you use a Daytime timeserver within your geographical time zone.</p> <p><b>Time (RFC-868)</b> format displays a 4-byte integer giving the total number of seconds since 1970/1/1 at 0:0:0.</p> <p><b>NTP (RFC-1305)</b> is similar to Time (RFC-868).</p> <p><b>None</b> is the default value. Enter the time manually. Each time you turn on the Switch, the time and date will be reset to 1970-1-1 0:0.</p>
Time Server IP Address	Type the IP address of your timeserver. The Switch searches for the timeserver for up to 60 seconds. If you select a timeserver that is unreachable, then this screen will appear locked for 60 seconds. Please wait.
Current Time	This field displays the time you open this menu (or refresh the menu).
New Time (hh:min:ss)	Enter the new time in hour, minute and second format. The new time then appears in the <b>Current Time</b> field after you click <b>Apply</b> .
Current Date	This field displays the date you open this menu.
New Date (yyyy-mm-dd)	Enter the new date in year, month and day format. The new date then appears in the <b>Current Date</b> field after you click <b>Apply</b> .
Time Zone	Select the time difference between UTC (Universal Time Coordinated, formerly known as GMT, Greenwich Mean Time) and your time zone from the drop-down list box.
Daylight Saving Time	<p>Daylight saving is a period from late spring to early fall when many countries set their clocks ahead of normal local time by one hour to give more daytime light in the evening.</p> <p>Select this option if you use Daylight Saving Time.</p>
Start Date	<p>Configure the day and time when Daylight Saving Time starts if you selected <b>Daylight Saving Time</b>. The time is displayed in the 24 hour format. Here are a couple of examples:</p> <p>Daylight Saving Time starts in most parts of the United States on the second Sunday of March. Each time zone in the United States starts using Daylight Saving Time at 2 A.M. local time. So in the United States you would select <b>Second, Sunday, March</b> and <b>2:00</b>.</p> <p>Daylight Saving Time starts in the European Union on the last Sunday of March. All of the time zones in the European Union start using Daylight Saving Time at the same moment (1 A.M. GMT or UTC). So in the European Union you would select <b>Last, Sunday, March</b> and the last field depends on your time zone. In Germany for instance, you would select <b>2:00</b> because Germany's time zone is one hour ahead of GMT or UTC (GMT+1).</p>

**Table 9** Basic Setting > General Setup (continued)

LABEL	DESCRIPTION
End Date	Configure the day and time when Daylight Saving Time ends if you selected <b>Daylight Saving Time</b> . The time field uses the 24 hour format. Here are a couple of examples: Daylight Saving Time ends in the United States on the last Sunday of October. Each time zone in the United States stops using Daylight Saving Time at 2 A.M. local time. So in the United States you would select <b>First, Sunday, November</b> and <b>2:00</b> . Daylight Saving Time ends in the European Union on the last Sunday of October. All of the time zones in the European Union stop using Daylight Saving Time at the same moment (1 A.M. GMT or UTC). So in the European Union you would select <b>Last, Sunday, October</b> and the last field depends on your time zone. In Germany for instance, you would select <b>2:00</b> because Germany's time zone is one hour ahead of GMT or UTC (GMT+1).
Apply	Click <b>Apply</b> to save your changes to the Switch's run-time memory. The Switch loses these changes if it is turned off or loses power, so use the <b>Save</b> link on the top navigation panel to save your changes to the non-volatile memory when you are done configuring.
Cancel	Click <b>Cancel</b> to begin configuring this screen afresh.

## 7.4 Introduction to VLANs

A VLAN (Virtual Local Area Network) allows a physical network to be partitioned into multiple logical networks. Devices on a logical network belong to one group. A device can belong to more than one group. With VLAN, a device cannot directly talk to or hear from devices that are not in the same group(s); the traffic must first go through a router.

In MTU (Multi-Tenant Unit) applications, VLAN is vital in providing isolation and security among the subscribers. When properly configured, VLAN prevents one subscriber from accessing the network resources of another on the same LAN, thus a user will not see the printers and hard disks of another user on the same network.

VLAN also increases network performance by limiting broadcasts to a smaller and more manageable logical broadcast domain. In traditional switched environments, all broadcast packets go to each and every individual port. With VLAN, all broadcasts are confined to a specific broadcast domain.



---

VLAN is unidirectional; it only governs outgoing traffic.

---

See [Chapter 8 on page 77](#) for information on port-based and 802.1Q tagged VLANs.

## 7.5 Switch Setup Screen

Click **Basic Setting** and then **Switch Setup** in the navigation panel to display the screen as shown. The VLAN setup screens change depending on whether you choose **802.1Q** or **Port Based** in the **VLAN Type** field in this screen. Refer to the chapter on VLAN.

Figure 26 Basic Setting &gt; Switch Setup

VLAN Type	
<input checked="" type="radio"/>	802.1Q
<input type="radio"/>	Port Based

MAC Address Learning	
Aging Time	300 seconds
Join Timer	200 milliseconds

GARP Timer	
Leave Timer	600 milliseconds
Leave All Timer	10000 milliseconds

Priority Queue Assignment	
level7	3
level6	3
level5	2
level4	2
level3	1
level2	0
level1	0
level0	1

The following table describes the labels in this screen.

Table 10 Basic Setting &gt; Switch Setup

LABEL	DESCRIPTION
VLAN Type	Choose <b>802.1Q</b> or <b>Port Based</b> . The <b>VLAN Setup</b> screen changes depending on whether you choose <b>802.1Q</b> VLAN type or <b>Port Based</b> VLAN type in this screen. See <a href="#">Chapter 8 on page 77</a> for more information.
MAC Address Learning	MAC address learning reduces outgoing traffic broadcasts. For MAC address learning to occur on a port, the port must be active.
Aging Time	Enter a time from 10 to 3000 seconds. This is how long all dynamically learned MAC addresses remain in the MAC address table before they age out (and must be relearned).
GARP Timer: Switches join VLANs by making a declaration. A declaration is made by issuing a <b>Join</b> message using GARP. Declarations are withdrawn by issuing a <b>Leave</b> message. A <b>Leave All</b> message terminates all registrations. GARP timers set declaration timeout values. See <a href="#">Chapter 8 on page 77</a> for more background information.	
Join Timer	Join Timer sets the duration of the <b>Join Period</b> timer for GVRP in milliseconds. Each port has a <b>Join Period</b> timer. The allowed <b>Join Time</b> range is between 100 and 65535 milliseconds; the default is 200 milliseconds. See <a href="#">Chapter 8 on page 77</a> for more background information.
Leave Timer	Leave Time sets the duration of the <b>Leave Period</b> timer for GVRP in milliseconds. Each port has a single <b>Leave Period</b> timer. Leave Time must be two times larger than <b>Join Timer</b> ; the default is 600 milliseconds.
Leave All Timer	Leave All Timer sets the duration of the <b>Leave All Period</b> timer for GVRP in milliseconds. Each port has a single <b>Leave All Period</b> timer. Leave All Timer must be larger than Leave Timer.
<p>Priority Queue Assignment</p> <p>IEEE 802.1p defines up to eight separate traffic types by inserting a tag into a MAC-layer frame that contains bits to define class of service. Frames without an explicit priority tag are given the default priority of the ingress port. Use the following fields to configure the priority level-to-physical queue mapping.</p> <p>The Switch has four physical queues that you can map to the eight priority levels. On the Switch, traffic assigned to higher index queues gets through faster while traffic in lower index queues is dropped if the network is congested.</p>	

**Table 10** Basic Setting > Switch Setup (continued)

LABEL	DESCRIPTION
Priority Level (The following descriptions are based on the traffic types defined in the IEEE 802.1d standard (which incorporates the 802.1p).	
Level 7	Typically used for network control traffic such as router configuration messages.
Level 6	Typically used for voice traffic that is especially sensitive to jitter (jitter is the variations in delay).
Level 5	Typically used for video that consumes high bandwidth and is sensitive to jitter.
Level 4	Typically used for controlled load, latency-sensitive traffic such as SNA (Systems Network Architecture) transactions.
Level 3	Typically used for “excellent effort” or better than best effort and would include important business traffic that can tolerate some delay.
Level 2	This is for “spare bandwidth”.
Level 1	This is typically used for non-critical “background” traffic such as bulk transfers that are allowed but that should not affect other applications and users.
Level 0	Typically used for best-effort traffic.
Apply	Click <b>Apply</b> to save your changes to the Switch’s run-time memory. The Switch loses these changes if it is turned off or loses power, so use the <b>Save</b> link on the top navigation panel to save your changes to the non-volatile memory when you are done configuring.
Cancel	Click <b>Cancel</b> to begin configuring this screen afresh.

## 7.6 IP Setup

Use the **IP Setup** screen to configure the default gateway device, the default domain name server and add IP domains.

### 7.6.1 IP Interfaces

The Switch needs an IP address for it to be managed over the network. The factory default IP address is 192.168.1.1. The subnet mask specifies the network number portion of an IP address. The factory default subnet mask is 255.255.255.0.

You can configure multiple IP addresses which are used to access and manage the Switch from the ports belonging to the pre-defined VLAN(s).



---

You must configure the VLAN first.

---

**Figure 27** Basic Setting > IP Setup

IP Setup

Domain Name Server

Default Management  In-band  Out-of-band

---

**In-band Management IP Address**

DHCP Client

Static IP Address

IP Address

IP Subnet Mask

Default Gateway

VID

---

**Out-of-band Management IP Address**

IP Address

IP Subnet Mask

Default Gateway

---

**In-band IP Addresses**

IP Address	<input style="width: 100%;" type="text" value="0.0.0.0"/>
IP Subnet Mask	<input style="width: 100%;" type="text" value="0.0.0.0"/>
VID	<input style="width: 100%;" type="text"/>
Default Gateway	<input style="width: 100%;" type="text" value="0.0.0.0"/>

---

Index	IP Address	IP Subnet Mask	VID	Default Gateway	Delete

The following table describes the labels in this screen.

**Table 11** Basic Setting > IP Setup

LABEL	DESCRIPTION
Domain Name Server	This field is enabled if <b>Static IP Address</b> is selected. DNS (Domain Name System) is for mapping a domain name to its corresponding IP address and vice versa. Enter a domain name server IP address in order to be able to use a domain name instead of an IP address.
Default Management	Specify which traffic flow (In-Band or Out-of-band) the Switch is to send packets originating from itself (such as SNMP traps) or packets with unknown source. Select <b>Out-of-band</b> to have the Switch send the packets to the out-of-band management port. This means that device(s) connected to the other port(s) do not receive these packets. Select <b>In-Band</b> to have the Switch send the packets to all ports except the out-of-band management port to which connected device(s) do not receive these packets.
In-band Management IP Address	
DHCP Client	Select this option if you have a DHCP server that can assign the Switch an IP address, subnet mask, a default gateway IP address and a domain name server IP address automatically.
Static IP Address	Select this option if you don't have a DHCP server or if you wish to assign static IP address information to the Switch. You need to fill in the following fields and <b>Domain Name Server</b> when you select this option.
IP Address	Enter the IP address of your Switch in dotted decimal notation for example 192.168.1.1.
IP Subnet Mask	Enter the IP subnet mask of your Switch in dotted decimal notation for example 255.255.255.0.
Default Gateway	Enter the IP address of the default outgoing gateway in dotted decimal notation, for example 192.168.1.254.
VID	Enter the VLAN identification number associated with the Switch IP address. VID is the VLAN ID of the CPU and is used for management only. The default is "1". All ports, by default, are fixed members of this "management VLAN" in order to manage the device from any port. If a port is not a member of this VLAN, then users on that port cannot access the device. To access the Switch make sure the port that you are connected to is a member of Management VLAN.
Out-of-band Management IP Address	
IP Address	Enter the IP address of your Switch in dotted decimal notation for example 192.168.0.1. If you change this IP address, make sure the computer connected to this management port is in the same subnet before accessing the Switch.
IP Subnet Mask	Enter the IP subnet mask of your Switch in dotted decimal notation for example 255.255.255.0.
Default Gateway	Enter the IP address of the default outgoing gateway in dotted decimal notation, for example 192.168.0.254.
Apply	Click <b>Apply</b> to save your changes to the Switch's run-time memory. The Switch loses these changes if it is turned off or loses power, so use the <b>Save</b> link on the top navigation panel to save your changes to the non-volatile memory when you are done configuring.
Cancel	Click <b>Cancel</b> to reset the fields.
In-band IP Addresses	You can create IP addresses, which are used to access and manage the Switch from the ports belonging to the pre-defined VLAN(s). You must configure a VLAN first.

**Table 11** Basic Setting > IP Setup (continued)

LABEL	DESCRIPTION
IP Address	Enter the IP address for managing the Switch by the members of the VLAN specified in the <b>VID</b> field below.
IP Subnet Mask	Enter the IP subnet mask in dotted decimal notation.
VID	Type the VLAN group identification number.
Default Gateway	Enter the IP address of the default outgoing gateway in dotted decimal notation.
Add	Click <b>Add</b> to save the new rule to the Switch's run-time memory. It then displays in the summary table at the bottom of the screen.
Cancel	Click <b>Cancel</b> to reset the fields.
Index	This field displays the index number of an entry. Click an index number to edit the rule.
IP Address	This field displays the IP address.
IP Subnet Mask	This field displays the subnet mask.
VID	This field displays the VLAN identification number of the network.
Default Gateway	This field displays the IP address of the default outgoing gateway.
Manageable	This field displays whether the Switch can be managed using the specified IP address.
Delete	Click <b>Delete</b> to remove the selected entry from the summary table.
Cancel	Click <b>Cancel</b> to clear the <b>Delete</b> check boxes.

## 7.7 Port Setup

Use this screen to configure Switch port settings. Click **Basic Setting > Port Setup** in the navigation panel to display the configuration screen.

**Figure 28** Basic Setting > Port Setup

The screenshot shows the 'Port Setup' configuration screen. At the top, there is a title bar with a blue 'Port Setup' button. Below it is a table with the following columns: Port, Active, Name, Type, Speed / Duplex, Flow Control, 802.1p Priority, and Jumbo Frame. The table contains 8 rows, with the first row marked with an asterisk (\*) and the remaining rows numbered 1 through 7. Each row has a checkbox in the 'Active' column, which is checked for all ports. The 'Name' column is empty for all ports. The 'Type' column shows '10/100/1000M' for ports 1-7 and '-' for the asterisk row. The 'Speed / Duplex' column shows 'Auto' for all ports. The 'Flow Control' column has a checkbox that is unchecked for all ports. The '802.1p Priority' column has a dropdown menu set to '0' for all ports. The 'Jumbo Frame' column has a checkbox that is unchecked for all ports. At the bottom of the screen, there are 'Apply' and 'Cancel' buttons.

Port	Active	Name	Type	Speed / Duplex	Flow Control	802.1p Priority	Jumbo Frame
*	<input type="checkbox"/>		-	Auto	<input type="checkbox"/>	0	<input type="checkbox"/>
1	<input checked="" type="checkbox"/>		10/100/1000M	Auto	<input type="checkbox"/>	0	<input type="checkbox"/>
2	<input checked="" type="checkbox"/>		10/100/1000M	Auto	<input type="checkbox"/>	0	<input type="checkbox"/>
3	<input checked="" type="checkbox"/>		10/100/1000M	Auto	<input type="checkbox"/>	0	<input type="checkbox"/>
4	<input checked="" type="checkbox"/>		10/100/1000M	Auto	<input type="checkbox"/>	0	<input type="checkbox"/>
5	<input checked="" type="checkbox"/>		10/100/1000M	Auto	<input type="checkbox"/>	0	<input type="checkbox"/>
6	<input checked="" type="checkbox"/>		10/100/1000M	Auto	<input type="checkbox"/>	0	<input type="checkbox"/>
7	<input checked="" type="checkbox"/>		10/100/1000M	Auto	<input type="checkbox"/>	0	<input type="checkbox"/>



The following table describes the labels in this screen.

**Table 12** Basic Setting > Port Setup

LABEL	DESCRIPTION
Port	This is the port index number.
*	<p>Settings in this row apply to all ports. Use this row only if you want to make some settings the same for all ports. Use this row first to set the common settings and then make adjustments on a port-by-port basis.</p> <p><b>Note:</b> Changes in this row are copied to all the ports as soon as you make them.</p>
Active	Select this check box to enable a port. The factory default for all ports is enabled. A port must be enabled for data transmission to occur.
Name	<p>Type a descriptive name that identifies this port. You can enter up to 64 alpha-numerical characters.</p> <p><b>Note:</b> Due to space limitations, the port name may be truncated in some web configurator screens.</p>
Type	This field displays <b>10/100/1000M</b> for a 1000Base-T connection.
Speed/Duplex	<p>Select the speed and the duplex mode of the Ethernet connection on this port. The choices are <b>Auto</b>, <b>10M/Half Duplex</b>, <b>10M/Full Duplex</b>, <b>100M/Half Duplex</b> and <b>100M/Full Duplex</b> for a 1000Base-T connection. <b>1000M/Full Duplex</b> is supported by both 1000Base-T and 1000Base-X connections.</p> <p>Selecting <b>Auto</b> (auto-negotiation) allows one port to negotiate with a peer port automatically to obtain the connection speed and duplex mode that both ends support. When auto-negotiation is turned on, a port on the Switch negotiates with the peer automatically to determine the connection speed and duplex mode. If the peer port does not support auto-negotiation or turns off this feature, the Switch determines the connection speed by detecting the signal on the cable and using half duplex mode. When the Switch's auto-negotiation is turned off, a port uses the pre-configured speed and duplex mode when making a connection, thus requiring you to make sure that the settings of the peer port are the same in order to connect.</p>
Flow Control	<p>A concentration of traffic on a port decreases port bandwidth and overflows buffer memory causing packet discards and frame losses. <b>Flow Control</b> is used to regulate transmission of signals to match the bandwidth of the receiving port.</p> <p>The Switch uses IEEE 802.3x flow control in full duplex mode and backpressure flow control in half duplex mode.</p> <p>IEEE 802.3x flow control is used in full duplex mode to send a pause signal to the sending port, causing it to temporarily stop sending signals when the receiving port memory buffers fill.</p> <p>Back Pressure flow control is typically used in half duplex mode to send a "collision" signal to the sending port (mimicking a state of packet collision) causing the sending port to temporarily stop sending signals and resend later. Select <b>Flow Control</b> to enable it.</p>
802.1p Priority	This priority value is added to incoming frames without a (802.1p) priority queue tag. See <b>Priority Queue Assignment</b> in <a href="#">Table 10 on page 68</a> for more information.
Jumbo Frame	Jumbo frames are Ethernet frames with a payload greater than 1500 bytes. Select this if you want this port to accept jumbo frames. Clear this if you want this port to discard jumbo frames.
Apply	Click <b>Apply</b> to save your changes to the Switch's run-time memory. The Switch loses these changes if it is turned off or loses power, so use the <b>Save</b> link on the top navigation panel to save your changes to the non-volatile memory when you are done configuring.
Cancel	Click <b>Cancel</b> to begin configuring this screen afresh.



---

# PART III

## Advanced Setup

---

VLAN (77)  
Static MAC Forward Setup (89)  
Spanning Tree Protocol (91)  
Bandwidth Control (105)  
Broadcast Storm Control (107)  
Mirroring (109)  
Link Aggregation (111)  
Port Authentication (117)  
Port Security (121)  
Queuing Method (123)  
Multicast (125)  
Authentication & Accounting (139)  
Loop Guard (153)



The type of screen you see here depends on the **VLAN Type** you selected in the **Switch Setup** screen. This chapter shows you how to configure 802.1Q tagged and port-based VLANs.

## 8.1 Introduction to IEEE 802.1Q Tagged VLANs

A tagged VLAN uses an explicit tag (VLAN ID) in the MAC header to identify the VLAN membership of a frame across bridges - they are not confined to the switch on which they were created. The VLANs can be created statically by hand or dynamically through GVRP. The VLAN ID associates a frame with a specific VLAN and provides the information that switches need to process the frame across the network. A tagged frame is four bytes longer than an untagged frame and contains two bytes for the TPID (Tag Protocol Identifier, residing within the type/length field of the Ethernet frame) and two bytes for the TCI (Tag Control Information, starting after the source address field of the Ethernet frame).

The CFI (Canonical Format Indicator) is a single-bit flag, always set to zero for Ethernet switches. If a frame received at an Ethernet port has a CFI set to 1, then that frame should not be forwarded as it is to an untagged port. The remaining twelve bits define the VLAN ID, giving a possible maximum number of 4,096 VLANs. Note that user priority and VLAN ID are independent of each other. A frame with VID (VLAN Identifier) of null (0) is called a priority frame, meaning that only the priority level is significant and the default VID of the ingress port is given as the VID of the frame. Of the 4096 possible VIDs, a VID of 0 is used to identify priority frames and the value 4095 (FFF) is reserved, so the maximum possible number of VLAN configurations is 4,094.

TPID	User Priority	CFI	VLAN ID
2 Bytes	3 Bits	1 Bit	12 bits

### 8.1.1 Forwarding Tagged and Untagged Frames

Each port on the Switch is capable of passing tagged or untagged frames. To forward a frame from an 802.1Q VLAN-aware switch to an 802.1Q VLAN-unaware switch, the Switch first decides where to forward the frame and then strips off the VLAN tag. To forward a frame from an 802.1Q VLAN-unaware switch to an 802.1Q VLAN-aware switch, the Switch first decides where to forward the frame, and then inserts a VLAN tag reflecting the ingress port's default VID. The default PVID is VLAN 1 for all ports, but this can be changed.

A broadcast frame (or a multicast frame for a multicast group that is known by the system) is duplicated only on ports that are members of the VID (except the ingress port itself), thus confining the broadcast to a specific domain.

## 8.2 Automatic VLAN Registration

GARP and GVRP are the protocols used to automatically register VLAN membership across switches.

### 8.2.1 GARP

GARP (Generic Attribute Registration Protocol) allows network switches to register and de-register attribute values with other GARP participants within a bridged LAN. GARP is a protocol that provides a generic mechanism for protocols that serve a more specific application, for example, GVRP.

#### 8.2.1.1 GARP Timers

Switches join VLANs by making a declaration. A declaration is made by issuing a Join message using GARP. Declarations are withdrawn by issuing a Leave message. A Leave All message terminates all registrations. GARP timers set declaration timeout values.

### 8.2.2 GVRP

GVRP (GARP VLAN Registration Protocol) is a registration protocol that defines a way for switches to register necessary VLAN members on ports across the network. Enable this function to permit VLAN groups beyond the local Switch.

Please refer to the following table for common IEEE 802.1Q VLAN terminology.

**Table 13** IEEE 802.1Q VLAN Terminology

VLAN PARAMETER	TERM	DESCRIPTION
VLAN Type	Permanent VLAN	This is a static VLAN created manually.
	Dynamic VLAN	This is a VLAN configured by a GVRP registration/deregistration process.
VLAN Administrative Control	Registration Fixed	Fixed registration ports are permanent VLAN members.
	Registration Forbidden	Ports with registration forbidden are forbidden to join the specified VLAN.
	Normal Registration	Ports dynamically join a VLAN using GVRP.
VLAN Tag Control	Tagged	Ports belonging to the specified VLAN tag all outgoing frames transmitted.
	Untagged	Ports belonging to the specified VLAN don't tag all outgoing frames transmitted.
VLAN Port	Port VID	This is the VLAN ID assigned to untagged frames that this port received.
	Acceptable Frame Type	You may choose to accept both tagged and untagged incoming frames, just tagged incoming frames or just untagged incoming frames on a port.
	Ingress filtering	If set, the Switch discards incoming frames for VLANs that do not have this port as a member.

## 8.3 Port VLAN Trunking

Enable **VLAN Trunking** on a port to allow frames belonging to unknown VLAN groups to pass through that port. This is useful if you want to set up VLAN groups on end devices without having to configure the same VLAN groups on intermediary devices.

The following figure describes **VLAN Trunking**. Suppose you want to create VLAN groups 1 and 2 (V1 and V2) on devices A and B. Without **VLAN Trunking**, you must configure VLAN groups 1 and 2 on all intermediary switches C, D and E; otherwise they will drop frames with unknown VLAN group tags. However, with **VLAN Trunking** enabled on a port(s) in each intermediary switch you only need to create VLAN groups in the end devices (A and B). C, D and E automatically allow frames with VLAN group tags 1 and 2 (VLAN groups that are unknown to those switches) to pass through their VLAN trunking port(s).

**Figure 29** Port VLAN Trunking

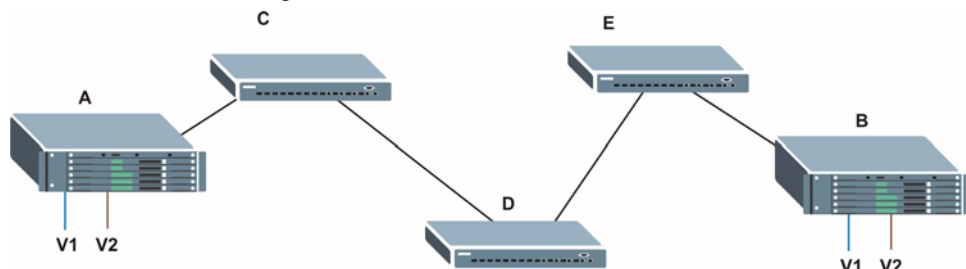

## 8.4 Select the VLAN Type

Select a VLAN type in the **Basic Setting > Switch Setup** screen.

**Figure 30** Switch Setup: Select VLAN Type

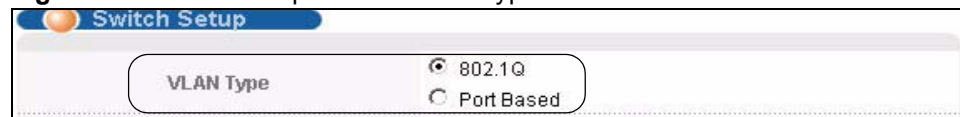

## 8.5 Static VLAN

Use a static VLAN to decide whether an incoming frame on a port should be

- sent to a VLAN group as normal depending on its VLAN tag.
- sent to a group whether it has a VLAN tag or not.
- blocked from a VLAN group regardless of its VLAN tag.

You can also tag all outgoing frames (that were previously untagged) from a port with the specified VID.

## 8.5.1 Static VLAN Status

See [Section 8.1 on page 77](#) for more information on Static VLAN. Click **Advanced Application** > **VLAN** from the navigation panel to display the **VLAN Status** screen as shown next.

**Figure 31** Advanced Application > VLAN: VLAN Status

Index	VID	Elapsed Time	Status
1	1	3:49:44	Static

The following table describes the labels in this screen.

**Table 14** Advanced Application > VLAN: VLAN Status

LABEL	DESCRIPTION
The Number of VLAN	This is the number of VLANs configured on the Switch.
Index	This is the VLAN index number. Click on an index number to view more VLAN details.
VID	This is the VLAN identification number that was configured in the <b>Static VLAN</b> screen.
Elapsed Time	This field shows how long it has been since a normal VLAN was registered or a static VLAN was set up.
Status	This field shows how this VLAN was added to the Switch; <b>dynamic</b> - using GVRP, <b>static</b> - added as a permanent entry or <b>other</b> - added in another way such as via Multicast VLAN Registration (MVR).
Change Pages	Click <b>Previous</b> or <b>Next</b> to show the previous/next screen if all status information cannot be seen in one screen.

## 8.5.2 Static VLAN Details

Use this screen to view detailed port settings and status of the VLAN group. See [Section 8.1 on page 77](#) for more information on static VLAN. Click on an index number in the **VLAN Status** screen to display VLAN details.

**Figure 32** Advanced Application > VLAN > VLAN Detail

VID	Port Number												Elapsed Time	Status
	2	4	6	8	10	12	14	16	18	20	22	24		
1	U	U	U	U	U	U	U	U	U	U	U	U	385:17:46	Static
	U	U	U	U	U	U	U	U	U	U	U			



The following table describes the labels in this screen.

**Table 15** Advanced Application > VLAN > VLAN Detail

LABEL	DESCRIPTION
VLAN Status	Click this to go to the <b>VLAN Status</b> screen.
VID	This is the VLAN identification number that was configured in the <b>Static VLAN</b> screen.
Port Number	This column displays the ports that are participating in a VLAN. A tagged port is marked as <b>T</b> , an untagged port is marked as <b>U</b> and ports not participating in a VLAN are marked as “-”.
Elapsed Time	This field shows how long it has been since a normal VLAN was registered or a static VLAN was set up.
Status	This field shows how this VLAN was added to the Switch; <b>dynamic</b> - using GVRP, <b>static</b> - added as a permanent entry or <b>other</b> - added in another way such as via Multicast VLAN Registration (MVR).

### 8.5.3 Configure a Static VLAN

Use this screen to configure and view 802.1Q VLAN parameters for the Switch. See [Section 8.1 on page 77](#) for more information on static VLAN. To configure a static VLAN, click **Static VLAN** in the **VLAN Status** screen to display the screen as shown next.

**Figure 33** Advanced Application > VLAN > Static VLAN

The screenshot displays the 'Static VLAN' configuration interface. At the top, there is a header 'Static VLAN' and a 'VLAN Status' link. Below the header, there is an 'ACTIVE' checkbox and two input fields: 'Name' and 'VLAN Group ID'. The main section is a table for port configuration with columns: 'Port', 'Control', and 'Tagging'. The 'Control' column has a dropdown menu set to 'Normal'. The 'Tagging' column has a 'Tx Tagging' checkbox checked for each port. Below the table are 'Add', 'Cancel', and 'Clear' buttons. At the bottom, there is a table for VLAN details with columns: 'VID', 'Active', 'Name', and 'Delete'. The table shows one entry with VID '1', Active 'Yes', Name '1', and a 'Delete' checkbox. Below this table are 'Delete' and 'Cancel' buttons.

The following table describes the related labels in this screen.

**Table 16** Advanced Application > VLAN > Static VLAN

LABEL	DESCRIPTION
ACTIVE	Select this check box to activate the VLAN settings.
Name	Enter a descriptive name for the VLAN group for identification purposes. This name consists of up to 64 printable characters; spaces are allowed.
VLAN Group ID	Enter the VLAN ID for this static entry; the valid range is between 1 and 4094.
Port	The port number identifies the port you are configuring.
*	Settings in this row apply to all ports. Use this row only if you want to make some settings the same for all ports. Use this row first to set the common settings and then make adjustments on a port-by-port basis.  <b>Note:</b> Changes in this row are copied to all the ports as soon as you make them.
Control	Select <b>Normal</b> for the port to dynamically join this VLAN group using GVRP. This is the default selection. Select <b>Fixed</b> for the port to be a permanent member of this VLAN group. Select <b>Forbidden</b> if you want to prohibit the port from joining this VLAN group.
Tagging	Select <b>TX Tagging</b> if you want the port to tag all outgoing frames transmitted with this VLAN Group ID.
Add	Click <b>Add</b> to save your changes to the Switch's run-time memory. The Switch loses these changes if it is turned off or loses power, so use the <b>Save</b> link on the top navigation panel to save your changes to the non-volatile memory when you are done configuring.
Cancel	Click <b>Cancel</b> to begin configuring this screen afresh.
Clear	Click <b>Clear</b> to start configuring the screen again.
VID	This field displays the ID number of the VLAN group. Click the number to edit the VLAN settings.
Active	This field indicates whether the VLAN settings are enabled ( <b>Yes</b> ) or disabled ( <b>No</b> ).
Name	This field displays the descriptive name for this VLAN group.
Delete	Click <b>Delete</b> to remove the selected entry from the summary table.
Cancel	Click <b>Cancel</b> to clear the <b>Delete</b> check boxes.

### 8.5.4 Configure VLAN Port Settings

Use the VLAN Port Setting screen to configure the static VLAN (IEEE 802.1Q) settings on a port. See [Section 8.1 on page 77](#) for more information on static VLAN. Click the **VLAN Port Setting** link in the **VLAN Status** screen.

**Figure 34** Advanced Application > VLAN > VLAN Port Setting

Port	Ingress Check	PVID	GVRP	Acceptable Frame Type	VLAN Trunking
*	<input type="checkbox"/>		<input type="checkbox"/>	All	<input type="checkbox"/>
1	<input type="checkbox"/>	1	<input type="checkbox"/>	All	<input type="checkbox"/>
2	<input type="checkbox"/>	1	<input type="checkbox"/>	All	<input type="checkbox"/>
3	<input type="checkbox"/>	1	<input type="checkbox"/>	All	<input type="checkbox"/>
4	<input type="checkbox"/>	1	<input type="checkbox"/>	All	<input type="checkbox"/>
5	<input type="checkbox"/>	1	<input type="checkbox"/>	All	<input type="checkbox"/>
6	<input type="checkbox"/>	1	<input type="checkbox"/>	All	<input type="checkbox"/>
7	<input type="checkbox"/>	1	<input type="checkbox"/>	All	<input type="checkbox"/>

The following table describes the labels in this screen.

**Table 17** Advanced Application > VLAN > VLAN Port Setting

LABEL	DESCRIPTION
GVRP	GVRP (GARP VLAN Registration Protocol) is a registration protocol that defines a way for switches to register necessary VLAN members on ports across the network. Select this check box to permit VLAN groups beyond the local Switch.
Port	This field displays the port number.
*	Settings in this row apply to all ports. Use this row only if you want to make some settings the same for all ports. Use this row first to set the common settings and then make adjustments on a port-by-port basis.  Note: Changes in this row are copied to all the ports as soon as you make them.
Ingress Check	If this check box is selected for a port, the Switch discards incoming frames for VLANs that do not include this port in its member set. Clear this check box to disable ingress filtering.
PVID	Enter a number between 1 and 4094 as the port VLAN ID.
GVRP	Select this check box to allow GVRP on this port.
Acceptable Frame Type	Specify the type of frames allowed on a port. Select <b>All</b> from the drop-down list box to accept all untagged or tagged frames on this port. This is the default setting. Select <b>Tag Only</b> to accept only tagged frames on this port. All untagged frames will be dropped. Select <b>Untag Only</b> to accept only untagged frames on this port. All tagged frames will be dropped.
VLAN Trunking	Enable <b>VLAN Trunking</b> on ports connected to other switches or routers (but not ports directly connected to end users) to allow frames belonging to unknown VLAN groups to pass through the Switch.

**Table 17** Advanced Application > VLAN > VLAN Port Setting (continued)

LABEL	DESCRIPTION
Apply	Click <b>Apply</b> to save your changes to the Switch's run-time memory. The Switch loses these changes if it is turned off or loses power, so use the <b>Save</b> link on the top navigation panel to save your changes to the non-volatile memory when you are done configuring.
Cancel	Click <b>Cancel</b> to begin configuring this screen afresh.

## 8.6 Port-based VLAN Setup

Port-based VLANs are VLANs where the packet forwarding decision is based on the destination MAC address and its associated port.

Port-based VLANs require allowed outgoing ports to be defined for each port. Therefore, if you wish to allow two subscriber ports to talk to each other, for example, between conference rooms in a hotel, you must define the egress (an egress port is an outgoing port, that is, a port through which a data packet leaves) for both ports.

Port-based VLANs are specific only to the Switch on which they were created.



---

When you activate port-based VLAN, the Switch uses a default VLAN ID of 1. You cannot change it.

---



---

In screens (such as **IP Setup**) that require a VID, you must enter 1 as the VID.

---

The port-based VLAN setup screen is shown next. The **CPU** management port forms a VLAN with all Ethernet ports.

### 8.6.1 Configure a Port-based VLAN

Select **Port Based** as the **VLAN Type** in the **Switch Setup** screen and then click **VLAN** from the navigation panel to display the following screen. Select either **All Connected** or **Port Isolated** from the drop-down list depending on your VLAN and VLAN security requirements. If VLAN members need to communicate directly with each other, then select **All Connected**. Select **Port Isolated** if you want to restrict users from communicating directly. Click **Apply** to save your settings.

The following screen shows users on a port-based, all-connected VLAN configuration.

**Figure 35** Advanced Application > VLAN > Port Based VLAN Setup (All Connected)

Port Based VLAN Setup

Setting Wizard All connected Apply

Incoming

	1	2	3	4	5	6	7	8	9	10	11	12	13	14	15	16	17	18	19	20	21	22	23	24	
1	<input checked="" type="checkbox"/>	<input checked="" type="checkbox"/>	<input checked="" type="checkbox"/>	<input checked="" type="checkbox"/>	<input checked="" type="checkbox"/>	<input checked="" type="checkbox"/>	<input checked="" type="checkbox"/>	<input checked="" type="checkbox"/>	<input checked="" type="checkbox"/>	<input checked="" type="checkbox"/>	<input checked="" type="checkbox"/>	<input checked="" type="checkbox"/>	<input checked="" type="checkbox"/>	<input checked="" type="checkbox"/>	<input checked="" type="checkbox"/>	<input checked="" type="checkbox"/>	<input checked="" type="checkbox"/>	<input checked="" type="checkbox"/>	<input checked="" type="checkbox"/>	<input checked="" type="checkbox"/>	<input checked="" type="checkbox"/>	<input checked="" type="checkbox"/>	<input checked="" type="checkbox"/>	<input checked="" type="checkbox"/>	1
2	<input checked="" type="checkbox"/>	<input checked="" type="checkbox"/>	<input checked="" type="checkbox"/>	<input checked="" type="checkbox"/>	<input checked="" type="checkbox"/>	<input checked="" type="checkbox"/>	<input checked="" type="checkbox"/>	<input checked="" type="checkbox"/>	<input checked="" type="checkbox"/>	<input checked="" type="checkbox"/>	<input checked="" type="checkbox"/>	<input checked="" type="checkbox"/>	<input checked="" type="checkbox"/>	<input checked="" type="checkbox"/>	<input checked="" type="checkbox"/>	<input checked="" type="checkbox"/>	<input checked="" type="checkbox"/>	<input checked="" type="checkbox"/>	<input checked="" type="checkbox"/>	<input checked="" type="checkbox"/>	<input checked="" type="checkbox"/>	<input checked="" type="checkbox"/>	<input checked="" type="checkbox"/>	<input checked="" type="checkbox"/>	2
3	<input checked="" type="checkbox"/>	<input checked="" type="checkbox"/>	<input checked="" type="checkbox"/>	<input checked="" type="checkbox"/>	<input checked="" type="checkbox"/>	<input checked="" type="checkbox"/>	<input checked="" type="checkbox"/>	<input checked="" type="checkbox"/>	<input checked="" type="checkbox"/>	<input checked="" type="checkbox"/>	<input checked="" type="checkbox"/>	<input checked="" type="checkbox"/>	<input checked="" type="checkbox"/>	<input checked="" type="checkbox"/>	<input checked="" type="checkbox"/>	<input checked="" type="checkbox"/>	<input checked="" type="checkbox"/>	<input checked="" type="checkbox"/>	<input checked="" type="checkbox"/>	<input checked="" type="checkbox"/>	<input checked="" type="checkbox"/>	<input checked="" type="checkbox"/>	<input checked="" type="checkbox"/>	<input checked="" type="checkbox"/>	3
4	<input checked="" type="checkbox"/>	<input checked="" type="checkbox"/>	<input checked="" type="checkbox"/>	<input checked="" type="checkbox"/>	<input checked="" type="checkbox"/>	<input checked="" type="checkbox"/>	<input checked="" type="checkbox"/>	<input checked="" type="checkbox"/>	<input checked="" type="checkbox"/>	<input checked="" type="checkbox"/>	<input checked="" type="checkbox"/>	<input checked="" type="checkbox"/>	<input checked="" type="checkbox"/>	<input checked="" type="checkbox"/>	<input checked="" type="checkbox"/>	<input checked="" type="checkbox"/>	<input checked="" type="checkbox"/>	<input checked="" type="checkbox"/>	<input checked="" type="checkbox"/>	<input checked="" type="checkbox"/>	<input checked="" type="checkbox"/>	<input checked="" type="checkbox"/>	<input checked="" type="checkbox"/>	<input checked="" type="checkbox"/>	4
5	<input checked="" type="checkbox"/>	<input checked="" type="checkbox"/>	<input checked="" type="checkbox"/>	<input checked="" type="checkbox"/>	<input checked="" type="checkbox"/>	<input checked="" type="checkbox"/>	<input checked="" type="checkbox"/>	<input checked="" type="checkbox"/>	<input checked="" type="checkbox"/>	<input checked="" type="checkbox"/>	<input checked="" type="checkbox"/>	<input checked="" type="checkbox"/>	<input checked="" type="checkbox"/>	<input checked="" type="checkbox"/>	<input checked="" type="checkbox"/>	<input checked="" type="checkbox"/>	<input checked="" type="checkbox"/>	<input checked="" type="checkbox"/>	<input checked="" type="checkbox"/>	<input checked="" type="checkbox"/>	<input checked="" type="checkbox"/>	<input checked="" type="checkbox"/>	<input checked="" type="checkbox"/>	<input checked="" type="checkbox"/>	5
6	<input checked="" type="checkbox"/>	<input checked="" type="checkbox"/>	<input checked="" type="checkbox"/>	<input checked="" type="checkbox"/>	<input checked="" type="checkbox"/>	<input checked="" type="checkbox"/>	<input checked="" type="checkbox"/>	<input checked="" type="checkbox"/>	<input checked="" type="checkbox"/>	<input checked="" type="checkbox"/>	<input checked="" type="checkbox"/>	<input checked="" type="checkbox"/>	<input checked="" type="checkbox"/>	<input checked="" type="checkbox"/>	<input checked="" type="checkbox"/>	<input checked="" type="checkbox"/>	<input checked="" type="checkbox"/>	<input checked="" type="checkbox"/>	<input checked="" type="checkbox"/>	<input checked="" type="checkbox"/>	<input checked="" type="checkbox"/>	<input checked="" type="checkbox"/>	<input checked="" type="checkbox"/>	<input checked="" type="checkbox"/>	6
7	<input checked="" type="checkbox"/>	<input checked="" type="checkbox"/>	<input checked="" type="checkbox"/>	<input checked="" type="checkbox"/>	<input checked="" type="checkbox"/>	<input checked="" type="checkbox"/>	<input checked="" type="checkbox"/>	<input checked="" type="checkbox"/>	<input checked="" type="checkbox"/>	<input checked="" type="checkbox"/>	<input checked="" type="checkbox"/>	<input checked="" type="checkbox"/>	<input checked="" type="checkbox"/>	<input checked="" type="checkbox"/>	<input checked="" type="checkbox"/>	<input checked="" type="checkbox"/>	<input checked="" type="checkbox"/>	<input checked="" type="checkbox"/>	<input checked="" type="checkbox"/>	<input checked="" type="checkbox"/>	<input checked="" type="checkbox"/>	<input checked="" type="checkbox"/>	<input checked="" type="checkbox"/>	<input checked="" type="checkbox"/>	7
8	<input checked="" type="checkbox"/>	<input checked="" type="checkbox"/>	<input checked="" type="checkbox"/>	<input checked="" type="checkbox"/>	<input checked="" type="checkbox"/>	<input checked="" type="checkbox"/>	<input checked="" type="checkbox"/>	<input checked="" type="checkbox"/>	<input checked="" type="checkbox"/>	<input checked="" type="checkbox"/>	<input checked="" type="checkbox"/>	<input checked="" type="checkbox"/>	<input checked="" type="checkbox"/>	<input checked="" type="checkbox"/>	<input checked="" type="checkbox"/>	<input checked="" type="checkbox"/>	<input checked="" type="checkbox"/>	<input checked="" type="checkbox"/>	<input checked="" type="checkbox"/>	<input checked="" type="checkbox"/>	<input checked="" type="checkbox"/>	<input checked="" type="checkbox"/>	<input checked="" type="checkbox"/>	<input checked="" type="checkbox"/>	8
9	<input checked="" type="checkbox"/>	<input checked="" type="checkbox"/>	<input checked="" type="checkbox"/>	<input checked="" type="checkbox"/>	<input checked="" type="checkbox"/>	<input checked="" type="checkbox"/>	<input checked="" type="checkbox"/>	<input checked="" type="checkbox"/>	<input checked="" type="checkbox"/>	<input checked="" type="checkbox"/>	<input checked="" type="checkbox"/>	<input checked="" type="checkbox"/>	<input checked="" type="checkbox"/>	<input checked="" type="checkbox"/>	<input checked="" type="checkbox"/>	<input checked="" type="checkbox"/>	<input checked="" type="checkbox"/>	<input checked="" type="checkbox"/>	<input checked="" type="checkbox"/>	<input checked="" type="checkbox"/>	<input checked="" type="checkbox"/>	<input checked="" type="checkbox"/>	<input checked="" type="checkbox"/>	<input checked="" type="checkbox"/>	9
10	<input checked="" type="checkbox"/>	<input checked="" type="checkbox"/>	<input checked="" type="checkbox"/>	<input checked="" type="checkbox"/>	<input checked="" type="checkbox"/>	<input checked="" type="checkbox"/>	<input checked="" type="checkbox"/>	<input checked="" type="checkbox"/>	<input checked="" type="checkbox"/>	<input checked="" type="checkbox"/>	<input checked="" type="checkbox"/>	<input checked="" type="checkbox"/>	<input checked="" type="checkbox"/>	<input checked="" type="checkbox"/>	<input checked="" type="checkbox"/>	<input checked="" type="checkbox"/>	<input checked="" type="checkbox"/>	<input checked="" type="checkbox"/>	<input checked="" type="checkbox"/>	<input checked="" type="checkbox"/>	<input checked="" type="checkbox"/>	<input checked="" type="checkbox"/>	<input checked="" type="checkbox"/>	<input checked="" type="checkbox"/>	10
11	<input checked="" type="checkbox"/>	<input checked="" type="checkbox"/>	<input checked="" type="checkbox"/>	<input checked="" type="checkbox"/>	<input checked="" type="checkbox"/>	<input checked="" type="checkbox"/>	<input checked="" type="checkbox"/>	<input checked="" type="checkbox"/>	<input checked="" type="checkbox"/>	<input checked="" type="checkbox"/>	<input checked="" type="checkbox"/>	<input checked="" type="checkbox"/>	<input checked="" type="checkbox"/>	<input checked="" type="checkbox"/>	<input checked="" type="checkbox"/>	<input checked="" type="checkbox"/>	<input checked="" type="checkbox"/>	<input checked="" type="checkbox"/>	<input checked="" type="checkbox"/>	<input checked="" type="checkbox"/>	<input checked="" type="checkbox"/>	<input checked="" type="checkbox"/>	<input checked="" type="checkbox"/>	<input checked="" type="checkbox"/>	11
12	<input checked="" type="checkbox"/>	<input checked="" type="checkbox"/>	<input checked="" type="checkbox"/>	<input checked="" type="checkbox"/>	<input checked="" type="checkbox"/>	<input checked="" type="checkbox"/>	<input checked="" type="checkbox"/>	<input checked="" type="checkbox"/>	<input checked="" type="checkbox"/>	<input checked="" type="checkbox"/>	<input checked="" type="checkbox"/>	<input checked="" type="checkbox"/>	<input checked="" type="checkbox"/>	<input checked="" type="checkbox"/>	<input checked="" type="checkbox"/>	<input checked="" type="checkbox"/>	<input checked="" type="checkbox"/>	<input checked="" type="checkbox"/>	<input checked="" type="checkbox"/>	<input checked="" type="checkbox"/>	<input checked="" type="checkbox"/>	<input checked="" type="checkbox"/>	<input checked="" type="checkbox"/>	<input checked="" type="checkbox"/>	12
Outgoing																									
13	<input checked="" type="checkbox"/>	<input checked="" type="checkbox"/>	<input checked="" type="checkbox"/>	<input checked="" type="checkbox"/>	<input checked="" type="checkbox"/>	<input checked="" type="checkbox"/>	<input checked="" type="checkbox"/>	<input checked="" type="checkbox"/>	<input checked="" type="checkbox"/>	<input checked="" type="checkbox"/>	<input checked="" type="checkbox"/>	<input checked="" type="checkbox"/>	<input checked="" type="checkbox"/>	<input checked="" type="checkbox"/>	<input checked="" type="checkbox"/>	<input checked="" type="checkbox"/>	<input checked="" type="checkbox"/>	<input checked="" type="checkbox"/>	<input checked="" type="checkbox"/>	<input checked="" type="checkbox"/>	<input checked="" type="checkbox"/>	<input checked="" type="checkbox"/>	<input checked="" type="checkbox"/>	<input checked="" type="checkbox"/>	13
14	<input checked="" type="checkbox"/>	<input checked="" type="checkbox"/>	<input checked="" type="checkbox"/>	<input checked="" type="checkbox"/>	<input checked="" type="checkbox"/>	<input checked="" type="checkbox"/>	<input checked="" type="checkbox"/>	<input checked="" type="checkbox"/>	<input checked="" type="checkbox"/>	<input checked="" type="checkbox"/>	<input checked="" type="checkbox"/>	<input checked="" type="checkbox"/>	<input checked="" type="checkbox"/>	<input checked="" type="checkbox"/>	<input checked="" type="checkbox"/>	<input checked="" type="checkbox"/>	<input checked="" type="checkbox"/>	<input checked="" type="checkbox"/>	<input checked="" type="checkbox"/>	<input checked="" type="checkbox"/>	<input checked="" type="checkbox"/>	<input checked="" type="checkbox"/>	<input checked="" type="checkbox"/>	<input checked="" type="checkbox"/>	14
15	<input checked="" type="checkbox"/>	<input checked="" type="checkbox"/>	<input checked="" type="checkbox"/>	<input checked="" type="checkbox"/>	<input checked="" type="checkbox"/>	<input checked="" type="checkbox"/>	<input checked="" type="checkbox"/>	<input checked="" type="checkbox"/>	<input checked="" type="checkbox"/>	<input checked="" type="checkbox"/>	<input checked="" type="checkbox"/>	<input checked="" type="checkbox"/>	<input checked="" type="checkbox"/>	<input checked="" type="checkbox"/>	<input checked="" type="checkbox"/>	<input checked="" type="checkbox"/>	<input checked="" type="checkbox"/>	<input checked="" type="checkbox"/>	<input checked="" type="checkbox"/>	<input checked="" type="checkbox"/>	<input checked="" type="checkbox"/>	<input checked="" type="checkbox"/>	<input checked="" type="checkbox"/>	<input checked="" type="checkbox"/>	15
16	<input checked="" type="checkbox"/>	<input checked="" type="checkbox"/>	<input checked="" type="checkbox"/>	<input checked="" type="checkbox"/>	<input checked="" type="checkbox"/>	<input checked="" type="checkbox"/>	<input checked="" type="checkbox"/>	<input checked="" type="checkbox"/>	<input checked="" type="checkbox"/>	<input checked="" type="checkbox"/>	<input checked="" type="checkbox"/>	<input checked="" type="checkbox"/>	<input checked="" type="checkbox"/>	<input checked="" type="checkbox"/>	<input checked="" type="checkbox"/>	<input checked="" type="checkbox"/>	<input checked="" type="checkbox"/>	<input checked="" type="checkbox"/>	<input checked="" type="checkbox"/>	<input checked="" type="checkbox"/>	<input checked="" type="checkbox"/>	<input checked="" type="checkbox"/>	<input checked="" type="checkbox"/>	<input checked="" type="checkbox"/>	16
17	<input checked="" type="checkbox"/>	<input checked="" type="checkbox"/>	<input checked="" type="checkbox"/>	<input checked="" type="checkbox"/>	<input checked="" type="checkbox"/>	<input checked="" type="checkbox"/>	<input checked="" type="checkbox"/>	<input checked="" type="checkbox"/>	<input checked="" type="checkbox"/>	<input checked="" type="checkbox"/>	<input checked="" type="checkbox"/>	<input checked="" type="checkbox"/>	<input checked="" type="checkbox"/>	<input checked="" type="checkbox"/>	<input checked="" type="checkbox"/>	<input checked="" type="checkbox"/>	<input checked="" type="checkbox"/>	<input checked="" type="checkbox"/>	<input checked="" type="checkbox"/>	<input checked="" type="checkbox"/>	<input checked="" type="checkbox"/>	<input checked="" type="checkbox"/>	<input checked="" type="checkbox"/>	<input checked="" type="checkbox"/>	17
18	<input checked="" type="checkbox"/>	<input checked="" type="checkbox"/>	<input checked="" type="checkbox"/>	<input checked="" type="checkbox"/>	<input checked="" type="checkbox"/>	<input checked="" type="checkbox"/>	<input checked="" type="checkbox"/>	<input checked="" type="checkbox"/>	<input checked="" type="checkbox"/>	<input checked="" type="checkbox"/>	<input checked="" type="checkbox"/>	<input checked="" type="checkbox"/>	<input checked="" type="checkbox"/>	<input checked="" type="checkbox"/>	<input checked="" type="checkbox"/>	<input checked="" type="checkbox"/>	<input checked="" type="checkbox"/>	<input checked="" type="checkbox"/>	<input checked="" type="checkbox"/>	<input checked="" type="checkbox"/>	<input checked="" type="checkbox"/>	<input checked="" type="checkbox"/>	<input checked="" type="checkbox"/>	<input checked="" type="checkbox"/>	18
19	<input checked="" type="checkbox"/>	<input checked="" type="checkbox"/>	<input checked="" type="checkbox"/>	<input checked="" type="checkbox"/>	<input checked="" type="checkbox"/>	<input checked="" type="checkbox"/>	<input checked="" type="checkbox"/>	<input checked="" type="checkbox"/>	<input checked="" type="checkbox"/>	<input checked="" type="checkbox"/>	<input checked="" type="checkbox"/>	<input checked="" type="checkbox"/>	<input checked="" type="checkbox"/>	<input checked="" type="checkbox"/>	<input checked="" type="checkbox"/>	<input checked="" type="checkbox"/>	<input checked="" type="checkbox"/>	<input checked="" type="checkbox"/>	<input checked="" type="checkbox"/>	<input checked="" type="checkbox"/>	<input checked="" type="checkbox"/>	<input checked="" type="checkbox"/>	<input checked="" type="checkbox"/>	<input checked="" type="checkbox"/>	19
20	<input checked="" type="checkbox"/>	<input checked="" type="checkbox"/>	<input checked="" type="checkbox"/>	<input checked="" type="checkbox"/>	<input checked="" type="checkbox"/>	<input checked="" type="checkbox"/>	<input checked="" type="checkbox"/>	<input checked="" type="checkbox"/>	<input checked="" type="checkbox"/>	<input checked="" type="checkbox"/>	<input checked="" type="checkbox"/>	<input checked="" type="checkbox"/>	<input checked="" type="checkbox"/>	<input checked="" type="checkbox"/>	<input checked="" type="checkbox"/>	<input checked="" type="checkbox"/>	<input checked="" type="checkbox"/>	<input checked="" type="checkbox"/>	<input checked="" type="checkbox"/>	<input checked="" type="checkbox"/>	<input checked="" type="checkbox"/>	<input checked="" type="checkbox"/>	<input checked="" type="checkbox"/>	<input checked="" type="checkbox"/>	20
21	<input checked="" type="checkbox"/>	<input checked="" type="checkbox"/>	<input checked="" type="checkbox"/>	<input checked="" type="checkbox"/>	<input checked="" type="checkbox"/>	<input checked="" type="checkbox"/>	<input checked="" type="checkbox"/>	<input checked="" type="checkbox"/>	<input checked="" type="checkbox"/>	<input checked="" type="checkbox"/>	<input checked="" type="checkbox"/>	<input checked="" type="checkbox"/>	<input checked="" type="checkbox"/>	<input checked="" type="checkbox"/>	<input checked="" type="checkbox"/>	<input checked="" type="checkbox"/>	<input checked="" type="checkbox"/>	<input checked="" type="checkbox"/>	<input checked="" type="checkbox"/>	<input checked="" type="checkbox"/>	<input checked="" type="checkbox"/>	<input checked="" type="checkbox"/>	<input checked="" type="checkbox"/>	<input checked="" type="checkbox"/>	21
22	<input checked="" type="checkbox"/>	<input checked="" type="checkbox"/>	<input checked="" type="checkbox"/>	<input checked="" type="checkbox"/>	<input checked="" type="checkbox"/>	<input checked="" type="checkbox"/>	<input checked="" type="checkbox"/>	<input checked="" type="checkbox"/>	<input checked="" type="checkbox"/>	<input checked="" type="checkbox"/>	<input checked="" type="checkbox"/>	<input checked="" type="checkbox"/>	<input checked="" type="checkbox"/>	<input checked="" type="checkbox"/>	<input checked="" type="checkbox"/>	<input checked="" type="checkbox"/>	<input checked="" type="checkbox"/>	<input checked="" type="checkbox"/>	<input checked="" type="checkbox"/>	<input checked="" type="checkbox"/>	<input checked="" type="checkbox"/>	<input checked="" type="checkbox"/>	<input checked="" type="checkbox"/>	<input checked="" type="checkbox"/>	22
23	<input checked="" type="checkbox"/>	<input checked="" type="checkbox"/>	<input checked="" type="checkbox"/>	<input checked="" type="checkbox"/>	<input checked="" type="checkbox"/>	<input checked="" type="checkbox"/>	<input checked="" type="checkbox"/>	<input checked="" type="checkbox"/>	<input checked="" type="checkbox"/>	<input checked="" type="checkbox"/>	<input checked="" type="checkbox"/>	<input checked="" type="checkbox"/>	<input checked="" type="checkbox"/>	<input checked="" type="checkbox"/>	<input checked="" type="checkbox"/>	<input checked="" type="checkbox"/>	<input checked="" type="checkbox"/>	<input checked="" type="checkbox"/>	<input checked="" type="checkbox"/>	<input checked="" type="checkbox"/>	<input checked="" type="checkbox"/>	<input checked="" type="checkbox"/>	<input checked="" type="checkbox"/>	<input checked="" type="checkbox"/>	23
24	<input checked="" type="checkbox"/>	<input checked="" type="checkbox"/>	<input checked="" type="checkbox"/>	<input checked="" type="checkbox"/>	<input checked="" type="checkbox"/>	<input checked="" type="checkbox"/>	<input checked="" type="checkbox"/>	<input checked="" type="checkbox"/>	<input checked="" type="checkbox"/>	<input checked="" type="checkbox"/>	<input checked="" type="checkbox"/>	<input checked="" type="checkbox"/>	<input checked="" type="checkbox"/>	<input checked="" type="checkbox"/>	<input checked="" type="checkbox"/>	<input checked="" type="checkbox"/>	<input checked="" type="checkbox"/>	<input checked="" type="checkbox"/>	<input checked="" type="checkbox"/>	<input checked="" type="checkbox"/>	<input checked="" type="checkbox"/>	<input checked="" type="checkbox"/>	<input checked="" type="checkbox"/>	<input checked="" type="checkbox"/>	24
CPU	<input checked="" type="checkbox"/>	<input checked="" type="checkbox"/>	<input checked="" type="checkbox"/>	<input checked="" type="checkbox"/>	<input checked="" type="checkbox"/>	<input checked="" type="checkbox"/>	<input checked="" type="checkbox"/>	<input checked="" type="checkbox"/>	<input checked="" type="checkbox"/>	<input checked="" type="checkbox"/>	<input checked="" type="checkbox"/>	<input checked="" type="checkbox"/>	<input checked="" type="checkbox"/>	<input checked="" type="checkbox"/>	<input checked="" type="checkbox"/>	<input checked="" type="checkbox"/>	<input checked="" type="checkbox"/>	<input checked="" type="checkbox"/>	<input checked="" type="checkbox"/>	<input checked="" type="checkbox"/>	<input checked="" type="checkbox"/>	<input checked="" type="checkbox"/>	<input checked="" type="checkbox"/>	<input checked="" type="checkbox"/>	CPU

Apply Cancel

The following screen shows users on a port-based, port-isolated VLAN configuration.

**Figure 36** Advanced Application > VLAN: Port Based VLAN Setup (Port Isolation)

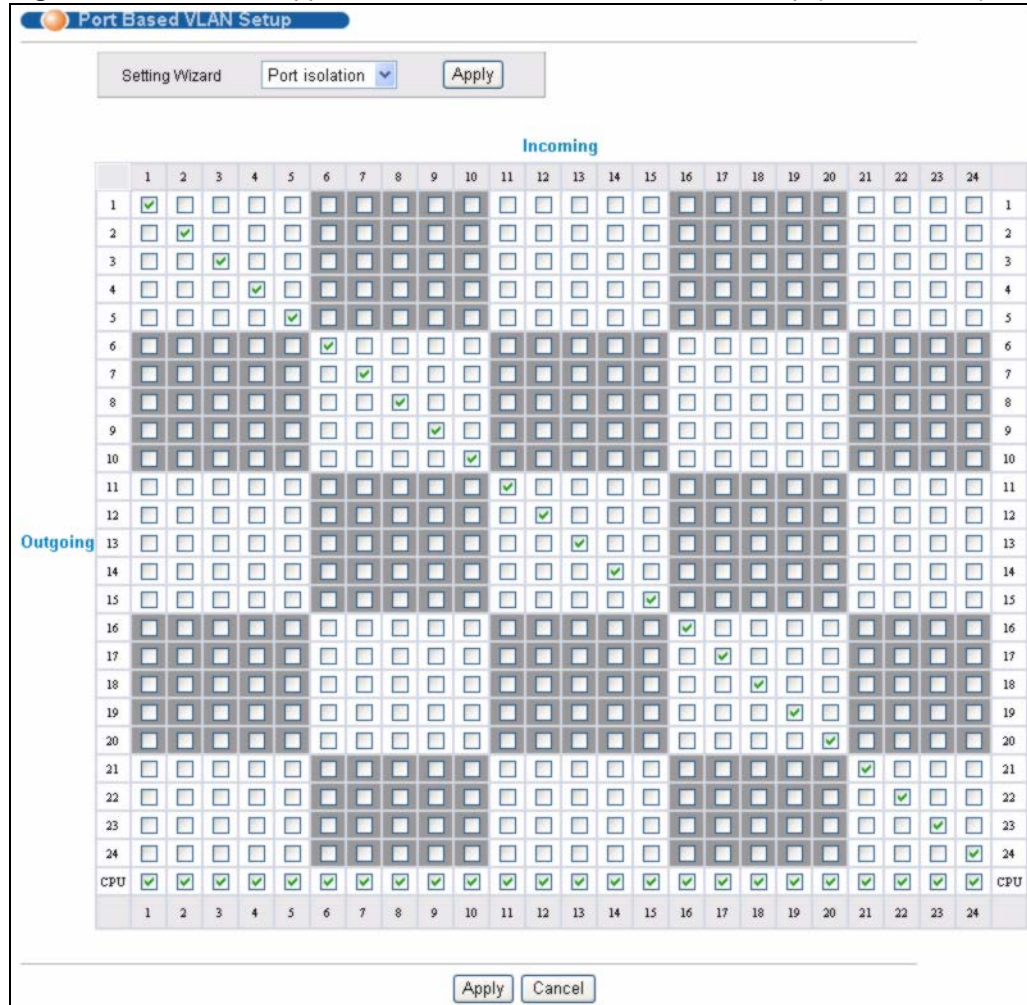

The following table describes the labels in this screen.

**Table 18** Advanced Application > VLAN: Port Based VLAN Setup

LABEL	DESCRIPTION
Setting Wizard	<p>Choose <b>All connected</b> or <b>Port isolation</b>.</p> <p><b>All connected</b> means all ports can communicate with each other, that is, there are no virtual LANs. All incoming and outgoing ports are selected. This option is the most flexible but also the least secure.</p> <p><b>Port isolation</b> means that each port can only communicate with the CPU management port and cannot communicate with each other. All incoming ports are selected while only the CPU outgoing port is selected. This option is the most limiting but also the most secure.</p> <p>After you make your selection, click <b>Apply</b> (top right of screen) to display the screens as mentioned above. You can still customize these settings by adding/deleting incoming or outgoing ports, but you must also click <b>Apply</b> at the bottom of the screen.</p>
Incoming	<p>These are the ingress ports; an ingress port is an incoming port, that is, a port through which a data packet enters. If you wish to allow two subscriber ports to talk to each other, you must define the ingress port for both ports. The numbers in the top row denote the incoming port for the corresponding port listed on the left (its outgoing port). <b>CPU</b> refers to the Switch management port. By default it forms a VLAN with all Ethernet ports. If it does not form a VLAN with a particular port then the Switch cannot be managed from that port.</p>

**Table 18** Advanced Application > VLAN: Port Based VLAN Setup (continued)

LABEL	DESCRIPTION
Outgoing	These are the egress ports. An egress port is an outgoing port, that is, a port through which a data packet leaves. If you wish to allow two subscriber ports to talk to each other, you must define the egress port for both ports. <b>CPU</b> refers to the Switch management port. By default it forms a VLAN with all Ethernet ports. If it does not form a VLAN with a particular port then the Switch cannot be managed from that port.
Apply	Click <b>Apply</b> to save your changes to the Switch's run-time memory. The Switch loses these changes if it is turned off or loses power, so use the <b>Save</b> link on the top navigation panel to save your changes to the non-volatile memory when you are done configuring.
Cancel	Click <b>Cancel</b> to begin configuring this screen afresh.





# Static MAC Forward Setup

Use these screens to configure static MAC address forwarding.

## 9.1 Overview

This chapter discusses how to configure forwarding rules based on MAC addresses of devices on your network.

## 9.2 Configuring Static MAC Forwarding

A static MAC address is an address that has been manually entered in the MAC address table. Static MAC addresses do not age out. When you set up static MAC address rules, you are setting static MAC addresses for a port. This may reduce the need for broadcasting.

Static MAC address forwarding together with port security allows only computers in the MAC address table on a port to access the Switch. See [Chapter 16 on page 121](#) for more information on port security.

Click **Advanced Applications > Static MAC Forwarding** in the navigation panel to display the configuration screen as shown.

**Figure 37** Advanced Application > Static MAC Forwarding

Index	Active	Name	MAC Address	VID	Port	Delete

The following table describes the labels in this screen.

**Table 19** Advanced Application > Static MAC Forwarding

LABEL	DESCRIPTION
Active	Select this check box to activate your rule. You may temporarily deactivate a rule without deleting it by clearing this check box.
Name	Enter a descriptive name for identification purposes for this static MAC address forwarding rule.
MAC Address	Enter the MAC address in valid MAC address format, that is, six hexadecimal character pairs.  Note: Static MAC addresses do not age out.
VID	Enter the VLAN identification number.
Port	Enter the port where the MAC address entered in the previous field will be automatically forwarded.
Add	Click <b>Add</b> to save your rule to the Switch's run-time memory. The Switch loses this rule if it is turned off or loses power, so use the <b>Save</b> link on the top navigation panel to save your changes to the non-volatile memory when you are done configuring.
Cancel	Click <b>Cancel</b> to begin configuring this screen afresh.
Clear	Click <b>Clear</b> to reset the fields to the factory defaults.
Index	Click an index number to modify a static MAC address rule for a port.
Active	This field displays whether this static MAC address forwarding rule is active ( <b>Yes</b> ) or not ( <b>No</b> ). You may temporarily deactivate a rule without deleting it.
Name	This field displays the descriptive name for identification purposes for this static MAC address-forwarding rule.
MAC Address	This field displays the MAC address that will be forwarded and the VLAN identification number to which the MAC address belongs.
VID	This field displays the ID number of the VLAN group.
Port	This field displays the port where the MAC address shown in the next field will be forwarded.
Delete	Click <b>Delete</b> to remove the selected entry from the summary table.
Cancel	Click <b>Cancel</b> to clear the <b>Delete</b> check boxes.

# Spanning Tree Protocol

The Switch supports Spanning Tree Protocol (STP), Rapid Spanning Tree Protocol (RSTP) and Multiple Spanning Tree Protocol (MSTP) as defined in the following standards.

- IEEE 802.1D Spanning Tree Protocol
- IEEE 802.1w Rapid Spanning Tree Protocol
- IEEE 802.1s Multiple Spanning Tree Protocol

The Switch also allows you to set up multiple STP configurations (or trees). Ports can then be assigned to the trees.

## 10.1 STP/RSTP Overview

(R)STP detects and breaks network loops and provides backup links between switches, bridges or routers. It allows a Switch to interact with other (R)STP-compliant switches in your network to ensure that only one path exists between any two stations on the network.

The Switch uses IEEE 802.1w RSTP (Rapid Spanning Tree Protocol) that allows faster convergence of the spanning tree than STP (while also being backwards compatible with STP-only aware bridges). In RSTP, topology change information is directly propagated throughout the network from the device that generates the topology change. In STP, a longer delay is required as the device that causes a topology change first notifies the root bridge and then the root bridge notifies the network. Both RSTP and STP flush unwanted learned addresses from the filtering database. In RSTP, the port states are Discarding, Learning, and Forwarding.



---

In this user's guide, "STP" refers to both STP and RSTP.

---

### 10.1.1 STP Terminology

The root bridge is the base of the spanning tree.

Path cost is the cost of transmitting a frame onto a LAN through that port. The recommended cost is assigned according to the speed of the link to which a port is attached. The slower the media, the higher the cost.

**Table 20** STP Path Costs

	LINK SPEED	RECOMMENDED VALUE	RECOMMENDED RANGE	ALLOWED RANGE
Path Cost	4Mbps	250	100 to 1000	1 to 65535
Path Cost	10Mbps	100	50 to 600	1 to 65535
Path Cost	16Mbps	62	40 to 400	1 to 65535
Path Cost	100Mbps	19	10 to 60	1 to 65535
Path Cost	1Gbps	4	3 to 10	1 to 65535
Path Cost	10Gbps	2	1 to 5	1 to 65535

On each bridge, the bridge communicates with the root through the root port. The root port is the port on this Switch with the lowest path cost to the root (the root path cost). If there is no root port, then this Switch has been accepted as the root bridge of the spanning tree network.

For each LAN segment, a designated bridge is selected. This bridge has the lowest cost to the root among the bridges connected to the LAN.

## 10.1.2 How STP Works

After a bridge determines the lowest cost-spanning tree with STP, it enables the root port and the ports that are the designated ports for connected LANs, and disables all other ports that participate in STP. Network packets are therefore only forwarded between enabled ports, eliminating any possible network loops.

STP-aware switches exchange Bridge Protocol Data Units (BPDUs) periodically. When the bridged LAN topology changes, a new spanning tree is constructed.

Once a stable network topology has been established, all bridges listen for Hello BPDUs (Bridge Protocol Data Units) transmitted from the root bridge. If a bridge does not get a Hello BPDUs after a predefined interval (Max Age), the bridge assumes that the link to the root bridge is down. This bridge then initiates negotiations with other bridges to reconfigure the network to re-establish a valid network topology.

## 10.1.3 STP Port States

STP assigns five port states to eliminate packet looping. A bridge port is not allowed to go directly from blocking state to forwarding state so as to eliminate transient loops.

**Table 21** STP Port States

PORT STATE	DESCRIPTION
Disabled	STP is disabled (default).
Blocking	Only configuration and management BPDUs are received and processed.

**Table 21** STP Port States

PORT STATE	DESCRIPTION
Listening	All BPDUs are received and processed.  Note: The listening state does not exist in RSTP.
Learning	All BPDUs are received and processed. Information frames are submitted to the learning process but not forwarded.
Forwarding	All BPDUs are received and processed. All information frames are received and forwarded.

## 10.1.4 Multiple STP

Multiple Spanning Tree Protocol (IEEE 802.1s) is backwards compatible with STP/RSTP and addresses the limitations of existing spanning tree protocols (STP and RSTP) in networks to include the following features:

- One Common and Internal Spanning Tree (CIST) that represents the entire network's connectivity.
- Grouping of multiple bridges (or switching devices) into regions that appear as one single bridge on the network.
- A VLAN can be mapped to a specific Multiple Spanning Tree Instance (MSTI). MSTI allows multiple VLANs to use the same spanning tree.
- Load-balancing is possible as traffic from different VLANs can use distinct paths in a region.

### 10.1.4.1 MSTP Network Example

The following figure shows a network example where two VLANs are configured on the two switches. If the switches are using STP or RSTP, the link for VLAN 2 will be blocked as STP and RSTP allow only one link in the network and block the redundant link.

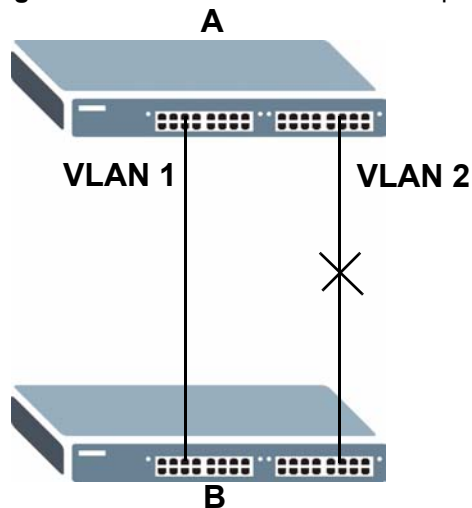
**Figure 38** STP/RSTP Network Example

With MSTP, VLANs 1 and 2 are mapped to different spanning trees in the network. Thus traffic from the two VLANs travel on different paths. The following figure shows the network example using MSTP.

**Figure 39** MSTP Network Example

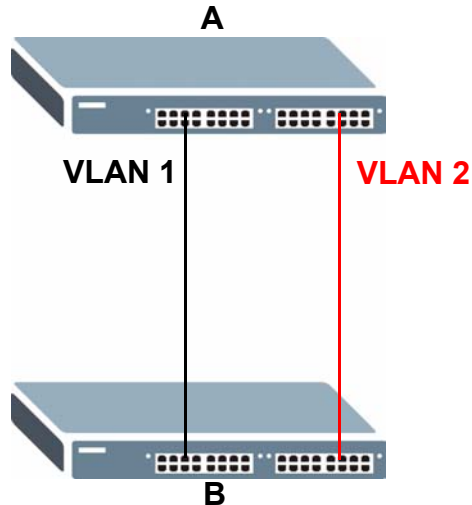

#### 10.1.4.2 MST Region

An MST region is a logical grouping of multiple network devices that appears as a single device to the rest of the network. Each MSTP-enabled device can only belong to one MST region. When BPDUs enter an MST region, external path cost (of paths outside this region) is increased by one. Internal path cost (of paths within this region) is increased by one when BPDUs traverse the region.

Devices that belong to the same MST region are configured to have the same MSTP configuration identification settings. These include the following parameters:

- Name of the MST region
- Revision level as the unique number for the MST region
- VLAN-to-MST Instance mapping

#### 10.1.4.3 MST Instance

An MST Instance (MSTI) is a spanning tree instance. VLANs can be configured to run on a specific MSTI. Each created MSTI is identified by a unique number (known as an MST ID) known internally to a region. Thus an MSTI does not span across MST regions.

The following figure shows an example where there are two MST regions. Regions 1 and 2 have 2 spanning tree instances.

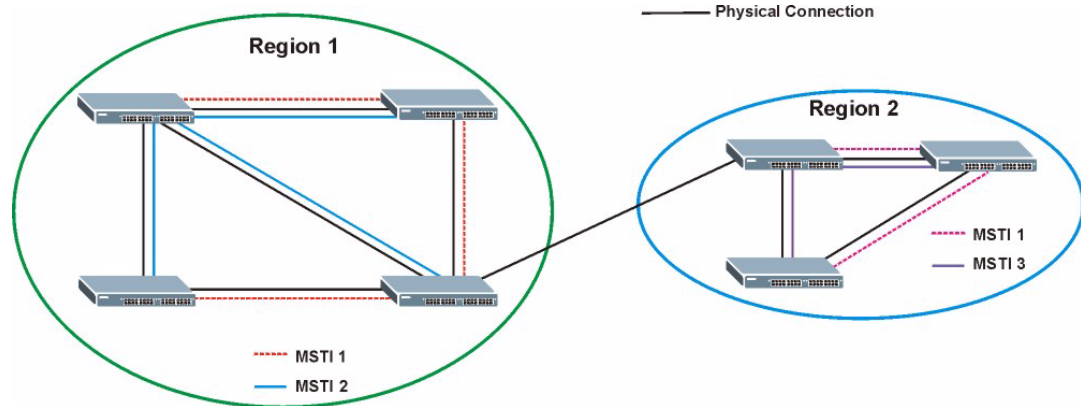
**Figure 40** MSTIs in Different Regions

#### 10.1.4.4 Common and Internal Spanning Tree (CIST)

A CIST represents the connectivity of the entire network and it is equivalent to a spanning tree in an STP/RSTP. The CIST is the default MST instance (MSTID 0). Any VLANs that are not members of an MST instance are members of the CIST. In an MSTP-enabled network, there is only one CIST that runs between MST regions and single spanning tree devices. A network may contain multiple MST regions and other network segments running RSTP.

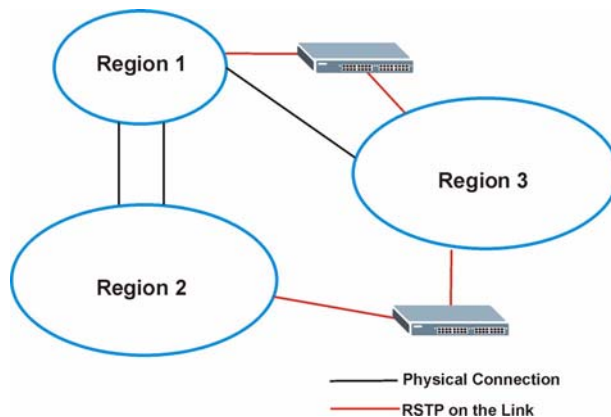
**Figure 41** MSTP and Legacy RSTP Network Example

## 10.2 Spanning Tree Protocol Status Screen

The Spanning Tree Protocol status screen changes depending on what standard you choose to implement on your network. Click **Advanced Application > Spanning Tree Protocol** to see the screen as shown.

**Figure 42** Advanced Application > Spanning Tree Protocol

Bridge	Root	Our Bridge
Bridge ID	0000-000000000000	0000-000000000000
Hello Time (second)	0	0
Max Age (second)	0	0
Forwarding Delay (second)	0	0
Cost to Bridge	0	
Port ID	0x0000	
Topology Changed Times		0
Time Since Last Change		0:00:00

This screen differs depending on which STP mode (RSTP or MSTP) you configure on the Switch. This screen is described in detail in the section that follows the configuration section for each STP mode. Click **Configuration** to activate one of the STP standards on the Switch.

## 10.3 Spanning Tree Configuration

Use the **Spanning Tree Configuration** screen to activate one of the STP modes on the Switch. Click **Configuration** in the **Advanced Application > Spanning Tree Protocol**.

**Figure 43** Advanced Application > Spanning Tree Protocol > Configuration

The following table describes the labels in this screen.

**Table 22** Advanced Application > Spanning Tree Protocol > Configuration

LABEL	DESCRIPTION
Spanning Tree Mode	You can activate one of the STP modes on the Switch. Select <b>Rapid Spanning Tree</b> or <b>Multiple Spanning Tree</b> . See <a href="#">Section 10.1 on page 91</a> for background information on STP.
Apply	Click <b>Apply</b> to save your changes to the Switch's run-time memory. The Switch loses these changes if it is turned off or loses power, so use the <b>Save</b> link on the top navigation panel to save your changes to the non-volatile memory when you are done configuring.
Cancel	Click <b>Cancel</b> to begin configuring this screen afresh.

## 10.4 Configure Rapid Spanning Tree Protocol

Use this screen to configure RSTP settings, see [Section 10.1 on page 91](#) for more information on RSTP. Click **RSTP** in the **Advanced Application > Spanning Tree Protocol** screen.



**Figure 44** Advanced Application > Spanning Tree Protocol > RSTP

Port	Active	Priority	Path Cost
*	<input type="checkbox"/>		
1	<input type="checkbox"/>	128	4
2	<input type="checkbox"/>	128	4
3	<input type="checkbox"/>	128	4
4	<input type="checkbox"/>	128	4
5	<input type="checkbox"/>	128	4
6	<input type="checkbox"/>	128	4
7	<input type="checkbox"/>	128	4

The following table describes the labels in this screen.

**Table 23** Advanced Application > Spanning Tree Protocol > RSTP

LABEL	DESCRIPTION
Status	Click <b>Status</b> to display the <b>RSTP Status</b> screen (see <a href="#">Figure 45 on page 99</a> ).
Active	Select this check box to activate RSTP. Clear this checkbox to disable RSTP.  <b>Note:</b> You must also activate <b>Rapid Spanning Tree</b> in the <b>Advanced Application &gt; Spanning Tree Protocol &gt; Configuration</b> screen to enable RSTP on the Switch.
Bridge Priority	Bridge priority is used in determining the root switch, root port and designated port. The switch with the highest priority (lowest numeric value) becomes the STP root switch. If all switches have the same priority, the switch with the lowest MAC address will then become the root switch. Select a value from the drop-down list box.  The lower the numeric value you assign, the higher the priority for this bridge. Bridge Priority determines the root bridge, which in turn determines Hello Time, Max Age and Forwarding Delay.
Hello Time	This is the time interval in seconds between BPDU (Bridge Protocol Data Units) configuration message generations by the root switch. The allowed range is 1 to 10 seconds.

**Table 23** Advanced Application > Spanning Tree Protocol > RSTP (continued)

LABEL	DESCRIPTION
MAX Age	This is the maximum time (in seconds) a switch can wait without receiving a BPDU before attempting to reconfigure. All switch ports (except for designated ports) should receive BPDUs at regular intervals. Any port that ages out STP information (provided in the last BPDU) becomes the designated port for the attached LAN. If it is a root port, a new root port is selected from among the switch ports attached to the network. The allowed range is 6 to 40 seconds.
Forwarding Delay	This is the maximum time (in seconds) a switch will wait before changing states. This delay is required because every switch must receive information about topology changes before it starts to forward frames. In addition, each port needs time to listen for conflicting information that would make it return to a blocking state; otherwise, temporary data loops might result. The allowed range is 4 to 30 seconds. As a general rule:  Note: $2 * (\text{Forward Delay} - 1) \geq \text{Max Age} \geq 2 * (\text{Hello Time} + 1)$
Port	This field displays the port number.
*	Settings in this row apply to all ports. Use this row only if you want to make some settings the same for all ports. Use this row first to set the common settings and then make adjustments on a port-by-port basis.  Note: Changes in this row are copied to all the ports as soon as you make them.
Active	Select this check box to activate RSTP on this port.
Priority	Configure the priority for each port here. Priority decides which port should be disabled when more than one port forms a loop in a switch. Ports with a higher priority numeric value are disabled first. The allowed range is between 0 and 255 and the default value is 128.
Path Cost	Path cost is the cost of transmitting a frame on to a LAN through that port. It is recommended to assign this value according to the speed of the bridge. The slower the media, the higher the cost - see <a href="#">Table 20 on page 92</a> for more information.
Apply	Click <b>Apply</b> to save your changes to the Switch's run-time memory. The Switch loses these changes if it is turned off or loses power, so use the <b>Save</b> link on the top navigation panel to save your changes to the non-volatile memory when you are done configuring.
Cancel	Click <b>Cancel</b> to begin configuring this screen afresh.

## 10.5 Rapid Spanning Tree Protocol Status

Click **Advanced Application > Spanning Tree Protocol** in the navigation panel to display the status screen as shown next. See [Section 10.1 on page 91](#) for more information on RSTP.



This screen is only available after you activate RSTP on the Switch.

**Figure 45** Advanced Application > Spanning Tree Protocol > Status: RSTP

The screenshot shows the 'Spanning Tree Protocol Status' screen with the following data:

Bridge	Root	Our Bridge
Bridge ID	8000-00a0c5012346	8000-00a0c5012346
Hello Time (second)	2	2
Max Age (second)	20	20
Forwarding Delay (second)	15	15
Cost to Bridge	0	
Port ID	0X0000	
Topology Changed Times		0
Time Since Last Change		0:00:08

The following table describes the labels in this screen.

**Table 24** Advanced Application > Spanning Tree Protocol > Status: RSTP

LABEL	DESCRIPTION
Configuration	Click <b>Configuration</b> to specify which STP mode you want to activate. Click <b>RSTP</b> to edit RSTP settings on the Switch.
Bridge	<b>Root</b> refers to the base of the spanning tree (the root bridge). <b>Our Bridge</b> is this Switch. This Switch may also be the root bridge.
Bridge ID	This is the unique identifier for this bridge, consisting of the bridge priority plus the MAC address. This ID is the same for <b>Root</b> and <b>Our Bridge</b> if the Switch is the root switch.
Hello Time (second)	This is the time interval (in seconds) at which the root switch transmits a configuration message. The root bridge determines Hello Time, Max Age and Forwarding Delay.
Max Age (second)	This is the maximum time (in seconds) a switch can wait without receiving a configuration message before attempting to reconfigure.
Forwarding Delay (second)	This is the time (in seconds) the root switch will wait before changing states (that is, listening to learning to forwarding). See <a href="#">Section 10.1.3 on page 92</a> for information on port states.  <b>Note:</b> The listening state does not exist in RSTP.
Cost to Bridge	This is the path cost from the root port on this Switch to the root switch.
Port ID	This is the priority and number of the port on the Switch through which this Switch must communicate with the root of the Spanning Tree.
Topology Changed Times	This is the number of times the spanning tree has been reconfigured.
Time Since Last Change	This is the time since the spanning tree was last reconfigured.

## 10.6 Configure Multiple Spanning Tree Protocol

To configure MSTP, click **MSTP** in the **Advanced Application > Spanning Tree Protocol** screen. See [Section 10.1.4 on page 93](#) for more information on MSTP.

**Figure 46** Advanced Application > Spanning Tree Protocol > MSTP

Multiple Spanning Tree Protocol
Status

---

**Bridge:**

Active	<input type="checkbox"/>
Hello Time	2 seconds
MAX Age	20 seconds
Forwarding Delay	15 seconds
Maximum hops	128
Configuration Name	00a0c5012346
Revision Number	0

---

**Instance:**

Instance	<input type="text"/>		
Bridge Priority	32768		
VLAN Range	Start <input type="text"/>	End <input type="text"/>	<input type="button" value="Add"/> <input type="button" value="Remove"/> <input type="button" value="Clear"/>
Enabled VLAN(s)			

Port	Active	Priority	Path Cost
*	<input type="checkbox"/>	<input type="text"/>	<input type="text"/>
1	<input type="checkbox"/>	128	4
2	<input type="checkbox"/>	128	4
3	<input type="checkbox"/>	128	4
4	<input type="checkbox"/>	128	4
5	<input type="checkbox"/>	128	4
6	<input type="checkbox"/>	128	4
7	<input type="checkbox"/>	128	4

---

Instance	VLAN	Active Port	Delete
0	1-4094	-	

The following table describes the labels in this screen.

**Table 25** Advanced Application > Spanning Tree Protocol > MSTP

LABEL	DESCRIPTION
Status	Click <b>Status</b> to display the <b>MSTP Status</b> screen (see <a href="#">Figure 47 on page 103</a> ).
Active	<p>Select this check box to activate MSTP on the Switch. Clear this to disable MSTP on the Switch.</p> <p><b>Note:</b> You must also activate <b>Multiple Spanning Tree</b> in the <b>Advanced Application &gt; Spanning Tree Protocol &gt; Configuration</b> screen to enable MSTP on the Switch.</p>
Hello Time	This is the time interval in seconds between BPDU (Bridge Protocol Data Units) configuration message generations by the root switch. The allowed range is 1 to 10 seconds.
MAX Age	This is the maximum time (in seconds) a switch can wait without receiving a BPDU before attempting to reconfigure. All switch ports (except for designated ports) should receive BPDUs at regular intervals. Any port that ages out STP information (provided in the last BPDU) becomes the designated port for the attached LAN. If it is a root port, a new root port is selected from among the Switch ports attached to the network. The allowed range is 6 to 40 seconds.
Forwarding Delay	<p>This is the maximum time (in seconds) a switch will wait before changing states. This delay is required because every switch must receive information about topology changes before it starts to forward frames. In addition, each port needs time to listen for conflicting information that would make it return to a blocking state; otherwise, temporary data loops might result. The allowed range is 4 to 30 seconds. As a general rule:</p> <p><b>Note:</b> <math>2 * (\text{Forward Delay} - 1) \geq \text{Max Age} \geq 2 * (\text{Hello Time} + 1)</math></p>
Maximum hops	Enter the number of hops (between 1 and 255) in an MSTP region before the BPDU is discarded and the port information is aged.
Configuration Name	Enter a descriptive name (up to 32 characters) of an MST region.
Revision Number	Enter a number to identify a region's configuration. Devices must have the same revision number to belong to the same region.
Apply	Click <b>Apply</b> to save your changes to the Switch's run-time memory. The Switch loses these changes if it is turned off or loses power, so use the <b>Save</b> link on the top navigation panel to save your changes to the non-volatile memory when you are done configuring.
Cancel	Click <b>Cancel</b> to begin configuring this screen afresh.
Instance	Use this section to configure MSTI (Multiple Spanning Tree Instance) settings.
Instance	Enter the number you want to use to identify this MST instance on the Switch. The Switch supports instance numbers 0-16.
Bridge Priority	<p>Set the priority of the Switch for the specific spanning tree instance. The lower the number, the more likely the Switch will be chosen as the root bridge within the spanning tree instance.</p> <p>Enter priority values between 0 and 61440 in increments of 4096 (thus valid values are 4096, 8192, 12288, 16384, 20480, 24576, 28672, 32768, 36864, 40960, 45056, 49152, 53248, 57344 and 61440).</p>

**Table 25** Advanced Application > Spanning Tree Protocol > MSTP (continued)

LABEL	DESCRIPTION
VLAN Range	Enter the start of the VLAN ID range that you want to add or remove from the VLAN range edit area in the <b>Start</b> field. Enter the end of the VLAN ID range that you want to add or remove from the VLAN range edit area in the <b>End</b> field. Next click: <ul style="list-style-type: none"> <li>• <b>Add</b> - to add this range of VLAN(s) to be mapped to the MST instance.</li> <li>• <b>Remove</b> - to remove this range of VLAN(s) from being mapped to the MST instance.</li> <li>• <b>Clear</b> - to remove all VLAN(s) from being mapped to this MST instance.</li> </ul>
Enabled VLAN(s)	This field displays which VLAN(s) are mapped to this MST instance.
Port	This field displays the port number.
*	Settings in this row apply to all ports. Use this row only if you want to make some settings the same for all ports. Use this row first to set the common settings and then make adjustments on a port-by-port basis.  Note: Changes in this row are copied to all the ports as soon as you make them.
Active	Select this check box to add this port to the MST instance.
Priority	Configure the priority for each port here. Priority decides which port should be disabled when more than one port forms a loop in the Switch. Ports with a higher priority numeric value are disabled first. The allowed range is between 0 and 255 and the default value is 128.
Path Cost	Path cost is the cost of transmitting a frame on to a LAN through that port. It is recommended to assign this value according to the speed of the bridge. The slower the media, the higher the cost - see <a href="#">Table 20 on page 92</a> for more information.
Add	Click <b>Add</b> to save this MST instance to the Switch's run-time memory. The Switch loses this change if it is turned off or loses power, so use the <b>Save</b> link on the top navigation panel to save your changes to the non-volatile memory when you are done configuring.
Cancel	Click <b>Cancel</b> to begin configuring this screen afresh.
Instance	This field displays the ID of an MST instance.
VLAN	This field displays the VID (or VID ranges) to which the MST instance is mapped.
Active Port	This field display the ports configured to participate in the MST instance.
Delete	Check the rule(s) that you want to remove in the <b>Delete</b> column and then click the <b>Delete</b> button.
Cancel	Click <b>Cancel</b> to begin configuring this screen afresh.

## 10.7 Multiple Spanning Tree Protocol Status

Click **Advanced Application > Spanning Tree Protocol** in the navigation panel to display the status screen as shown next. See [Section 10.1.4 on page 93](#) for more information on MSTP.



This screen is only available after you activate MSTP on the Switch.

**Figure 47** Advanced Application > Spanning Tree Protocol > Status: MSTP

**Spanning Tree Protocol Status** Configuration RSTP MSTP

**Spanning Tree Protocol: MSTP**

**CST**

Bridge	Root	Our Bridge
Bridge ID	0-000000000000	8000-000000000000
Hello Time (second)	0	2
Max Age (second)	0	20
Forwarding Delay (second)	0	15
Cost to Bridge	0	0
Port ID	0x0000	0x0000
Configuration Name	00a0c5012346	
Revision Number	0	
Configuration Digest	AC36177F50283CD4B83821D8AB26DE62	
Topology Changed Times	0	
Time Since Last Change	0:00:00	

**Instance:**

Instance	VLAN
0	1-4094

**MSTI 1**

Bridge	Regional Root	Our Bridge
Bridge ID	0000-000000000000	8001-000000000000
Internal Cost	0	0
Port ID	0x0000	0x0000

The following table describes the labels in this screen.

**Table 26** Advanced Application > Spanning Tree Protocol > Status: MSTP

LABEL	DESCRIPTION
Configuration	Click <b>Configuration</b> to specify which STP mode you want to activate. Click <b>MSTP</b> to edit MSTP settings on the Switch.
CST	This section describes the Common Spanning Tree settings.
Bridge	<b>Root</b> refers to the base of the spanning tree (the root bridge). <b>Our Bridge</b> is this Switch. This Switch may also be the root bridge.
Bridge ID	This is the unique identifier for this bridge, consisting of bridge priority plus MAC address. This ID is the same for <b>Root</b> and <b>Our Bridge</b> if the Switch is the root switch.
Hello Time (second)	This is the time interval (in seconds) at which the root switch transmits a configuration message.
Max Age (second)	This is the maximum time (in seconds) a switch can wait without receiving a configuration message before attempting to reconfigure.
Forwarding Delay (second)	This is the time (in seconds) the root switch will wait before changing states (that is, listening to learning to forwarding).
Cost to Bridge	This is the path cost from the root port on this Switch to the root switch.

**Table 26** Advanced Application > Spanning Tree Protocol > Status: MSTP (continued)

LABEL	DESCRIPTION
Port ID	This is the priority and number of the port on the Switch through which this Switch must communicate with the root of the Spanning Tree.
Configuration Name	This field displays the configuration name for this MST region.
Revision Number	This field displays the revision number for this MST region.
Configuration Digest	A configuration digest is generated from the VLAN-MSTI mapping information. This field displays the 16-octet signature that is included in an MSTP BPDU. This field displays the digest when MSTP is activated on the system.
Topology Changed Times	This is the number of times the spanning tree has been reconfigured.
Time Since Last Change	This is the time since the spanning tree was last reconfigured.
Instance:	These fields display the MSTI to VLAN mapping. In other words, which VLANs run on each spanning tree instance.
Instance	This field displays the MSTI ID.
VLAN	This field displays which VLANs are mapped to an MSTI.
MSTI	Select the MST instance settings you want to view.
Bridge	<b>Root</b> refers to the base of the MST instance. <b>Our Bridge</b> is this Switch. This Switch may also be the root bridge.
Bridge ID	This is the unique identifier for this bridge, consisting of bridge priority plus MAC address. This ID is the same for <b>Root</b> and <b>Our Bridge</b> if the Switch is the root switch.
Internal Cost	This is the path cost from the root port in this MST instance to the regional root switch.
Port ID	This is the priority and number of the port on the Switch through which this Switch must communicate with the root of the MST instance.



# Bandwidth Control

This chapter shows you how you can cap the maximum bandwidth using the **Bandwidth Control** screen.

## 11.1 Bandwidth Control Overview

Bandwidth control means defining a maximum allowable bandwidth for incoming traffic flows on a port.

## 11.2 Bandwidth Control Setup

Click **Advanced Application > Bandwidth Control** in the navigation panel to bring up the screen as shown next.

**Figure 48** Advanced Application > Bandwidth Control

Port	Active	Ingress Rate	Scheme
*	<input type="checkbox"/>	64K bps	Drop
1	<input type="checkbox"/>	64K bps	Drop
2	<input type="checkbox"/>	64K bps	Drop
3	<input type="checkbox"/>	64K bps	Drop
4	<input type="checkbox"/>	64K bps	Drop
5	<input type="checkbox"/>	64K bps	Drop
6	<input type="checkbox"/>	64K bps	Drop
7	<input type="checkbox"/>	64K bps	Drop
8	<input type="checkbox"/>	64K bps	Drop

Apply Cancel

The following table describes the related labels in this screen.

**Table 27** Advanced Application > Bandwidth Control

LABEL	DESCRIPTION
Active	Select this check box to enable bandwidth control on the Switch. You may temporarily deactivate bandwidth control without deleting the rules configured by clearing this check box.
Port	This field displays the port number.
*	<p>Settings in this row apply to all ports. Use this row only if you want to make some settings the same for all ports. Use this row first to set the common settings and then make adjustments on a port-by-port basis.</p> <p><b>Note:</b> Changes in this row are copied to all the ports as soon as you make them.</p>
Active	Select this to activate bandwidth control on the port.
Ingress Rate	Select the maximum bandwidth allowed in kilobits per second (Kbps) for the incoming traffic flow on a port.
Scheme	<p>Select <b>Drop</b> from the drop-down list box to discard all incoming packets that are over the maximum allowable bandwidth on a port. A concentration of traffic on a port decreases port bandwidth and overflows buffer memory causing packet discards and frame losses. <b>Flow Control</b> is used to regulate transmission of signals to match the bandwidth of the receiving port. The switch uses IEEE802.3x flow control in full duplex mode and backpressure flow control in half duplex mode. IEEE802.3x flow control is used in full duplex mode to send a pause signal to the sending port, causing it to temporarily stop sending signals when the receiving port memory buffers fill. Back Pressure flow control is typically used in half duplex mode to send a "collision" signal to the sending port (mimicking a state of packet collision) causing the sending port to temporarily stop sending signals and resend later. Select this option to enable flow control.</p>
Apply	Click <b>Apply</b> to save your changes to the Switch's run-time memory. The Switch loses these changes if it is turned off or loses power, so use the <b>Save</b> link on the top navigation panel to save your changes to the non-volatile memory when you are done configuring.
Cancel	Click <b>Cancel</b> to begin configuring this screen afresh.

# Broadcast Storm Control

This chapter introduces and shows you how to configure the broadcast storm control feature.

## 12.1 Broadcast Storm Control Setup

Broadcast storm control limits the number of broadcast, multicast and DLF (destination lookup failure) packets the Switch receives per second on the ports. When the maximum number of allowable broadcast, multicast and/or DLF packets is reached per second, the subsequent packets are discarded. Enable this feature to reduce broadcast, multicast and/or DLF packets in your network. You can specify limits for each packet type on each port.

Click **Advanced Application** > **Broadcast Storm Control** in the navigation panel to display the screen as shown next.

**Figure 49** Advanced Application > Broadcast Storm Control

Port	Active
*	<input type="checkbox"/>
1	<input type="checkbox"/>
2	<input type="checkbox"/>
3	<input type="checkbox"/>
4	<input type="checkbox"/>
5	<input type="checkbox"/>
6	<input type="checkbox"/>
7	<input type="checkbox"/>
8	<input type="checkbox"/>

The following table describes the labels in this screen.

**Table 28** Advanced Application > Broadcast Storm Control

LABEL	DESCRIPTION
Active	Select this check box to enable traffic storm control on the Switch. Clear this check box to disable this feature.
Storm Control Type	Select the type(s) of packets you want to control. You can select <b>Broadcast only</b> ; <b>Broadcast and multicast</b> ; <b>Broadcast and unknown unicast</b> ; or <b>Broadcast, multicast, and unknown unicast</b> .
Packet Limit	Select the maximum number of packets of the specified type(s) that the Switch accepts each second.
Port	This field displays a port number.
*	<p>Settings in this row apply to all ports. Use this row only if you want to make some settings the same for all ports. Use this row first to set the common settings and then make adjustments on a port-by-port basis.</p> <p><b>Note:</b> Changes in this row are copied to all the ports as soon as you make them.</p>
Active	Select this to control the specified type(s) of packets on this port.
Apply	Click <b>Apply</b> to save your changes to the Switch's run-time memory. The Switch loses these changes if it is turned off or loses power, so use the <b>Save</b> link on the top navigation panel to save your changes to the non-volatile memory when you are done configuring.
Cancel	Click <b>Cancel</b> to begin configuring this screen afresh.

# Mirroring

This chapter discusses port mirroring setup screens.

## 13.1 Port Mirroring Setup

Port mirroring allows you to copy a traffic flow to a monitor port (the port you copy the traffic to) in order that you can examine the traffic from the mirrored port without interference.

Click **Advanced Application > Mirroring** in the navigation panel to display the **Mirroring** screen. Use this screen to select a monitor port and specify the traffic flow to be copied to the monitor port.

**Figure 50** Advanced Application > Mirroring

The following table describes the labels in this screen.

**Table 29** Advanced Application > Mirroring

LABEL	DESCRIPTION
Active	Select this check box to activate port mirroring on the Switch. Clear this check box to disable the feature.
Monitor Port	The monitor port is the port you copy the traffic to in order to examine it in more detail without interfering with the traffic flow on the original port. Type the port number of the monitor port.
Direction	Specify the direction of the traffic to mirror by selecting from the drop-down list box. Choices are <b>Egress</b> (outgoing), <b>Ingress</b> (incoming) and <b>Both</b> .
Mirrored Port	Select the port whose traffic (in the specified direction) you want to copy to the specified monitor port.
Apply	Click <b>Apply</b> to save your changes to the Switch's run-time memory. The Switch loses these changes if it is turned off or loses power, so use the <b>Save</b> link on the top navigation panel to save your changes to the non-volatile memory when you are done configuring.
Cancel	Click <b>Cancel</b> to begin configuring this screen afresh.



# Link Aggregation

This chapter shows you how to logically aggregate physical links to form one logical, higher-bandwidth link.

## 14.1 Link Aggregation Overview

Link aggregation (trunking) is the grouping of physical ports into one logical higher-capacity link. You may want to trunk ports if for example, it is cheaper to use multiple lower-speed links than to under-utilize a high-speed, but more costly, single-port link.

However, the more ports you aggregate then the fewer available ports you have. A trunk group is one logical link containing multiple ports.

The beginning port of each trunk group must be physically connected to form a trunk group.

The Switch supports both static and dynamic link aggregation.



---

In a properly planned network, it is recommended to implement static link aggregation only. This ensures increased network stability and control over the trunk groups on your Switch.

---

See [Section 14.6 on page 115](#) for a static port trunking example.

## 14.2 Dynamic Link Aggregation

The Switch adheres to the IEEE 802.3ad standard for static and dynamic (LACP) port trunking.

The IEEE 802.3ad standard describes the Link Aggregation Control Protocol (LACP) for dynamically creating and managing trunk groups.

When you enable LACP link aggregation on a port, the port can automatically negotiate with the ports at the remote end of a link to establish trunk groups. LACP also allows port redundancy, that is, if an operational port fails, then one of the “standby” ports become operational without user intervention. Please note that:

- You must connect all ports point-to-point to the same Ethernet switch and configure the ports for LACP trunking.

- LACP only works on full-duplex links.
- All ports in the same trunk group must have the same media type, speed, duplex mode and flow control settings.

Configure trunk groups or LACP before you connect the Ethernet switch to avoid causing network topology loops.

## 14.2.1 Link Aggregation ID

LACP aggregation ID consists of the following information<sup>1</sup>:

**Table 30** Link Aggregation ID: Local Switch

SYSTEM PRIORITY	MAC ADDRESS	KEY	PORT PRIORITY	PORT NUMBER
0000	00-00-00-00-00-00	0000	00	0000

**Table 31** Link Aggregation ID: Peer Switch

SYSTEM PRIORITY	MAC ADDRESS	KEY	PORT PRIORITY	PORT NUMBER
0000	00-00-00-00-00-00	0000	00	0000

## 14.3 Link Aggregation Status

Click **Advanced Application > Link Aggregation** in the navigation panel. The **Link Aggregation Status** screen displays by default. See [Section 14.1 on page 111](#) for more information.

**Figure 51** Advanced Application > Link Aggregation Status

Index	Enabled Ports	Synchronized Ports	Aggregator ID	Status
1	-	-	-	-
2	-	-	-	-
3	-	-	-	-
4	-	-	-	-

The following table describes the labels in this screen.

**Table 32** Advanced Application > Link Aggregation Status

LABEL	DESCRIPTION
Index	This field displays the trunk ID to identify a trunk group, that is, one logical link containing multiple ports.
Enabled Ports	These are the ports you have configured in the <b>Link Aggregation</b> screen to be in the trunk group.
Synchronized Ports	These are the ports that are currently transmitting data as one logical link in this trunk group.

1. Port Priority and Port Number are 0 as it is the aggregator ID for the trunk group, not the individual port.



**Table 32** Advanced Application > Link Aggregation Status (continued)

LABEL	DESCRIPTION
Aggregator ID	Link Aggregator ID consists of the following: system priority, MAC address, key, port priority and port number. Refer to <a href="#">Section 14.2.1 on page 112</a> for more information on this field.
Status	This field displays how these ports were added to the trunk group. It displays: <ul style="list-style-type: none"> <li>• <b>Static</b> - if the ports are configured as static members of a trunk group.</li> <li>• <b>LACP</b> - if the ports are configured to join a trunk group via LACP.</li> </ul>

## 14.4 Link Aggregation Setting

Click **Advanced Application > Link Aggregation > Link Aggregation Setting** to display the screen shown next. See [Section 14.1 on page 111](#) for more information on link aggregation.

**Figure 52** Advanced Application > Link Aggregation > Link Aggregation Setting

Group ID	Active
T1	<input type="checkbox"/>
T2	<input type="checkbox"/>
T3	<input type="checkbox"/>
T4	<input type="checkbox"/>

Port	Group
1	None ▾
2	None ▾
3	None ▾
4	None ▾
5	None ▾
6	None ▾
7	None ▾

The following table describes the labels in this screen.

**Table 33** Advanced Application > Link Aggregation > Link Aggregation Setting

LABEL	DESCRIPTION
Link Aggregation Setting	This is the only screen you need to configure to enable static link aggregation.
Group ID	The field identifies the link aggregation group, that is, one logical link containing multiple ports.

**Table 33** Advanced Application > Link Aggregation > Link Aggregation Setting (continued)

LABEL	DESCRIPTION
Active	Select this option to activate a trunk group.
Port	This field displays the port number.
Group	Select the trunk group to which a port belongs.
Apply	Click <b>Apply</b> to save your changes to the Switch's run-time memory. The Switch loses these changes if it is turned off or loses power, so use the <b>Save</b> link on the top navigation panel to save your changes to the non-volatile memory when you are done configuring.
Cancel	Click <b>Cancel</b> to begin configuring this screen afresh.

## 14.5 Link Aggregation Control Protocol

Click in the **Advanced Application > Link Aggregation > Link Aggregation Setting > LACP** to display the screen shown next. See [Section 14.2 on page 111](#) for more information on dynamic link aggregation.

**Figure 53** Advanced Application > Link Aggregation > Link Aggregation Setting > LACP

The screenshot displays the LACP configuration interface. At the top, the title is "Link Aggregation Control Protocol" and there is a link for "Link Aggregation Setting". Below the title, there are two main sections. The first section has an "Active" checkbox (unchecked) and a "System Priority" field containing the value "65535". The second section is a table with two columns: "Group ID" and "LACP Active". The table lists four groups: T1, T2, T3, and T4, each with an unchecked checkbox in the "LACP Active" column. Below this table is another table with two columns: "Port" and "LACP Timeout". The "Port" column lists ports from "\*" to 7. The "LACP Timeout" column shows a dropdown menu set to "30" seconds for each port. At the bottom of the screen, there are "Apply" and "Cancel" buttons.

The following table describes the labels in this screen.

**Table 34** Advanced Application > Link Aggregation > Link Aggregation Setting > LACP

LABEL	DESCRIPTION
Link Aggregation Control Protocol	<b>Note:</b> Do not configure this screen unless you want to enable dynamic link aggregation.
Active	Select this checkbox to enable Link Aggregation Control Protocol (LACP).
System Priority	LACP system priority is a number between 1 and 65,535. The switch with the lowest system priority (and lowest port number if system priority is the same) becomes the LACP “server”. The LACP “server” controls the operation of LACP setup. Enter a number to set the priority of an active port using Link Aggregation Control Protocol (LACP). The smaller the number, the higher the priority level.
Group ID	The field identifies the link aggregation group, that is, one logical link containing multiple ports.
LACP Active	Select this option to enable LACP for a trunk.
Port	This field displays the port number.
*	Settings in this row apply to all ports. Use this row only if you want to make some settings the same for all ports. Use this row first to set the common settings and then make adjustments on a port-by-port basis.  <b>Note:</b> Changes in this row are copied to all the ports as soon as you make them.
LACP Timeout	Timeout is the time interval between the individual port exchanges of LACP packets in order to check that the peer port in the trunk group is still up. If a port does not respond after three tries, then it is deemed to be “down” and is removed from the trunk. Set a short timeout (one second) for busy trunked links to ensure that disabled ports are removed from the trunk group as soon as possible. Select either 1 second or 30 seconds.
Apply	Click <b>Apply</b> to save your changes to the Switch’s run-time memory. The Switch loses these changes if it is turned off or loses power, so use the <b>Save</b> link on the top navigation panel to save your changes to the non-volatile memory when you are done configuring.
Cancel	Click <b>Cancel</b> to begin configuring this screen afresh.

## 14.6 Static Trunking Example

This example shows you how to create a static port trunk group for ports 2-5.

- 1 Make your physical connections** - make sure that the ports that you want to belong to the trunk group are connected to the same destination. The following figure shows ports 2-5 on switch **A** connected to switch **B**.

Figure 54 Trunking Example - Physical Connections

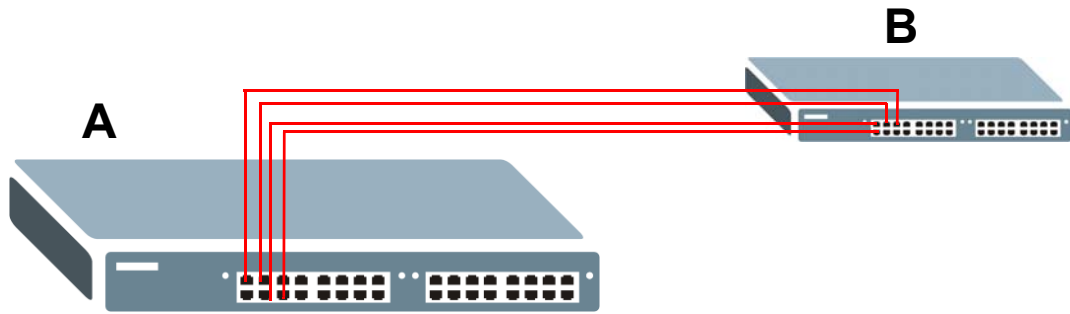

- 2 **Configure static trunking** - Click **Advanced Application > Link Aggregation > Link Aggregation Setting**. In this screen activate trunking group **T1** and select the ports that should belong to this group as shown in the figure below. Click **Apply** when you are done.

Figure 55 Trunking Example - Configuration Screen

Link Aggregation Setting Status LACP

Group ID	Active
T1	<input checked="" type="checkbox"/>
T2	<input type="checkbox"/>
T3	<input type="checkbox"/>
T4	<input type="checkbox"/>

Port	Group
1	None
2	T1
3	T1
4	T1
5	T1
6	None
7	None

example

Your trunk group 1 (**T1**) configuration is now complete; you do not need to go to any additional screens.

# Port Authentication

This chapter describes the IEEE 802.1x and MAC authentication methods.

## 15.1 Port Authentication Overview

Port authentication is a way to validate access to ports on the Switch to clients based on an external server (authentication server). The Switch supports the following methods for port authentication:

- **IEEE 802.1x<sup>2</sup>** - An authentication server validates access to a port based on a username and password provided by the user.

This type of authentication uses the RADIUS (Remote Authentication Dial In User Service, RFC 2138, 2139) protocol to validate users. See [Section 19.1.2 on page 140](#) for more information on configuring your RADIUS server settings.

### 15.1.1 IEEE 802.1x Authentication

The following figure illustrates how a client connecting to a IEEE 802.1x authentication enabled port goes through a validation process. The Switch prompts the client for login information in the form of a user name and password. When the client provides the login credentials, the Switch sends an authentication request to a RADIUS server. The RADIUS server validates whether this client is allowed access to the port.

---

2. At the time of writing, IEEE 802.1x is not supported by all operating systems. See your operating system documentation. If your operating system does not support 802.1x, then you may need to install 802.1x client software.

Figure 56 IEEE 802.1x Authentication Process

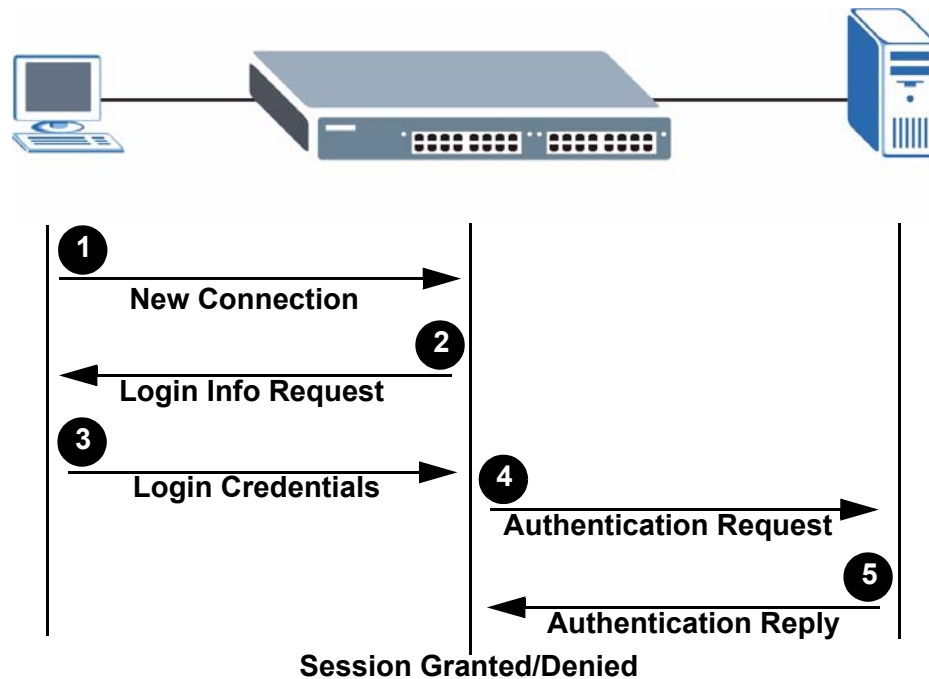

## 15.2 Port Authentication Configuration

To enable port authentication, first activate the port authentication method(s) you want to use (both on the Switch and the port(s)), then configure the RADIUS server settings in the **Auth and Acct > Radius Server Setup** screen.

To activate a port authentication method, click **Advanced Application > Port Authentication** in the navigation panel. Select a port authentication method in the screen that appears.

Figure 57 Advanced Application &gt; Port Authentication



### 15.2.1 Activate IEEE 802.1x Security

Use this screen to activate IEEE 802.1x security. In the **Port Authentication** screen click **802.1x** to display the configuration screen as shown.

**Figure 58** Advanced Application > Port Authentication > 802.1x

Port	Active	Reauthentication	Reauthentication Timer
*	<input type="checkbox"/>	On ▼	<input type="text"/> seconds
1	<input type="checkbox"/>	On ▼	3600 seconds
2	<input type="checkbox"/>	On ▼	3600 seconds
3	<input type="checkbox"/>	On ▼	3600 seconds
4	<input type="checkbox"/>	On ▼	3600 seconds
5	<input type="checkbox"/>	On ▼	3600 seconds
6	<input type="checkbox"/>	On ▼	3600 seconds
7	<input type="checkbox"/>	On ▼	3600 seconds
8	<input type="checkbox"/>	On ▼	3600 seconds

Apply Cancel

The following table describes the labels in this screen.

**Table 35** Advanced Application > Port Authentication > 802.1x

LABEL	DESCRIPTION
Active	Select this check box to permit 802.1x authentication on the Switch.  Note: You must first enable 802.1x authentication on the Switch before configuring it on each port.
Port	This field displays a port number.
*	Settings in this row apply to all ports. Use this row only if you want to make some settings the same for all ports. Use this row first to set the common settings and then make adjustments on a port-by-port basis.  Note: Changes in this row are copied to all the ports as soon as you make them.
Active	Select this to permit 802.1x authentication on this port. You must first allow 802.1x authentication on the Switch before configuring it on each port.
Reauthentication	Specify if a subscriber has to periodically re-enter his or her username and password to stay connected to the port.
Reauthentication Timer	Specify the length of time required to pass before a client has to re-enter his or her username and password to stay connected to the port.
Apply	Click <b>Apply</b> to save your changes to the Switch's run-time memory. The Switch loses these changes if it is turned off or loses power, so use the <b>Save</b> link on the top navigation panel to save your changes to the non-volatile memory when you are done configuring.
Cancel	Click <b>Cancel</b> to begin configuring this screen afresh.





# Port Security

This chapter shows you how to set up port security.

## 16.1 About Port Security

Port security allows only packets with dynamically learned MAC addresses and/or configured static MAC addresses to pass through a port on the Switch. The Switch can learn up to 16K MAC addresses in total with no limit on individual ports other than the sum cannot exceed 16K.

For maximum port security, enable this feature, disable MAC address learning and configure static MAC address(es) for a port. It is not recommended you disable port security together with MAC address learning as this will result in many broadcasts. By default, MAC address learning is still enabled even though the port security is not activated.

## 16.2 Port Security Setup

Click **Advanced Application > Port Security** in the navigation panel to display the screen as shown.

**Figure 59** Advanced Application > Port Security

The following table describes the labels in this screen.

**Table 36** Advanced Application > Port Security

LABEL	DESCRIPTION
Active	Select this option to enable port security on the Switch.
Port	This field displays a port number.
*	Settings in this row apply to all ports. Use this row only if you want to make some settings the same for all ports. Use this row first to set the common settings and then make adjustments on a port-by-port basis.  <b>Note:</b> Changes in this row are copied to all the ports as soon as you make them.
Active	Select this check box to enable the port security feature on this port. The Switch forwards packets whose MAC address(es) is in the MAC address table on this port. Packets with no matching MAC address(es) are dropped. Clear this check box to disable the port security feature. The Switch forwards all packets on this port.
Apply	Click <b>Apply</b> to save your changes to the Switch's run-time memory. The Switch loses these changes if it is turned off or loses power, so use the <b>Save</b> link on the top navigation panel to save your changes to the non-volatile memory when you are done configuring.
Cancel	Click <b>Cancel</b> to begin configuring this screen afresh.

# Queuing Method

This chapter introduces the queuing methods supported.

## 17.1 Queuing Method Overview

Queuing is used to help solve performance degradation when there is network congestion. Use the **Queuing Method** screen to configure queuing algorithms for outgoing traffic. See also **Priority Queue Assignment in Switch Setup** and **802.1p Priority in Port Setup** for related information.

Queuing algorithms allow switches to maintain separate queues for packets from each individual source or flow and prevent a source from monopolizing the bandwidth.

### 17.1.1 Strictly Priority

Strictly Priority (SP) services queues based on priority only. As traffic comes into the Switch, traffic on the highest priority queue, Q3 is transmitted first. When that queue empties, traffic on the next highest-priority queue, Q2 is transmitted until Q2 empties, and then traffic is transmitted on Q1 and so on. If higher priority queues never empty, then traffic on lower priority queues never gets sent. SP does not automatically adapt to changing network requirements.

### 17.1.2 Weighted Round Robin Scheduling (WRR)

Round Robin Scheduling services queues on a rotating basis and is activated only when a port has more traffic than it can handle. A queue is given an amount of bandwidth irrespective of the incoming traffic on that port. This queue then moves to the back of the list. The next queue is given an equal amount of bandwidth, and then moves to the end of the list; and so on, depending on the number of queues being used. This works in a looping fashion until a queue is empty.

Weighted Round Robin Scheduling (WRR) uses the same algorithm as round robin scheduling, but services queues based on their priority and queue weight (the number you configure in the queue **Weight** field) rather than a fixed amount of bandwidth. WRR is activated only when a port has more traffic than it can handle. Queues with larger weights get more service than queues with smaller weights. This queuing mechanism is highly efficient in that it divides any available bandwidth across the different traffic queues and returns to queues that have not yet emptied.

## 17.2 Configuring Queuing

Click **Advanced Application > Queuing Method** in the navigation panel.

**Figure 60** Advanced Application > Queuing Method

The following table describes the labels in this screen.

**Table 37** Advanced Application > Queuing Method

LABEL	DESCRIPTION
Method	Select <b>SPQ (Strictly Priority Queuing)</b> or <b>WRR (Weighted Round Robin)</b> . Strictly Priority services queues based on priority only. When the highest priority queue empties, traffic on the next highest-priority queue begins. Q7 has the highest priority and Q0 the lowest. Weighted Round Robin Scheduling services queues on a rotating basis based on their queue weight (the number you configure in the queue <b>Weight</b> field). Queues with larger weights get more service than queues with smaller weights.
Q0-Q3 Weight	This field is applicable only when you select <b>WRR</b> . When you select <b>WRR</b> enter the queue weight here. Bandwidth is divided across the different traffic queues according to their weights.
Apply	Click <b>Apply</b> to save your changes to the Switch's run-time memory. The Switch loses these changes if it is turned off or loses power, so use the <b>Save</b> link on the top navigation panel to save your changes to the non-volatile memory when you are done configuring.
Cancel	Click <b>Cancel</b> to begin configuring this screen afresh.

# Multicast

This chapter shows you how to configure various multicast features.

## 18.1 Multicast Overview

Traditionally, IP packets are transmitted in one of either two ways - Unicast (1 sender to 1 recipient) or Broadcast (1 sender to everybody on the network). Multicast delivers IP packets to just a group of hosts on the network.

IGMP (Internet Group Management Protocol) is a network-layer protocol used to establish membership in a multicast group - it is not used to carry user data. Refer to RFC 1112, RFC 2236 and RFC 3376 for information on IGMP versions 1, 2 and 3 respectively.

### 18.1.1 IP Multicast Addresses

In IPv4, a multicast address allows a device to send packets to a specific group of hosts (multicast group) in a different subnetwork. A multicast IP address represents a traffic receiving group, not individual receiving devices. IP addresses in the Class D range (224.0.0.0 to 239.255.255.255) are used for IP multicasting. Certain IP multicast numbers are reserved by IANA for special purposes (see the IANA website for more information).

### 18.1.2 IGMP Filtering

With the IGMP filtering feature, you can control which IGMP groups a subscriber on a port can join. This allows you to control the distribution of multicast services (such as content information distribution) based on service plans and types of subscription.

You can set the Switch to filter the multicast group join reports on a per-port basis by configuring an IGMP filtering profile and associating the profile to a port.

### 18.1.3 IGMP Snooping

The Switch can passively snoop on IGMP packets transferred between IP multicast routers/switches and IP multicast hosts to learn the IP multicast group membership. It checks IGMP packets passing through it, picks out the group registration information, and configures multicasting accordingly. IGMP snooping allows the Switch to learn multicast groups without you having to manually configure them.

The Switch forwards multicast traffic destined for multicast groups (that it has learned from IGMP snooping or that you have manually configured) to ports that are members of that group. IGMP snooping generates no additional network traffic, allowing you to significantly reduce multicast traffic passing through your Switch.

### 18.1.4 IGMP Snooping and VLANs

The Switch can perform IGMP snooping on up to 16 VLANs. You can configure the Switch to automatically learn multicast group membership of any VLANs. The Switch then performs IGMP snooping on the first 16 VLANs that send IGMP packets. This is referred to as auto mode. Alternatively, you can specify the VLANs that IGMP snooping should be performed on. This is referred to as fixed mode. In fixed mode the Switch does not learn multicast group membership of any VLANs other than those explicitly added as an IGMP snooping VLAN.

## 18.2 Multicast Status

Click **Advanced Applications > Multicast** to display the screen as shown. This screen shows the multicast group information. See [Section 18.1 on page 125](#) for more information on multicasting.

**Figure 61** Advanced Application > Multicast

Multicast Status			<a href="#">Multicast Setting</a>
Index	VID	Port	Multicast Group

The following table describes the labels in this screen.

**Table 38** Multicast Status

LABEL	DESCRIPTION
Index	This is the index number of the entry.
VID	This field displays the multicast VLAN ID.
Port	This field displays the port number that belongs to the multicast group.
Multicast Group	This field displays IP multicast group addresses.

## 18.3 Multicast Setting

Click **Advanced Applications > Multicast > Multicast Setting** link to display the screen as shown. See [Section 18.1 on page 125](#) for more information on multicasting.

**Figure 62** Advanced Application > Multicast > Multicast Setting

Port	Immed. Leave	Group Limited	Max Group Num.	IGMP Filtering Profile	IGMP Querier Mode
*	<input type="checkbox"/>	<input type="checkbox"/>		Default	Auto
1	<input type="checkbox"/>	<input type="checkbox"/>	0	Default	Auto
2	<input type="checkbox"/>	<input type="checkbox"/>	0	Default	Auto
3	<input type="checkbox"/>	<input type="checkbox"/>	0	Default	Auto
4	<input type="checkbox"/>	<input type="checkbox"/>	0	Default	Auto
5	<input type="checkbox"/>	<input type="checkbox"/>	0	Default	Auto
6	<input type="checkbox"/>	<input type="checkbox"/>	0	Default	Auto
7	<input type="checkbox"/>	<input type="checkbox"/>	0	Default	Auto

The following table describes the labels in this screen.

**Table 39** Advanced Application > Multicast > Multicast Setting

LABEL	DESCRIPTION
IGMP Snooping	Use these settings to configure IGMP Snooping.
Active	Select <b>Active</b> to enable IGMP Snooping to forward group multicast traffic only to ports that are members of that group.
Host Timeout	Specify the time (from 1 to 16 711 450) in seconds that elapses before the Switch removes an IGMP group membership entry if it does not receive report messages from the port.
Leave Timeout	Enter an IGMP leave timeout value (from 1 to 16 711 450) in seconds. This defines how many seconds the Switch waits for an IGMP report before removing an IGMP snooping membership entry when an IGMP leave message is received from a host.
802.1p Priority	Select a priority level (0-7) to which the Switch changes the priority in outgoing IGMP control packets. Otherwise, select <b>No-Change</b> to not replace the priority.
IGMP Filtering	Select <b>Active</b> to enable IGMP filtering to control which IGMP groups a subscriber on a port can join.  <b>Note:</b> If you enable IGMP filtering, you must create and assign IGMP filtering profiles for the ports that you want to allow to join multicast groups.
Unknown Multicast Frame	Specify the action to perform when the Switch receives an unknown multicast frame. Select <b>Drop</b> to discard the frame(s). Select <b>Flooding</b> to send the frame(s) to all ports.
Port	This field displays the port number.

**Table 39** Advanced Application > Multicast > Multicast Setting (continued)

LABEL	DESCRIPTION
*	<p>Settings in this row apply to all ports.</p> <p>Use this row only if you want to make some settings the same for all ports. Use this row first to set the common settings and then make adjustments on a port-by-port basis.</p> <p><b>Note:</b> Changes in this row are copied to all the ports as soon as you make them.</p>
Immed. Leave	<p>Select this option to set the Switch to remove this port from the multicast tree when an IGMP version 2 leave message is received on this port.</p> <p>Select this option if there is only one host connected to this port.</p>
Group Limited	<p>Select this option to limit the number of multicast groups this port is allowed to join.</p>
Max Group Num.	<p>Enter the number of multicast groups this port is allowed to join. Once a port is registered in the specified number of multicast groups, any new IGMP join report frame(s) is dropped on this port.</p>
IGMP Filtering Profile	<p>Select the name of the IGMP filtering profile to use for this port. Otherwise, select <b>Default</b> to prohibit the port from joining any multicast group.</p> <p>You can create IGMP filtering profiles in the <b>Multicast &gt; Multicast Setting &gt; IGMP Filtering Profile</b> screen.</p>
IGMP Querier Mode	<p>The Switch treats an IGMP query port as being connected to an IGMP multicast router (or server). The Switch forwards IGMP join or leave packets to an IGMP query port.</p> <p>Select <b>Auto</b> to have the Switch use the port as an IGMP query port if the port receives IGMP query packets.</p> <p>Select <b>Fixed</b> to have the Switch always use the port as an IGMP query port. Select this when you connect an IGMP multicast server to the port.</p> <p>Select <b>Edge</b> to stop the Switch from using the port as an IGMP query port. The Switch will not keep any record of an IGMP router being connected to this port. The Switch does not forward IGMP join or leave packets to this port.</p>
Apply	<p>Click <b>Apply</b> to save your changes to the Switch's run-time memory. The Switch loses these changes if it is turned off or loses power, so use the <b>Save</b> link on the top navigation panel to save your changes to the non-volatile memory when you are done configuring.</p>
Cancel	<p>Click <b>Cancel</b> to begin configuring this screen afresh.</p>

## 18.4 IGMP Snooping VLAN

Click **Advanced Applications > Multicast** in the navigation panel. Click the **Multicast Setting** link and then the **IGMP Snooping VLAN** link to display the screen as shown. See [Section 18.1.4 on page 126](#) for more information on IGMP Snooping VLAN.



**Figure 63** Advanced Application > Multicast > Multicast Setting > IGMP Snooping VLAN

The following table describes the labels in this screen.

**Table 40** Advanced Application > Multicast > Multicast Setting > IGMP Snooping VLAN

LABEL	DESCRIPTION
Mode	<p>Select <b>auto</b> to have the Switch learn multicast group membership information of any VLANs automatically.</p> <p>Select <b>fixed</b> to have the Switch only learn multicast group membership information of the VLAN(s) that you specify below.</p> <p>In either <b>auto</b> or <b>fixed</b> mode, the Switch can learn up to 16 VLANs (including up to three VLANs you configured in the <b>MVR</b> screen). For example, if you have configured one multicast VLAN in the <b>MVR</b> screen, you can only specify up to 15 VLANs in this screen.</p> <p>The Switch drops any IGMP control messages which do not belong to these 16 VLANs.</p> <p><b>Note:</b> You must also enable IGMP snooping in the <b>Multicast Setting</b> screen first.</p>
Apply	Click <b>Apply</b> to save your changes to the Switch's run-time memory. The Switch loses these changes if it is turned off or loses power, so use the <b>Save</b> link on the top navigation panel to save your changes to the non-volatile memory when you are done configuring.
Cancel	Click <b>Cancel</b> to begin configuring this screen afresh.
VLAN	Use this section of the screen to add VLANs upon which the Switch is to perform IGMP snooping.
Name	Enter the descriptive name of the VLAN for identification purposes.
VID	<p>Enter the ID of a static VLAN; the valid range is between 1 and 4094.</p> <p><b>Note:</b> You cannot configure the same VLAN ID as in the <b>MVR</b> screen.</p>
Add	Click <b>Add</b> to insert the entry in the summary table below and save your changes to the Switch's run-time memory. The Switch loses these changes if it is turned off or loses power, so use the <b>Save</b> link on the top navigation panel to save your changes to the non-volatile memory when you are done configuring.
Cancel	Click <b>Cancel</b> to reset the fields to your previous configuration.

**Table 40** Advanced Application > Multicast > Multicast Setting > IGMP Snooping VLAN

LABEL	DESCRIPTION
Clear	Click this to clear the fields.
Index	This is the number of the IGMP snooping VLAN entry in the table.
Name	This field displays the descriptive name for this VLAN group.
VID	This field displays the ID number of the VLAN group.
Delete	Check the rule(s) that you want to remove in the <b>Delete</b> column, then click the <b>Delete</b> button.
Cancel	Click <b>Cancel</b> to clear the <b>Delete</b> check boxes.

## 18.5 IGMP Filtering Profile

An IGMP filtering profile specifies a range of multicast groups that clients connected to the Switch are able to join. A profile contains a range of multicast IP addresses which you want clients to be able to join. Profiles are assigned to ports (in the **Multicast Setting** screen). Clients connected to those ports are then able to join the multicast groups specified in the profile. Each port can be assigned a single profile. A profile can be assigned to multiple ports.

Click **Advanced Applications > Multicast > Multicast Setting > IGMP Filtering Profile** link to display the screen as shown.

**Figure 64** Advanced Application > Multicast > Multicast Setting > IGMP Filtering Profile

The screenshot shows the 'IGMP Filtering Profile' configuration interface. At the top, there's a breadcrumb trail: 'Advanced Application > Multicast > Multicast Setting > IGMP Filtering Profile'. The main area is titled 'Profile Setup'. It contains three input fields: 'Profile Name' (empty), 'Start Address' (224.0.0.0), and 'End Address' (224.0.0.0). Below these fields are 'Add' and 'Clear' buttons. A table below shows a 'Default' profile with 'Start Address' 0.0.0.0 and 'End Address' 0.0.0.0. There are checkboxes for 'Delete Profile' and 'Delete Rule' in the table. At the bottom of the screen are 'Delete' and 'Cancel' buttons.

The following table describes the labels in this screen.

**Table 41** Advanced Application > Multicast > Multicast Setting > IGMP Filtering Profile

LABEL	DESCRIPTION
Profile Name	Enter a descriptive name for the profile for identification purposes. To configure additional rule(s) for a profile that you have already added, enter the profile name and specify a different IP multicast address range.
Start Address	Type the starting multicast IP address for a range of multicast IP addresses that you want to belong to the IGMP filter profile.
End Address	Type the ending multicast IP address for a range of IP addresses that you want to belong to the IGMP filter profile. If you want to add a single multicast IP address, enter it in both the <b>Start Address</b> and <b>End Address</b> fields.

**Table 41** Advanced Application > Multicast > Multicast Setting > IGMP Filtering Profile

LABEL	DESCRIPTION
Add	Click <b>Add</b> to save the profile to the Switch's run-time memory. The Switch loses these changes if it is turned off or loses power, so use the <b>Save</b> link on the top navigation panel to save your changes to the non-volatile memory when you are done configuring.
Clear	Click <b>Clear</b> to clear the fields to the factory defaults.
Profile Name	This field displays the descriptive name of the profile.
Start Address	This field displays the start of the multicast address range.
End Address	This field displays the end of the multicast address range.
Delete	To delete the profile(s) and all the accompanying rules, select the profile(s) that you want to remove in the <b>Delete Profile</b> column, then click the <b>Delete</b> button. To delete a rule(s) from a profile, select the rule(s) that you want to remove in the <b>Delete Rule</b> column, then click the <b>Delete</b> button.
Cancel	Click <b>Cancel</b> to clear the <b>Delete Profile/Delete Rule</b> check boxes.

## 18.6 MVR Overview

Multicast VLAN Registration (MVR) is designed for applications (such as Media-on-Demand (MoD)) that use multicast traffic across an Ethernet ring-based service provider network.

MVR allows one single multicast VLAN to be shared among different subscriber VLANs on the network. While isolated in different subscriber VLANs, connected devices can subscribe to and unsubscribe from the multicast stream in the multicast VLAN. This improves bandwidth utilization with reduced multicast traffic in the subscriber VLANs and simplifies multicast group management.

MVR only responds to IGMP join and leave control messages from multicast groups that are configured under MVR. Join and leave reports from other multicast groups are managed by IGMP snooping.

The following figure shows a network example. The subscriber VLAN (**1, 2 and 3**) information is hidden from the streaming media server, **S**. In addition, the multicast VLAN information is only visible to the Switch and **S**.

**Figure 65** MVR Network Example

### 18.6.1 Types of MVR Ports

In MVR, a source port is a port on the Switch that can send and receive multicast traffic in a multicast VLAN while a receiver port can only receive multicast traffic. Once configured, the Switch maintains a forwarding table that matches the multicast stream to the associated multicast group.

## 18.6.2 MVR Modes

You can set your Switch to operate in either dynamic or compatible mode.

In dynamic mode, the Switch sends IGMP leave and join reports to the other multicast devices (such as multicast routers or servers) in the multicast VLAN. This allows the multicast devices to update the multicast forwarding table to forward or not forward multicast traffic to the receiver ports.

In compatible mode, the Switch does not send any IGMP reports. In this case, you must manually configure the forwarding settings on the multicast devices in the multicast VLAN.

## 18.6.3 How MVR Works

The following figure shows a multicast television example where a subscriber device (such as a computer) in VLAN 1 receives multicast traffic from the streaming media server, S, via the Switch. Multiple subscriber devices can connect through a port configured as the receiver on the Switch.

When the subscriber selects a television channel, computer A sends an IGMP report to the Switch to join the appropriate multicast group. If the IGMP report matches one of the configured MVR multicast group addresses on the Switch, an entry is created in the forwarding table on the Switch. This maps the subscriber VLAN to the list of forwarding destinations for the specified multicast traffic.

When the subscriber changes the channel or turns off the computer, an IGMP leave message is sent to the Switch to leave the multicast group. The Switch sends a query to VLAN 1 on the receiver port (in this case, an uplink port on the Switch). If there is another subscriber device connected to this port in the same subscriber VLAN, the receiving port will still be on the list of forwarding destination for the multicast traffic. Otherwise, the Switch removes the receiver port from the forwarding table.

**Figure 66** MVR Multicast Television Example



## 18.7 General MVR Configuration

Use the **MVR** screen to create multicast VLANs and select the receiver port(s) and a source port for each multicast VLAN. Click **Advanced Applications > Multicast > Multicast Setting > MVR** link to display the screen as shown next.



You can create up to three multicast VLANs and up to 256 multicast rules on the Switch.



Your Switch automatically creates a static VLAN (with the same VID) when you create a multicast VLAN in this screen.

**Figure 67** Advanced Application > Multicast > Multicast Setting > MVR

The following table describes the related labels in this screen.

**Table 42** Advanced Application > Multicast > Multicast Setting > MVR

LABEL	DESCRIPTION
Active	Select this check box to enable MVR to allow one single multicast VLAN to be shared among different subscriber VLANs on the network.
Name	Enter a descriptive name (up to 32 printable ASCII characters) for identification purposes.
Multicast VLAN ID	Enter the VLAN ID (1 to 4094) of the multicast VLAN.
802.1p Priority	Select a priority level (0-7) with which the Switch replaces the priority in outgoing IGMP control packets (belonging to this multicast VLAN).
Mode	Specify the MVR mode on the Switch. Choices are <b>Dynamic</b> and <b>Compatible</b> . Select <b>Dynamic</b> to send IGMP reports to all MVR source ports in the multicast VLAN. Select <b>Compatible</b> to set the Switch not to send IGMP reports.
Port	This field displays the port number on the Switch.

**Table 42** Advanced Application > Multicast > Multicast Setting > MVR (continued)

LABEL	DESCRIPTION
*	Settings in this row apply to all ports. Use this row only if you want to make some settings the same for all ports. Use this row first to set the common settings and then make adjustments on a port-by-port basis.  <b>Note:</b> Changes in this row are copied to all the ports as soon as you make them.
Source Port	Select this option to set this port as the MVR source port that sends and receives multicast traffic. All source ports must belong to a single multicast VLAN.
Receiver Port	Select this option to set this port as a receiver port that only receives multicast traffic.
None	Select this option to set the port not to participate in MVR. No MVR multicast traffic is sent or received on this port.
Tagging	Select this checkbox if you want the port to tag the VLAN ID in all outgoing frames transmitted.
Add	Click <b>Add</b> to save your changes to the Switch's run-time memory. The Switch loses these changes if it is turned off or loses power, so use the <b>Save</b> link on the top navigation panel to save your changes to the non-volatile memory when you are done configuring.
Cancel	Click <b>Cancel</b> to begin configuring this screen afresh.
VLAN	This field displays the multicast VLAN ID.
Active	This field displays whether the multicast group is enabled or not.
Name	This field displays the descriptive name for this setting.
Mode	This field displays the MVR mode.
Source Port	This field displays the source port number(s).
Receiver Port	This field displays the receiver port number(s).
802.1p	This field displays the priority level.
Delete	To delete a multicast VLAN(s), select the rule(s) that you want to remove in the <b>Delete</b> column, then click the <b>Delete</b> button.
Cancel	Click <b>Cancel</b> to clear the <b>Delete</b> check boxes.

## 18.8 MVR Group Configuration

All source ports and receiver ports belonging to a multicast group can receive multicast data sent to this multicast group.

Configure MVR IP multicast group address(es) in the **Group Configuration** screen. Click **Group Configuration** in the **MVR** screen.



A port can belong to more than one multicast VLAN. However, IP multicast group addresses in different multicast VLANs cannot overlap.

**Figure 68** Advanced Application > Multicast > Multicast Setting > MVR: Group Configuration

The following table describes the labels in this screen.

**Table 43** Advanced Application > Multicast > Multicast Setting > MVR: Group Configuration

LABEL	DESCRIPTION
Multicast VLAN ID	Select a multicast VLAN ID (that you configured in the <b>MVR</b> screen) from the drop-down list box.
Name	Enter a descriptive name for identification purposes.
Start Address	Enter the starting IP multicast address of the multicast group in dotted decimal notation. Refer to <a href="#">Section 18.1.1 on page 125</a> for more information on IP multicast addresses.
End Address	Enter the ending IP multicast address of the multicast group in dotted decimal notation. Enter the same IP address as the <b>Start Address</b> field if you want to configure only one IP address for a multicast group. Refer to <a href="#">Section 18.1.1 on page 125</a> for more information on IP multicast addresses.
Add	Click <b>Add</b> to save your changes to the Switch's run-time memory. The Switch loses these changes if it is turned off or loses power, so use the <b>Save</b> link on the top navigation panel to save your changes to the non-volatile memory when you are done configuring.
Cancel	Click <b>Cancel</b> to begin configuring this screen afresh.
MVLAN	This field displays the multicast VLAN ID.
Name	This field displays the descriptive name for this setting.
Start Address	This field displays the starting IP address of the multicast group.
End Address	This field displays the ending IP address of the multicast group.
Delete	Select <b>Delete All</b> or <b>Delete Group</b> and click <b>Delete</b> to remove the selected entry(ies) from the table.
Cancel	Select <b>Cancel</b> to clear the checkbox(es) in the table.

### 18.8.1 MVR Configuration Example

The following figure shows a network example where ports 1, 2 and 3 on the Switch belong to VLAN 1. In addition, port 7 belongs to the multicast group with VID 200 to receive multicast traffic (the **News** and **Movie** channels) from the remote streaming media server, **S**. Computers A, B and C in VLAN 1 are able to receive the traffic.

**Figure 69** MVR Configuration Example

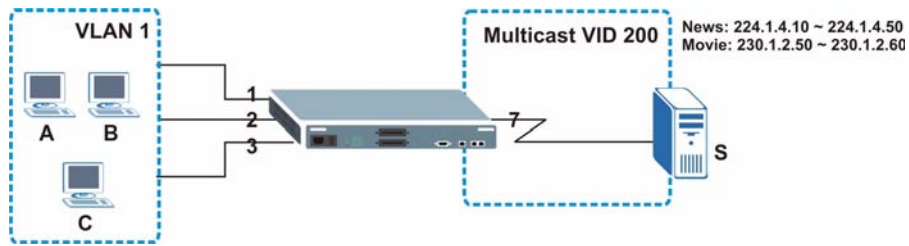

To configure the MVR settings on the Switch, create a multicast group in the **MVR** screen and set the receiver and source ports.

**Figure 70** MVR Configuration Example

The screenshot shows the MVR configuration interface. At the top, there are tabs for 'MVR', 'Multicast Setting', and 'Group Configuration'. The 'Multicast Setting' tab is selected. The configuration fields are as follows:

- Active:
- Name: Premium
- Multicast VLAN ID: 200
- 802.1p Priority: 0
- Mode:  Dynamic  Compatible

Below the settings is a table for port configuration:

Port	Source Port	Receiver Port	None	Tagging
*		None		<input type="checkbox"/>
1	<input type="radio"/>	<input checked="" type="radio"/>	<input type="radio"/>	<input type="checkbox"/>
2	<input type="radio"/>	<input checked="" type="radio"/>	<input type="radio"/>	<input type="checkbox"/>
3	<input type="radio"/>	<input checked="" type="radio"/>	<input type="radio"/>	<input type="checkbox"/>
4	<input type="radio"/>	<input type="radio"/>	<input checked="" type="radio"/>	<input type="checkbox"/>
5	<input type="radio"/>	<input type="radio"/>	<input checked="" type="radio"/>	<input type="checkbox"/>
6	<input type="radio"/>	<input type="radio"/>	<input checked="" type="radio"/>	<input type="checkbox"/>
7	<input checked="" type="radio"/>	<input type="radio"/>	<input type="radio"/>	<input checked="" type="checkbox"/>
8	<input type="radio"/>	<input type="radio"/>	<input checked="" type="radio"/>	<input type="checkbox"/>
9	<input type="radio"/>	<input type="radio"/>	<input checked="" type="radio"/>	<input type="checkbox"/>
10	<input type="radio"/>	<input type="radio"/>	<input checked="" type="radio"/>	<input type="checkbox"/>

Red circles highlight the 'Name', 'Multicast VLAN ID', and 'Mode' fields in the settings section. Red circles also highlight the rows for ports 1-3, 7, and 8 in the table. The word 'example' is written in red next to the Tagging checkbox for port 7.

To set the Switch to forward the multicast group traffic to the subscribers, configure multicast group settings in the **Group Configuration** screen. The following figure shows an example where two multicast groups (**News** and **Movie**) are configured for the multicast VLAN 200.



Figure 71 MVR Group Configuration Example

Group Configuration MVR

Multicast VLAN ID

---

Name	Start Address	End Address
<input type="text" value="Movie"/>	<input type="text" value="230.1.2.50"/>	<input type="text" value="230.1.2.60"/>

MVLAN	Name	Start Address	End Address	Delete All	Delete Group
200	News	224.1.4.10	224.1.4.50	<input type="checkbox"/>	<input type="checkbox"/>

example

Figure 72 MVR Group Configuration Example

Group Configuration MVR

Multicast VLAN ID

---

Name	Start Address	End Address
<input type="text"/>	<input type="text" value="0.0.0.0"/>	<input type="text" value="0.0.0.0"/>

MVLAN	Name	Start Address	End Address	Delete All	Delete Group
200	Movie	230.1.2.50	230.1.2.60	<input type="checkbox"/>	<input type="checkbox"/>
	News	224.1.4.10	224.1.4.50	<input type="checkbox"/>	<input type="checkbox"/>

example



# Authentication & Accounting

This chapter describes how to configure authentication and accounting settings on the Switch.

## 19.1 Authentication, Authorization and Accounting

Authentication is the process of determining who a user is and validating access to the Switch. The Switch can authenticate users who try to log in based on user accounts configured on the Switch itself. The Switch can also use an external authentication server to authenticate a large number of users.

Authorization is the process of determining what a user is allowed to do. Different user accounts may have higher or lower privilege levels associated with them. For example, user A may have the right to create new login accounts on the Switch but user B cannot. The Switch can authorize users based on user accounts configured on the Switch itself or it can use an external server to authorize a large number of users.

Accounting is the process of recording what a user is doing. The Switch can use an external server to track when users log in, log out, execute commands and so on. Accounting can also record system related actions such as boot up and shut down times of the Switch.

The external servers that perform authentication, authorization and accounting functions are known as AAA servers. The Switch supports RADIUS (Remote Authentication Dial-In User Service, see [Section 19.1.2 on page 140](#)) and TACACS+ (Terminal Access Controller Access-Control System Plus, see [Section 19.1.2 on page 140](#)) as external authentication, authorization and accounting servers.

**Figure 73** AAA Server



### 19.1.1 Local User Accounts

By storing user profiles locally on the Switch, your Switch is able to authenticate and authorize users without interacting with a network AAA server. However, there is a limit on the number of users you may authenticate in this way (See [Chapter 25 on page 181](#)).

## 19.1.2 RADIUS and TACACS+

RADIUS and TACACS+ are security protocols used to authenticate users by means of an external server instead of (or in addition to) an internal device user database that is limited to the memory capacity of the device. In essence, RADIUS and TACACS+ authentication both allow you to validate an unlimited number of users from a central location.

The following table describes some key differences between RADIUS and TACACS+.

**Table 44** RADIUS vs TACACS+

	RADIUS	TACACS+
Transport Protocol	UDP (User Datagram Protocol)	TCP (Transmission Control Protocol)
Encryption	Encrypts the password sent for authentication.	All communication between the client (the Switch) and the TACACS server is encrypted.

## 19.2 Authentication and Accounting Screens

To enable authentication, accounting or both on the Switch. First, configure your authentication server settings (RADIUS, TACACS+ or both) and then set up the authentication priority and accounting settings.

Click **Advanced Application > Auth and Acct** in the navigation panel to display the screen as shown.

**Figure 74** Advanced Application > Auth and Acct



### 19.2.1 RADIUS Server Setup

Use this screen to configure your RADIUS server settings. See [Section 19.1.2 on page 140](#) for more information on RADIUS servers. Click on the **RADIUS Server Setup** link in the **Authentication and Accounting** screen to view the screen as shown.

**Figure 75** Advanced Application > Auth and Acct > RADIUS Server Setup

**RADIUS Server Setup**
Auth and Acct

---

**Authentication Server**

Mode: index-priority

Timeout: 30 seconds

Index	IP Address	UDP Port	Shared Secret	Delete
1	0.0.0.0	1812		<input type="checkbox"/>
2	0.0.0.0	1812		<input type="checkbox"/>

Apply
Cancel

**Accounting Server**

Timeout: 30 seconds

Index	IP Address	UDP Port	Shared Secret	Delete
1	0.0.0.0	1813		<input type="checkbox"/>
2	0.0.0.0	1813		<input type="checkbox"/>

Apply
Cancel

The following table describes the labels in this screen.

**Table 45** Advanced Application > Auth and Acct > RADIUS Server Setup

LABEL	DESCRIPTION
Authentication Server	Use this section to configure your RADIUS authentication settings.
Mode	This field only applies if you configure multiple RADIUS servers. Select <b>index-priority</b> and the Switch tries to authenticate with the first configured RADIUS server, if the RADIUS server does not respond then the Switch tries to authenticate with the second RADIUS server. Select <b>round-robin</b> to alternate between the RADIUS servers that it sends authentication requests to.
Timeout	Specify the amount of time in seconds that the Switch waits for an authentication request response from the RADIUS server. If you are using <b>index-priority</b> for your authentication and you are using two RADIUS servers then the timeout value is divided between the two RADIUS servers. For example, if you set the timeout value to 30 seconds, then the Switch waits for a response from the first RADIUS server for 15 seconds and then tries the second RADIUS server.
Index	This is a read-only number representing a RADIUS server entry.
IP Address	Enter the IP address of an external RADIUS server in dotted decimal notation.
UDP Port	The default port of a RADIUS server for authentication is <b>1812</b> . You need not change this value unless your network administrator instructs you to do so.
Shared Secret	Specify a password (up to 32 alphanumeric characters) as the key to be shared between the external RADIUS server and the Switch. This key is not sent over the network. This key must be the same on the external RADIUS server and the Switch.

**Table 45** Advanced Application > Auth and Acct > RADIUS Server Setup (continued)

LABEL	DESCRIPTION
Delete	Check this box if you want to remove an existing RADIUS server entry from the Switch. This entry is deleted when you click <b>Apply</b> .
Apply	Click <b>Apply</b> to save your changes to the Switch's run-time memory. The Switch loses these changes if it is turned off or loses power, so use the <b>Save</b> link on the top navigation panel to save your changes to the non-volatile memory when you are done configuring.
Cancel	Click <b>Cancel</b> to begin configuring this screen afresh.
Accounting Server	Use this section to configure your RADIUS accounting server settings.
Timeout	Specify the amount of time in seconds that the Switch waits for an accounting request response from the RADIUS accounting server.
Index	This is a read-only number representing a RADIUS accounting server entry.
IP Address	Enter the IP address of an external RADIUS accounting server in dotted decimal notation.
UDP Port	The default port of a RADIUS accounting server for accounting is <b>1813</b> . You need not change this value unless your network administrator instructs you to do so.
Shared Secret	Specify a password (up to 32 alphanumeric characters) as the key to be shared between the external RADIUS accounting server and the Switch. This key is not sent over the network. This key must be the same on the external RADIUS accounting server and the Switch.
Delete	Check this box if you want to remove an existing RADIUS accounting server entry from the Switch. This entry is deleted when you click <b>Apply</b> .
Apply	Click <b>Apply</b> to save your changes to the Switch's run-time memory. The Switch loses these changes if it is turned off or loses power, so use the <b>Save</b> link on the top navigation panel to save your changes to the non-volatile memory when you are done configuring.
Cancel	Click <b>Cancel</b> to begin configuring this screen afresh.

## 19.2.2 TACACS+ Server Setup

Use this screen to configure your TACACS+ server settings. See [Section 19.1.2 on page 140](#) for more information on TACACS+ servers. Click on the **TACACS+ Server Setup** link in the **Authentication and Accounting** screen to view the screen as shown.

**Figure 76** Advanced Application > Auth and Acct > TACACS+ Server Setup

**TACACS+ Server Setup**
Auth and Acct

---

**Authentication Server**

Mode: index-priority

Timeout: 30 seconds

Index	IP Address	TCP Port	Shared Secret	Delete
1	<span style="border: 1px solid gray; padding: 2px;">0.0.0.0</span>	<span style="border: 1px solid gray; padding: 2px;">49</span>	<span style="border: 1px solid gray; padding: 2px;"></span>	<input type="checkbox"/>
2	<span style="border: 1px solid gray; padding: 2px;">0.0.0.0</span>	<span style="border: 1px solid gray; padding: 2px;">49</span>	<span style="border: 1px solid gray; padding: 2px;"></span>	<input type="checkbox"/>

Apply
Cancel

---

**Accounting Server**

Timeout: 30 seconds

Index	IP Address	TCP Port	Shared Secret	Delete
1	<span style="border: 1px solid gray; padding: 2px;">0.0.0.0</span>	<span style="border: 1px solid gray; padding: 2px;">49</span>	<span style="border: 1px solid gray; padding: 2px;"></span>	<input type="checkbox"/>
2	<span style="border: 1px solid gray; padding: 2px;">0.0.0.0</span>	<span style="border: 1px solid gray; padding: 2px;">49</span>	<span style="border: 1px solid gray; padding: 2px;"></span>	<input type="checkbox"/>

Apply
Cancel

The following table describes the labels in this screen.

**Table 46** Advanced Application > Auth and Acct > TACACS+ Server Setup

LABEL	DESCRIPTION
Authentication Server	Use this section to configure your TACACS+ authentication settings.
Mode	This field is only valid if you configure multiple TACACS+ servers. Select <b>index-priority</b> and the Switch tries to authenticate with the first configured TACACS+ server, if the TACACS+ server does not respond then the Switch tries to authenticate with the second TACACS+ server. Select <b>round-robin</b> to alternate between the TACACS+ servers that it sends authentication requests to.
Timeout	Specify the amount of time in seconds that the Switch waits for an authentication request response from the TACACS+ server. If you are using <b>index-priority</b> for your authentication and you are using two TACACS+ servers then the timeout value is divided between the two TACACS+ servers. For example, if you set the timeout value to 30 seconds, then the Switch waits for a response from the first TACACS+ server for 15 seconds and then tries the second TACACS+ server.
Index	This is a read-only number representing a TACACS+ server entry.
IP Address	Enter the IP address of an external TACACS+ server in dotted decimal notation.
TCP Port	The default port of a TACACS+ server for authentication is <b>49</b> . You need not change this value unless your network administrator instructs you to do so.

**Table 46** Advanced Application > Auth and Acct > TACACS+ Server Setup (continued)

LABEL	DESCRIPTION
Shared Secret	Specify a password (up to 32 alphanumeric characters) as the key to be shared between the external TACACS+ server and the Switch. This key is not sent over the network. This key must be the same on the external TACACS+ server and the Switch.
Delete	Check this box if you want to remove an existing TACACS+ server entry from the Switch. This entry is deleted when you click <b>Apply</b> .
Apply	Click <b>Apply</b> to save your changes to the Switch's run-time memory. The Switch loses these changes if it is turned off or loses power, so use the <b>Save</b> link on the top navigation panel to save your changes to the non-volatile memory when you are done configuring.
Cancel	Click <b>Cancel</b> to begin configuring this screen afresh.
Accounting Server	Use this section to configure your TACACS+ accounting settings.
Timeout	Specify the amount of time in seconds that the Switch waits for an accounting request response from the TACACS+ server.
Index	This is a read-only number representing a TACACS+ accounting server entry.
IP Address	Enter the IP address of an external TACACS+ accounting server in dotted decimal notation.
TCP Port	The default port of a TACACS+ accounting server is <b>49</b> . You need not change this value unless your network administrator instructs you to do so.
Shared Secret	Specify a password (up to 32 alphanumeric characters) as the key to be shared between the external TACACS+ accounting server and the Switch. This key is not sent over the network. This key must be the same on the external TACACS+ accounting server and the Switch.
Delete	Check this box if you want to remove an existing TACACS+ accounting server entry from the Switch. This entry is deleted when you click <b>Apply</b> .
Apply	Click <b>Apply</b> to save your changes to the Switch's run-time memory. The Switch loses these changes if it is turned off or loses power, so use the <b>Save</b> link on the top navigation panel to save your changes to the non-volatile memory when you are done configuring.
Cancel	Click <b>Cancel</b> to begin configuring this screen afresh.

### 19.2.3 Authentication and Accounting Setup

Use this screen to configure authentication and accounting settings on the Switch. Click on the **Auth and Acct Setup** link in the **Authentication and Accounting** screen to view the screen as shown.



**Figure 77** Advanced Application > Auth and Acct > Auth and Acct Setup

**Auth and Acct Setup** Auth and Acct

**Authentication**

Type	Method 1	Method 2	Method 3
Privilege Enable	local	-	-
Login	local	-	-

**Accounting**

Update Period:  minutes

Type	Active	Broadcast	Mode	Method	Privilege
System	<input type="checkbox"/>	<input type="checkbox"/>	-	radius	-
Exec	<input type="checkbox"/>	<input type="checkbox"/>	start-stop	radius	-
Dot1x	<input type="checkbox"/>	<input type="checkbox"/>	start-stop	radius	-
Commands	<input type="checkbox"/>	<input type="checkbox"/>	stop-only	tacacs+	0

Apply Cancel

The following table describes the labels in this screen.

**Table 47** Advanced Application > Auth and Acct > Auth and Acct Setup

LABEL	DESCRIPTION
Authentication	Use this section to specify the methods used to authenticate users accessing the Switch.
Privilege Enable	<p>These fields specify which database the Switch should use (first, second and third) to authenticate access privilege level for administrator accounts (users for Switch management).</p> <p>Configure the access privilege of accounts via commands (see the CLI reference guide) for <b>local</b> authentication. The <b>TACACS+</b> and <b>RADIUS</b> are external servers. Before you specify the priority, make sure you have set up the corresponding database correctly first.</p> <p>You can specify up to three methods for the Switch to authenticate the access privilege level of administrators. The Switch checks the methods in the order you configure them (first <b>Method 1</b>, then <b>Method 2</b> and finally <b>Method 3</b>). You must configure the settings in the <b>Method 1</b> field. If you want the Switch to check other sources for access privilege level specify them in <b>Method 2</b> and <b>Method 3</b> fields.</p> <p>Select <b>local</b> to have the Switch check the access privilege configured for local authentication.</p> <p>Select <b>radius</b> or <b>tacacs+</b> to have the Switch check the access privilege via the external servers.</p>

**Table 47** Advanced Application > Auth and Acct > Auth and Acct Setup (continued)

LABEL	DESCRIPTION
Login	<p>These fields specify which database the Switch should use (first, second and third) to authenticate administrator accounts (users for Switch management).</p> <p>Configure the local user accounts in the <b>Access Control &gt; Logins</b> screen. The TACACS+ and RADIUS are external servers. Before you specify the priority, make sure you have set up the corresponding database correctly first.</p> <p>You can specify up to three methods for the Switch to authenticate administrator accounts. The Switch checks the methods in the order you configure them (first <b>Method 1</b>, then <b>Method 2</b> and finally <b>Method 3</b>). You must configure the settings in the <b>Method 1</b> field. If you want the Switch to check other sources for administrator accounts, specify them in <b>Method 2</b> and <b>Method 3</b> fields.</p> <p>Select <b>local</b> to have the Switch check the administrator accounts configured in the <b>Access Control &gt; Logins</b> screen.</p> <p>Select <b>radius</b> to have the Switch authenticate the administrator accounts through a RADIUS server.</p> <p>Select <b>tacacs+</b> to have the Switch authenticate the administrator accounts through a TACACS+ server.</p>
Accounting	Use this section to configure accounting settings on the Switch.
Update Period	This is the amount of time in minutes before the Switch sends an update to the accounting server. This is only valid if you select the <b>start-stop</b> option for the <b>Exec</b> or <b>Dot1x</b> entries.
Type	<p>The Switch supports the following types of events to be sent to the accounting server(s):</p> <ul style="list-style-type: none"> <li>• <b>System</b> - Configure the Switch to send information when the following system events occur: system boots up, system shuts down, system accounting is enabled, system accounting is disabled</li> <li>• <b>Exec</b> - Configure the Switch to send information when an administrator logs in and logs out via the console port, telnet or SSH.</li> <li>• <b>Dot1x</b> - Configure the Switch to send information when an IEEE 802.1x client begins a session (authenticates via the Switch), ends a session as well as interim updates of a session.</li> <li>• <b>Commands</b> - Configure the Switch to send information when commands of specified privilege level and higher are executed on the Switch.</li> </ul>
Active	Select this to activate accounting for a specified event types.
Broadcast	<p>Select this to have the Switch send accounting information to all configured accounting servers at the same time.</p> <p>If you don't select this and you have two accounting servers set up, then the Switch sends information to the first accounting server and if it doesn't get a response from the accounting server then it tries the second accounting server.</p>
Mode	<p>The Switch supports two modes of recording login events. Select:</p> <ul style="list-style-type: none"> <li>• <b>start-stop</b> - to have the Switch send information to the accounting server when a user begins a session, during a user's session (if it lasts past the <b>Update Period</b>), and when a user ends a session.</li> <li>• <b>stop-only</b> - to have the Switch send information to the accounting server only when a user ends a session.</li> </ul>
Method	<p>Select whether you want to use RADIUS or TACACS+ for accounting of specific types of events.</p> <p>TACACS+ is the only method for recording <b>Commands</b> type of event.</p>
Privilege	This field is only configurable for <b>Commands</b> type of event. Select the threshold command privilege level for which the Switch should send accounting information. The Switch will send accounting information when commands at the level you specify and higher are executed on the Switch.

**Table 47** Advanced Application > Auth and Acct > Auth and Acct Setup (continued)

LABEL	DESCRIPTION
Apply	Click <b>Apply</b> to save your changes to the Switch's run-time memory. The Switch loses these changes if it is turned off or loses power, so use the <b>Save</b> link on the top navigation panel to save your changes to the non-volatile memory when you are done configuring.
Cancel	Click <b>Cancel</b> to begin configuring this screen afresh.

## 19.2.4 Vendor Specific Attribute

RFC 2865 standard specifies a method for sending vendor-specific information between a RADIUS server and a network access device (for example, the Switch). A company can create Vendor Specific Attributes (VSAs) to expand the functionality of a RADIUS server.

The Switch supports VSAs that allow you to perform the following actions based on user authentication:

- Limit bandwidth on incoming or outgoing traffic for the port the user connects to.
- Assign account privilege levels (See [the CLI reference guide](#) for more information on account privilege levels) for the authenticated user.

The VSAs are composed of the following:

- **Vendor-ID:** An identification number assigned to the company by the IANA (Internet Assigned Numbers Authority). ZyXEL's vendor ID is 890.
- **Vendor-Type:** A vendor specified attribute, identifying the setting you want to modify.
- **Vendor-data:** A value you want to assign to the setting.



Refer to the documentation that comes with your RADIUS server on how to configure VSAs for users authenticating via the RADIUS server.

The following table describes the VSAs supported on the Switch.

**Table 48** Supported VSAs

FUNCTION	ATTRIBUTE
Ingress Bandwidth Assignment	Vendor-Id = <b>890</b> Vendor-Type = <b>1</b> Vendor-data = ingress rate (Kbps in decimal format)

**Table 48** Supported VSAs

FUNCTION	ATTRIBUTE
Egress Bandwidth Assignment	Vendor-Id = <b>890</b> Vendor-Type = <b>2</b> Vendor-data = egress rate (Kbps in decimal format)
Privilege Assignment	Vendor-ID = <b>890</b> Vendor-Type = <b>3</b> Vendor-Data = " <b>shell:priv-lvl=N</b> " or Vendor-ID = <b>9</b> (CISCO) Vendor-Type = <b>1</b> (CISCO-AVPAIR) Vendor-Data = " <b>shell:priv-lvl=N</b> " where N is a privilege level (from 0 to 14).  Note: If you set the privilege level of a login account differently on the RADIUS server(s) and the Switch, the user is assigned a privilege level from the database (RADIUS or local) the Switch uses first for user authentication.

### 19.2.5 Tunnel Protocol Attribute

You can configure tunnel protocol attributes on the RADIUS server (refer to your RADIUS server documentation) to assign a port on the Switch to a VLAN based on IEEE 802.1x authentication. The port VLAN settings are fixed and untagged. This will also set the port's VID. The following table describes the values you need to configure. Note that the bolded values in the table are fixed values as defined in RFC 3580.

**Table 49** Supported Tunnel Protocol Attribute

FUNCTION	ATTRIBUTE
VLAN Assignment	Tunnel-Type = <b>VLAN (13)</b> Tunnel-Medium-Type = <b>802 (6)</b> Tunnel-Private-Group-ID = VLAN ID  Note: You must also create a VLAN with the specified VID on the Switch.

## 19.3 Supported RADIUS Attributes

Remote Authentication Dial-In User Service (RADIUS) attributes are data used to define specific authentication, and accounting elements in a user profile, which is stored on the RADIUS server. This section lists the RADIUS attributes supported by the Switch.

Refer to RFC 2865 for more information about RADIUS attributes used for authentication. Refer to RFC 2866 and RFC 2869 for RADIUS attributes used for accounting.

This section lists the attributes used by authentication and accounting functions on the Switch. In cases where the attribute has a specific format associated with it, the format is specified.

## 19.3.1 Attributes Used for Authentication

The following sections list the attributes sent from the Switch to the RADIUS server when performing authentication.

### 19.3.1.1 Attributes Used for Authenticating Privilege Access

User-Name

- The format of the User-Name attribute is **Senab#\$**, where # is the privilege level (1~14)

User-Password

NAS-Identifier

NAS-IP-Address

### 19.3.1.2 Attributes Used to Login Users

User-Name

User-Password

NAS-Identifier

NAS-IP-Address

### 19.3.1.3 Attributes Used by the IEEE 802.1x Authentication

User-Name

NAS-Identifier

NAS-IP-Address

NAS-Port

NAS-Port-Type

- This value is set to **Ethernet(15)** on the Switch.

Calling-Station-Id

Frame-MTU

EAP-Message

State

Message-Authenticator

## 19.3.2 Attributes Used for Accounting

The following sections list the attributes sent from the Switch to the RADIUS server when performing authentication.

### 19.3.2.1 Attributes Used for Accounting System Events

NAS-IP-Address

NAS-Identifier

Acct-Status-Type

Acct-Session-ID

- The format of Acct-Session-Id is **date+time+8-digit sequential number**, for example, 2007041917210300000001. (date: 2007/04/19, time: 17:21:03, serial number: 00000001)

Acct-Delay-Time

### 19.3.2.2 Attributes Used for Accounting Exec Events

The attributes are listed in the following table along with the time that they are sent (the difference between Console and Telnet/SSH Exec events is that the Telnet/SSH events utilize the Calling-Station-Id attribute):

**Table 50** RADIUS Attributes - Exec Events via Console

ATTRIBUTE	START	INTERIM-UPDATE	STOP
User-Name	a	a	a
NAS-Identifier	a	a	a
NAS-IP-Address	a	a	a
Service-Type	a	a	a
Acct-Status-Type	a	a	a
Acct-Delay-Time	a	a	a
Acct-Session-Id	a	a	a
Acct-Authentic	a	a	a
Acct-Session-Time		a	a
Acct-Terminate-Cause			a

**Table 51** RADIUS Attributes - Exec Events via Telnet/SSH

ATTRIBUTE	START	INTERIM-UPDATE	STOP
User-Name	a	a	a
NAS-Identifier	a	a	a
NAS-IP-Address	a	a	a
Service-Type	a	a	a
Calling-Station-Id	a	a	a
Acct-Status-Type	a	a	a
Acct-Delay-Time	a	a	a
Acct-Session-Id	a	a	a
Acct-Authentic	a	a	a
Acct-Session-Time		a	a
Acct-Terminate-Cause			a

### 19.3.2.3 Attributes Used for Accounting IEEE 802.1x Events

The attributes are listed in the following table along with the time of the session they are sent:

**Table 52** RADIUS Attributes - Exec Events via Console

ATTRIBUTE	START	INTERIM-UPDATE	STOP
User-Name	a	a	a
NAS-IP-Address	a	a	a
NAS-Port	a	a	a
Class	a	a	a
Called-Station-Id	a	a	a
Calling-Station-Id	a	a	a
NAS-Identifier	a	a	a

**Table 52** RADIUS Attributes - Exec Events via Console

ATTRIBUTE	START	INTERIM-UPDATE	STOP
NAS-Port-Type	a	a	a
Acct-Status-Type	a	a	a
Acct-Delay-Time	a	a	a
Acct-Session-Id	a	a	a
Acct-Authentic	a	a	a
Acct-Input-Octets		a	a
Acct-Output-Octets		a	a
Acct-Session-Time		a	a
Acct-Input-Packets		a	a
Acct-Output-Packets		a	a
Acct-Terminate-Cause			a
Acct-Input-Gigawords		a	a
Acct-Output-Gigawords		a	a





# Loop Guard

This chapter shows you how to configure the Switch to guard against loops on the edge of your network.

## 20.1 Loop Guard Overview

Loop guard allows you to configure the Switch to shut down a port if it detects that packets sent out on that port loop back to the Switch. While you can use Spanning Tree Protocol (STP) to prevent loops in the core of your network, STP cannot prevent loops that occur on the edge of your network.

**Figure 78** Loop Guard vs STP

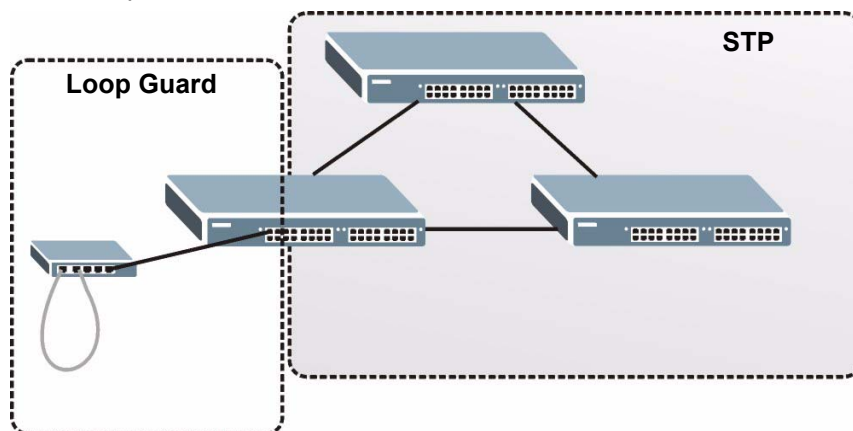

Loop guard is designed to handle loop problems on the edge of your network. This can occur when a port is connected to a Switch that is in a loop state. Loop state occurs as a result of human error. It happens when two ports on a switch are connected with the same cable. When a switch in loop state sends out broadcast messages the messages loop back to the switch and are re-broadcast again and again causing a broadcast storm.

If a switch (not in loop state) connects to a switch in loop state, then it will be affected by the switch in loop state in the following way:

- It will receive broadcast messages sent out from the switch in loop state.
- It will receive its own broadcast messages that it sends out as they loop back. It will then re-broadcast those messages again.

The following figure shows port **N** on switch **A** connected to switch **B**. Switch **B** is in loop state. When broadcast or multicast packets leave port **N** and reach switch **B**, they are sent back to port **N** on **A** as they are rebroadcast from **B**.

**Figure 79** Switch in Loop State

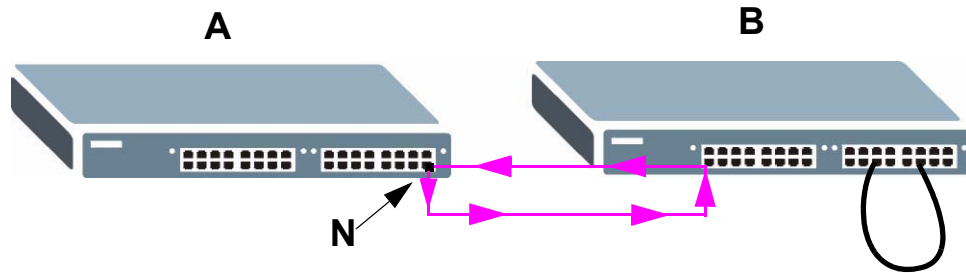

The loop guard feature checks to see if a loop guard enabled port is connected to a switch in loop state. This is accomplished by periodically sending a probe packet and seeing if the packet returns on the same port. If this is the case, the Switch will shut down the port connected to the switch in loop state.

The following figure shows a loop guard enabled port **N** on switch **A** sending a probe packet **P** to switch **B**. Since switch **B** is in loop state, the probe packet **P** returns to port **N** on **A**. The Switch then shuts down port **N** to ensure that the rest of the network is not affected by the switch in loop state.

**Figure 80** Loop Guard - Probe Packet

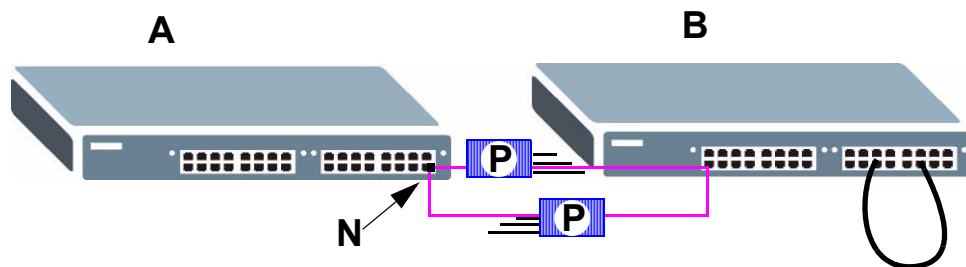

The Switch also shuts down port **N** if the probe packet returns to switch **A** on any other port. In other words loop guard also protects against standard network loops. The following figure illustrates three switches forming a loop. A sample path of the loop guard probe packet is also shown. In this example, the probe packet is sent from port **N** and returns on another port. As long as loop guard is enabled on port **N**. The Switch will shut down port **N** if it detects that the probe packet has returned to the Switch.

**Figure 81** Loop Guard - Network Loop

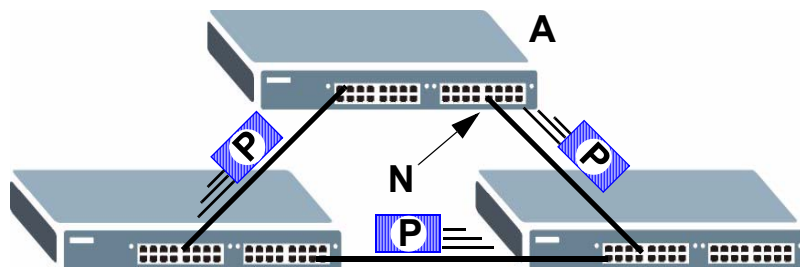



After resolving the loop problem on your network you can re-activate the disabled port via the web configurator (see [Section 7.7 on page 72](#)) or via commands (see [the CLI reference guide](#)).

## 20.2 Loop Guard Setup

Click **Advanced Application > Loop Guard** in the navigation panel to display the screen as shown.



The loop guard feature can not be enabled on the ports that have Spanning Tree Protocol (RSTP, MRSTP or MSTP) enabled.

**Figure 82** Advanced Application > Loop Guard

Port	Active
*	<input type="checkbox"/>
1	<input type="checkbox"/>
2	<input type="checkbox"/>
3	<input type="checkbox"/>
4	<input type="checkbox"/>
5	<input type="checkbox"/>
6	<input type="checkbox"/>
7	<input type="checkbox"/>
8	<input type="checkbox"/>

The following table describes the labels in this screen.

**Table 53** Advanced Application > Loop Guard

LABEL	DESCRIPTION
Active	Select this option to enable loop guard on the Switch. The Switch generates syslog, internal log messages as well as SNMP traps when it shuts down a port via the loop guard feature.
Port	This field displays a port number.
*	Use this row to make the setting the same for all ports. Use this row first and then make adjustments on a port-by-port basis.  Note: Changes in this row are copied to all the ports as soon as you make them.

**Table 53** Advanced Application > Loop Guard (continued)

LABEL	DESCRIPTION
Active	Select this check box to enable the loop guard feature on this port. The Switch sends probe packets from this port to check if the Switch it is connected to is in loop state. If the Switch that this port is connected is in loop state the Switch will shut down this port. Clear this check box to disable the loop guard feature.
Apply	Click <b>Apply</b> to save your changes to the Switch's run-time memory. The Switch loses these changes if it is turned off or loses power, so use the <b>Save</b> link on the top navigation panel to save your changes to the non-volatile memory when you are done configuring.
Cancel	Click <b>Cancel</b> to begin configuring this screen afresh.

---

# PART IV

# IP Application

---

Static Route (159)

Differentiated Services (163)

DHCP (167)



# Static Route

## 21.1 Static Routing Overview

This chapter shows you how to configure static routes.

The Switch uses IP for communication with management computers, for example using HTTP, telnet, SSH, or SNMP. Use IP static routes to have the Switch respond to remote management stations that are not reachable through the default gateway. The Switch can also use static routes to send data to a server or device that is not reachable through the default gateway, for example when sending SNMP traps or using ping to test IP connectivity.

This figure shows a **Telnet** session coming in from network **N1**. The Switch sends reply traffic to default gateway **R1** which routes it back to the manager's computer. The Switch needs a static route to tell it to use router **R2** to send traffic to an SNMP trap server on network **N2**.

**Figure 83** Static Routing Overview

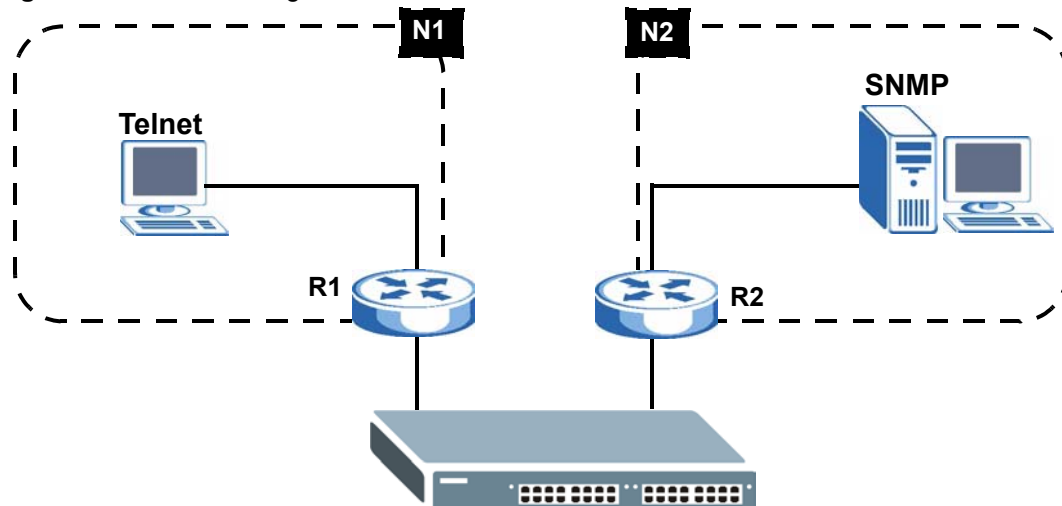

## 21.2 Configuring Static Routing

Click **IP Application > Static Routing** in the navigation panel to display the screen as shown.

**Figure 84** IP Application > Static Routing

Index	Active	Name	Destination Address	Subnet Mask	Gateway Address	Metric	Delete
1	Yes	Example	172.21.1.1	255.255.0.0	192.168.1.2	2	<input type="checkbox"/>

The following table describes the related labels you use to create a static route.

**Table 54** IP Application > Static Routing

LABEL	DESCRIPTION
Active	This field allows you to activate/deactivate this static route.
Name	Enter a descriptive name (up to 10 printable ASCII characters) for identification purposes.
Destination IP Address	This parameter specifies the IP network address of the final destination. Routing is always based on network number. If you need to specify a route to a single host, use a subnet mask of 255.255.255.255 in the subnet mask field to force the network number to be identical to the host ID.
IP Subnet Mask	Enter the subnet mask for this destination.
Gateway IP Address	Enter the IP address of the gateway. The gateway is an immediate neighbor of your Switch that will forward the packet to the destination. The gateway must be a router on the same segment as your Switch.
Metric	The metric represents the “cost” of transmission for routing purposes. IP routing uses hop count as the measurement of cost, with a minimum of 1 for directly connected networks. Enter a number that approximates the cost for this link. The number need not be precise, but it must be between 1 and 15. In practice, 2 or 3 is usually a good number.
Add	Click <b>Add</b> to insert a new static route to the Switch’s run-time memory. The Switch loses these changes if it is turned off or loses power, so use the <b>Save</b> link on the top navigation panel to save your changes to the non-volatile memory when you are done configuring.
Cancel	Click <b>Cancel</b> to begin configuring this screen afresh.
Clear	Click <b>Clear</b> to set the above fields back to the factory defaults.
Index	This field displays the index number of the route. Click a number to edit the static route entry.
Active	This field displays <b>Yes</b> when the static route is activated and <b>NO</b> when it is deactivated.
Name	This field displays the descriptive name for this route. This is for identification purposes only.
Destination Address	This field displays the IP network address of the final destination.
Subnet Mask	This field displays the subnet mask for this destination.



**Table 54** IP Application > Static Routing (continued)

<b>LABEL</b>	<b>DESCRIPTION</b>
Gateway Address	This field displays the IP address of the gateway. The gateway is the immediate neighbor of your Switch that will forward the packet to the destination.
Metric	This field displays the cost of transmission for routing purposes.
Delete	Click <b>Delete</b> to remove the selected entry from the summary table.
Cancel	Click <b>Cancel</b> to clear the <b>Delete</b> check boxes.



# Differentiated Services

This chapter shows you how to configure Differentiated Services (DiffServ) on the Switch.

## 22.1 DiffServ Overview

Quality of Service (QoS) is used to prioritize source-to-destination traffic flows. All packets in the flow are given the same priority. You can use CoS (class of service) to give different priorities to different packet types.

DiffServ is a class of service (CoS) model that marks packets so that they receive specific per-hop treatment at DiffServ-compliant network devices along the route based on the application types and traffic flow. Packets are marked with DiffServ Code Points (DSCPs) indicating the level of service desired. This allows the intermediary DiffServ-compliant network devices to handle the packets differently depending on the code points without the need to negotiate paths or remember state information for every flow. In addition, applications do not have to request a particular service or give advanced notice of where the traffic is going.

### 22.1.1 DSCP and Per-Hop Behavior

DiffServ defines a new DS (Differentiated Services) field to replace the Type of Service (ToS) field in the IP header. The DS field contains a 6-bit DSCP field which can define up to 64 service levels and the remaining 2 bits are defined as currently unused (CU). The following figure illustrates the DS field.

**Figure 85** DiffServ: Differentiated Service Field

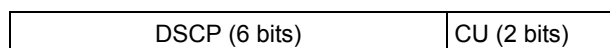

DSCP is backward compatible with the three precedence bits in the ToS octet so that non-DiffServ compliant, ToS-enabled network device will not conflict with the DSCP mapping.

The DSCP value determines the PHB (Per-Hop Behavior), that each packet gets as it is forwarded across the DiffServ network. Based on the marking rule different kinds of traffic can be marked for different priorities of forwarding. Resources can then be allocated according to the DSCP values and the configured policies.

## 22.1.2 DiffServ Network Example

The following figure depicts a DiffServ network consisting of a group of directly connected DiffServ-compliant network devices. The boundary node (**A** in [Figure 86](#)) in a DiffServ network classifies (marks with a DSCP value) the incoming packets into different traffic flows (**Platinum, Gold, Silver, Bronze**) based on the configured marking rules. A network administrator can then apply various traffic policies to the traffic flows. For example, one traffic policy would be to give higher drop precedence to one traffic flow over others. In our example packets in the **Bronze** traffic flow are more likely to be dropped when congestion occurs than the packets in the **Platinum** traffic flow as they move across the DiffServ network.

**Figure 86** DiffServ Network

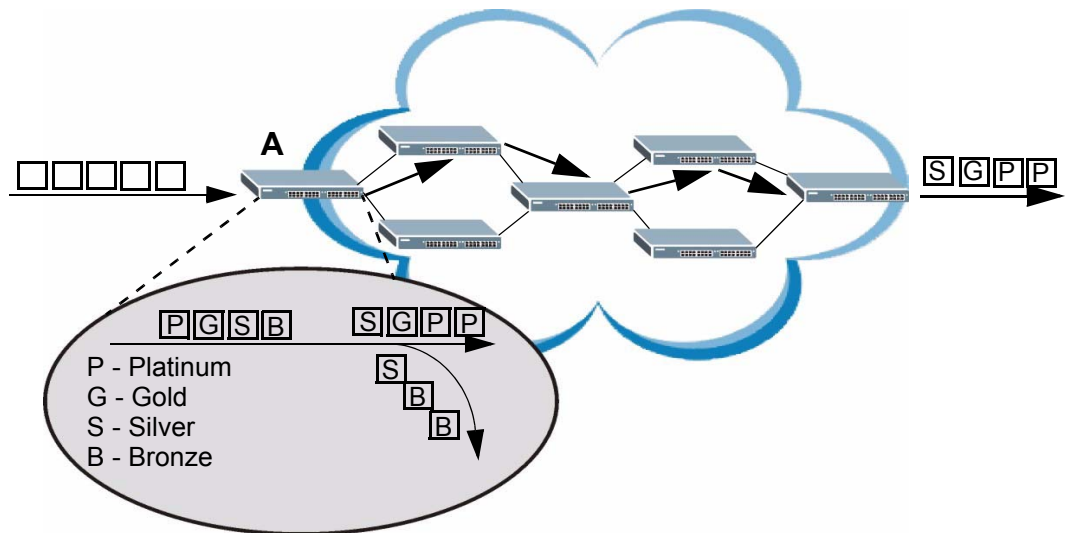

## 22.2 DSCP-to-IEEE 802.1p Priority Settings

You can configure the DSCP to IEEE 802.1p mapping to allow the Switch to prioritize all traffic based on the incoming DSCP value according to the DiffServ to IEEE 802.1p mapping table.

The following table shows the default DSCP-to-IEEE802.1p mapping.

**Table 55** Default DSCP-IEEE 802.1p Mapping

DSCP VALUE	0 – 7	8 – 15	16 – 23	24 – 31	32 – 39	40 – 47	48 – 55	56 – 63
IEEE 802.1p	0	1	2	3	4	5	6	7

## 22.3 Activating DiffServ

Activate DiffServ to apply marking rules or IEEE 802.1p priority mapping on the selected port(s).

Click **IP Application** > **DiffServ** in the navigation panel to display the screen as shown.

Figure 87 IP Application &gt; DiffServ

**DSCP Setting**

Active

**DSCP to 802.1p Mapping**

0	0	1	0	2	0	3	0	4	0	5	0	6	0	7	0
8	1	9	1	10	1	11	1	12	1	13	1	14	1	15	1
16	2	17	2	18	2	19	2	20	2	21	2	22	2	23	2
24	3	25	3	26	3	27	3	28	3	29	3	30	3	31	3
32	4	33	4	34	4	35	4	36	4	37	4	38	4	39	4
40	5	41	5	42	5	43	5	44	5	45	5	46	5	47	5
48	6	49	6	50	6	51	6	52	6	53	6	54	6	55	6
56	7	57	7	58	7	59	7	60	7	61	7	62	7	63	7

Apply Cancel

The following table describes the labels in this screen.

Table 56 IP Application &gt; DiffServ

LABEL	DESCRIPTION
Active	Select this option to enable DiffServ on the Switch.
DSCP to 802.1p Mapping	
0 ... 63	This is the DSCP classification identification number. To set the IEEE 802.1p priority mapping, select the priority level from the drop-down list box.
Apply	Click <b>Apply</b> to save your changes to the Switch's run-time memory. The Switch loses these changes if it is turned off or loses power, so use the <b>Save</b> link on the top navigation panel to save your changes to the non-volatile memory when you are done configuring.
Cancel	Click <b>Cancel</b> to begin configuring this screen afresh.



This chapter shows you how to configure the DHCP feature.

## 23.1 DHCP Overview

DHCP (Dynamic Host Configuration Protocol RFC 2131 and RFC 2132) allows individual computers to obtain TCP/IP configuration at start-up from a server. You can configure the Switch as a DHCP server or a DHCP relay agent. When configured as a server, the Switch provides the TCP/IP configuration for the clients. If you configure the Switch as a relay agent, then the Switch forwards DHCP requests to DHCP server on your network. If you don't configure the Switch as a DHCP server or relay agent then you must have a DHCP server in the broadcast domain of the client computers or else the client computers must be configured manually.

### 23.1.1 DHCP Modes

The Switch can be configured as a DHCP relay agent.

If there is already a DHCP server on your network, then you can configure the Switch as a DHCP relay agent. When the Switch receives a request from a computer on your network, it contacts the DHCP server for the necessary IP information, and then relays the assigned information back to the computer.

### 23.1.2 DHCP Configuration Options

The DHCP configuration on the Switch is divided into **Global** and **VLAN** screens. The screen you should use for configuration depends on the DHCP services you want to offer the DHCP clients on your network. Choose the configuration screen based on the following criteria:

- **Global** - The Switch forwards all DHCP requests to the same DHCP server.
- **VLAN** - The Switch is configured on a VLAN by VLAN basis. The Switch can be configured as a DHCP server for one VLAN and at the same time the Switch can be configured to relay DHCP requests for clients in another VLAN.

## 23.2 DHCP Status

Click **IP Application > DHCP** in the navigation panel. The **DHCP Status** screen displays.

**Figure 88** IP Application > DHCP Status

The following table describes the labels in this screen.

**Table 57** IP Application > DHCP Status

LABEL	DESCRIPTION
Relay Status	This section displays configuration settings related to the Switch's DHCP relay mode.
Relay Mode	This field displays: <ul style="list-style-type: none"> <li>• <b>None</b> - if the Switch is not configured as a DHCP relay agent.</li> <li>• <b>Global</b> - if the Switch is configured as a DHCP relay agent only.</li> <li>• <b>VLAN</b> - followed by a VLAN ID if it is configured as a relay agent for specific VLAN(s).</li> </ul>

## 23.3 DHCP Relay

Configure DHCP relay on the Switch if the DHCP clients and the DHCP server are not in the same broadcast domain. During the initial IP address leasing, the Switch helps to relay network information (such as the IP address and subnet mask) between a DHCP client and a DHCP server. Once the DHCP client obtains an IP address and can connect to the network, network information renewal is done between the DHCP client and the DHCP server without the help of the Switch.

The Switch can be configured as a global DHCP relay. This means that the Switch forwards all DHCP requests from all domains to the same DHCP server. You can also configure the Switch to relay DHCP information based on the VLAN membership of the DHCP clients.

### 23.3.1 DHCP Relay Agent Information

The Switch can add information about the source of client DHCP requests that it relays to a DHCP server by adding **Relay Agent Information**. This helps provide authentication about the source of the requests. The DHCP server can then provide an IP address based on this information. Please refer to RFC 3046 for more details.

The DHCP **Relay Agent Information** feature adds an Agent Information field to the **Option 82** field. The **Option 82** field is in the DHCP headers of client DHCP request frames that the Switch relays to a DHCP server.

**Relay Agent Information** can include the **System Name** of the Switch if you select this option. You can change the **System Name** in **Basic Settings > General Setup**.

The following describes the DHCP relay information that the Switch sends to the DHCP server:

**Table 58** Relay Agent Information

FIELD LABELS	DESCRIPTION
Slot ID	(1 byte) This value is always 0 for stand-alone switches.
Port ID	(1 byte) This is the port that the DHCP client is connected to.



**Table 58** Relay Agent Information

FIELD LABELS	DESCRIPTION
VLAN ID	(2 bytes) This is the VLAN that the port belongs to.
Information	(up to 64 bytes) This optional, read-only field is set according to system name set in <b>Basic Settings &gt; General Setup</b> .

### 23.3.2 Configuring DHCP Global Relay

Configure global DHCP relay in the **DHCP Relay** screen. Click **IP Application > DHCP** in the navigation panel and click the **Global** link to display the screen as shown.

**Figure 89** IP Application > DHCP > Global

The following table describes the labels in this screen.

**Table 59** IP Application > DHCP > Global

LABEL	DESCRIPTION
Active	Select this check box to enable DHCP relay.
Remote DHCP Server 1 .. 3	Enter the IP address of a DHCP server in dotted decimal notation.
Relay Agent Information	Select the <b>Option 82</b> check box to have the Switch add information (slot number, port number and VLAN ID) to client DHCP requests that it relays to a DHCP server.
Information	This read-only field displays the system name you configure in the <b>General Setup</b> screen. Select the check box for the Switch to add the system name to the client DHCP requests that it relays to a DHCP server.
Apply	Click <b>Apply</b> to save your changes to the Switch's run-time memory. The Switch loses these changes if it is turned off or loses power, so use the <b>Save</b> link on the top navigation panel to save your changes to the non-volatile memory when you are done configuring.
Cancel	Click <b>Cancel</b> to begin configuring this screen afresh.

### 23.3.3 Global DHCP Relay Configuration Example

The follow figure shows a network example where the Switch is used to relay DHCP requests for the **VLAN1** and **VLAN2** domains. There is only one DHCP server that services the DHCP clients in both domains.

**Figure 90** Global DHCP Relay Network Example

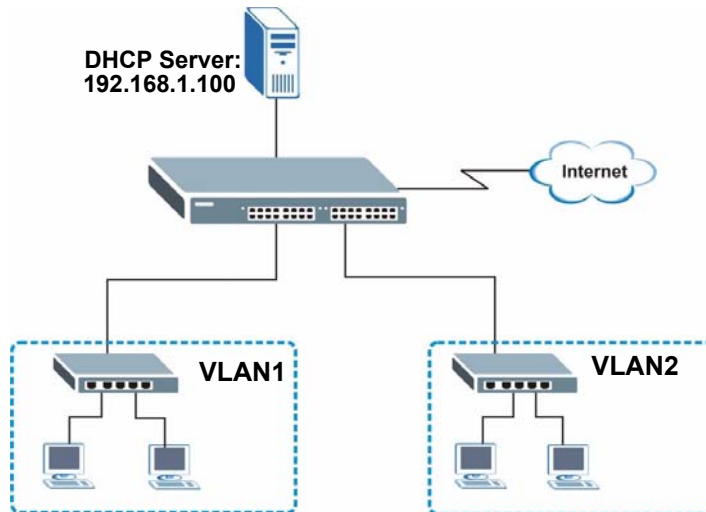

Configure the **DHCP Relay** screen as shown. Make sure you select the **Option 82** check box to set the Switch to send additional information (such as the VLAN ID) together with the DHCP requests to the DHCP server. This allows the DHCP server to assign the appropriate IP address according to the VLAN ID.

**Figure 91** DHCP Relay Configuration Example

DHCP Relay		Status
Active	<input checked="" type="checkbox"/>	
Remote DHCP Server 1	192.168.1.100	
Remote DHCP Server 2	0.0.0.0	
Remote DHCP Server 3	0.0.0.0	
Relay Agent Information	<input checked="" type="checkbox"/> Option 82	
Information	<input type="checkbox"/>	

example

## 23.4 Configuring DHCP VLAN Settings

Use this screen to configure your DHCP settings based on the VLAN domain of the DHCP clients. Click **IP Application > DHCP** in the navigation panel, then click the **VLAN** link In the **DHCP Status** screen that displays.



You must set up a management IP address for each VLAN that you want to configure DHCP settings for on the Switch. See [Section 7.6 on page 69](#) for information on how to do this.

**Figure 92** IP Application > DHCP > VLAN

The following table describes the labels in this screen.

**Table 60** IP Application > DHCP > VLAN

LABEL	DESCRIPTION
VID	Enter the ID number of the VLAN to which these DHCP settings apply.
Remote DHCP Server 1 .. 3	Enter the IP address of a DHCP server in dotted decimal notation.
Relay Agent Information	Select the <b>Option 82</b> check box to have the Switch add information (slot number, port number and VLAN ID) to client DHCP requests that it relays to a DHCP server.
Information	This read-only field displays the system name you configure in the <b>General Setup</b> screen. Select the check box for the Switch to add the system name to the client DHCP requests that it relays to a DHCP server.
Add	Click <b>Add</b> to save your changes to the Switch's run-time memory. The Switch loses these changes if it is turned off or loses power, so use the <b>Save</b> link on the top navigation panel to save your changes to the non-volatile memory when you are done configuring.
Cancel	Click <b>Cancel</b> to begin configuring this screen afresh.
Clear	Click this to clear the fields above.
VID	This field displays the ID number of the VLAN group to which this DHCP settings apply.
Type	This field displays <b>Relay</b> for the DHCP mode.
DHCP Status	This field displays the first remote DHCP server IP address.

**Table 60** IP Application > DHCP > VLAN (continued)

LABEL	DESCRIPTION
Delete	Select the configuration entries you want to remove and click <b>Delete</b> to remove them.
Cancel	Click <b>Cancel</b> to clear the <b>Delete</b> check boxes.

### 23.4.1 Example: DHCP Relay for Two VLANs

The following example displays two VLANs (VIDs 1 and 2) for a campus network. Two DHCP servers are installed to serve each VLAN. The system is set up to forward DHCP requests from the dormitory rooms (VLAN 1) to the DHCP server with an IP address of 192.168.1.100. Requests from the academic buildings (VLAN 2) are sent to the other DHCP server with an IP address of 172.23.10.100.

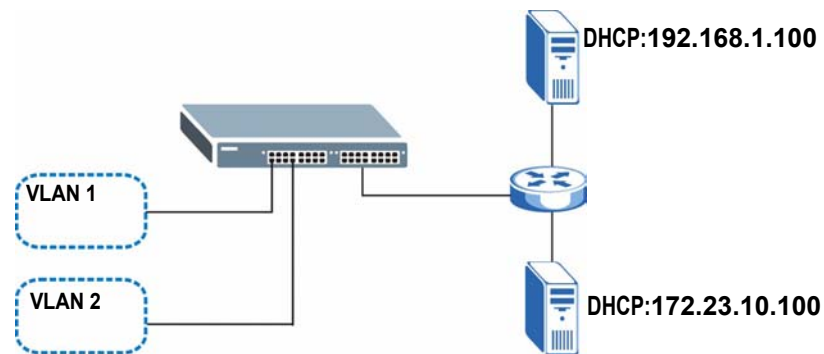
**Figure 93** DHCP Relay for Two VLANs

For the example network, configure the **VLAN Setting** screen as shown.

**Figure 94** DHCP Relay for Two VLANs Configuration Example

The screenshot shows the **VLAN Setting** configuration screen. The screen has a title bar with a status indicator. Below the title bar is a table with the following data:

VID	Remote DHCP Server 1	Remote DHCP Server 2	Remote DHCP Server 3	Relay Agent Information	Information
2	172.23.10.100	0.0.0.0	0.0.0.0	<input type="checkbox"/> Option 82	<input type="checkbox"/>

Below the table are buttons for **Add**, **Cancel**, and **Clear**. At the bottom of the screen, there is a table with the following data:

VID	Type	DHCP Status	Delete
1	Relay	192.168.1.100	<input type="checkbox"/>

At the bottom of the screen, there are buttons for **Delete** and **Cancel**. A red oval containing the word **example** is located at the bottom right of the screen.

---

# PART V

# Management

---

Maintenance (175)  
Access Control (181)  
Diagnostic (199)  
Syslog (201)  
Cluster Management (205)  
MAC Table (211)  
ARP Table (213)  
Configure Clone (215)



# Maintenance

This chapter explains how to configure the maintenance screens that let you maintain the firmware and configuration files.

## 24.1 The Maintenance Screen

Use this screen to manage firmware and your configuration files. Click **Management** > **Maintenance** in the navigation panel to open the following screen.

**Figure 95** Management > Maintenance

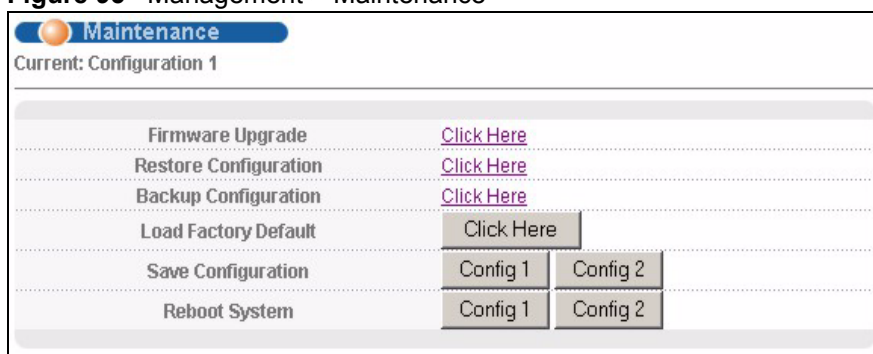

The following table describes the labels in this screen.

**Table 61** Management > Maintenance

LABEL	DESCRIPTION
Current	This field displays which configuration ( <b>Configuration 1</b> or <b>Configuration 2</b> ) is currently operating on the Switch.
Firmware Upgrade	Click <b>Click Here</b> to go to the <b>Firmware Upgrade</b> screen.
Restore Configuration	Click <b>Click Here</b> to go to the <b>Restore Configuration</b> screen.
Backup Configuration	Click <b>Click Here</b> to go to the <b>Backup Configuration</b> screen.
Load Factory Default	Click <b>Click Here</b> to reset the configuration to the factory default settings.

**Table 61** Management > Maintenance (continued)

LABEL	DESCRIPTION
Save Configuration	Click <b>Config 1</b> to save the current configuration settings to <b>Configuration 1</b> on the Switch. Click <b>Config 2</b> to save the current configuration settings to <b>Configuration 2</b> on the Switch.
Reboot System	Click <b>Config 1</b> to reboot the system and load <b>Configuration 1</b> on the Switch. Click <b>Config 2</b> to reboot the system and load <b>Configuration 2</b> on the Switch.  Note: Make sure to click the <b>Save</b> button in any screen to save your settings to the current configuration on the Switch.

## 24.2 Load Factory Default

Follow the steps below to reset the Switch back to the factory defaults.

- 1 In the **Maintenance** screen, click the **Click Here** button next to **Load Factory Default** to clear all Switch configuration information you configured and return to the factory defaults.
- 2 Click **OK** to reset all Switch configurations to the factory defaults.

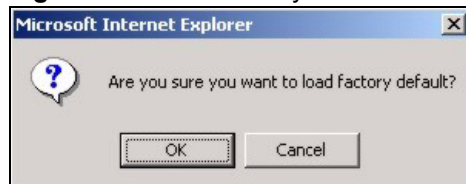
**Figure 96** Load Factory Default: Start

- 3 In the web configurator, click the **Save** button to make the changes take effect. If you want to access the Switch web configurator again, you may need to change the IP address of your computer to be in the same subnet as that of the default Switch IP address (192.168.1.1).

## 24.3 Save Configuration

Click **Config 1** to save the current configuration settings permanently to **Configuration 1** on the Switch.

Click **Config 2** to save the current configuration settings to **Configuration 2** on the Switch.

Alternatively, click **Save** on the top right-hand corner in any screen to save the configuration changes to the current configuration.



Clicking the **Apply** or **Add** button does NOT save the changes permanently. All unsaved changes are erased after you reboot the Switch.



## 24.4 Reboot System

**Reboot System** allows you to restart the Switch without physically turning the power off. It also allows you to load configuration one (**Config 1**) or configuration two (**Config 2**) when you reboot. Follow the steps below to reboot the Switch.

- 1 In the **Maintenance** screen, click the **Config 1** button next to **Reboot System** to reboot and load configuration one. The following screen displays.

**Figure 97** Reboot System: Confirmation



- 2 Click **OK** again and then wait for the Switch to restart. This takes up to two minutes. This does not affect the Switch's configuration.

Click **Config 2** and follow steps 1 to 2 to reboot and load configuration two on the Switch.

## 24.5 Firmware Upgrade

Make sure you have downloaded (and unzipped) the correct model firmware and version to your computer before uploading to the device.



**Be sure to upload the correct model firmware as uploading the wrong model firmware may damage your device.**

From the **Maintenance** screen, display the **Firmware Upgrade** screen as shown next.

**Figure 98** Management > Maintenance > Firmware Upgrade

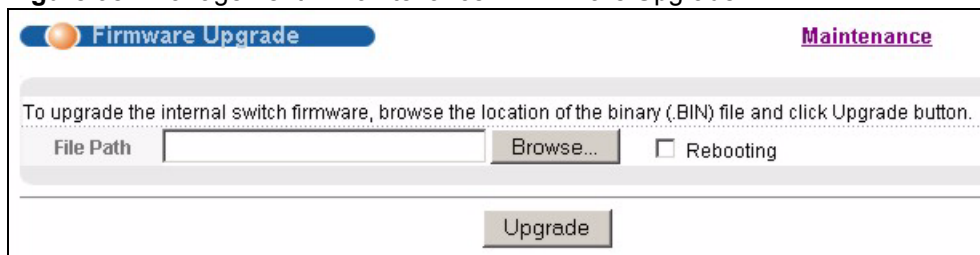

Type the path and file name of the firmware file you wish to upload to the Switch in the **File Path** text box or click **Browse** to locate it. Select the **Rebooting** check box if you want to reboot the Switch and apply the new firmware immediately. (Firmware upgrades are only applied after a reboot). Click **Upgrade** to load the new firmware.

After the firmware upgrade process is complete, see the **System Info** screen to verify your current firmware version number.

## 24.6 Restore a Configuration File

Restore a previously saved configuration from your computer to the Switch using the **Restore Configuration** screen.

**Figure 99** Management > Maintenance > Restore Configuration

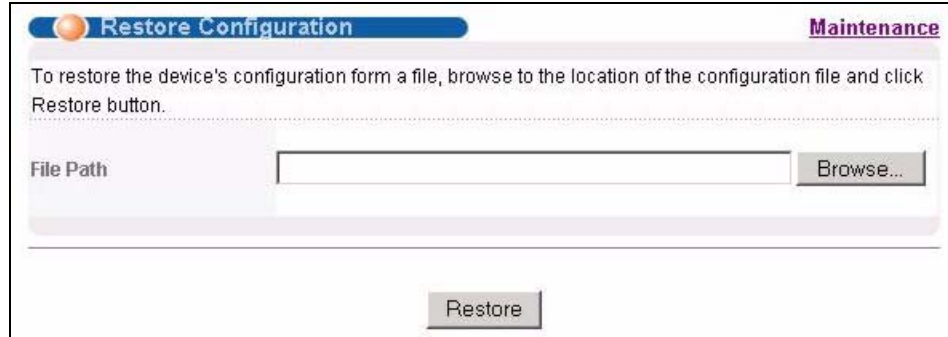

Type the path and file name of the configuration file you wish to restore in the **File Path** text box or click **Browse** to locate it. After you have specified the file, click **Restore**. "config" is the name of the configuration file on the Switch, so your backup configuration file is automatically renamed when you restore using this screen.

## 24.7 Backup a Configuration File

Backing up your Switch configurations allows you to create various “snapshots” of your device from which you may restore at a later date.

Back up your current Switch configuration to a computer using the **Backup Configuration** screen.

**Figure 100** Management > Maintenance > Backup Configuration

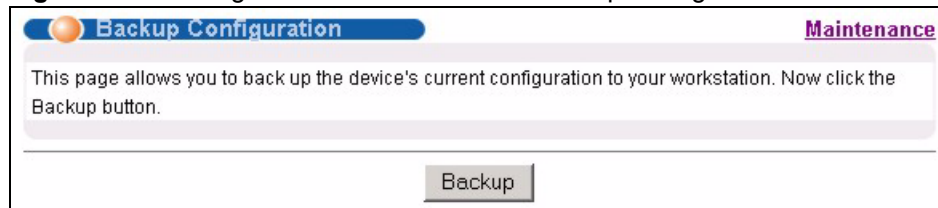

Follow the steps below to back up the current Switch configuration to your computer in this screen.

- 1 Click **Backup**.
- 2 Click **Save** to display the **Save As** screen.
- 3 Choose a location to save the file on your computer from the **Save in** drop-down list box and type a descriptive name for it in the **File name** list box. Click **Save** to save the configuration file to your computer.

## 24.8 FTP Command Line

This section shows some examples of uploading to or downloading files from the Switch using FTP commands. First, understand the filename conventions.

### 24.8.1 Filename Conventions

The configuration file (also known as the romfile or ROM) contains the factory default settings in the screens such as password, Switch setup, IP Setup, and so on. Once you have customized the Switch's settings, they can be saved back to your computer under a filename of your choosing.

ZyNOS (ZyXEL Network Operating System, sometimes referred to as the "ras" file) is the system firmware and has a "bin" filename extension.

**Table 62** Filename Conventions

FILE TYPE	INTERNAL NAME	EXTERNAL NAME	DESCRIPTION
Configuration File	config	.cfg	This is the configuration (config) filename on the Switch. Uploading the config file replaces the specified configuration file system, including your Switch configurations, system-related data (including the default password), the error log and the trace log.
Firmware	ras	*.bin	This is the generic name for the ZyNOS firmware on the Switch.

#### 24.8.1.1 Example FTP Commands

```
ftp> put firmware.bin ras
```

This is a sample FTP session showing the transfer of the computer file "firmware.bin" to the Switch.

```
ftp> get config config.cfg
```

This is a sample FTP session saving the current configuration to a file called "config.cfg" on your computer.

If your (T)FTP client does not allow you to have a destination filename different than the source, you will need to rename them as the Switch only recognizes "config" and "ras". Be sure you keep unaltered copies of both files for later use.



**Be sure to upload the correct model firmware as uploading the wrong model firmware may damage your device.**

### 24.8.2 FTP Command Line Procedure

- 1 Launch the FTP client on your computer.
- 2 Enter `open`, followed by a space and the IP address of your Switch.
- 3 Press [ENTER] when prompted for a username.
- 4 Enter your password as requested (the default is "1234").

- 5 Enter `bin` to set transfer mode to binary.
- 6 Use `put` to transfer files from the computer to the Switch, for example, `put firmware.bin ras` transfers the firmware on your computer (`firmware.bin`) to the Switch and renames it to “`ras`”. Similarly, `put config.cfg config` transfers the configuration file on your computer (`config.cfg`) to the Switch and renames it to “`config`”. Likewise `get config config.cfg` transfers the configuration file on the Switch to your computer and renames it to “`config.cfg`”. See [Table 62 on page 179](#) for more information on filename conventions.
- 7 Enter `quit` to exit the ftp prompt.

### 24.8.3 GUI-based FTP Clients

The following table describes some of the commands that you may see in GUI-based FTP clients.

**Table 63** General Commands for GUI-based FTP Clients

COMMAND	DESCRIPTION
Host Address	Enter the address of the host server.
Login Type	Anonymous. This is when a user I.D. and password is automatically supplied to the server for anonymous access. Anonymous logins will work only if your ISP or service administrator has enabled this option. Normal. The server requires a unique User ID and Password to login.
Transfer Type	Transfer files in either ASCII (plain text format) or in binary mode. Configuration and firmware files should be transferred in binary mode.
Initial Remote Directory	Specify the default remote directory (path).
Initial Local Directory	Specify the default local directory (path).

### 24.8.4 FTP Restrictions

FTP will not work when:

- FTP service is disabled in the **Service Access Control** screen.
- The IP address(es) in the **Remote Management** screen does not match the client IP address. If it does not match, the Switch will disallow the FTP session.

# Access Control

This chapter describes how to control access to the Switch.

## 25.1 Access Control Overview

A console port and FTP are allowed one session each, Telnet and SSH share nine sessions, up to five Web sessions (five different usernames and passwords) and/or limitless SNMP access control sessions are allowed.

**Table 64** Access Control Overview

Console Port	SSH	Telnet	FTP	Web	SNMP
One session	Share up to nine sessions		One session	Up to five accounts	No limit

A console port access control session and Telnet access control session cannot coexist when multi-login is disabled. See the CLI reference guide for more information on disabling multi-login.

## 25.2 The Access Control Main Screen

Click **Management > Access Control** in the navigation panel to display the main screen as shown.

**Figure 101** Management > Access Control



## 25.3 About SNMP

Simple Network Management Protocol (SNMP) is an application layer protocol used to manage and monitor TCP/IP-based devices. SNMP is used to exchange management information between the network management system (NMS) and a network element (NE). A manager station can manage and monitor the Switch through the network via SNMP version one (SNMPv1), SNMP version 2c or SNMP version 3. The next figure illustrates an SNMP management operation. SNMP is only available if TCP/IP is configured.

**Figure 102** SNMP Management Model

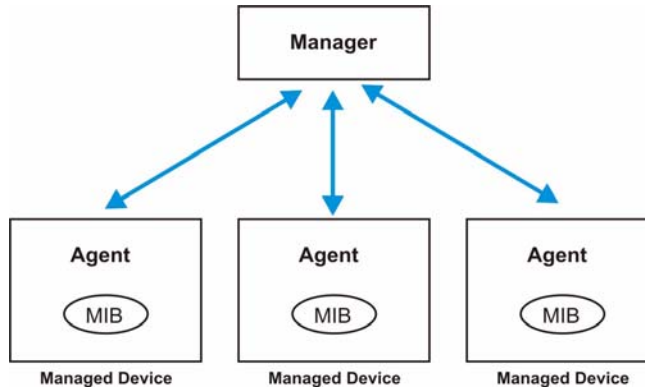

An SNMP managed network consists of two main components: agents and a manager.

An agent is a management software module that resides in a managed Switch (the Switch). An agent translates the local management information from the managed Switch into a form compatible with SNMP. The manager is the console through which network administrators perform network management functions. It executes applications that control and monitor managed devices.

The managed devices contain object variables/managed objects that define each piece of information to be collected about a Switch. Examples of variables include number of packets received, node port status and so on. A Management Information Base (MIB) is a collection of managed objects. SNMP allows a manager and agents to communicate for the purpose of accessing these objects.

SNMP itself is a simple request/response protocol based on the manager/agent model. The manager issues a request and the agent returns responses using the following protocol operations:

**Table 65** SNMP Commands

COMMAND	DESCRIPTION
Get	Allows the manager to retrieve an object variable from the agent.
GetNext	Allows the manager to retrieve the next object variable from a table or list within an agent. In SNMPv1, when a manager wants to retrieve all elements of a table from an agent, it initiates a Get operation, followed by a series of GetNext operations.
Set	Allows the manager to set values for object variables within an agent.
Trap	Used by the agent to inform the manager of some events.

### 25.3.1 SNMP v3 and Security

SNMP v3 enhances security for SNMP management. SNMP managers can be required to authenticate with agents before conducting SNMP management sessions.

Security can be further enhanced by encrypting the SNMP messages sent from the managers. Encryption protects the contents of the SNMP messages. When the contents of the SNMP messages are encrypted, only the intended recipients can read them.

### 25.3.2 Supported MIBs

MIBs let administrators collect statistics and monitor status and performance.

The Switch supports the following MIBs:

- SNMP MIB II (RFC 1213)
- RFC 1157 SNMP v1
- RFC 1493 Bridge MIBs
- RFC 1643 Ethernet MIBs
- RFC 1155 SMI
- RFC 2674 SNMPv2, SNMPv2c
- RFC 1757 RMON
- SNMPv2, SNMPv2c or later version, compliant with RFC 2011 SNMPv2 MIB for IP, RFC 2012 SNMPv2 MIB for TCP, RFC 2013 SNMPv2 MIB for UDP

### 25.3.3 SNMP Traps

The Switch sends traps to an SNMP manager when an event occurs. The following tables outline the SNMP traps by category.

An OID (Object ID) that begins with “1.3.6.1.4.1.890.1.5.8.” is defined in private MIBs. Otherwise, it is a standard MIB OID.

**Table 66** SNMP System Traps

OPTION	OBJECT LABEL	OBJECT ID	DESCRIPTION
coldstart	coldStart	1.3.6.1.6.3.1.1.5.1	This trap is sent when the Switch is turned on.
warmstart	warmStart	1.3.6.1.6.3.1.1.5.2	This trap is sent when the Switch restarts.
fanspeed	FanSpeedEventOn	1.3.6.1.4.1.890.1.5.8.15.28.2.1	This trap is sent when the fan speed goes above or below the normal operating range.
	FanSpeedEventClear	1.3.6.1.4.1.890.1.5.8.15.28.2.2	This trap is sent when the fan speed returns to the normal operating range.
temperature	TemperatureEventOn	1.3.6.1.4.1.890.1.5.8.15.28.2.1	This trap is sent when the temperature goes above or below the normal operating range.
	TemperatureEventClear	1.3.6.1.4.1.890.1.5.8.15.28.2.2	This trap is sent when the temperature returns to the normal operating range.

**Table 66** SNMP System Traps (continued)

OPTION	OBJECT LABEL	OBJECT ID	DESCRIPTION
voltage	VoltageEventOn	1.3.6.1.4.1.890.1.5.8.15.28.2.1	This trap is sent when the voltage goes above or below the normal operating range.
	VoltageEventClear	1.3.6.1.4.1.890.1.5.8.15.28.2.2	This trap is sent when the voltage returns to the normal operating range.
reset	UncontrolledResetEventOn	1.3.6.1.4.1.890.1.5.8.15.28.2.1	This trap is sent when the Switch automatically resets.
	ControlledResetEventOn	1.3.6.1.4.1.890.1.5.8.15.28.2.1	This trap is sent when the Switch resets by an administrator through a management interface.
	RebootEvent	1.3.6.1.4.1.890.1.5.1.1.2	This trap is sent when the Switch reboots by an administrator through a management interface.
timesync	RTCNotUpdatedEventOn	1.3.6.1.4.1.890.1.5.8.15.28.2.1	This trap is sent when the Switch fails to get the time and date from a time server.
	RTCNotUpdatedEventClear	1.3.6.1.4.1.890.1.5.8.15.28.2.2	This trap is sent when the Switch gets the time and date from a time server.
intrusionlock	IntrusionLockEventOn	1.3.6.1.4.1.890.1.5.8.15.28.2.1	This trap is sent when intrusion lock occurs on a port.
loopguard	LoopguardEventOn	1.3.6.1.4.1.890.1.5.8.15.28.2.1	This trap is sent when loopguard shuts down a port.

**Table 67** SNMP Interface Traps

OPTION	OBJECT LABEL	OBJECT ID	DESCRIPTION
linkup	linkUp	1.3.6.1.6.3.1.1.5.4	This trap is sent when the Ethernet link is up.
	LinkDownEventClear	1.3.6.1.4.1.890.1.5.8.15.28.2.2	This trap is sent when the Ethernet link is up.
linkdown	linkDown	1.3.6.1.6.3.1.1.5.3	This trap is sent when the Ethernet link is down.
	LinkDownEventOn	1.3.6.1.4.1.890.1.5.8.15.28.2.1	This trap is sent when the Ethernet link is down.
autonegotiation	AutonegotiationFailedEventOn	1.3.6.1.4.1.890.1.5.8.15.28.2.1	This trap is sent when an Ethernet interface fails to auto-negotiate with the peer Ethernet interface.
	AutonegotiationFailedEventClear	1.3.6.1.4.1.890.1.5.8.15.28.2.2	This trap is sent when an Ethernet interface auto-negotiates with the peer Ethernet interface.



**Table 68** AAA Traps

OPTION	OBJECT LABEL	OBJECT ID	DESCRIPTION
authentication	authenticationFailure	1.3.6.1.6.3.1.1.5.5	This trap is sent when authentication fails due to incorrect user name and/or password.
	AuthenticationFailureEventOn	1.3.6.1.4.1.890.1.5.8.15.28.2.1	This trap is sent when authentication fails due to incorrect user name and/or password.
	RADIUSNotReachableEventOn	1.3.6.1.4.1.890.1.5.8.15.28.2.1	This trap is sent when there is no response message from the RADIUS server.
	RADIUSNotReachableEventClear	1.3.6.1.4.1.890.1.5.8.15.28.2.2	This trap is sent when the RADIUS server can be reached.
accounting	RADIUSAcctNotReachableEventOn	1.3.6.1.4.1.890.1.5.8.15.28.2.1	This trap is sent when there is no response message from the RADIUS accounting server.
	RADIUSAcctNotReachableEventClear	1.3.6.1.4.1.890.1.5.8.15.28.2.2	This trap is sent when the RADIUS accounting server can be reached.

**Table 69** SNMP IP Traps

OPTION	OBJECT LABEL	OBJECT ID	DESCRIPTION
ping	pingProbeFailed	1.3.6.1.2.1.80.0.1	This trap is sent when a single ping probe fails.
	pingTestFailed	1.3.6.1.2.1.80.0.2	This trap is sent when a ping test (consisting of a series of ping probes) fails.
	pingTestCompleted	1.3.6.1.2.1.80.0.3	This trap is sent when a ping test is completed.
traceroute	traceRouteTestFailed	1.3.6.1.2.1.81.0.2	This trap is sent when a traceroute test fails.
	traceRouteTestCompleted	1.3.6.1.2.1.81.0.3	This trap is sent when a traceroute test is completed.

**Table 70** SNMP Switch Traps

OPTION	OBJECT LABEL	OBJECT ID	DESCRIPTION
stp	STPNewRoot	1.3.6.1.2.1.17.0.1	This trap is sent when the STP root switch changes.
	MSTPNewRoot	1.3.6.1.4.1.890.1.5.8.15.107.7.0.1	This trap is sent when the MSTP root switch changes.
	STPTopologyChange	1.3.6.1.2.1.17.0.2	This trap is sent when the STP topology changes.
	MSTPTopologyChange	1.3.6.1.4.1.890.1.5.8.15.107.7.0.2	This trap is sent when the MSTP root switch changes.

**Table 70** SNMP Switch Traps (continued)

OPTION	OBJECT LABEL	OBJECT ID	DESCRIPTION
mactable	MacTableFullEventOn	1.3.6.1.4.1.890.1.5.8.15.28.2.1	This trap is sent when more than 99% of the MAC table is used.
	MacTableFullEventClear	1.3.6.1.4.1.890.1.5.8.15.28.2.2	This trap is sent when less than 95% of the MAC table is used.
rmon	RmonRisingAlarm	1.3.6.1.4.1.890.1.5.1.1.16.0.1	This trap is sent when a variable goes over the RMON "rising" threshold.
	RmonFallingAlarm	1.3.6.1.4.1.890.1.5.1.1.16.0.2	This trap is sent when the variable falls below the RMON "falling" threshold.

### 25.3.4 Configuring SNMP

From the **Access Control** screen, display the **SNMP** screen. You can click **Access Control** to go back to the **Access Control** screen.

**Figure 103** Management > Access Control > SNMP

The screenshot shows the SNMP configuration interface. At the top, there are tabs for 'SNMP', 'Access Control', and 'Trap Group'. The 'SNMP' tab is active, and the 'General Setting' section is expanded. Below this, there are three rows of configuration fields: 'Version' (set to v2c), 'Get Community' (set to public), 'Set Community' (set to public), and 'Trap Community' (set to public). The 'Trap Destination' section is also expanded, showing a table with four columns: 'Version', 'IP', 'Port', and 'Username'. Each row in the table has a 'v2c' dropdown, an IP address of '0.0.0.0', and a port of '162'. The 'User Information' section is also expanded, showing a table with five columns: 'Index', 'Username', 'Security Level', 'Authentication', and 'Privacy'. The first row has an index of '1', a username of 'admin', a security level of 'noauth', an authentication method of 'MD5', and a privacy method of 'DES'. At the bottom of the screen, there are 'Apply' and 'Cancel' buttons.

The following table describes the labels in this screen.

**Table 71** Management > Access Control > SNMP

LABEL	DESCRIPTION
General Setting	Use this section to specify the SNMP version and community (password) values.
Version	Select the SNMP version for the Switch. The SNMP version on the Switch must match the version on the SNMP manager. Choose SNMP version 2c ( <b>v2c</b> ), SNMP version 3 ( <b>v3</b> ) or both ( <b>v3v2c</b> ).  Note: SNMP version 2c is backwards compatible with SNMP version 1.
Get Community	Enter the <b>Get Community</b> string, which is the password for the incoming Get- and GetNext- requests from the management station. The <b>Get Community</b> string is only used by SNMP managers using SNMP version 2c or lower.
Set Community	Enter the <b>Set Community</b> , which is the password for incoming Set- requests from the management station. The <b>Set Community</b> string is only used by SNMP managers using SNMP version 2c or lower.
Trap Community	Enter the <b>Trap Community</b> string, which is the password sent with each trap to the SNMP manager. The <b>Trap Community</b> string is only used by SNMP managers using SNMP version 2c or lower.
Trap Destination	Use this section to configure where to send SNMP traps from the Switch.
Version	Specify the version of the SNMP trap messages.
IP	Enter the IP addresses of up to four managers to send your SNMP traps to.
Port	Enter the port number upon which the manager listens for SNMP traps.
Username	Enter the username to be sent to the SNMP manager along with the SNMP v3 trap.  Note: This username must match an existing account on the Switch (configured in <b>Management &gt; Access Control &gt; Logins</b> screen).
User Information	Use this section to configure users for authentication with managers using SNMP v3.  Note: Use the username and password of the login accounts you specify in this section to create accounts on the SNMP v3 manager.
Index	This is a read-only number identifying a login account on the Switch.
Username	This field displays the username of a login account on the Switch.

**Table 71** Management > Access Control > SNMP (continued)

LABEL	DESCRIPTION
Security Level	<p>Select whether you want to implement authentication and/or encryption for SNMP communication from this user. Choose:</p> <ul style="list-style-type: none"> <li>• <b>noauth</b> -to use the username as the password string to send to the SNMP manager. This is equivalent to the Get, Set and Trap Community in SNMP v2c. This is the lowest security level.</li> <li>• <b>auth</b> - to implement an authentication algorithm for SNMP messages sent by this user.</li> <li>• <b>priv</b> - to implement authentication and encryption for SNMP messages sent by this user. This is the highest security level.</li> </ul> <p>Note: The settings on the SNMP manager must be set at the same security level or higher than the security level settings on the Switch.</p>
Authentication	Select an authentication algorithm. MD5 (Message Digest 5) and SHA (Secure Hash Algorithm) are hash algorithms used to authenticate SNMP data. SHA authentication is generally considered stronger than MD5, but is slower.
Privacy	<p>Specify the encryption method for SNMP communication from this user. You can choose one of the following:</p> <ul style="list-style-type: none"> <li>• <b>DES</b> - Data Encryption Standard is a widely used (but breakable) method of data encryption. It applies a 56-bit key to each 64-bit block of data.</li> <li>• <b>AES</b> - Advanced Encryption Standard is another method for data encryption that also uses a secret key. AES applies a 128-bit key to 128-bit blocks of data.</li> </ul>
Apply	Click <b>Apply</b> to save your changes to the Switch's run-time memory. The Switch loses these changes if it is turned off or loses power, so use the <b>Save</b> link on the top navigation panel to save your changes to the non-volatile memory when you are done configuring.
Cancel	Click <b>Cancel</b> to begin configuring this screen afresh.

### 25.3.5 Configuring SNMP Trap Group

From the **SNMP** screen, click **Trap Group** to view the screen as shown. Use the **Trap Group** screen to specify the types of SNMP traps that should be sent to each SNMP manager.

**Figure 104** Management > Access Control > SNMP > Trap Group

The screenshot shows the 'Trap Group' configuration screen. At the top, there is a 'Trap Destination IP' dropdown menu. Below it is a table with two columns: 'Type' and 'Options'. The 'Type' column lists 'System', 'Interface', 'AAA', 'IP', and 'Switch', each with a checkbox and an asterisk. The 'Options' column lists various trap types with checkboxes. The 'fanspeed' and 'reset' options are checked. At the bottom of the screen, there are 'Apply' and 'Cancel' buttons.

Type	Options
System <input type="checkbox"/> *	<input type="checkbox"/> coldstart <input type="checkbox"/> warmstart <input checked="" type="checkbox"/> fanspeed
	<input type="checkbox"/> temperature <input type="checkbox"/> voltage <input checked="" type="checkbox"/> reset
	<input type="checkbox"/> timesync <input type="checkbox"/> intrusionlock <input type="checkbox"/> loopguard
Interface <input type="checkbox"/> *	<input type="checkbox"/> linkup <input type="checkbox"/> linkdown <input type="checkbox"/> autonegotiation
AAA <input type="checkbox"/> *	<input type="checkbox"/> authentication <input type="checkbox"/> accounting
IP <input type="checkbox"/> *	<input type="checkbox"/> ping <input type="checkbox"/> traceroute
Switch <input type="checkbox"/> *	<input type="checkbox"/> stp <input type="checkbox"/> mactable <input type="checkbox"/> rmon

The following table describes the labels in this screen.

**Table 72** Management > Access Control > SNMP > Trap Group

LABEL	DESCRIPTION
Trap Destination IP	Select one of your configured trap destination IP addresses. These are the IP addresses of the SNMP managers. You must first configure a trap destination IP address in the <b>SNMP Setting</b> screen. Use the rest of the screen to select which traps the Switch sends to that SNMP manager.
Type	Select the categories of SNMP traps that the Switch is to send to the SNMP manager.
Options	Select the individual SNMP traps that the Switch is to send to the SNMP station. See <a href="#">Section 25.3.3 on page 183</a> for individual trap descriptions. The traps are grouped by category. Selecting a category automatically selects all of the category's traps. Clear the check boxes for individual traps that you do not want the Switch to send to the SNMP station. Clearing a category's check box automatically clears all of the category's trap check boxes (the Switch only sends traps from selected categories).
Apply	Click <b>Apply</b> to save your changes to the Switch's run-time memory. The Switch loses these changes if it is turned off or loses power, so use the <b>Save</b> link on the top navigation panel to save your changes to the non-volatile memory when you are done configuring.
Cancel	Click <b>Cancel</b> to begin configuring this screen afresh.

## 25.3.6 Setting Up Login Accounts

Up to five people (one administrator and four non-administrators) may access the Switch via web configurator at any one time.

- An administrator is someone who can both view and configure Switch changes. The username for the Administrator is always **admin**. The default administrator password is **1234**.



It is highly recommended that you change the default administrator password (**1234**).

- A non-administrator (username is something other than **admin**) is someone who can view but not configure Switch settings.

Click **Management > Access Control > Logins** to view the screen as shown.

**Figure 105** Management > Access Control > Logins

**Logins** [Access Control](#)

**Administrator**

Old Password

New Password

Retype to confirm

**Please record your new password whenever you change it. The system will lock you out if you have forgotten your password.**

**Edit Logins**

Login	User Name	Password	Retype to confirm
1	<input type="text"/>	<input type="text"/>	<input type="text"/>
2	<input type="text"/>	<input type="text"/>	<input type="text"/>
3	<input type="text"/>	<input type="text"/>	<input type="text"/>
4	<input type="text"/>	<input type="text"/>	<input type="text"/>

The following table describes the labels in this screen.

**Table 73** Management > Access Control > Logins

LABEL	DESCRIPTION
Administrator	This is the default administrator account with the “admin” user name. You cannot change the default administrator user name. Only the administrator has read/write access.
Old Password	Type the existing system password ( <b>1234</b> is the default password when shipped).
New Password	Enter your new system password.
Retype to confirm	Retype your new system password for confirmation
Edit Logins	You may configure passwords for up to four users. These users have read-only access. You can give users higher privileges via the CLI. For more information on assigning privileges see the CLI reference guide.
User Name	Set a user name (up to 32 ASCII characters long).
Password	Enter your new system password.
Retype to confirm	Retype your new system password for confirmation
Apply	Click <b>Apply</b> to save your changes to the Switch’s run-time memory. The Switch loses these changes if it is turned off or loses power, so use the <b>Save</b> link on the top navigation panel to save your changes to the non-volatile memory when you are done configuring.
Cancel	Click <b>Cancel</b> to begin configuring this screen afresh.

## 25.4 SSH Overview

Unlike Telnet or FTP, which transmit data in clear text, SSH (Secure Shell) is a secure communication protocol that combines authentication and data encryption to provide secure encrypted communication between two hosts over an unsecured network.

**Figure 106** SSH Communication Example



## 25.5 How SSH works

The following table summarizes how a secure connection is established between two remote hosts.

**Figure 107** How SSH Works

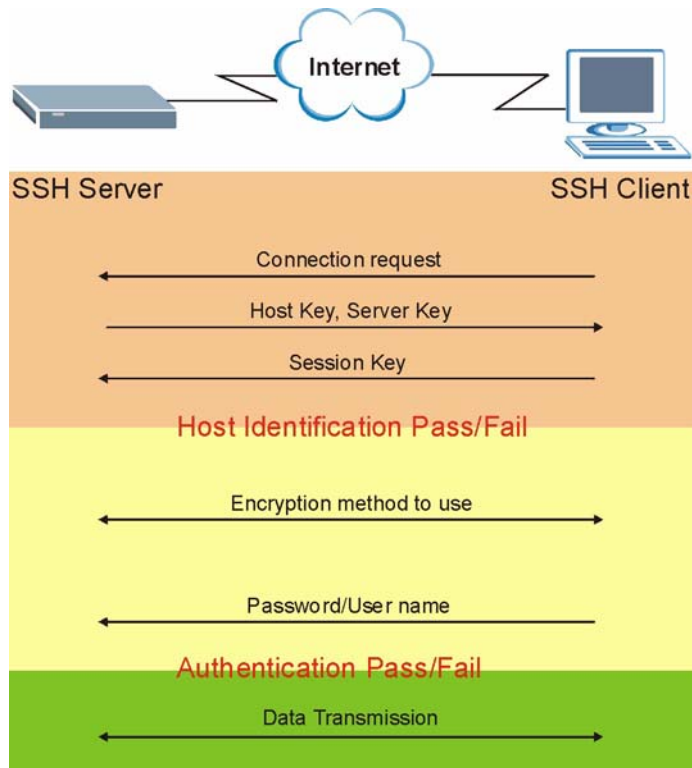

### 1 Host Identification

The SSH client sends a connection request to the SSH server. The server identifies itself with a host key. The client encrypts a randomly generated session key with the host key and server key and sends the result back to the server.

The client automatically saves any new server public keys. In subsequent connections, the server public key is checked against the saved version on the client computer.

**2 Encryption Method**

Once the identification is verified, both the client and server must agree on the type of encryption method to use.

**3 Authentication and Data Transmission**

After the identification is verified and data encryption activated, a secure tunnel is established between the client and the server. The client then sends its authentication information (user name and password) to the server to log in to the server.

## 25.6 SSH Implementation on the Switch

Your Switch supports SSH version 2 using RSA authentication and three encryption methods (DES, 3DES and Blowfish). The SSH server is implemented on the Switch for remote management and file transfer on port 22. Only one SSH connection is allowed at a time.

### 25.6.1 Requirements for Using SSH

You must install an SSH client program on a client computer (Windows or Linux operating system) that is used to connect to the Switch over SSH.

## 25.7 Introduction to HTTPS

HTTPS (HyperText Transfer Protocol over Secure Socket Layer, or HTTP over SSL) is a web protocol that encrypts and decrypts web pages. Secure Socket Layer (SSL) is an application-level protocol that enables secure transactions of data by ensuring confidentiality (an unauthorized party cannot read the transferred data), authentication (one party can identify the other party) and data integrity (you know if data has been changed).

It relies upon certificates, public keys, and private keys.

HTTPS on the Switch is used so that you may securely access the Switch using the web configurator. The SSL protocol specifies that the SSL server (the Switch) must always authenticate itself to the SSL client (the computer which requests the HTTPS connection with the Switch), whereas the SSL client only should authenticate itself when the SSL server requires it to do so. Authenticating client certificates is optional and if selected means the SSL-client must send the Switch a certificate. You must apply for a certificate for the browser from a Certificate Authority (CA) that is a trusted CA on the Switch.

Please refer to the following figure.

- 1** HTTPS connection requests from an SSL-aware web browser go to port 443 (by default) on the Switch's WS (web server).
- 2** HTTP connection requests from a web browser go to port 80 (by default) on the Switch's WS (web server).

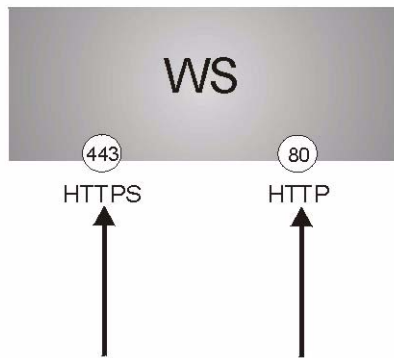

**Figure 108** HTTPS Implementation

If you disable **HTTP** in the **Service Access Control** screen, then the Switch blocks all HTTP connection attempts.

## 25.8 HTTPS Example

If you haven't changed the default HTTPS port on the Switch, then in your browser enter "https://Switch IP Address/" as the web site address where "Switch IP Address" is the IP address or domain name of the Switch you wish to access.

### 25.8.1 Internet Explorer Warning Messages

When you attempt to access the Switch HTTPS server, a Windows dialog box pops up asking if you trust the server certificate. Click **View Certificate** if you want to verify that the certificate is from the Switch.

You see the following **Security Alert** screen in Internet Explorer. Select **Yes** to proceed to the web configurator login screen; if you select **No**, then web configurator access is blocked.

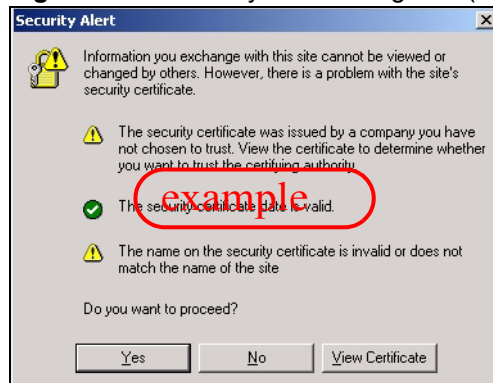
**Figure 109** Security Alert Dialog Box (Internet Explorer)

## 25.8.2 Netscape Navigator Warning Messages

When you attempt to access the Switch HTTPS server, a **Website Certified by an Unknown Authority** screen pops up asking if you trust the server certificate. Click **Examine Certificate** if you want to verify that the certificate is from the Switch.

If **Accept this certificate temporarily for this session** is selected, then click **OK** to continue in Netscape.

Select **Accept this certificate permanently** to import the Switch's certificate into the SSL client.

**Figure 110** Security Certificate 1 (Netscape)

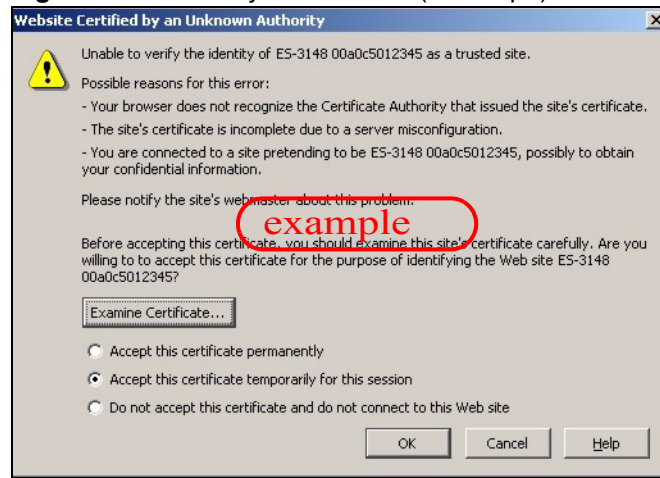

**Figure 111** Security Certificate 2 (Netscape)



## 25.8.3 The Main Screen

After you accept the certificate and enter the login username and password, the Switch main screen appears. The lock displayed in the bottom right of the browser status bar denotes a secure connection.

Figure 112 Example: Lock Denoting a Secure Connection

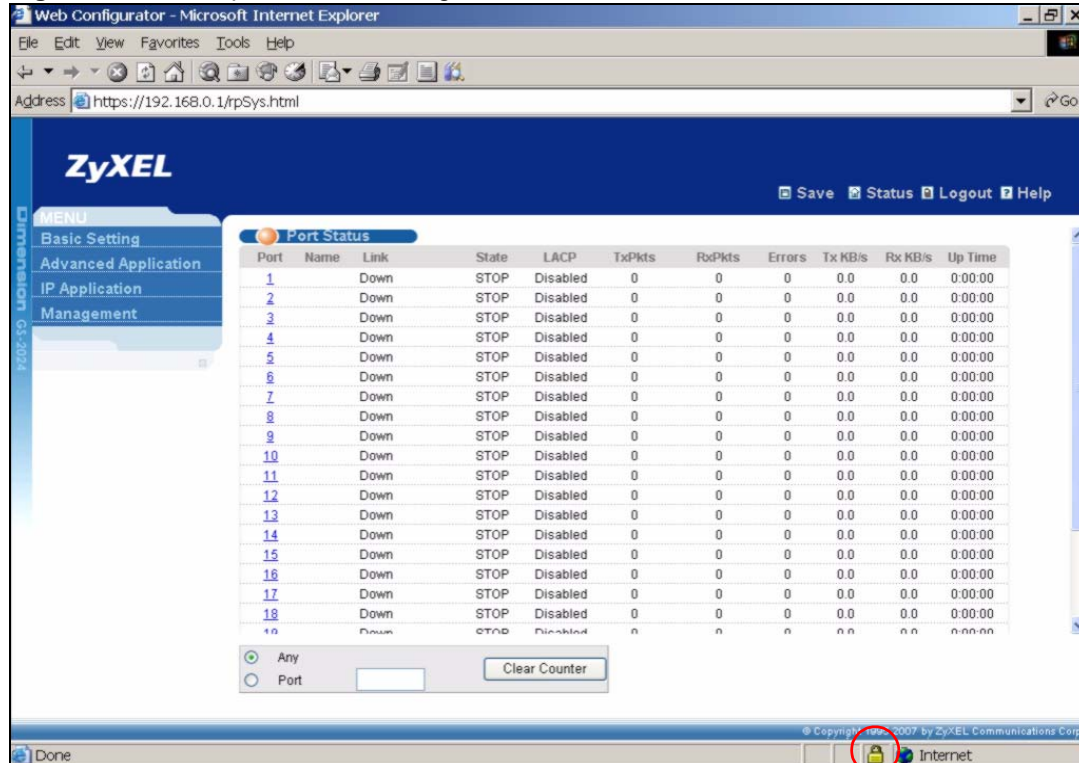

## 25.9 Service Port Access Control

Service Access Control allows you to decide what services you may use to access the Switch. You may also change the default service port and configure “trusted computer(s)” for each service in the **Remote Management** screen (discussed later). Click **Access Control** to go back to the main **Access Control** screen.

Figure 113 Management &gt; Access Control &gt; Service Access Control

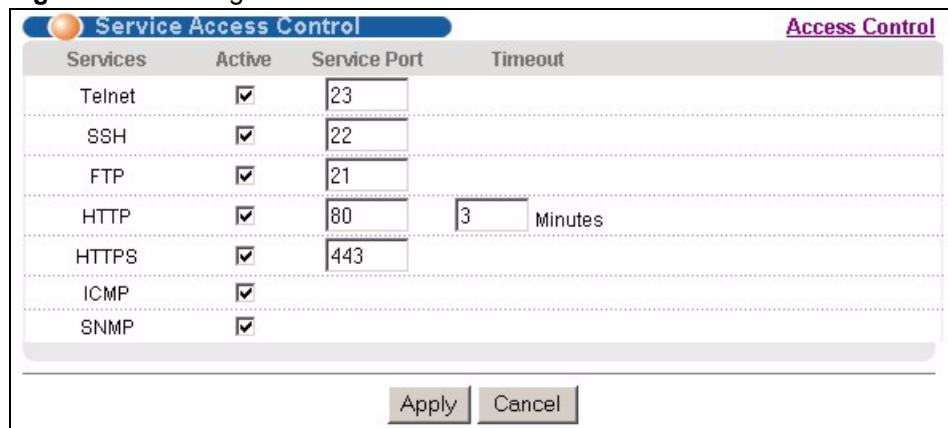

The following table describes the fields in this screen.

**Table 74** Management > Access Control > Service Access Control

LABEL	DESCRIPTION
Services	Services you may use to access the Switch are listed here.
Active	Select this option for the corresponding services that you want to allow to access the Switch.
Service Port	For Telnet, SSH, FTP, HTTP or HTTPS services, you may change the default service port by typing the new port number in the <b>Server Port</b> field. If you change the default port number then you will have to let people (who wish to use the service) know the new port number for that service.
Timeout	Type how many minutes a management session (via the web configurator) can be left idle before the session times out. After it times out you have to log in with your password again. Very long idle timeouts may have security risks.
Apply	Click <b>Apply</b> to save your changes to the Switch's run-time memory. The Switch loses these changes if it is turned off or loses power, so use the <b>Save</b> link on the top navigation panel to save your changes to the non-volatile memory when you are done configuring.
Cancel	Click <b>Cancel</b> to begin configuring this screen afresh.

## 25.10 Remote Management

From the **Access Control** screen, display the **Remote Management** screen as shown next.

You can specify a group of one or more “trusted computers” from which an administrator may use a service to manage the Switch. Click **Access Control** to return to the **Access Control** screen.

**Figure 114** Management > Access Control > Remote Management

Entry	Active	Start Address	End Address	Telnet	FTP	HTTP	ICMP	SNMP	SSH	HTTPS
1	<input checked="" type="checkbox"/>	0.0.0.0	0.0.0.0	<input checked="" type="checkbox"/>	<input checked="" type="checkbox"/>	<input checked="" type="checkbox"/>	<input checked="" type="checkbox"/>	<input checked="" type="checkbox"/>	<input checked="" type="checkbox"/>	<input checked="" type="checkbox"/>
2	<input type="checkbox"/>	0.0.0.0	0.0.0.0	<input type="checkbox"/>	<input type="checkbox"/>	<input type="checkbox"/>	<input type="checkbox"/>	<input type="checkbox"/>	<input type="checkbox"/>	<input type="checkbox"/>
3	<input type="checkbox"/>	0.0.0.0	0.0.0.0	<input type="checkbox"/>	<input type="checkbox"/>	<input type="checkbox"/>	<input type="checkbox"/>	<input type="checkbox"/>	<input type="checkbox"/>	<input type="checkbox"/>
4	<input type="checkbox"/>	0.0.0.0	0.0.0.0	<input type="checkbox"/>	<input type="checkbox"/>	<input type="checkbox"/>	<input type="checkbox"/>	<input type="checkbox"/>	<input type="checkbox"/>	<input type="checkbox"/>

The following table describes the labels in this screen.

**Table 75** Management > Access Control > Remote Management

LABEL	DESCRIPTION
Entry	This is the client set index number. A “client set” is a group of one or more “trusted computers” from which an administrator may use a service to manage the Switch.
Active	Select this check box to activate this secured client set. Clear the check box if you wish to temporarily disable the set without deleting it.
Start Address End Address	Configure the IP address range of trusted computers from which you can manage this Switch. The Switch checks if the client IP address of a computer requesting a service or protocol matches the range set here. The Switch immediately disconnects the session if it does not match.

**Table 75** Management > Access Control > Remote Management (continued)

LABEL	DESCRIPTION
Telnet/FTP/ HTTP/ICMP/ SNMP/SSH/ HTTPS	Select services that may be used for managing the Switch from the specified trusted computers.
Apply	Click <b>Apply</b> to save your changes to the Switch's run-time memory. The Switch loses these changes if it is turned off or loses power, so use the <b>Save</b> link on the top navigation panel to save your changes to the non-volatile memory when you are done configuring.
Cancel	Click <b>Cancel</b> to begin configuring this screen afresh.



# Diagnostic

This chapter explains the **Diagnostic** screen.

## 26.1 Diagnostic

Click **Management > Diagnostic** in the navigation panel to open this screen. Use this screen to check system logs, ping IP addresses or perform port tests.

**Figure 115** Management > Diagnostic

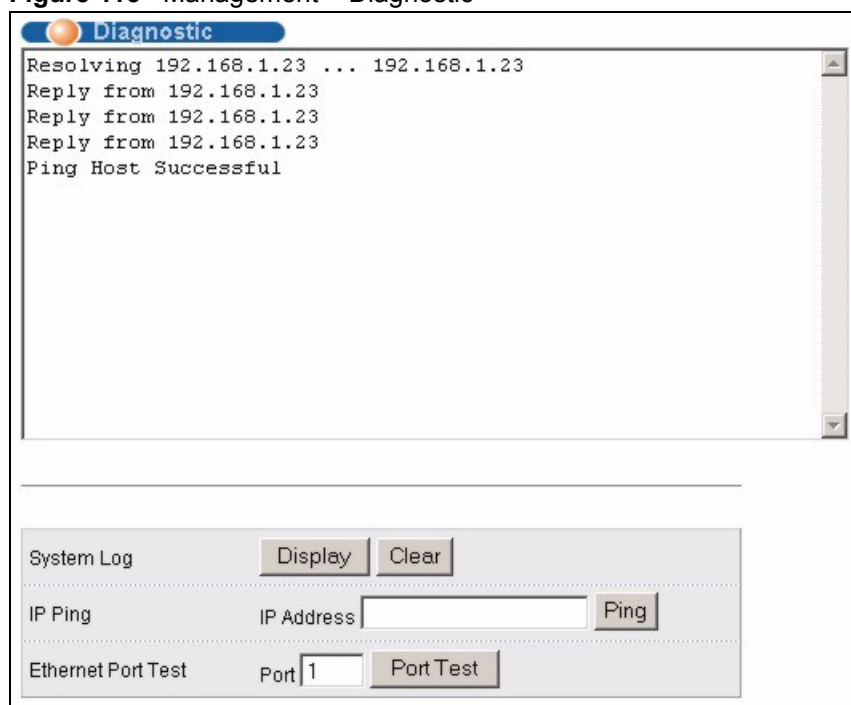

The following table describes the labels in this screen.

**Table 76** Management > Diagnostic

LABEL	DESCRIPTION
System Log	Click <b>Display</b> to display a log of events in the multi-line text box. Click <b>Clear</b> to empty the text box and reset the syslog entry.
IP Ping	Type the IP address of a device that you want to ping in order to test a connection. Click <b>Ping</b> to have the Switch ping the IP address (in the field to the left).
Ethernet Port Test	Enter a port number and click <b>Port Test</b> to perform an internal loopback test.





# Syslog

This chapter explains the syslog screens.

## 27.1 Syslog Overview

The syslog protocol allows devices to send event notification messages across an IP network to syslog servers that collect the event messages. A syslog-enabled device can generate a syslog message and send it to a syslog server.

Syslog is defined in RFC 3164. The RFC defines the packet format, content and system log related information of syslog messages. Each syslog message has a facility and severity level. The syslog facility identifies a file in the syslog server. Refer to the documentation of your syslog program for details. The following table describes the syslog severity levels.

**Table 77** Syslog Severity Levels

CODE	SEVERITY
0	Emergency: The system is unusable.
1	Alert: Action must be taken immediately.
2	Critical: The system condition is critical.
3	Error: There is an error condition on the system.
4	Warning: There is a warning condition on the system.
5	Notice: There is a normal but significant condition on the system.
6	Informational: The syslog contains an informational message.
7	Debug: The message is intended for debug-level purposes.

## 27.2 Syslog Setup

Click **Management** > **Syslog** in the navigation panel to display this screen. The syslog feature sends logs to an external syslog server. Use this screen to configure the device's system logging settings.

**Figure 116** Management > Syslog

Logging type	Active	Facility
System	<input checked="" type="checkbox"/>	local use 0
Interface	<input checked="" type="checkbox"/>	local use 0
Switch	<input checked="" type="checkbox"/>	local use 0
AAA	<input checked="" type="checkbox"/>	local use 0
IP	<input checked="" type="checkbox"/>	local use 0

The following table describes the labels in this screen.

**Table 78** Management > Syslog

LABEL	DESCRIPTION
Syslog	Select <b>Active</b> to turn on syslog (system logging) and then configure the syslog setting
Logging Type	This column displays the names of the categories of logs that the device can generate.
Active	Select this option to set the device to generate logs for the corresponding category.
Facility	The log facility allows you to send logs to different files in the syslog server. Refer to the documentation of your syslog program for more details.
Apply	Click <b>Apply</b> to save your changes to the Switch's run-time memory. The Switch loses these changes if it is turned off or loses power, so use the <b>Save</b> link on the top navigation panel to save your changes to the non-volatile memory when you are done configuring.
Cancel	Click <b>Cancel</b> to begin configuring this screen afresh.

## 27.3 Syslog Server Setup

Click **Management > Syslog > Syslog Server Setup** to open the following screen. Use this screen to configure a list of external syslog servers.

**Figure 117** Management > Syslog > Server Setup

The following table describes the labels in this screen.

**Table 79** Management > Syslog > Server Setup

LABEL	DESCRIPTION
Active	Select this check box to have the device send logs to this syslog server. Clear the check box if you want to create a syslog server entry but not have the device send logs to it (you can edit the entry later).
Server Address	Enter the IP address of the syslog server.
Log Level	Select the severity level(s) of the logs that you want the device to send to this syslog server. The lower the number, the more critical the logs are.
Add	Click <b>Add</b> to save your changes to the Switch's run-time memory. The Switch loses these changes if it is turned off or loses power, so use the <b>Save</b> link on the top navigation panel to save your changes to the non-volatile memory when you are done configuring.
Cancel	Click <b>Cancel</b> to begin configuring this screen afresh.
Clear	Click <b>Clear</b> to return the fields to the factory defaults.
Index	This is the index number of a syslog server entry. Click this number to edit the entry.
Active	This field displays <b>Yes</b> if the device is to send logs to the syslog server. <b>No</b> displays if the device is not to send logs to the syslog server.
IP Address	This field displays the IP address of the syslog server.
Log Level	This field displays the severity level of the logs that the device is to send to this syslog server.
Delete	Select an entry's <b>Delete</b> check box and click <b>Delete</b> to remove the entry.
Cancel	Click <b>Cancel</b> to begin configuring this screen afresh.



# Cluster Management

This chapter introduces cluster management.

## 28.1 Clustering Management Status Overview

Cluster Management allows you to manage switches through one Switch, called the cluster manager. The switches must be directly connected and be in the same VLAN group so as to be able to communicate with one another.

**Table 80** ZyXEL Clustering Management Specifications

Maximum number of cluster members	24
Cluster Member Models	Cluster member models must be compatible with ZyXEL cluster management implementation.
Cluster Manager	The cluster manager is the Switch through which you manage the cluster member switches.
Cluster Members	Cluster members are the switches being managed by the cluster manager switch.

In the following example, switch **A** in the basement is the cluster manager and the other switches on the upper floors of the building are cluster members.

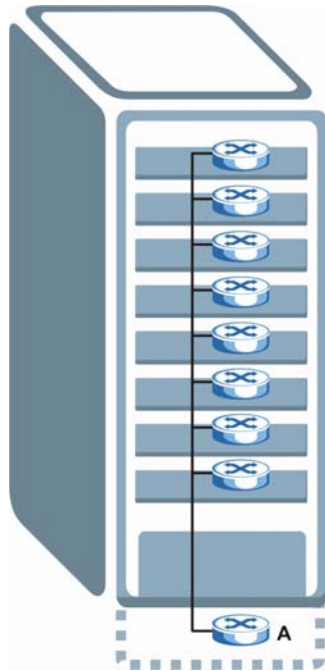
**Figure 118** Clustering Application Example

## 28.2 Cluster Management Status

Click **Management > Cluster Management** in the navigation panel to display the following screen.



A cluster can only have one manager.

**Figure 119** Management > Cluster Management

Clustering Management Status		<a href="#">Configuration</a>		
Status	Manager			
Manager	00:13:49:01:1f:b0			
<b>The Number Of Member = 1</b>				
Index	MacAddr	Name	Model	Status
1	00:13:49:ae:fb:7a	ES-2024PWR	ES-2024PWR	Online

The following table describes the labels in this screen.

**Table 81** Management > Cluster Management

LABEL	DESCRIPTION
Status	This field displays the role of this Switch within the cluster. <b>Manager</b> <b>Member</b> (you see this if you access this screen in the cluster member switch directly and not via the cluster manager) <b>None</b> (neither a manager nor a member of a cluster)
Manager	This field displays the cluster manager switch's hardware MAC address.
The Number of Member	This field displays the number of switches that make up this cluster. The following fields describe the cluster member switches.
Index	You can manage cluster member switches via the cluster manager switch. Each number in the <b>Index</b> column is a hyperlink leading to the cluster member switch's web configurator (see <a href="#">Figure 120 on page 207</a> ).
MacAddr	This is the cluster member switch's hardware MAC address.
Name	This is the cluster member switch's <b>System Name</b> .
Model	This field displays the model name.
Status	This field displays: <b>Online</b> (the cluster member switch is accessible) <b>Error</b> (for example, the cluster member switch password was changed or the switch was set as the manager and so left the member list, etc.) <b>Offline</b> (the switch is disconnected - <b>Offline</b> shows approximately 1.5 minutes after the link between cluster member and manager goes down)

## 28.2.1 Cluster Member Switch Management

Go to the **Clustering Management Status** screen of the cluster manager switch and then select an **Index** hyperlink from the list of members to go to that cluster member switch's web configurator home page. This cluster member web configurator home page and the home page that you'd see if you accessed it directly are different.

**Figure 120** Cluster Management: Cluster Member Web Configurator Screen



### 28.2.1.1 Uploading Firmware to a Cluster Member Switch

You can use FTP to upload firmware to a cluster member switch through the cluster manager switch as shown in the following example.

**Figure 121** Example: Uploading Firmware to a Cluster Member Switch

```
C:\>ftp 192.168.1.1
Connected to 192.168.1.1.
220 Switch FTP version 1.0 ready at Thu Jan  1 00:58:46 1970
User (192.168.0.1:(none)): admin
331 Enter PASS command
Password:
230 Logged in
ftp> ls
200 Port command okay
150 Opening data connection for LIST
--w--w--w-  1 owner   group      3042210 Jul 01 12:00 ras
-rw-rw-rw-  1 owner   group      393216 Jul 01 12:00 config
--w--w--w-  1 owner   group         0 Jul 01 12:00 fw-00-a0-c5-01-23-46
-rw-rw-rw-  1 owner   group         0 Jul 01 12:00 config-00-a0-c5-01-23-46
226 File sent OK
ftp: 297 bytes received in 0.00Seconds 297000.00Kbytes/sec.
ftp> bin
200 Type I OK
ftp> put 3701t0.bin fw-00-a0-c5-01-23-46
200 Port command okay
150 Opening data connection for STOR fw-00-a0-c5-01-23-46
226 File received OK
ftp: 262144 bytes sent in 0.63Seconds 415.44Kbytes/sec.
ftp>
```

The following table explains some of the FTP parameters.

**Table 82** FTP Upload to Cluster Member Example

FTP PARAMETER	DESCRIPTION
User	Enter "admin".
Password	The web configurator password default is 1234.
ls	Enter this command to list the name of cluster member switch's firmware and configuration file.
3701t0.bin	This is the name of the firmware file you want to upload to the cluster member switch.
fw-00-a0-c5-01-23-46	This is the cluster member switch's firmware name as seen in the cluster manager switch.
config-00-a0-c5-01-23-46	This is the cluster member switch's configuration file name as seen in the cluster manager switch.

## 28.3 Clustering Management Configuration

Use this screen to configure clustering management. Click **Configuration** from the **Cluster Management** screen to display the next screen.



**Figure 122** Management > Clustering Management > Configuration

**Clustering Manager:**

Active

Name

VID

**Clustering Candidate:**

List

00:13:49:00:00:01/ES-2108-G/ES-2108-G  
00:13:49:00:00:02/GS-3012/GS-3012

Password

Index	MacAddr	Name	Model	Remove
1	00:13:49:ae:fb:7a	ES-2024PWR	ES-2024PWR	<input type="checkbox"/>

The following table describes the labels in this screen.

**Table 83** Management > Clustering Management > Configuration

LABEL	DESCRIPTION
Clustering Manager	
Active	Select <b>Active</b> to have this Switch become the cluster manager switch. A cluster can only have one manager. Other (directly connected) switches that are set to be cluster managers will not be visible in the <b>Clustering Candidates</b> list. If a switch that was previously a cluster member is later set to become a cluster manager, then its <b>Status</b> is displayed as <b>Error</b> in the <b>Cluster Management Status</b> screen and a warning icon (  ) appears in the member summary list below.
Name	Type a name to identify the <b>Clustering Manager</b> . You may use up to 32 printable characters (spaces are allowed).
VID	This is the VLAN ID and is only applicable if the Switch is set to <b>802.1Q</b> VLAN. All switches must be directly connected and in the same VLAN group to belong to the same cluster. Switches that are not in the same VLAN group are not visible in the <b>Clustering Candidates</b> list. This field is ignored if the <b>Clustering Manager</b> is using <b>Port-based</b> VLAN.
Apply	Click <b>Apply</b> to save your changes to the Switch's run-time memory. The Switch loses these changes if it is turned off or loses power, so use the <b>Save</b> link on the top navigation panel to save your changes to the non-volatile memory when you are done configuring.
Cancel	Click <b>Cancel</b> to begin configuring this screen afresh.

**Table 83** Management > Clustering Management > Configuration (continued)

LABEL	DESCRIPTION
Clustering Candidate	The following fields relate to the switches that are potential cluster members.
List	A list of suitable candidates found by auto-discovery is shown here. The switches must be directly connected. Directly connected switches that are set to be cluster managers will not be visible in the <b>Clustering Candidate</b> list. Switches that are not in the same management VLAN group will not be visible in the <b>Clustering Candidate</b> list.
Password	Each cluster member's password is its web configurator password. Select a member in the <b>Clustering Candidate</b> list and then enter its web configurator password. If that switch administrator changes the web configurator password afterwards, then it cannot be managed from the <b>Cluster Manager</b> . Its <b>Status</b> is displayed as <b>Error</b> in the <b>Cluster Management Status</b> screen and a warning icon (  ) appears in the member summary list below. If multiple devices have the same password then hold [SHIFT] and click those switches to select them. Then enter their common web configurator password.
Add	Click <b>Add</b> to save your changes to the Switch's run-time memory. The Switch loses these changes if it is turned off or loses power, so use the <b>Save</b> link on the top navigation panel to save your changes to the non-volatile memory when you are done configuring.
Cancel	Click <b>Cancel</b> to begin configuring this screen afresh.
Refresh	Click <b>Refresh</b> to perform auto-discovery again to list potential cluster members.
The next summary table shows the information for the clustering members configured.	
Index	This is the index number of a cluster member switch.
MacAddr	This is the cluster member switch's hardware MAC address.
Name	This is the cluster member switch's <b>System Name</b> .
Model	This is the cluster member switch's model name.
Remove	Select this checkbox and then click the <b>Remove</b> button to remove a cluster member switch from the cluster.
Cancel	Click <b>Cancel</b> to begin configuring this screen afresh.

# MAC Table

This chapter introduces the **MAC Table** screen.

## 29.1 MAC Table Overview

The **MAC Table** screen (a MAC table is also known as a filtering database) shows how frames are forwarded or filtered across the Switch's ports. When a device (which may belong to a VLAN group) sends a packet which is forwarded to a port on the Switch, the MAC address of the device is shown on the Switch's **MAC Table**. It also shows whether the MAC address is dynamic (learned by the Switch) or static (manually entered in the **Static MAC Forwarding** screen).

The Switch uses the **MAC Table** to determine how to forward frames. See the following figure.

- 1 The Switch examines a received frame and learns the port from which this source MAC address came.
  - 2 The Switch checks to see if the frame's destination MAC address matches a source MAC address already learned in the **MAC Table**.
- If the Switch has already learned the port for this MAC address, then it forwards the frame to that port.
  - If the Switch has not already learned the port for this MAC address, then the frame is flooded to all ports. Too much port flooding leads to network congestion.
  - If the Switch has already learned the port for this MAC address, but the destination port is the same as the port it came in on, then it filters the frame.

Figure 123 MAC Table Flowchart

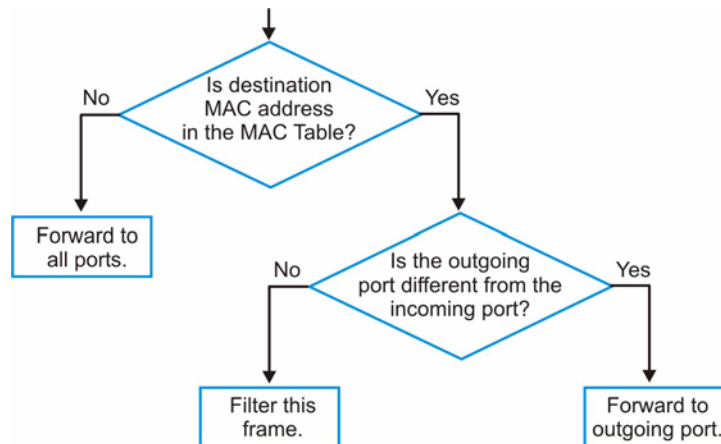

## 29.2 Viewing the MAC Table

Click **Management > MAC Table** in the navigation panel to display the following screen.

Figure 124 Management &gt; MAC Table

Index	MAC Address	VID	Port	Type
1	00:85:a0:01:01:00	1	8	dynamic
2	00:85:a0:01:01:04	1	8	dynamic
3	00:a0:c5:00:00:01	1	2	dynamic
4	00:a0:c5:fe:ea:71	1	CPU	static
5	00:a0:c5:fe:ea:71	2	CPU	static

The following table describes the labels in this screen.

Table 84 Management &gt; MAC Table

LABEL	DESCRIPTION
Sort by	Click one of the following buttons to display and arrange the data according to that button type. The information is then displayed in the summary table below.
MAC	Click this button to display and arrange the data according to MAC address.
VID	Click this button to display and arrange the data according to VLAN group.
Port	Click this button to display and arrange the data according to port number.
Index	This is the incoming frame index number.
MAC Address	This is the MAC address of the device from which this incoming frame came.
VID	This is the VLAN group to which this frame belongs.
Port	This is the port from which the above MAC address was learned.
Type	This shows whether the MAC address is <b>dynamic</b> (learned by the Switch) or <b>static</b> (manually entered in the <b>Static MAC Forwarding</b> screen).

# ARP Table

This chapter introduces ARP Table.

## 30.1 ARP Table Overview

Address Resolution Protocol (ARP) is a protocol for mapping an Internet Protocol address (IP address) to a physical machine address, also known as a Media Access Control or MAC address, on the local area network.

An IP (version 4) address is 32 bits long. In an Ethernet LAN, MAC addresses are 48 bits long. The ARP Table maintains an association between each MAC address and its corresponding IP address.

### 30.1.1 How ARP Works

When an incoming packet destined for a host device on a local area network arrives at the Switch, the Switch's ARP program looks in the ARP Table and if it finds the address, it sends it to the device.

If no entry is found for the IP address, ARP broadcasts the request to all the devices on the LAN. The Switch fills in its own MAC and IP address in the sender address fields, and puts the known IP address of the target in the target IP address field. In addition, the Switch puts all ones in the target MAC field (FF.FF.FF.FF.FF.FF is the Ethernet broadcast address). The replying device (which is either the IP address of the device being sought or the router that knows the way) replaces the broadcast address with the target's MAC address, swaps the sender and target pairs, and unicasts the answer directly back to the requesting machine. ARP updates the ARP Table for future reference and then sends the packet to the MAC address that replied.

## 30.2 Viewing the ARP Table

Click **Management** > **ARP Table** in the navigation panel to open the following screen. Use the ARP table to view IP-to-MAC address mapping(s).

**Figure 125** Management > ARP Table

ARP Table			
Index	IP Address	MAC Address	Type
1	172.21.0.2	00:05:5d:04:30:f1	dynamic
2	172.21.3.16	00:05:1c:15:08:71	dynamic
3	172.21.3.19	00:0b:cd:8c:6d:ed	dynamic
4	172.21.3.40	00:0c:76:07:41:0d	dynamic
5	172.21.3.66	00:50:8d:47:73:4f	dynamic
6	172.21.3.90	00:05:5d:f4:49:20	dynamic
7	172.21.3.91	00:50:ba:ad:56:7c	dynamic
8	172.21.3.95	00:10:b5:ae:56:97	dynamic
9	172.21.3.120	00:10:b5:ae:62:32	dynamic
10	172.21.3.138	00:a0:c5:b2:62:26	dynamic
11	172.21.4.99	00:0c:76:09:cf:88	dynamic
12	172.21.10.11	08:00:20:ad:f6:88	dynamic
13	172.21.100.153	00:90:27:be:a2:8c	dynamic
14	172.21.207.247	00:0c:76:09:17:1a	dynamic
15	192.168.1.1	00:a0:c5:3f:91:56	dynamic
16	192.168.1.5	00:85:a0:01:01:04	dynamic
17	192.168.1.10	00:a0:c5:5e:df:f9	static
18	192.168.1.100	00:85:a0:01:01:00	dynamic

The following table describes the labels in this screen.

**Table 85** Management > ARP Table

LABEL	DESCRIPTION
Index	This is the ARP Table entry number.
IP Address	This is the learned IP address of a device connected to a Switch port with the corresponding MAC address below.
MAC Address	This is the MAC address of the device with the corresponding IP address above.
Type	This shows whether the MAC address is dynamic (learned by the Switch) or static (manually entered in the <b>Static MAC Forwarding</b> screen).

# Configure Clone

This chapter shows you how you can copy the settings of one port onto other ports.

## 31.1 Configure Clone

Cloning allows you to copy the basic and advanced settings from a source port to a destination port or ports. Click **Management > Configure Clone** to open the following screen.

**Figure 126** Management > Configure Clone

**Configure Clone**

Source      Destination

Port      

**Port Features**

**Basic Setting**

- Active
- Name
- Speed / Duplex
- Flow Control
- Intrusion Lock

**Advanced Application**

- VLAN1q
- VLAN1q Member
- Bandwidth Control
- Port Security
- Broadcast Storm Control
- Port Authentication
- IGMP Filtering
- Spanning Tree Protocol
- Port-based VLAN
- Loop Guard

The following table describes the labels in this screen.

**Table 86** Management > Configure Clone

LABEL	DESCRIPTION
Source/ Destination Port	Enter the source port under the <b>Source</b> label. This port's attributes are copied. Enter the destination port or ports under the <b>Destination</b> label. These are the ports which are going to have the same attributes as the source port. You can enter individual ports separated by a comma or a range of ports by using a dash. Example: <ul style="list-style-type: none"><li>• <b>2, 4, 6</b> indicates that ports 2, 4 and 6 are the destination ports.</li><li>• <b>2-6</b> indicates that ports 2 through 6 are the destination ports.</li></ul>
Basic Setting	Select which port settings (configured in the <b>Basic Setting</b> menus) should be copied to the destination port(s).
Advanced Application	Select which port settings (configured in the <b>Advanced Application</b> menus) should be copied to the destination ports.
Apply	Click <b>Apply</b> to save your changes to the Switch's run-time memory. The Switch loses these changes if it is turned off or loses power, so use the <b>Save</b> link on the top navigation panel to save your changes to the non-volatile memory when you are done configuring.
Cancel	Click <b>Cancel</b> to begin configuring this screen afresh.



---

# **PART VI**

# **Troubleshooting & Product Specifications**

---

Troubleshooting (219)

Product Specifications (223)



# Troubleshooting

This chapter offers some suggestions to solve problems you might encounter. The potential problems are divided into the following categories.

- [Power, Hardware Connections, and LEDs](#)
- [Switch Access and Login](#)

## 32.1 Power, Hardware Connections, and LEDs



---

The Switch does not turn on. None of the LEDs turn on.

---

- 1 Make sure you are using the power adaptor or cord included with the Switch.
- 2 Make sure the power adaptor or cord is connected to the Switch and plugged in to an appropriate power source. Make sure the power source is turned on.
- 3 Disconnect and re-connect the power adaptor or cord to the Switch.
- 4 If the problem continues, contact the vendor.



---

The **ALARM/ALM** LED is on.

---

- 1 Disconnect and re-connect the power adaptor to the Switch.
- 2 If the problem continues, contact the vendor.



---

One of the LEDs does not behave as expected.

---

- 1 Make sure you understand the normal behavior of the LED. See [Section 3.3 on page 41](#).
- 2 Check the hardware connections. See [Chapter 2 on page 33](#) and [Chapter 3 on page 37](#).
- 3 Inspect your cables for damage. Contact the vendor to replace any damaged cables.
- 4 Disconnect and re-connect the power adaptor to the Switch.
- 5 If the problem continues, contact the vendor.

## 32.2 Switch Access and Login



---

I forgot the IP address for the Switch.

---

- 1 The default IP address is **192.168.1.1**.
- 2 Use the console port to log in to the Switch.
- 3 Use the management port to log in to the Switch.
- 4 If this does not work, you have to reset the device to its factory defaults. See [Section 4.6 on page 51](#).



---

I forgot the password.

---

- 1 The default password is **1234**.
- 2 If this does not work, you have to reset the device to its factory defaults. See [Section 32.1 on page 219](#).



---

I cannot see or access the **Login** screen in the web configurator.

---

- 1 Make sure you are using the correct IP address.
  - The default IP address is [192.168.1.1](#).
  - If you changed the IP address ([Section 7.6 on page 69](#)), use the new IP address.
  - If you changed the IP address and have forgotten it, see the troubleshooting suggestions for [I forgot the IP address for the Switch](#).
- 2 Check the hardware connections, and make sure the LEDs are behaving as expected. See [Section 3.3 on page 41](#).
- 3 Make sure your Internet browser does not block pop-up windows and has JavaScripts and Java enabled. See [Appendix A on page 233](#).
- 4 Make sure your computer is in the same subnet as the Switch. (If you know that there are routers between your computer and the Switch, skip this step.)
- 5 Reset the device to its factory defaults, and try to access the Switch with the default IP address. See [Section 4.6 on page 51](#).
- 6 If the problem continues, contact the network administrator or vendor, or try one of the advanced suggestions.

### Advanced Suggestions

- Try to access the Switch using another service, such as Telnet. If you can access the Switch, check the remote management settings and secured client settings to find out why the Switch does not respond to HTTP.



---

I can see the **Login** screen, but I cannot log in to the Switch.

---

- 1 Make sure you have entered the user name and password correctly. The default user name is **admin**, and the default password is **1234**. These fields are case-sensitive, so make sure [Caps Lock] is not on.
- 2 You cannot log in to the web configurator while someone is using Telnet or the console port to access the Switch. Log out of the Switch in the other session, or ask the person who is logged in to log out.
- 3 Disconnect and re-connect the power adaptor or cord to the Switch.
- 4 If this does not work, you have to reset the device to its factory defaults. See [Section 32.1 on page 219](#).



---

I cannot access the SMT. / I cannot Telnet to the Switch.

---

- 1 You may have exceeded the maximum number of concurrent Telnet sessions. See [Section 25.1 on page 181](#). If you have exceeded the maximum number, close other Telnet sessions, or try connecting again later.
- 2 See the troubleshooting suggestions for [I cannot see or access the Login screen in the web configurator](#). Ignore the suggestions about your browser.



---

I cannot use FTP to upload / download the configuration file. / I cannot use FTP to upload new firmware.

---

See the troubleshooting suggestions for [I cannot see or access the Login screen in the web configurator](#). Ignore the suggestions about your browser.



# Product Specifications

The following tables summarize the Switch's hardware and firmware features.

**Table 87** Hardware Specifications

SPECIFICATION	DESCRIPTION
Dimensions	438(W) x 270(D) x 44.45(H) mm (17.2(W) x 10.6(D) x 1.75(H) inches), 19-inch rack-mount width, 1 U height
Weight	3.8 kg
Power Specification	100-240 VAC, 50 / 60 Hz, 70 W
Interfaces	24 RJ-45 connectors for 100/1000Mbps Ethernet ports Two mini GBIC (SFP) slots which are shared with port 23/24 copper ports One DB-9/female (DCE) connector for console port One RJ-45 connector for 10/100Mbps out-of-band management port
Ethernet Ports	Auto-negotiating: 10 Mbps or 100 Mbps in either half-duplex or full-duplex mode. 1000 Mbps in full duplex. Auto-crossover: Use either crossover or straight-through Ethernet cables. Auto-MDIX Compliant with IEEE 802.3ad/u/x Back pressure flow control for half duplex Flow control for full duplex (IEEE 802.3x)
Operating Environment	Temperature: 0° C ~ 45° C (32° F ~ 113° F) Humidity: 10 ~ 90% (non-condensing)
Storage Environment	Temperature: -25° C ~ 70° C (-13° F ~ 158° F) Humidity: 10 ~ 90% (non-condensing)
System Monitoring	Voltage: 12V +/- 10% 5.0V +/- 5% 3.3V +/- 5% 2.5V +/- 5% 1.8V +/- 5% 1.3V +/- 5% 1.2V +/- 5% Temperature: MAC CPU PHY Fan detection: 4500-6500 rpm

**Table 87** Hardware Specifications

Safety	UL 60950-1 CSA 60950-1 EN 60950-1 IEC 60950-1
EMC	FCC Part 15 (Class A) CE EMC (Class A)

**Table 88** Firmware Specifications

FEATURE	DESCRIPTION
Default IP Address	In band: 192.168.1.1 Out of band (Management port): 192.168.0.1
Default Subnet Mask	255.255.255.0 (24 bits)
Administrator User Name	admin
Default Password	1234
Number of Login Accounts Configurable on the Switch	4 management accounts configured on the Switch. Authentication via RADIUS and TACACS+ also available.
VLAN	A VLAN (Virtual Local Area Network) allows a physical network to be partitioned into multiple logical networks. Devices on a logical network belong to one group. A device can belong to more than one group. With VLAN, a device cannot directly talk to or hear from devices that are not in the same group(s); the traffic must first go through a router.
IGMP Snooping	The Switch supports IGMP snooping enabling group multicast traffic to be only forwarded to ports that are members of that group; thus allowing you to significantly reduce multicast traffic passing through your Switch.
Differentiated Services (DiffServ)	With DiffServ, the Switch marks packets so that they receive specific per-hop treatment at DiffServ-compliant network devices along the route based on the application types and traffic flow.
Queuing	Queuing is used to help solve performance degradation when there is network congestion. These scheduling services are supported: Strict Priority Queuing (SPQ) and Weighted Round Robin (WRR). This allows the Switch to maintain separate queues for packets from each individual source or flow and prevent a source from monopolizing the bandwidth.
Port Mirroring	Port mirroring allows you to copy traffic going from one or all ports to another or all ports in order that you can examine the traffic from the mirror port (the port you copy the traffic to) without interference.
Static Route	Static routes tell the Switch how to forward IP traffic when you configure the TCP/IP parameters manually.
Multicast VLAN Registration (MVR)	Multicast VLAN Registration (MVR) is designed for applications (such as Media-on-Demand (MoD)) using multicast traffic across a network. MVR allows one single multicast VLAN to be shared among different subscriber VLANs on the network. This improves bandwidth utilization by reducing multicast traffic in the subscriber VLANs and simplifies multicast group management.
STP (Spanning Tree Protocol) / RSTP (Rapid STP)	(R)STP detects and breaks network loops and provides backup links between switches, bridges or routers. It allows a Switch to interact with other (R)STP-compliant switches in your network to ensure that only one path exists between any two stations on the network.
Loop Guard	Use the loop guard feature to protect against network loops on the edge of your network.



**Table 88** Firmware Specifications

FEATURE	DESCRIPTION
Link Aggregation	Link aggregation (trunking) is the grouping of physical ports into one logical higher-capacity link. You may want to trunk ports if for example, it is cheaper to use multiple lower-speed links than to under-utilize a high-speed, but more costly, single-port link.
Port Authentication and Security	For security, the Switch allows authentication using IEEE 802.1x with an external RADIUS server and port security that allows only packets with dynamically learned MAC addresses and/or configured static MAC addresses to pass through a port on the Switch.
Authentication and Accounting	The Switch supports authentication and accounting services via RADIUS and TACACS+ AAA servers.
Device Management	Use the web configurator or commands to easily configure the rich range of features on the Switch.
Port Cloning	Use the port cloning feature to copy the settings you configure on one port to another port or ports.
Syslog	The Switch can generate syslog messages and send it to a syslog server.
Firmware Upgrade	Download new firmware (when available) from the ZyXEL web site and use the web configurator, CLI or an FTP/TFTP tool to put it on the Switch.  <b>Note: Only upload firmware for your specific model!</b>
Configuration Backup & Restoration	Make a copy of the Switch's configuration and put it back on the Switch later if you decide you want to revert back to an earlier configuration.
Cluster Management	Cluster management (also known as iStacking) allows you to manage switches through one switch, called the cluster manager. The switches must be directly connected and be in the same VLAN group so as to be able to communicate with one another.
Static MAC Forwarding	Static MAC forwarding lets you configure forwarding rules based on the MAC addresses of devices on your network.
MSTP	Multiple Spanning Tree Protocol (IEEE 802.1s) is backwards-compatible with STP/RSTP and addresses the limitations of existing spanning tree protocols (STP and RSTP).
SNMP v3	SNMP v3 enhances security for SNMP management. SNMP managers can be required to authenticate with agents before conducting SNMP management sessions.
SNMP Trap Group	You can specify the types of SNMP traps that should be sent to each SNMP manager.
Daylight Saving Time	Daylight saving is a period from late spring to early fall when many countries set their clocks ahead of normal local time by one hour to give more daytime light in the evening.
DHCP Relay	The Switch can forward DHCP requests to DHCP servers on your network.

**Table 89** Switching Specifications

Layer 2 Features	Bridging	8K MAC addresses (hashed) Static MAC address forwarding: 256 entries Broadcast storm control in frames/sec Automatic address learning and aging Aging time: 14bits resolution in (1s/10ms/1min/5min), default 300 secs
	Switching	Switching fabric: 48 Gbps, non-blocking Store and forward Forwarding rate: 1488000 in 1000 Mbps, 148800 in 100 Mbps Maximum frame size: 9216 bytes in jumbo frame, 1522 bytes in standard
	STP	IEEE 802.1w Rapid Spanning Tree Protocol (RSTP) IEEE 802.1s Multiple Spanning Tree Protocol (MSTP)
	QoS	IEEE 802.1p compliant 4 queues per output port in priority weight round robin algorithm DiffServ (DSCP to output queue mapping)* IGMP snooping (IGMP v1/v2/v3, 16 VLAN maximum-user configurable)
	VLAN	Port-based VLAN 802.1Q VLAN full 4K groups support, 256 static VLAN GVRP for dynamic registration VLAN ingress filtering Acceptable frame type for all/tag only/untag only PVID ranging from 1 to 4094
	Link Aggregation	Supports IEEE 802.3ad; static and dynamic (LACP) port trunking Four groups (up to 8 ports each)
	Port Mirroring	Port based mirroring to a mirror port
	Bandwidth Control	Port-based bandwidth control for ingress (64K, 128K, 256K, 512K, 1M, 2M, 4M, 8M, 16M, 32M, 64M, 128M, 256M, 512M only)
Layer 3 Features	Multicast	IGMP snooping (IGMP v1/v2/v3, 16 VLAN maximum-user configurable) IGMP filtering MVR IGMP timer
	IP services	DHCP relay; VLAN based DHCP server/relay

**Table 89** Switching Specifications (continued)

Security	Static MAC forwarding, 64 entries Block unresolved address forwarding/Port security 802.1x port based authentication with RADIUS support SSH v1/v2 SSL Intrusion Lock Multiple RADIUS servers Multiple TACACS+ servers 802.1X VLAN and bandwidth assignment.
Management	Configuration by console/Telnet/web Firmware upgrade by FTP/web/console Configuration backup and restore by FTP/web/console System management access control Telnet (up to 9 sessions) System clock by manual setup or NTP Daylight saving time support RMON group 1,2,3,9 ICMP echo/echo reply System log (1000 entries) Out-of-band Ethernet, IP host only, non-VLAN aware SNMP v2c/v3, MIBS: RFC1213 RFC1157 RFC1493 bridge MIB RFC1643 Ethernet MIB RFC1757 RMON group 1,2,3,9 RFC2674 bridge MIB extension SNMP traps, 4 destination syslog Loop guard Accounting by RADIUS Accounting by TACACS+ Both cluster manager and client supported Up to 24 clients supported for a group

The following list, which is not exhaustive, illustrates the standards supported in the Switch.

**Table 90** Standards Supported

STANDARD	DESCRIPTION
RFC 826	Address Resolution Protocol (ARP)
RFC 867	Daytime Protocol
RFC 868	Time Protocol
RFC 1112	IGMP v1
RFC 1157	SNMPv1: Simple Network Management Protocol version 1
RFC 1213	SNMP MIB II
RFC 1305	Network Time Protocol (NTP version 3)
RFC 1441	SNMPv2 Simple Network Management Protocol version 2
RFC 1493	Bridge MIBs
RFC 1643	Ethernet MIBs

**Table 90** Standards Supported (continued)

STANDARD	DESCRIPTION
RFC 1757	RMON
RFC 1901	SNMPv2c Simple Network Management Protocol version 2c
RFC 2138	RADIUS (Remote Authentication Dial In User Service)
RFC 2139	RADIUS Accounting
RFC 2236	Internet Group Management Protocol, Version 2.
RFC 2865	RADIUS - Vendor Specific Attribute
RFC 2674	P-BRIDGE-MIB, Q-BRIDGE-MIB
RFC 3046	DHCP Relay
RFC 3164	Syslog
RFC 3376	Internet Group Management Protocol, Version 3
IEEE 802.1x	Port Based Network Access Control
IEEE 802.1D	MAC Bridges
IEEE 802.1p	Traffic Types - Packet Priority
IEEE 802.1Q	Tagged VLAN
IEEE 802.1w	Rapid Spanning Tree Protocol (RSTP)
IEEE 802.1s	Multiple Spanning Tree Protocol (MSTP)
IEEE 802.3	Packet Format
IEEE 802.3ad	Link Aggregation
IEEE 802.3x	Flow Control
IEEE 802.3z	1000BASE-X For optical fiber link 1000BASE-SX/LX.

## Cable Pin Assignments

In a serial communications connection, generally a computer is DTE (Data Terminal Equipment) and a modem is DCE (Data Circuit-terminating Equipment). The Switch is DCE when you connect a computer to the console port. The Switch is DTE when you connect a modem to the dial backup port.<sup>3</sup>

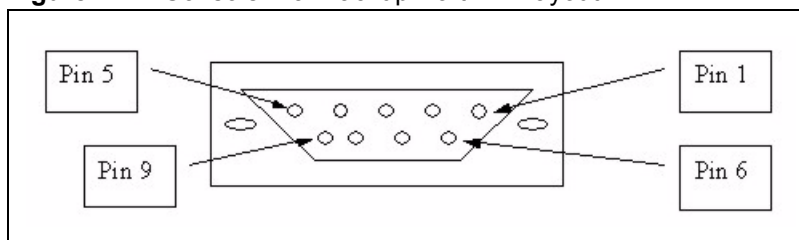
**Figure 127** Console/Dial Backup Port Pin Layout

3. Pins 2,3 and 5 are used.

**Table 91** Console/Dial Backup Port Pin Assignments

CONSOLE Port RS – 232 (Female) DB-9F	DIAL BACKUP RS – 232 (Male) DB-9M (Not on all models)
Pin 1 = NON Pin 2 = DCE-TXD Pin 3 = DCE –RXD Pin 4 = DCE –DSR Pin 5 = GND Pin 6 = DCE –DTR Pin 7 = DCE –CTS Pin 8 = DCE –RTS PIN 9 = NON	Pin 1 = NON Pin 2 = DTE-RXD Pin 3 = DTE-TXD Pin 4 = DTE-DTR Pin 5 = GND Pin 6 = DTE-DSR Pin 7 = DTE-RTS Pin 8 = DTE-CTS PIN 9 = NON.
The CON/AUX port also has these pin assignments. The CON/AUX switch changes the setting in the firmware only and does not change the CON/AUX port's pin assignments.	Switches with a CON/AUX port also have a 9-pin adaptor for the console cable with these pin assignments on the male end.

**Table 92** Ethernet Cable Pin Assignments

WAN / LAN ETHERNET CABLE PIN LAYOUT			
Straight-through		Crossover	
(Switch)	(Adapter)	(Switch)	(Switch)
1 IRD +	1 OTD +	1 IRD +	1 IRD +
2 IRD -	2 OTD -	2 IRD -	2 IRD -
3 OTD +	3 IRD +	3 OTD +	3 OTD +
6 OTD -	6 IRD -	6 OTD -	6 OTD -



---

# PART VII

## Appendices and Index

---

Pop-up Windows, JavaScripts and Java Permissions (233)

IP Addresses and Subnetting (241)

Legal Information (249)

Customer Support (253)

Index (259)





# Pop-up Windows, JavaScripts and Java Permissions

In order to use the web configurator you need to allow:

- Web browser pop-up windows from your device.
- JavaScripts (enabled by default).
- Java permissions (enabled by default).



---

Internet Explorer 6 screens are used here. Screens for other Internet Explorer versions may vary.

---

## Internet Explorer Pop-up Blockers

You may have to disable pop-up blocking to log into your device.

Either disable pop-up blocking (enabled by default in Windows XP SP (Service Pack) 2) or allow pop-up blocking and create an exception for your device's IP address.

### Disable Pop-up Blockers

- 1 In Internet Explorer, select **Tools, Pop-up Blocker** and then select **Turn Off Pop-up Blocker**.

**Figure 128** Pop-up Blocker

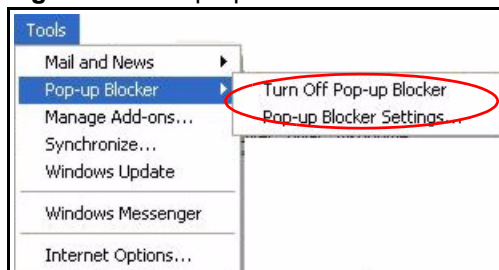

You can also check if pop-up blocking is disabled in the **Pop-up Blocker** section in the **Privacy** tab.

- 1 In Internet Explorer, select **Tools, Internet Options, Privacy**.

- 2 Clear the **Block pop-ups** check box in the **Pop-up Blocker** section of the screen. This disables any web pop-up blockers you may have enabled.

**Figure 129** Internet Options: Privacy

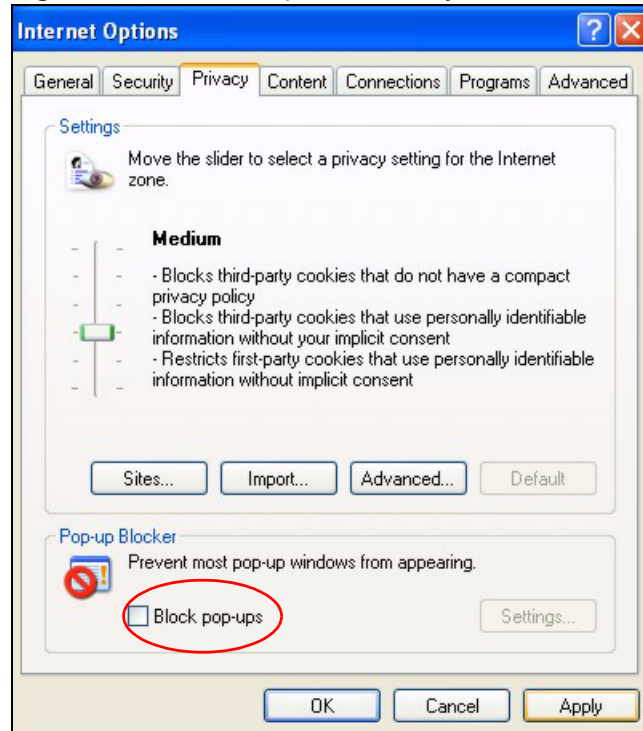

- 3 Click **Apply** to save this setting.

### Enable Pop-up Blockers with Exceptions

Alternatively, if you only want to allow pop-up windows from your device, see the following steps.

- 1 In Internet Explorer, select **Tools, Internet Options** and then the **Privacy** tab.
- 2 Select **Settings...** to open the **Pop-up Blocker Settings** screen.

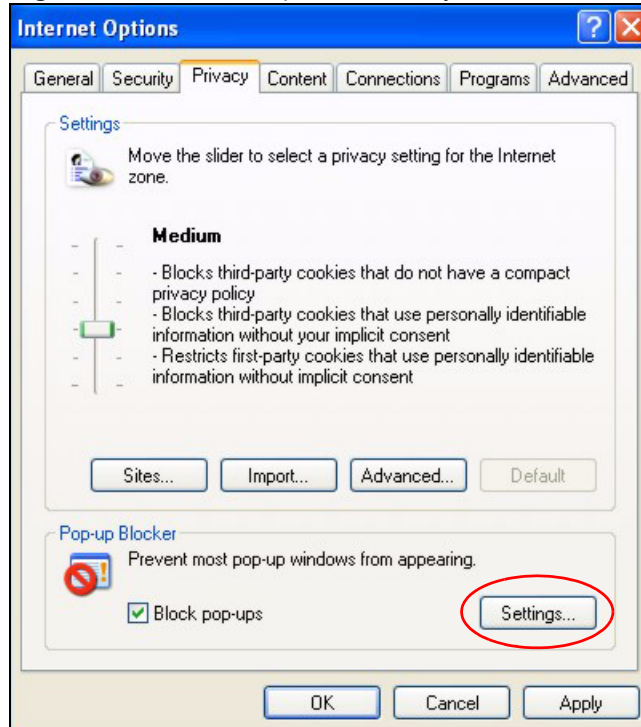
**Figure 130** Internet Options: Privacy

- 3 Type the IP address of your device (the web page that you do not want to have blocked) with the prefix "http://". For example, http://192.168.167.1.
- 4 Click **Add** to move the IP address to the list of **Allowed sites**.

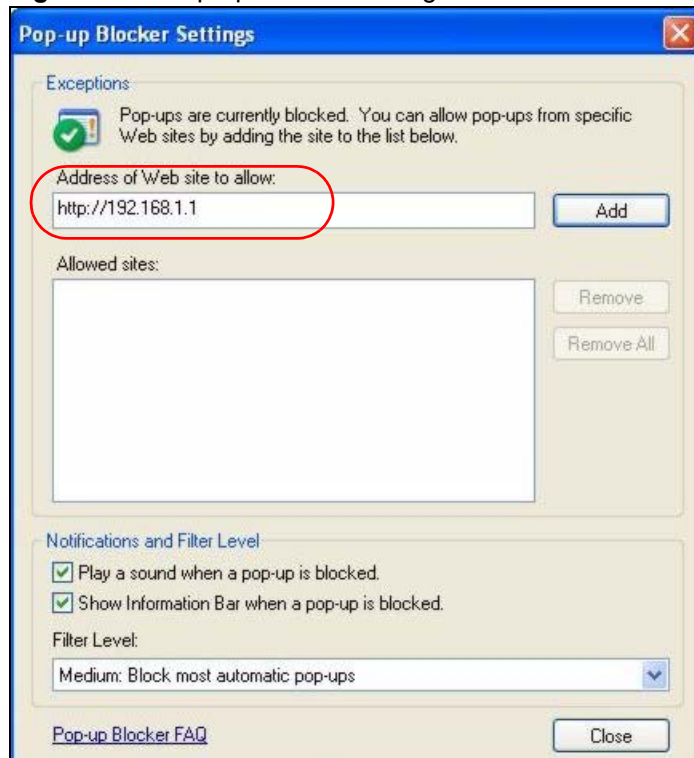
**Figure 131** Pop-up Blocker Settings

- 5 Click **Close** to return to the **Privacy** screen.
- 6 Click **Apply** to save this setting.

## JavaScripts

If pages of the web configurator do not display properly in Internet Explorer, check that JavaScripts are allowed.

- 1 In Internet Explorer, click **Tools, Internet Options** and then the **Security** tab.

**Figure 132** Internet Options: Security

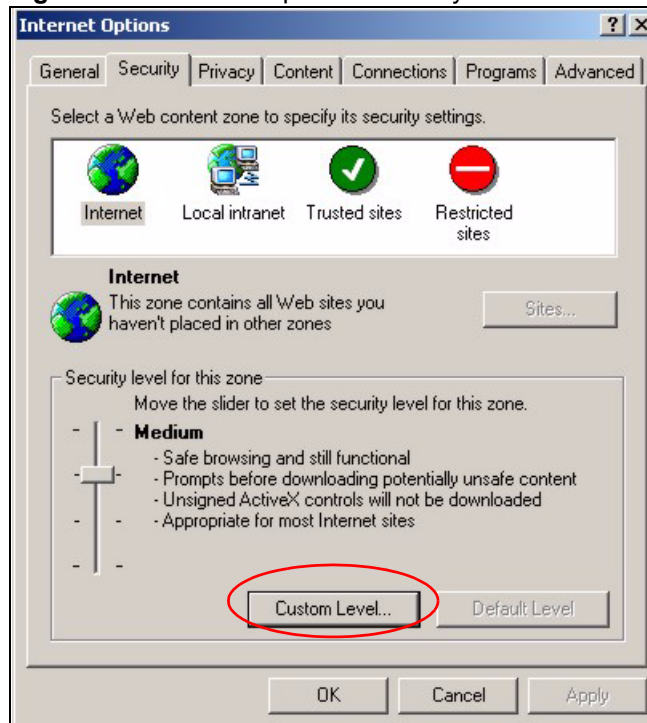

- 2 Click the **Custom Level...** button.
- 3 Scroll down to **Scripting**.
- 4 Under **Active scripting** make sure that **Enable** is selected (the default).
- 5 Under **Scripting of Java applets** make sure that **Enable** is selected (the default).
- 6 Click **OK** to close the window.

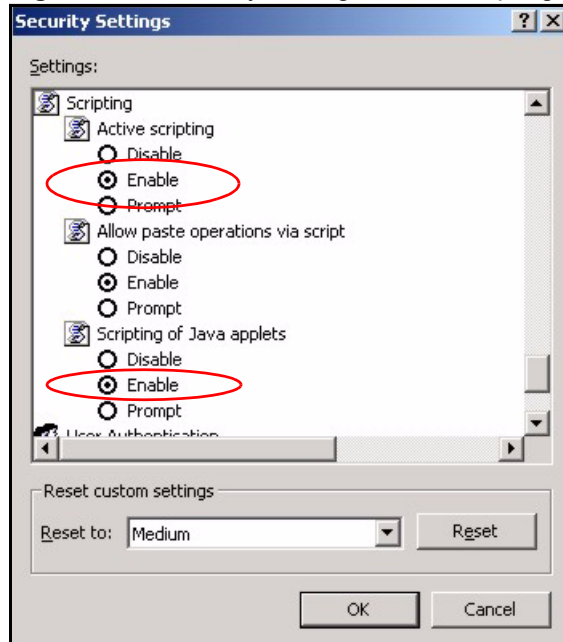
**Figure 133** Security Settings - Java Scripting

## Java Permissions

- 1 From Internet Explorer, click **Tools, Internet Options** and then the **Security** tab.
- 2 Click the **Custom Level...** button.
- 3 Scroll down to **Microsoft VM**.
- 4 Under **Java permissions** make sure that a safety level is selected.
- 5 Click **OK** to close the window.

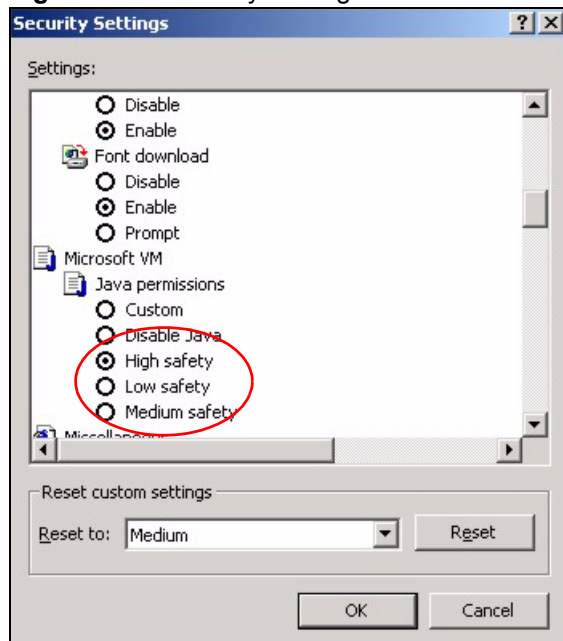
**Figure 134** Security Settings - Java

## JAVA (Sun)

- 1 From Internet Explorer, click **Tools**, **Internet Options** and then the **Advanced** tab.
- 2 Make sure that **Use Java 2 for <applet>** under **Java (Sun)** is selected.
- 3 Click **OK** to close the window.

Figure 135 Java (Sun)

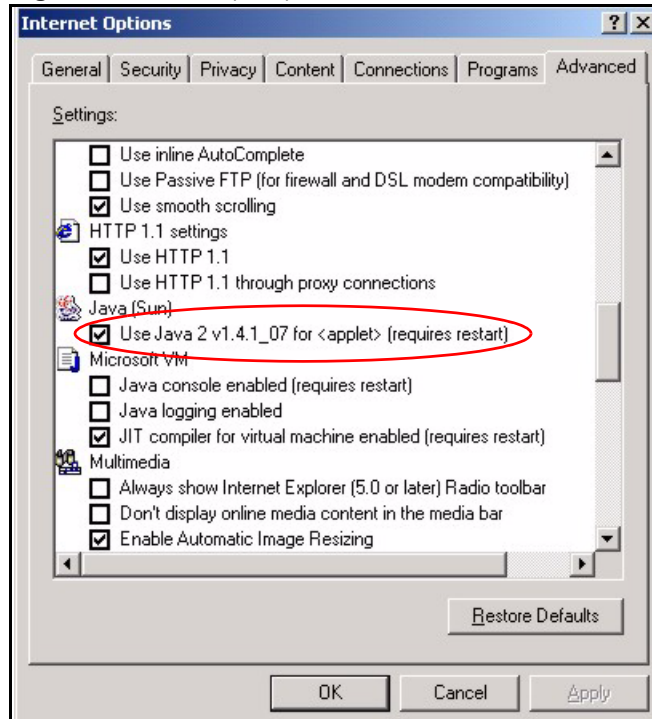

## Mozilla Firefox

Mozilla Firefox 2.0 screens are used here. Screens for other versions may vary.

You can enable Java, JavaScripts and pop-ups in one screen. Click **Tools**, then click **Options** in the screen that appears.

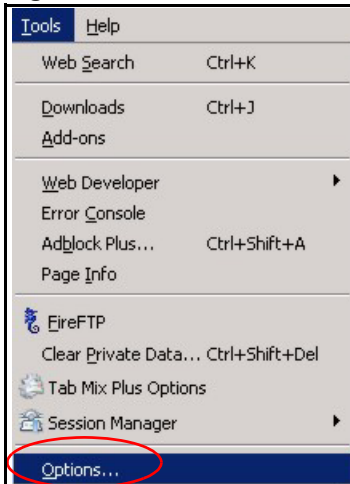
**Figure 136** Mozilla Firefox: Tools > Options

Click **Content** to show the screen below. Select the check boxes as shown in the following screen.

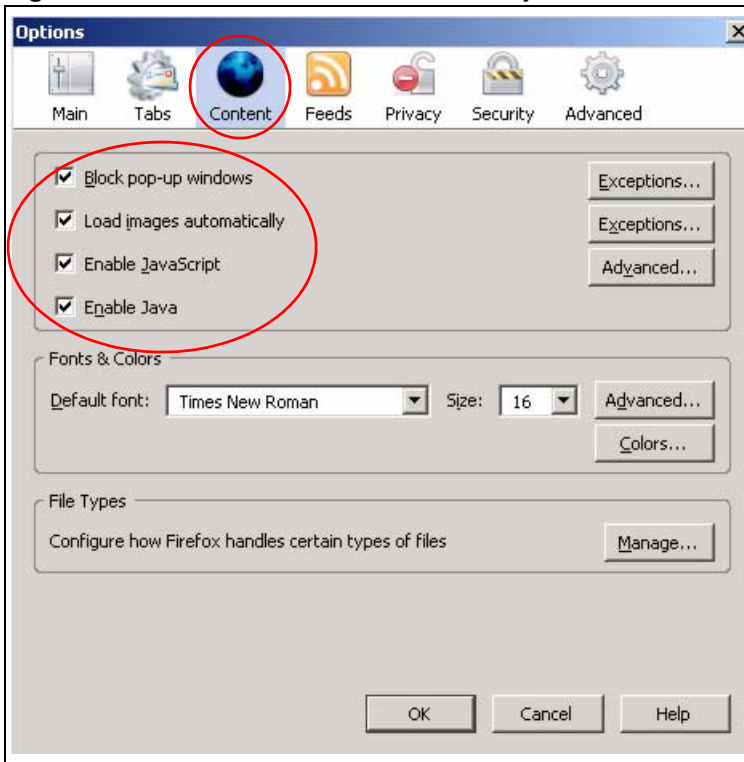
**Figure 137** Mozilla Firefox Content Security





# IP Addresses and Subnetting

This appendix introduces IP addresses and subnet masks.

IP addresses identify individual devices on a network. Every networking device (including computers, servers, routers, printers, etc.) needs an IP address to communicate across the network. These networking devices are also known as hosts.

Subnet masks determine the maximum number of possible hosts on a network. You can also use subnet masks to divide one network into multiple sub-networks.

## Introduction to IP Addresses

One part of the IP address is the network number, and the other part is the host ID. In the same way that houses on a street share a common street name, the hosts on a network share a common network number. Similarly, as each house has its own house number, each host on the network has its own unique identifying number - the host ID. Routers use the network number to send packets to the correct network, while the host ID determines to which host on the network the packets are delivered.

## Structure

An IP address is made up of four parts, written in dotted decimal notation (for example, 192.168.1.1). Each of these four parts is known as an octet. An octet is an eight-digit binary number (for example 11000000, which is 192 in decimal notation).

Therefore, each octet has a possible range of 00000000 to 11111111 in binary, or 0 to 255 in decimal.

The following figure shows an example IP address in which the first three octets (192.168.1) are the network number, and the fourth octet (16) is the host ID.

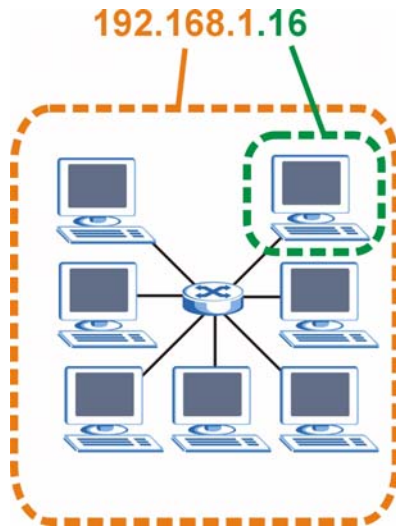
**Figure 138** Network Number and Host ID

How much of the IP address is the network number and how much is the host ID varies according to the subnet mask.

## Subnet Masks

A subnet mask is used to determine which bits are part of the network number, and which bits are part of the host ID (using a logical AND operation). The term “subnet” is short for “sub-network”.

A subnet mask has 32 bits. If a bit in the subnet mask is a “1” then the corresponding bit in the IP address is part of the network number. If a bit in the subnet mask is “0” then the corresponding bit in the IP address is part of the host ID.

The following example shows a subnet mask identifying the network number (in bold text) and host ID of an IP address (192.168.1.2 in decimal).

**Table 93** IP Address Network Number and Host ID Example

	<b>1ST OCTET: (192)</b>	<b>2ND OCTET: (168)</b>	<b>3RD OCTET: (1)</b>	<b>4TH OCTET (2)</b>
IP Address (Binary)	11000000	10101000	00000001	00000010
Subnet Mask (Binary)	<b>11111111</b>	<b>11111111</b>	<b>11111111</b>	00000000
Network Number	<b>11000000</b>	<b>10101000</b>	<b>00000001</b>	
Host ID				00000010

By convention, subnet masks always consist of a continuous sequence of ones beginning from the leftmost bit of the mask, followed by a continuous sequence of zeros, for a total number of 32 bits.

Subnet masks can be referred to by the size of the network number part (the bits with a “1” value). For example, an “8-bit mask” means that the first 8 bits of the mask are ones and the remaining 24 bits are zeroes.

Subnet masks are expressed in dotted decimal notation just like IP addresses. The following examples show the binary and decimal notation for 8-bit, 16-bit, 24-bit and 29-bit subnet masks.

**Table 94** Subnet Masks

	BINARY				DECIMAL
	1ST OCTET	2ND OCTET	3RD OCTET	4TH OCTET	
8-bit mask	11111111	00000000	00000000	00000000	255.0.0.0
16-bit mask	11111111	11111111	00000000	00000000	255.255.0.0
24-bit mask	11111111	11111111	11111111	00000000	255.255.255.0
29-bit mask	11111111	11111111	11111111	11111000	255.255.255.248

## Network Size

The size of the network number determines the maximum number of possible hosts you can have on your network. The larger the number of network number bits, the smaller the number of remaining host ID bits.

An IP address with host IDs of all zeros is the IP address of the network (192.168.1.0 with a 24-bit subnet mask, for example). An IP address with host IDs of all ones is the broadcast address for that network (192.168.1.255 with a 24-bit subnet mask, for example).

As these two IP addresses cannot be used for individual hosts, calculate the maximum number of possible hosts in a network as follows:

**Table 95** Maximum Host Numbers

SUBNET MASK		HOST ID SIZE		MAXIMUM NUMBER OF HOSTS
8 bits	255.0.0.0	24 bits	$2^{24} - 2$	16777214
16 bits	255.255.0.0	16 bits	$2^{16} - 2$	65534
24 bits	255.255.255.0	8 bits	$2^8 - 2$	254
29 bits	255.255.255.248	3 bits	$2^3 - 2$	6

## Notation

Since the mask is always a continuous number of ones beginning from the left, followed by a continuous number of zeros for the remainder of the 32 bit mask, you can simply specify the number of ones instead of writing the value of each octet. This is usually specified by writing a “/” followed by the number of bits in the mask after the address.

For example, 192.1.1.0 /25 is equivalent to saying 192.1.1.0 with subnet mask 255.255.255.128.

The following table shows some possible subnet masks using both notations.

**Table 96** Alternative Subnet Mask Notation

SUBNET MASK	ALTERNATIVE NOTATION	LAST OCTET (BINARY)	LAST OCTET (DECIMAL)
255.255.255.0	/24	0000 0000	0
255.255.255.128	/25	1000 0000	128

**Table 96** Alternative Subnet Mask Notation (continued)

SUBNET MASK	ALTERNATIVE NOTATION	LAST OCTET (BINARY)	LAST OCTET (DECIMAL)
255.255.255.192	/26	1100 0000	192
255.255.255.224	/27	1110 0000	224
255.255.255.240	/28	1111 0000	240
255.255.255.248	/29	1111 1000	248
255.255.255.252	/30	1111 1100	252

## Subnetting

You can use subnetting to divide one network into multiple sub-networks. In the following example a network administrator creates two sub-networks to isolate a group of servers from the rest of the company network for security reasons.

In this example, the company network address is 192.168.1.0. The first three octets of the address (192.168.1) are the network number, and the remaining octet is the host ID, allowing a maximum of  $2^8 - 2$  or 254 possible hosts.

The following figure shows the company network before subnetting.

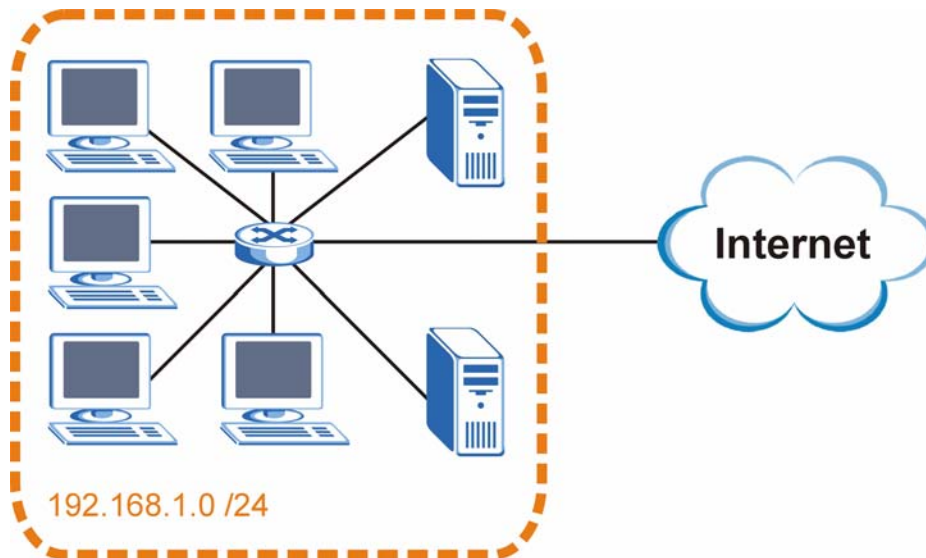
**Figure 139** Subnetting Example: Before Subnetting

You can “borrow” one of the host ID bits to divide the network 192.168.1.0 into two separate sub-networks. The subnet mask is now 25 bits (255.255.255.128 or /25).

The “borrowed” host ID bit can have a value of either 0 or 1, allowing two subnets; 192.168.1.0 /25 and 192.168.1.128 /25.

The following figure shows the company network after subnetting. There are now two sub-networks, **A** and **B**.

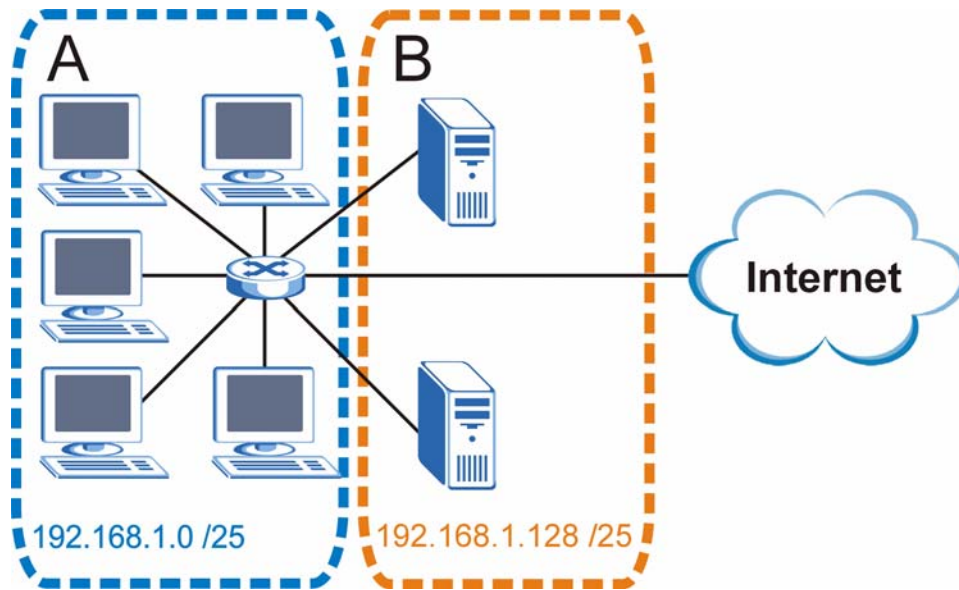
**Figure 140** Subnetting Example: After Subnetting

In a 25-bit subnet the host ID has 7 bits, so each sub-network has a maximum of  $2^7 - 2$  or 126 possible hosts (a host ID of all zeroes is the subnet's address itself, all ones is the subnet's broadcast address).

192.168.1.0 with mask 255.255.255.128 is subnet **A** itself, and 192.168.1.127 with mask 255.255.255.128 is its broadcast address. Therefore, the lowest IP address that can be assigned to an actual host for subnet **A** is 192.168.1.1 and the highest is 192.168.1.126.

Similarly, the host ID range for subnet **B** is 192.168.1.129 to 192.168.1.254.

## Example: Four Subnets

The previous example illustrated using a 25-bit subnet mask to divide a 24-bit address into two subnets. Similarly, to divide a 24-bit address into four subnets, you need to “borrow” two host ID bits to give four possible combinations (00, 01, 10 and 11). The subnet mask is 26 bits (11111111.11111111.11111111.11000000) or 255.255.255.192.

Each subnet contains 6 host ID bits, giving  $2^6 - 2$  or 62 hosts for each subnet (a host ID of all zeroes is the subnet itself, all ones is the subnet's broadcast address).

**Table 97** Subnet 1

IP/SUBNET MASK	NETWORK NUMBER	LAST OCTET BIT VALUE
IP Address (Decimal)	192.168.1.	0
IP Address (Binary)	11000000.10101000.00000001.	00000000
Subnet Mask (Binary)	11111111.11111111.11111111.	11000000
Subnet Address: 192.168.1.0	Lowest Host ID: 192.168.1.1	
Broadcast Address: 192.168.1.63	Highest Host ID: 192.168.1.62	

**Table 98** Subnet 2

IP/SUBNET MASK	NETWORK NUMBER	LAST OCTET BIT VALUE
IP Address	192.168.1.	64
IP Address (Binary)	11000000.10101000.00000001.	01000000
Subnet Mask (Binary)	11111111.11111111.11111111.	11000000
Subnet Address: 192.168.1.64	Lowest Host ID: 192.168.1.65	
Broadcast Address: 192.168.1.127	Highest Host ID: 192.168.1.126	

**Table 99** Subnet 3

IP/SUBNET MASK	NETWORK NUMBER	LAST OCTET BIT VALUE
IP Address	192.168.1.	128
IP Address (Binary)	11000000.10101000.00000001.	10000000
Subnet Mask (Binary)	11111111.11111111.11111111.	11000000
Subnet Address: 192.168.1.128	Lowest Host ID: 192.168.1.129	
Broadcast Address: 192.168.1.191	Highest Host ID: 192.168.1.190	

**Table 100** Subnet 4

IP/SUBNET MASK	NETWORK NUMBER	LAST OCTET BIT VALUE
IP Address	192.168.1.	192
IP Address (Binary)	11000000.10101000.00000001.	11000000
Subnet Mask (Binary)	11111111.11111111.11111111.	11000000
Subnet Address: 192.168.1.192	Lowest Host ID: 192.168.1.193	
Broadcast Address: 192.168.1.255	Highest Host ID: 192.168.1.254	

## Example: Eight Subnets

Similarly, use a 27-bit mask to create eight subnets (000, 001, 010, 011, 100, 101, 110 and 111).

The following table shows IP address last octet values for each subnet.

**Table 101** Eight Subnets

SUBNET	SUBNET ADDRESS	FIRST ADDRESS	LAST ADDRESS	BROADCAST ADDRESS
1	0	1	30	31
2	32	33	62	63
3	64	65	94	95
4	96	97	126	127

**Table 101** Eight Subnets (continued)

SUBNET	SUBNET ADDRESS	FIRST ADDRESS	LAST ADDRESS	BROADCAST ADDRESS
5	128	129	158	159
6	160	161	190	191
7	192	193	222	223
8	224	225	254	255

## Subnet Planning

The following table is a summary for subnet planning on a network with a 24-bit network number.

**Table 102** 24-bit Network Number Subnet Planning

NO. "BORROWED" HOST BITS	SUBNET MASK	NO. SUBNETS	NO. HOSTS PER SUBNET
1	255.255.255.128 (/25)	2	126
2	255.255.255.192 (/26)	4	62
3	255.255.255.224 (/27)	8	30
4	255.255.255.240 (/28)	16	14
5	255.255.255.248 (/29)	32	6
6	255.255.255.252 (/30)	64	2
7	255.255.255.254 (/31)	128	1

The following table is a summary for subnet planning on a network with a 16-bit network number.

**Table 103** 16-bit Network Number Subnet Planning

NO. "BORROWED" HOST BITS	SUBNET MASK	NO. SUBNETS	NO. HOSTS PER SUBNET
1	255.255.128.0 (/17)	2	32766
2	255.255.192.0 (/18)	4	16382
3	255.255.224.0 (/19)	8	8190
4	255.255.240.0 (/20)	16	4094
5	255.255.248.0 (/21)	32	2046
6	255.255.252.0 (/22)	64	1022
7	255.255.254.0 (/23)	128	510
8	255.255.255.0 (/24)	256	254
9	255.255.255.128 (/25)	512	126
10	255.255.255.192 (/26)	1024	62
11	255.255.255.224 (/27)	2048	30
12	255.255.255.240 (/28)	4096	14
13	255.255.255.248 (/29)	8192	6

**Table 103** 16-bit Network Number Subnet Planning (continued)

NO. "BORROWED" HOST BITS	SUBNET MASK	NO. SUBNETS	NO. HOSTS PER SUBNET
14	255.255.255.252 (/30)	16384	2
15	255.255.255.254 (/31)	32768	1

## Configuring IP Addresses

Where you obtain your network number depends on your particular situation. If the ISP or your network administrator assigns you a block of registered IP addresses, follow their instructions in selecting the IP addresses and the subnet mask.

If the ISP did not explicitly give you an IP network number, then most likely you have a single user account and the ISP will assign you a dynamic IP address when the connection is established. If this is the case, it is recommended that you select a network number from 192.168.0.0 to 192.168.255.0. The Internet Assigned Number Authority (IANA) reserved this block of addresses specifically for private use; please do not use any other number unless you are told otherwise. You must also enable Network Address Translation (NAT) on the Switch.

Once you have decided on the network number, pick an IP address for your Switch that is easy to remember (for instance, 192.168.1.1) but make sure that no other device on your network is using that IP address.

The subnet mask specifies the network number portion of an IP address. Your Switch will compute the subnet mask automatically based on the IP address that you entered. You don't need to change the subnet mask computed by the Switch unless you are instructed to do otherwise.

### Private IP Addresses

Every machine on the Internet must have a unique address. If your networks are isolated from the Internet (running only between two branch offices, for example) you can assign any IP addresses to the hosts without problems. However, the Internet Assigned Numbers Authority (IANA) has reserved the following three blocks of IP addresses specifically for private networks:

- 10.0.0.0 — 10.255.255.255
- 172.16.0.0 — 172.31.255.255
- 192.168.0.0 — 192.168.255.255

You can obtain your IP address from the IANA, from an ISP, or it can be assigned from a private network. If you belong to a small organization and your Internet access is through an ISP, the ISP can provide you with the Internet addresses for your local networks. On the other hand, if you are part of a much larger organization, you should consult your network administrator for the appropriate IP addresses.

Regardless of your particular situation, do not create an arbitrary IP address; always follow the guidelines above. For more information on address assignment, please refer to RFC 1597, *Address Allocation for Private Internets* and RFC 1466, *Guidelines for Management of IP Address Space*.



# Legal Information

## Copyright

Copyright © 2007 by ZyXEL Communications Corporation.

The contents of this publication may not be reproduced in any part or as a whole, transcribed, stored in a retrieval system, translated into any language, or transmitted in any form or by any means, electronic, mechanical, magnetic, optical, chemical, photocopying, manual, or otherwise, without the prior written permission of ZyXEL Communications Corporation.

Published by ZyXEL Communications Corporation. All rights reserved.

## Disclaimer

ZyXEL does not assume any liability arising out of the application or use of any products, or software described herein. Neither does it convey any license under its patent rights nor the patent rights of others. ZyXEL further reserves the right to make changes in any products described herein without notice. This publication is subject to change without notice.

## Trademarks

ZyNOS (ZyXEL Network Operating System) is a registered trademark of ZyXEL Communications, Inc. Other trademarks mentioned in this publication are used for identification purposes only and may be properties of their respective owners.

## Certifications

### Federal Communications Commission (FCC) Interference Statement

This device complies with Part 15 of FCC rules. Operation is subject to the following two conditions:

- This device may not cause harmful interference.
- This device must accept any interference received, including interference that may cause undesired operations.

### **FCC Warning**

This device has been tested and found to comply with the limits for a Class A digital switch, pursuant to Part 15 of the FCC Rules. These limits are designed to provide reasonable protection against harmful interference in a commercial environment. This device generates, uses, and can radiate radio frequency energy and, if not installed and used in accordance with the instruction manual, may cause harmful interference to radio communications. Operation of this device in a residential area is likely to cause harmful interference in which case the user will be required to correct the interference at his own expense.

### **CE Mark Warning:**

This is a class A product. In a domestic environment this product may cause radio interference in which case the user may be required to take adequate measures.

### **Taiwanese BSMI (Bureau of Standards, Metrology and Inspection) A Warning:**

警告使用者  
這是甲類的資訊產品，在居住的環境使用時，  
可能造成射頻干擾，在這種情況下，  
使用者會被要求採取某些適當的對策。

### **Notices**

Changes or modifications not expressly approved by the party responsible for compliance could void the user's authority to operate the equipment.

This Class A digital apparatus complies with Canadian ICES-003.

Cet appareil numérique de la classe A est conforme à la norme NMB-003 du Canada.

CLASS 1 LASER PRODUCT

APPAREIL A LASER DE CLASS 1

PRODUCT COMPLIES WITH 21 CFR 1040.10 AND 1040.11.

PRODUIT CONFORME SELON 21 CFR 1040.10 ET 1040.11.

### **Viewing Certifications**

- 1 Go to <http://www.zyxel.com>.
- 2 Select your product on the ZyXEL home page to go to that product's page.
- 3 Select the certification you wish to view from this page.

## **ZyXEL Limited Warranty**

ZyXEL warrants to the original end user (purchaser) that this product is free from any defects in materials or workmanship for a period of up to two years from the date of purchase. During the warranty period, and upon proof of purchase, should the product have indications of failure due to faulty workmanship and/or materials, ZyXEL will, at its discretion, repair or replace the defective products or components without charge for either parts or labor, and to whatever extent it shall deem necessary to restore the product or components to proper operating

condition. Any replacement will consist of a new or re-manufactured functionally equivalent product of equal or higher value, and will be solely at the discretion of ZyXEL. This warranty shall not apply if the product has been modified, misused, tampered with, damaged by an act of God, or subjected to abnormal working conditions.

**Note**

Repair or replacement, as provided under this warranty, is the exclusive remedy of the purchaser. This warranty is in lieu of all other warranties, express or implied, including any implied warranty of merchantability or fitness for a particular use or purpose. ZyXEL shall in no event be held liable for indirect or consequential damages of any kind to the purchaser.

To obtain the services of this warranty, contact ZyXEL's Service Center for your Return Material Authorization number (RMA). Products must be returned Postage Prepaid. It is recommended that the unit be insured when shipped. Any returned products without proof of purchase or those with an out-dated warranty will be repaired or replaced (at the discretion of ZyXEL) and the customer will be billed for parts and labor. All repaired or replaced products will be shipped by ZyXEL to the corresponding return address, Postage Paid. This warranty gives you specific legal rights, and you may also have other rights that vary from country to country.

**Registration**

Register your product online to receive e-mail notices of firmware upgrades and information at [www.zyxel.com](http://www.zyxel.com) for global products, or at [www.us.zyxel.com](http://www.us.zyxel.com) for North American products.



# Customer Support

Please have the following information ready when you contact customer support.

## Required Information

- Product model and serial number.
- Warranty Information.
- Date that you received your device.
- Brief description of the problem and the steps you took to solve it.

“+” is the (prefix) number you dial to make an international telephone call.

## Corporate Headquarters (Worldwide)

- Support E-mail: [support@zyxel.com.tw](mailto:support@zyxel.com.tw)
- Sales E-mail: [sales@zyxel.com.tw](mailto:sales@zyxel.com.tw)
- Telephone: +886-3-578-3942
- Fax: +886-3-578-2439
- Web: [www.zyxel.com](http://www.zyxel.com), [www.europe.zyxel.com](http://www.europe.zyxel.com)
- FTP: [ftp.zyxel.com](ftp://ftp.zyxel.com), [ftp.europe.zyxel.com](ftp://ftp.europe.zyxel.com)
- Regular Mail: ZyXEL Communications Corp., 6 Innovation Road II, Science Park, Hsinchu 300, Taiwan

## Costa Rica

- Support E-mail: [soporte@zyxel.co.cr](mailto:soporte@zyxel.co.cr)
- Sales E-mail: [sales@zyxel.co.cr](mailto:sales@zyxel.co.cr)
- Telephone: +506-2017878
- Fax: +506-2015098
- Web: [www.zyxel.co.cr](http://www.zyxel.co.cr)
- FTP: [ftp.zyxel.co.cr](ftp://ftp.zyxel.co.cr)
- Regular Mail: ZyXEL Costa Rica, Plaza Roble Escazú, Etapa El Patio, Tercer Piso, San José, Costa Rica

## Czech Republic

- E-mail: [info@cz.zyxel.com](mailto:info@cz.zyxel.com)
- Telephone: +420-241-091-350
- Fax: +420-241-091-359
- Web: [www.zyxel.cz](http://www.zyxel.cz)

- Regular Mail: ZyXEL Communications, Czech s.r.o., Modranská 621, 143 01 Praha 4 - Modrany, Česká Republika

### **Denmark**

- Support E-mail: support@zyxel.dk
- Sales E-mail: sales@zyxel.dk
- Telephone: +45-39-55-07-00
- Fax: +45-39-55-07-07
- Web: www.zyxel.dk
- Regular Mail: ZyXEL Communications A/S, Columbusvej, 2860 Soeborg, Denmark

### **Finland**

- Support E-mail: support@zyxel.fi
- Sales E-mail: sales@zyxel.fi
- Telephone: +358-9-4780-8411
- Fax: +358-9-4780-8448
- Web: www.zyxel.fi
- Regular Mail: ZyXEL Communications Oy, Malminkaari 10, 00700 Helsinki, Finland

### **France**

- E-mail: info@zyxel.fr
- Telephone: +33-4-72-52-97-97
- Fax: +33-4-72-52-19-20
- Web: www.zyxel.fr
- Regular Mail: ZyXEL France, 1 rue des Vergers, Bat. 1 / C, 69760 Limonest, France

### **Germany**

- Support E-mail: support@zyxel.de
- Sales E-mail: sales@zyxel.de
- Telephone: +49-2405-6909-69
- Fax: +49-2405-6909-99
- Web: www.zyxel.de
- Regular Mail: ZyXEL Deutschland GmbH., Adenauerstr. 20/A2 D-52146, Wuerselen, Germany

### **Hungary**

- Support E-mail: support@zyxel.hu
- Sales E-mail: info@zyxel.hu
- Telephone: +36-1-3361649
- Fax: +36-1-3259100
- Web: www.zyxel.hu
- Regular Mail: ZyXEL Hungary, 48, Zoldlomb Str., H-1025, Budapest, Hungary

**India**

- Support E-mail: [support@zyxel.in](mailto:support@zyxel.in)
- Sales E-mail: [sales@zyxel.in](mailto:sales@zyxel.in)
- Telephone: +91-11-30888144 to +91-11-30888153
- Fax: +91-11-30888149, +91-11-26810715
- Web: <http://www.zyxel.in>
- Regular Mail: India - ZyXEL Technology India Pvt Ltd., II-Floor, F2/9 Okhla Phase -1, New Delhi 110020, India

**Japan**

- Support E-mail: [support@zyxel.co.jp](mailto:support@zyxel.co.jp)
- Sales E-mail: [zyp@zyxel.co.jp](mailto:zyp@zyxel.co.jp)
- Telephone: +81-3-6847-3700
- Fax: +81-3-6847-3705
- Web: [www.zyxel.co.jp](http://www.zyxel.co.jp)
- Regular Mail: ZyXEL Japan, 3F, Office T&U, 1-10-10 Higashi-Gotanda, Shinagawa-ku, Tokyo 141-0022, Japan

**Kazakhstan**

- Support: <http://zyxel.kz/support>
- Sales E-mail: [sales@zyxel.kz](mailto:sales@zyxel.kz)
- Telephone: +7-3272-590-698
- Fax: +7-3272-590-689
- Web: [www.zyxel.kz](http://www.zyxel.kz)
- Regular Mail: ZyXEL Kazakhstan, 43 Dostyk Ave., Office 414, Dostyk Business Centre, 050010 Almaty, Republic of Kazakhstan

**Malaysia**

- Support E-mail: [support@zyxel.com.my](mailto:support@zyxel.com.my)
- Sales E-mail: [sales@zyxel.com.my](mailto:sales@zyxel.com.my)
- Telephone: +603-8076-9933
- Fax: +603-8076-9833
- Web: <http://www.zyxel.com.my>
- Regular Mail: ZyXEL Malaysia Sdn Bhd., 1-02 & 1-03, Jalan Kenari 17F, Bandar Puchong Jaya, 47100 Puchong, Selangor Darul Ehsan, Malaysia

**North America**

- Support E-mail: [support@zyxel.com](mailto:support@zyxel.com)
- Sales E-mail: [sales@zyxel.com](mailto:sales@zyxel.com)
- Telephone: +1-800-255-4101, +1-714-632-0882
- Fax: +1-714-632-0858
- Web: [www.us.zyxel.com](http://www.us.zyxel.com)
- FTP: <ftp.us.zyxel.com>

- Regular Mail: ZyXEL Communications Inc., 1130 N. Miller St., Anaheim, CA 92806-2001, U.S.A.

### **Norway**

- Support E-mail: [support@zyxel.no](mailto:support@zyxel.no)
- Sales E-mail: [sales@zyxel.no](mailto:sales@zyxel.no)
- Telephone: +47-22-80-61-80
- Fax: +47-22-80-61-81
- Web: [www.zyxel.no](http://www.zyxel.no)
- Regular Mail: ZyXEL Communications A/S, Nils Hansens vei 13, 0667 Oslo, Norway

### **Poland**

- E-mail: [info@pl.zyxel.com](mailto:info@pl.zyxel.com)
- Telephone: +48-22-333 8250
- Fax: +48-22-333 8251
- Web: [www.pl.zyxel.com](http://www.pl.zyxel.com)
- Regular Mail: ZyXEL Communications, ul. Okrzei 1A, 03-715 Warszawa, Poland

### **Russia**

- Support: <http://zyxel.ru/support>
- Sales E-mail: [sales@zyxel.ru](mailto:sales@zyxel.ru)
- Telephone: +7-095-542-89-29
- Fax: +7-095-542-89-25
- Web: [www.zyxel.ru](http://www.zyxel.ru)
- Regular Mail: ZyXEL Russia, Ostrovityanova 37a Str., Moscow 117279, Russia

### **Singapore**

- Support E-mail: [support@zyxel.com.sg](mailto:support@zyxel.com.sg)
- Sales E-mail: [sales@zyxel.com.sg](mailto:sales@zyxel.com.sg)
- Telephone: +65-6899-6678
- Fax: +65-6899-8887
- Web: <http://www.zyxel.com.sg>
- Regular Mail: ZyXEL Singapore Pte Ltd., No. 2 International Business Park, The Strategy #03-28, Singapore 609930

### **Spain**

- Support E-mail: [support@zyxel.es](mailto:support@zyxel.es)
- Sales E-mail: [sales@zyxel.es](mailto:sales@zyxel.es)
- Telephone: +34-902-195-420
- Fax: +34-913-005-345
- Web: [www.zyxel.es](http://www.zyxel.es)
- Regular Mail: ZyXEL Communications, Arte, 21 5ª planta, 28033 Madrid, Spain



**Sweden**

- Support E-mail: support@zyxel.se
- Sales E-mail: sales@zyxel.se
- Telephone: +46-31-744-7700
- Fax: +46-31-744-7701
- Web: www.zyxel.se
- Regular Mail: ZyXEL Communications A/S, Sjöporten 4, 41764 Göteborg, Sweden

**Thailand**

- Support E-mail: support@zyxel.co.th
- Sales E-mail: sales@zyxel.co.th
- Telephone: +662-831-5315
- Fax: +662-831-5395
- Web: <http://www.zyxel.co.th>
- Regular Mail: ZyXEL Thailand Co., Ltd., 1/1 Moo 2, Ratchaphruk Road, Bangrak-Noi, Muang, Nonthaburi 11000, Thailand.

**Ukraine**

- Support E-mail: support@ua.zyxel.com
- Sales E-mail: sales@ua.zyxel.com
- Telephone: +380-44-247-69-78
- Fax: +380-44-494-49-32
- Web: www.ua.zyxel.com
- Regular Mail: ZyXEL Ukraine, 13, Pimonenko Str., Kiev 04050, Ukraine

**United Kingdom**

- Support E-mail: support@zyxel.co.uk
- Sales E-mail: sales@zyxel.co.uk
- Telephone: +44-1344-303044, 08707-555779 (UK only)
- Fax: +44-1344-303034
- Web: www.zyxel.co.uk
- FTP: ftp.zyxel.co.uk
- Regular Mail: ZyXEL Communications UK Ltd., 11 The Courtyard, Eastern Road, Bracknell, Berkshire RG12 2XB, United Kingdom (UK)



# Index

## Numerics

802.1P priority [73](#)

## A

access control  
 limitations [181](#)  
 login account [189](#)  
 remote management [196](#)  
 service port [195](#)  
 SNMP [182](#)

accounting [144](#)

Address Resolution Protocol (ARP) [213](#), [215](#), [216](#)

administrator password [190](#)

age [101](#)

aggregator ID [113](#), [114](#)

aging time [68](#)

ALM LED [41](#)

alternative subnet mask notation [243](#)

applications  
 backbone [29](#)  
 bridging [30](#)  
 IEEE 802.1Q VLAN [31](#)  
 switched workgroup [30](#)

ARP  
 how it works [213](#)  
 viewing [213](#)

ARP (Address Resolution Protocol) [213](#)

authentication  
 and RADIUS [140](#)  
 setup [144](#)

authorization  
 privilege levels [146](#)

auto-crossover [38](#)

automatic VLAN registration [78](#)

## B

back up, configuration file [178](#)

bandwidth control [226](#)

basic settings [63](#)

BPDUs (Bridge Protocol Data Units) [92](#)

Bridge Protocol Data Units (BPDUs) [92](#)

bridging [226](#)

## C

certifications [249](#)  
 notices [250](#)  
 viewing [250](#)

CFI (Canonical Format Indicator) [77](#)

changing the password [50](#)

CIST [95](#)

CIST (Common and Internal Spanning Tree) [93](#)

Class of Service (CoS) [163](#)

cloning a port See port cloning [216](#)

cluster management [205](#)  
 and switch passwords [210](#)  
 cluster manager [205](#), [209](#)  
 cluster member [205](#), [210](#)  
 cluster member firmware upgrade [208](#)  
 network example [205](#)  
 setup [208](#)  
 specification [205](#)  
 status [206](#)  
 switch models [205](#)  
 VID [209](#)  
 web configurator [207](#)

cluster manager [205](#)

cluster member [205](#)

command interface [31](#)

Common and Internal Spanning Tree (CIST) [93](#)

Common and Internal Spanning Tree, See CIST [95](#)

configuration [161](#)  
 change running config [177](#)  
 file names [179](#)

configuration file [51](#)  
 backup [178](#)  
 restore [51](#), [178](#)  
 saving [176](#)

configuration, saving [50](#)

console port  
 settings [40](#)

contact information [253](#)

copying port settings, See port cloning [216](#)

copyright [249](#)

CPU management port [84](#)  
current date [66](#)  
current time [66](#)  
customer support [253](#)

## D

daylight saving time [66](#)  
default IP address [40](#)  
DHCP [167](#)  
    configuration options [167](#)  
    modes [167](#)  
    relay agent [167](#)  
    relay example [172](#)  
    setup [170](#)  
DHCP (Dynamic Host Configuration Protocol) [167](#)  
diagnostics [199](#)  
    Ethernet port test [199](#)  
    ping [199](#)  
    system log [199](#)  
Differentiated Service (DiffServ) [163](#)  
DiffServ [163](#)  
    activate [164](#)  
    DS field [163](#)  
    DSCP [163](#)  
    DSCP-to-IEEE802.1p mapping [164](#)  
    network example [164](#)  
    PHB [163](#)  
dimensions [223](#)  
disclaimer [249](#)  
DS (Differentiated Services) [163](#)  
DSCP  
    DSCP-to-IEEE802.1p mapping [164](#)  
    service level [163](#)  
    what it does [163](#)  
DSCP (DiffServ Code Point) [163](#)  
dynamic link aggregation [111](#)

## E

egress port [87](#)  
Ethernet broadcast address [213](#)  
Ethernet port test [199](#)  
Ethernet ports [38](#)  
    default settings [38](#)  
external authentication server [140](#)

## F

fan speed [64](#)  
FCC interference statement [249](#)  
feature summary [48](#)  
file transfer using FTP  
    command example [179](#)  
filename convention, configuration [179](#)  
filtering database, MAC table [211](#)  
firmware [64](#)  
    upgrade [177](#), [208](#)  
flow control [73](#)  
    back pressure [73](#)  
    IEEE802.3x [73](#)  
forwarding delay [101](#)  
frames  
    tagged [83](#)  
    untagged [83](#)  
front panel [37](#)  
FTP [31](#), [179](#)  
    file transfer procedure [179](#)  
    restrictions over WAN [180](#)

## G

GARP [78](#)  
GARP (Generic Attribute Registration Protocol) [78](#)  
GARP terminology [78](#)  
GARP timer [68](#), [78](#)  
general features [226](#)  
general setup [65](#)  
getting help [52](#)  
GMT (Greenwich Mean Time) [66](#)  
GVRP [78](#), [83](#)  
    and port assignment [83](#)  
GVRP (GARP VLAN Registration Protocol) [78](#)

## H

hardware installation [33](#)  
    mounting [34](#)  
hardware monitor [64](#)  
hardware overview [37](#)  
hello time [101](#)  
hops [101](#)  
HTTPS [192](#)  
    certificates [192](#)

- implementation [192](#)
- public keys, private keys [192](#)
- HTTPS example [193](#)
- humidity [223](#)

**I**

- IANA [248](#)
- IEEE 802.1p, priority [68](#)
- IEEE 802.1x
  - activate [118](#), [142](#), [144](#)
  - reauthentication [119](#)
- IEEE 802.1x, port authentication [117](#)
- IGMP [125](#)
- IGMP (Internet Group Management Protocol) [125](#)
- IGMP filtering [125](#)
  - profile [130](#)
  - profiles [127](#)
- IGMP snooping [125](#)
  - MVR [131](#)
- ingress port [86](#)
- installation
  - freestanding [33](#)
  - precautions [34](#)
  - rack-mounting [34](#)
- Internet Assigned Numbers Authority
  - See IANA [248](#)
- introduction [29](#)
- IP
  - capability [226](#)
  - interface [69](#)
  - services [226](#)
  - setup [69](#)

**L**

- LACP [111](#)
  - system priority [115](#)
  - timeout [115](#)
- layer 2 features [226](#)
- layer 3 features [226](#)
- LEDs [41](#)
  - ALM [41](#)
  - PWR [41](#)
  - SYS [41](#)
- link aggregation [111](#)
  - dynamic [111](#)
  - ID information [112](#)
  - setup [113](#), [114](#)
  - status [112](#)

- Link Aggregation Control Protocol (LACP) [111](#)
- lockout [51](#)
- log [199](#)
- login [45](#)
  - password [50](#)
- login account
  - Administrator [189](#)
  - non-administrator [189](#)
- login accounts [189](#)
  - configuring via web configurator [189](#)
  - multiple [189](#)
  - number of [189](#)
- login password [190](#)
- loop guard [153](#)
  - how it works [154](#)
  - port shut down [155](#)
  - probe packet [154](#)
- loop guard, vs STP [153](#)

**M**

- MAC (Media Access Control) [64](#)
- MAC address [64](#), [213](#)
- MAC address learning [68](#), [89](#)
- MAC table [211](#)
  - how it works [211](#)
  - viewing [212](#)
- maintenance [175](#)
  - configuration backup [178](#)
  - current configuration [175](#)
  - firmware [177](#)
  - main screen [175](#)
  - restoring configuration [178](#)
- Management Information Base (MIB) [182](#)
- management port [40](#), [87](#)
  - default IP address [40](#)
- managing the device
  - good habits [32](#)
  - using FTP. See FTP. [31](#)
  - using SNMP. See SNMP. [31](#)
  - using Telnet. See command interface. [31](#)
  - using the command interface. See command interface. [31](#)
  - using the web configurator. See web configurator. [31](#)
- max
  - age [101](#)
  - hops [101](#)
- MDIX (Media Dependent Interface Crossover) [38](#)
- MGMT port [40](#)
- MIB
  - and SNMP [182](#)

- supported MIBs [183](#)
- MIB (Management Information Base) [182](#)
- mini GBIC ports [39](#)
  - connection speed [39](#)
  - connector type [39](#)
  - transceiver installation [39](#)
  - transceiver removal [39](#)
- mirroring ports [109](#)
- monitor port [109](#)
- mounting brackets [34](#)
- MSA (MultiSource Agreement) [39](#)
- MST Instance, See MSTI [94](#)
- MST region [94](#)
- MSTI [94](#)
  - MST ID [94](#)
- MSTI (Multiple Spanning Tree Instance) [93](#)
- MSTP [91, 93](#)
  - bridge ID [103, 104](#)
  - configuration [99](#)
  - configuration digest [104](#)
  - forwarding delay [101](#)
  - Hello Time [103](#)
  - hello time [101](#)
  - Max Age [104](#)
  - max age [101](#)
  - max hops [101](#)
  - MST region [94](#)
  - network example [93](#)
  - path cost [102](#)
  - port priority [102](#)
  - revision level [101](#)
- MSTP (Multiple Spanning Tree Protocol) [91](#)
- MTU (Multi-Tenant Unit) [67](#)
- multicast [125](#)
  - 802.1 priority [127](#)
  - and IGMP [125](#)
  - IP addresses [125](#)
  - overview [125](#)
  - setup [126, 127](#)
- multicast group [130](#)
- multicast VLAN [134](#)
- Multiple Spanning Tree Instance, See MSTI [93](#)
- Multiple Spanning Tree Protocol, See MSTP. [91](#)
- Multiple STP, see MSTP [93](#)
- MVR [131](#)
  - configuration [132](#)
  - group configuration [134](#)
  - network example [131](#)
- MVR (Multicast VLAN Registration) [131](#)

## N

- NAT [248](#)
- network management system (NMS) [182](#)
- NTP (RFC-1305) [66](#)

## P

- password [50](#)
  - administrator [190](#)
- PHB (Per-Hop Behavior) [163](#)
- ping, test connection [199](#)
- port authentication [117](#)
  - and RADIUS [140](#)
  - IEEE802.1x [118, 142, 144](#)
- port based VLAN type [68](#)
- port cloning [215, 216](#)
  - advanced settings [215, 216](#)
  - basic settings [215, 216](#)
- port details [58](#)
- port isolation [86](#)
- port mirroring [109, 226](#)
  - direction [109](#)
  - egress [109](#)
  - ingress [109](#)
- port redundancy [111](#)
- port security [121](#)
  - MAC address learning [121](#)
  - overview [121](#)
  - setup [121, 155](#)
- port setup [72](#)
- port status [57](#)
- port VLAN trunking [79](#)
- port-based VLAN [84](#)
  - all connected [86](#)
  - port isolation [86](#)
  - settings wizard [86](#)
- ports
  - "standby" [111](#)
  - diagnostics [199](#)
  - mirroring [109](#)
  - speed/duplex [73](#)
- power
  - voltage [65](#)
- power specification [223](#)
- power status [65](#)
- priority level [69](#)
- priority, queue assignment [68](#)
- product registration [251](#)
- PVID [77, 83](#)

PVID (Priority Frame) [77](#)

PWR LED [41](#)

## Q

QoS [226](#)

queue weight [123](#)

queuing [123](#)

  SPQ [123](#)

  WFQ [123](#)

  WRR [123](#)

queuing method [123](#), [124](#)

## R

RADIUS [140](#)

  advantages [140](#)

  and authentication [140](#)

  Network example [139](#)

  server [140](#)

  settings [140](#)

  setup [140](#)

Rapid Spanning Tree Protocol, See RSTP. [91](#)

rear panel connections [41](#)

reboot [177](#)

reboot system [177](#)

registration [251](#)

related documentation [3](#)

remote management [196](#)

  service [197](#)

  trusted computers [196](#)

resetting [51](#), [176](#)

  to factory default settings [176](#)

restoring configuration [51](#), [178](#)

RFC 3164 [201](#)

Round Robin Scheduling [123](#)

routing protocols [226](#)

RSTP [91](#)

rubber feet [33](#)

## S

safety warnings [6](#)

save configuration [50](#), [176](#)

screen summary [48](#)

Secure Shell See SSH

security [226](#)

service access control [195](#)

  service port [196](#)

Simple Network Management Protocol, see SNMP [182](#)

SNMP [31](#), [182](#)

  agent [182](#)

  and MIB [182](#)

  authentication [188](#)

  communities [187](#)

  management model [182](#)

  manager [182](#)

  MIB [183](#)

  network components [182](#)

  object variables [182](#)

  protocol operations [182](#)

  security [188](#)

  setup [186](#)

  traps [188](#)

  version 3 and security [183](#)

  versions supported [182](#)

SNMP traps [183](#)

  supported [183](#), [184](#), [185](#)

Spanning Tree Protocol, See STP. [91](#)

SPQ (Strict Priority Queuing) [123](#)

SSH

  encryption methods [192](#)

  how it works [191](#)

  implementation [192](#)

SSH (Secure Shell) [191](#)

SSL (Secure Socket Layer) [192](#)

standby ports [111](#)

static MAC address [89](#)

static MAC forwarding [89](#)

static routes [161](#)

static trunking example [115](#)

static VLAN

  control [82](#)

  tagging [82](#)

status [46](#), [57](#)

  LED [41](#)

  link aggregation [112](#)

  port [57](#)

  port details [58](#)

  power [65](#)

  STP [98](#), [102](#)

  VLAN [80](#)

STP [91](#), [226](#)

  bridge ID [99](#)

  bridge priority [97](#)

  configuration [96](#), [99](#)

  designated bridge [92](#)

  forwarding delay [98](#)

  Hello BPDU [92](#)

  Hello Time [97](#), [99](#)

  how it works [92](#)

- Max Age [98, 99](#)
- path cost [92, 98](#)
- port priority [98](#)
- port state [92](#)
- root port [92](#)
- status [98, 102](#)
- terminology [91](#)
- vs loop guard [153](#)
- subnet [241](#)
- subnet mask [242](#)
- subnetting [244](#)
- switch lockout [51](#)
- switch reset [51](#)
- switch setup [67](#)
- switching [226](#)
- syntax conventions [4](#)
- SYS LED [41](#)
- syslog [201](#)
  - protocol [201](#)
  - server setup [202](#)
  - settings [201](#)
  - setup [201](#)
  - severity levels [201](#)
- system information [63](#)
- system log [199](#)
- system reboot [177](#)

## T

- TACACS+ [140](#)
  - setup [142](#)
- TACACS+ (Terminal Access Controller Access-Control System Plus) [139](#)
- tagged VLAN [77](#)
- temperature [223](#)
- temperature indicator [64](#)
- time
  - current [66](#)
  - time zone [66](#)
- Time (RFC-868) [66](#)
- time server [66](#)
- time service protocol [66](#)
  - format [66](#)
- trademarks [249](#)
- transceiver
  - installation [39](#)
  - removal [39](#)
- traps
  - destination [187](#)
- trunk group [111](#)
- trunking [111, 226](#)

- example [115](#)
- Tunnel Protocol Attribute, and RADIUS [148](#)
- Type of Service (ToS) [163](#)

## U

- user profiles [139](#)

## V

- Vendor Specific Attribute, See VSA [147](#)
- ventilation holes [33](#)
- VID [77, 80, 81](#)
  - number of possible VIDs [77](#)
  - priority frame [77](#)
- VID (VLAN Identifier) [77](#)
- VLAN [67, 77, 226](#)
  - acceptable frame type [83](#)
  - automatic registration [78](#)
  - ID [77](#)
  - ingress filtering [83](#)
  - introduction [67](#)
  - number of VLANs [80](#)
  - port number [81](#)
  - port settings [82](#)
  - port-based VLAN [84](#)
  - port-based, all connected [86](#)
  - port-based, isolation [86](#)
  - port-based, wizard [86](#)
  - static VLAN [81](#)
  - status [80, 81](#)
  - tagged [77](#)
  - trunking [79, 83](#)
  - type [68, 79](#)
- VLAN (Virtual Local Area Network) [67](#)
- VSA [147](#)

## W

- warranty [250](#)
  - note [251](#)
- web configurator [31, 45](#)
  - getting help [52](#)
  - home [46](#)
  - login [45](#)
  - logout [52](#)
  - navigation panel [47](#)
  - screen summary [48](#)



weight, queuing [123](#)

Weighted Round Robin Scheduling (WRR) [123](#)

WFQ (Weighted Fair Queuing) [123](#)

WRR (Weighted Round Robin Scheduling) [123](#)

## **Z**

ZyNOS (ZyXEL Network Operating System) [179](#)

