



Hewlett Packard
Enterprise

HPE FlexNetwork MSR1000 Routers

Installation Guide

Part number: 5998-7749R
Document version: 6W103-20160205

© Copyright 2016 Hewlett Packard Enterprise Development LP

The information contained herein is subject to change without notice. The only warranties for Hewlett Packard Enterprise products and services are set forth in the express warranty statements accompanying such products and services. Nothing herein should be construed as constituting an additional warranty. Hewlett Packard Enterprise shall not be liable for technical or editorial errors or omissions contained herein.

Confidential computer software. Valid license from Hewlett Packard Enterprise required for possession, use, or copying. Consistent with FAR 12.211 and 12.212, Commercial Computer Software, Computer Software Documentation, and Technical Data for Commercial Items are licensed to the U.S. Government under vendor's standard commercial license.

Links to third-party websites take you outside the Hewlett Packard Enterprise website. Hewlett Packard Enterprise has no control over and is not responsible for information outside the Hewlett Packard Enterprise website.

Acknowledgments

Intel®, Itanium®, Pentium®, Intel Inside®, and the Intel Inside logo are trademarks of Intel Corporation in the United States and other countries.

Microsoft® and Windows® are trademarks of the Microsoft group of companies.

Adobe® and Acrobat® are trademarks of Adobe Systems Incorporated.

Java and Oracle are registered trademarks of Oracle and/or its affiliates.

UNIX® is a registered trademark of The Open Group.

Contents

Preparing for installation	1
Safety recommendations	1
Safety symbols	1
General safety recommendations	1
Electricity safety	1
Examining the installation site	2
Temperature and humidity	2
Cleanliness	2
Cooling system	2
ESD prevention	3
EMI	3
Lightning protection	4
Rack-mounting	4
Installation accessories	4
Installation checklist	5
Installing the router	7
Installation prerequisites	7
Installation flowchart	7
Installing the router	9
Mounting the router on a workbench	9
Installing the router in a rack	9
Grounding the router	12
Grounding the router through the rack	12
Grounding the router with a grounding strip	14
Grounding the router with a grounding conductor buried in the earth ground	15
Installing an interface module	15
Installing a SIC	15
Installing a DSIC	16
Connecting interface cables	17
Attaching a USB device	18
Logging in through the console port	18
Connecting a console cable	18
Setting terminal parameters	19
Connecting an AC power cord	19
Verifying the installation	20
Powering on the router	20
Verifying before power-on	20
Powering on the router	20
Observing boot information	21
Examining the router after power-on	22
Configuring basic settings for the router	23
Replacement procedure	24
Replacing a SIC	24
Replacing a DSIC	24
Troubleshooting	26
Power supply failure	26
System configuration problems	26
No terminal display	26
Garbled terminal display	26
No response from the serial port	27
Restoring the factory settings	27
Scenario 1	27
Scenario 2	27
Scenario 3	27

Reset button usage guidelines	27
Appendix A Chassis views and technical specifications	28
Chassis views	28
MSR1002-4	28
MSR1003-8	29
MSR1003-8S	29
Technical specifications	30
Appendix B LEDs	31
Panel LEDs	31
LED description	32
Appendix C Slot arrangement	33
Document conventions and icons	34
Conventions	34
Network topology icons	35
Support and other resources	36
Accessing Hewlett Packard Enterprise Support	36
Accessing updates	36
Websites	37
Customer self repair	37
Remote support	37
Documentation feedback	37
Index	39

Preparing for installation

The HPE MSR1000 Router Series includes the models in [Table 1](#).

Table 1 HPE MSR1000 Router Series models

Router model	Product code	HPE description	RMN
MSR1002-4	JG875A	HPE MSR1002-4 Router	BJNGA-BB0034
MSR1003-8	JG732A	HPE MSR1003-8 Router	BJNGA-BB0029
MSR1003-8S	JH060A	HPE MSR1003-8S Router	

⚠ **IMPORTANT:**

For regulatory identification purposes, every MSR1000 router is assigned a regulatory model number (RMN). These regulatory model numbers should not be confused with the marketing name HPE MSR100X or the product code.

Safety recommendations

Safety symbols

When reading this document, note the following symbols:

⚠ WARNING means an alert that calls attention to important information that if not understood or followed can result in personal injury.

⚠ CAUTION means an alert that calls attention to important information that if not understood or followed can result in data loss, data corruption, or damage to hardware or software.

General safety recommendations

- Keep the chassis and installation tools away from walk areas.
- Make sure the ground is dry and flat and anti-slip measures are in place.
- Unplug all the external cables (including the power cord) before moving the chassis.

Electricity safety

- Locate the emergency power-off switch in the room before installation. Shut the power off at once in case accident occurs. Disconnect the power cord of the router if necessary.
- Make sure the router is reliably grounded.
- Do not open or close the chassis cover when the router is powered on.
- Correctly connect the interface cables of the router.
- Use an uninterrupted power supply (UPS).
- Do not work alone when the router has power.
- Before installation and replacement, make sure the power has been disconnected.

Examining the installation site

The router must be used indoors. To ensure correct operation and long service life of your router, the installation site must meet the following requirements.

Temperature and humidity

You must maintain a compliant temperature and humidity in the equipment room as described in [Table 2](#).

- Lasting high relative humidity can cause poor insulation, electricity creepage, mechanical property change of materials, and metal corrosion.
- Lasting low relative humidity can cause washer contraction and ESD and introduce problems such as loose captive screws and circuit failure.
- High temperature can accelerate the aging of insulation materials and significantly lower the reliability and lifespan of the switch.

Table 2 Temperature and humidity requirements

Temperature	Humidity
0°C to 45°C (32°F to 113°F)	5% to 90% (noncondensing)

Cleanliness

Dust buildup on the chassis might result in electrostatic adsorption, which causes poor contact of metal components and contact points, especially when indoor relative humidity is low. In the worst case, electrostatic adsorption can cause communication failure.

Table 3 Dust concentration limit in the equipment room

Substance	Concentration limit (particles/m ³)
Dust particles	$\leq 3 \times 10^4$ (No visible dust on desk in three days.)
NOTE: Dust particle diameter $\geq 5 \mu\text{m}$	

The equipment room must also meet limits on salts, acids, and sulfides to eliminate corrosion and premature aging of components, as shown in [Table 4](#).

Table 4 Harmful gas limits in the equipment room

Gas	Max. (mg/m ³)
SO ₂	0.2
H ₂ S	0.006
NH ₃	0.05
Cl ₂	0.01

Cooling system

The MSR1000 router adopts left to right airflow for heat dissipation.

Figure 1 Airflow through the MSR1000 chassis

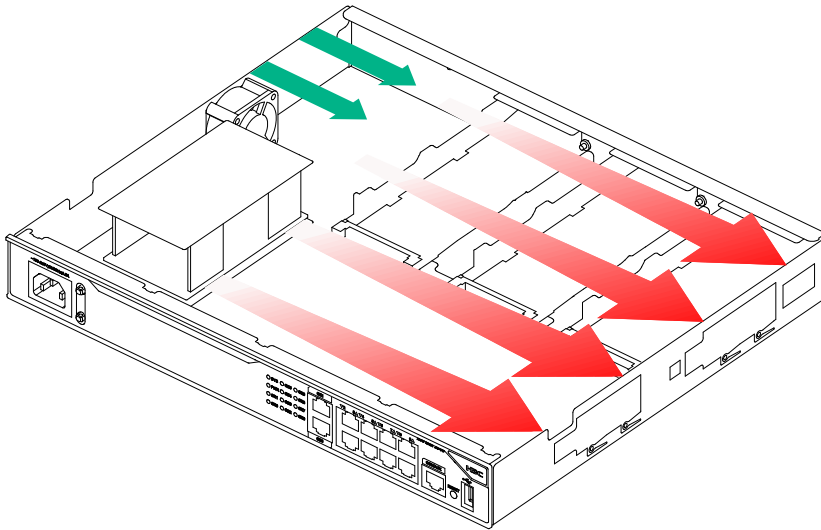

To ensure good ventilation, the following requirements must be met:

- Leave at least 10 cm (3.94 in) of clearance at the air inlet and outlet vents.
- The installation site has a good cooling system.

ESD prevention

⚠ CAUTION:

Check the resistance of the ESD wrist strap for safety. Make sure the resistance reading is in the range of 1 to 10 megohm (Mohm) between human body and the ground.

To prevent electrostatic discharge (ESD), follow these guidelines:

- Make sure the router and the floor are reliably grounded.
- Take dust-proof measures for the equipment room.
- Maintain the humidity and temperature at a compliant level.
- Always wear an ESD wrist strap and ESD cloth when touching a circuit board or transceiver module.
An MSR1000 router does not supply an ESD wrist wrap. Prepare an ESD wrist wrap yourself.
- Place the removed interface module on an antistatic workbench, with the face upward, or put it into an antistatic bag.
- Touch only the edges, instead of electronic components when you observe or move a removed interface module.

To attach an ESD wrist strap:

1. Wear the wrist strap on your wrist.
2. Lock the wrist strap tight around your wrist to keep good contact with the skin.
3. Insert the ESD plug into the ESD socket on the chassis.

EMI

All electromagnetic interference (EMI) sources, from outside or inside of the router and application system, adversely affect the router in the following ways:

- A conduction pattern of capacitance coupling.
- Inductance coupling.
- Electromagnetic wave radiation.
- Common impedance (including the grounding system) coupling.

To prevent EMI, perform the following tasks:

- If AC power is used, use a single-phase three-wire power receptacle with protection earth (PE) to filter interference from the power grid.
- Keep the router far away from radio transmitting stations, radar stations, and high-frequency devices.
- Use electromagnetic shielding, for example, shielded interface cables, when necessary.

Lightning protection

To better protect the MSR1000 router from lightning, perform the following tasks:

- Make sure the grounding cable of the chassis is reliably grounded.
- Make sure the grounding terminal of the AC power receptacle is reliably grounded.
- Install a lightning arrester at the input end of the power supply to enhance the lightning protection capability of the power supply.
- Install a special lightning arrester at the input end of outdoor signal lines (for example, E1/T1 line) to which interface modules of the router are connected to enhance the lightning protection capability.

Rack-mounting

Before mounting the router in a rack, make sure the following requirements are met:

- The rack has a good ventilation system.
- The rack is sturdy enough to support the router and its accessories.
- The rack has enough space to accommodate the router.
- The front and rear of the rack are at least 0.8 m (2.62 ft) away from walls or other devices. Leave enough clearance on both sides of the rack.
- The height of the equipment room is no less than 3 m (9.84 ft).

Installation accessories



Grounding cable (provided)

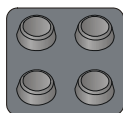

Rubber feet (provided)



Cage nut (user supplied)



Load-bearing screw (provided)



M6 screw (user supplied)



M4 screw (provided)

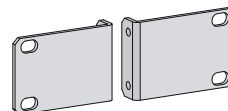

Mounting brackets (provided)

Installation checklist

Table 5 Installation checklist

Item	Requirements	Result	
Installation site	Ventilation	<ul style="list-style-type: none"> There is a minimum clearance of 10 cm (3.94 in) around the inlet and outlet air vents for heat dissipation of the router chassis. A good ventilation system is available at the installation site. 	
	Temperature	0°C to 45°C (32°F to 113°F).	
	Relative humidity	5% to 90% (noncondensing).	
	Cleanness	<ul style="list-style-type: none"> Dust concentration $\leq 3 \times 10^4$ particles/m³. (No visible dust on desk within three days.) 	
	ESD prevention	<ul style="list-style-type: none"> The equipment and floor are reliably grounded. The equipment room is dust-proof. The humidity and temperature are at a compliant level. Wear an ESD wrist strap and uniform when touching a circuit board. Place the removed interface module on an antistatic workbench, with the face upward, or put it into an antistatic bag. Touch only the edges, instead of electronic components when observing or moving a removed interface module. 	
	EMI prevention	<ul style="list-style-type: none"> Take effective measures to reduce interference from the power grid system. Separate the grounding equipment of the router from the grounding or lightning protection grounding equipment of other devices as far as possible. Keep the router far away from radio stations, radar and high-frequency devices working in high current. Use electromagnetic shielding when necessary. 	
	Lightning protection	<ul style="list-style-type: none"> The grounding cable of the chassis is reliably grounded. The grounding terminal of the AC power receptacle is reliably grounded. A port lightning arrester is installed. (Optional.) A power lightning arrester is installed. (Optional.) A signal lightning arrester is installed at the input end of an external signal cable. (Optional.) 	
	Electricity safety	<ul style="list-style-type: none"> Equip an uninterruptible power supply (UPS). The emergency power switch in the equipment room is located. 	
	Workbench	<ul style="list-style-type: none"> The workbench is stable enough. The workbench is reliably grounded. 	

Item		Requirements	Result
	Rack-mounting requirements	<ul style="list-style-type: none"> • The rack has a good ventilation system. • The rack is sturdy enough to support the weight of the router and installation accessories. • The size of the rack is appropriate for the router. • The front and rear of the rack are at least 0.8 m (2.62 ft) away from walls or other devices. 	
Safety precautions	<ul style="list-style-type: none"> • The router is far away from any moist area and heat source. • The emergency power switch in the equipment room is located. 		
Installation tools and accessories	<ul style="list-style-type: none"> • Installation accessories supplied with the router. • User supplied tools. 		
Reference	<ul style="list-style-type: none"> • Documents shipped with the router. • Online documents. 		

Installing the router



WARNING!

To avoid injury, do not touch bare wires, terminals, or parts with high-voltage hazard signs.



IMPORTANT:

- The barcode on the router chassis contains product information that must be provided to local sales agent before you return a faulty router for service.
 - Keep the tamper-proof seal on a mounting screw on the chassis cover intact, and if you want to open the chassis, contact Hewlett Packard Enterprise for permission. Otherwise, Hewlett Packard Enterprise shall not be liable for any consequence.
-

Installation prerequisites

- You have read "Preparing for installation" carefully.
- All requirements in "Preparing for installation" are met.

Installation flowchart

You can install the router on a workbench or on a rack. Select an installation method according to the installation environment, and follow the installation flowchart shown in [Figure 2](#).

Figure 2 Installation flow

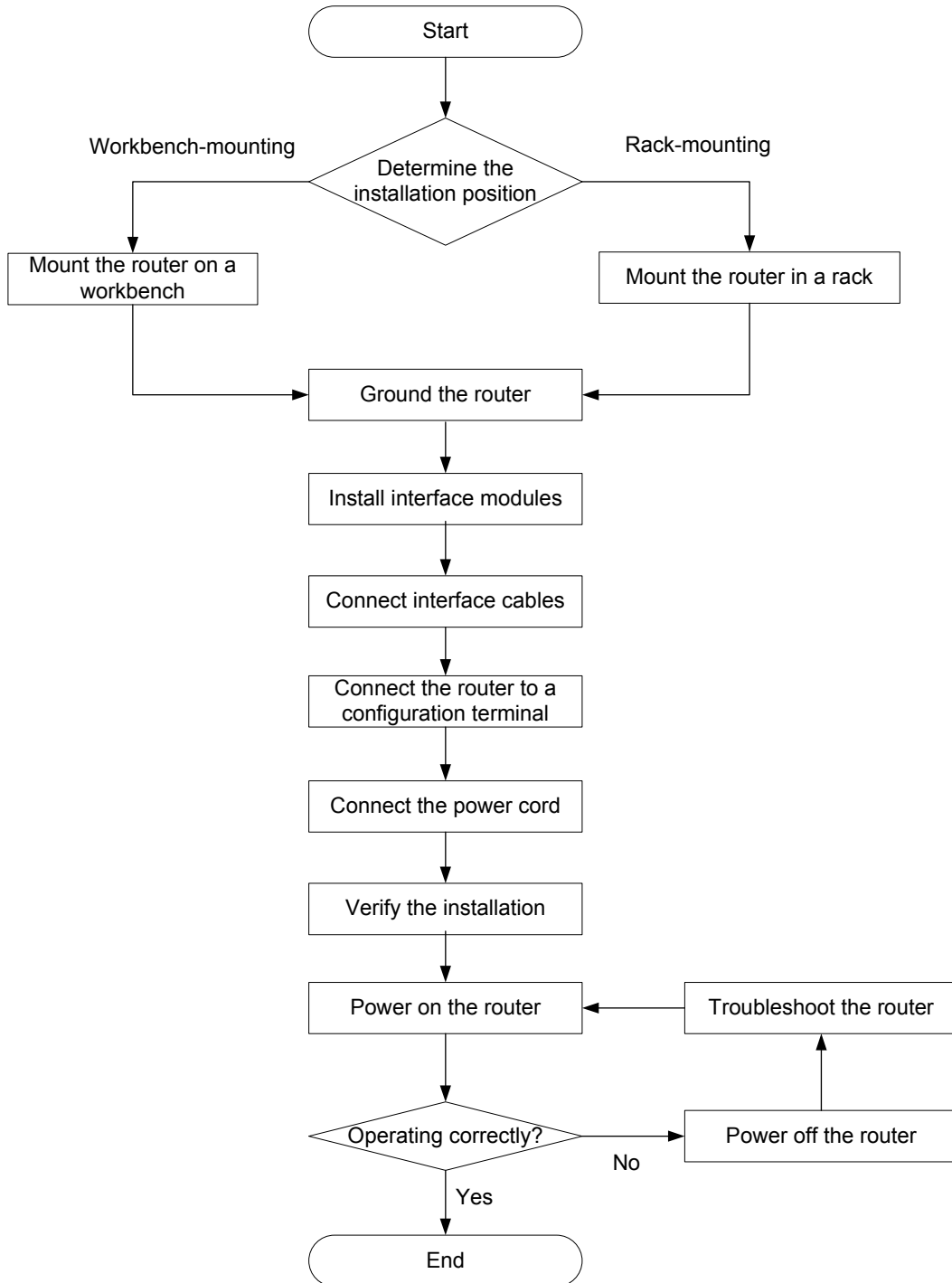

Installing the router

Mounting the router on a workbench

! **IMPORTANT:**

- Allow 10 cm (3.94 in) of clearance around the chassis for heat dissipation.
 - Do not place heavy objects on the router.
-

To mount the router on a workbench:

1. Make sure the workbench is clean, stable, and reliably grounded.
2. Place the router upside down on the workbench and attach the rubber feet to the four round holes in the chassis bottom.

Figure 3 Attaching the rubber feet

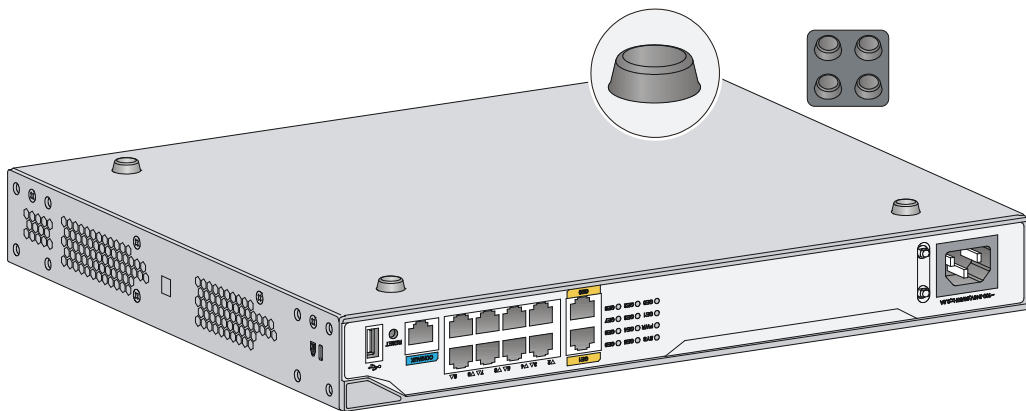

3. Place the router on the workbench with the upside up.

Figure 4 Mounting the router on a workbench

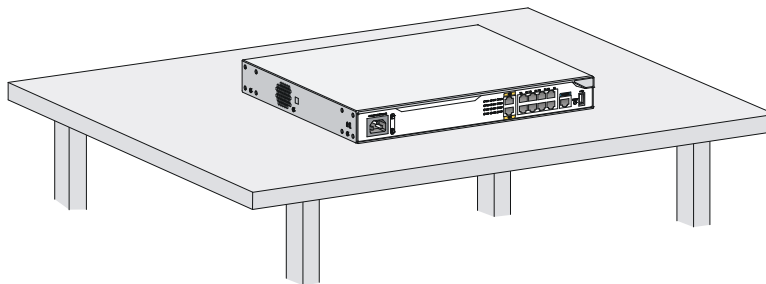

Installing the router in a rack

⚠ **WARNING!**

The mounting brackets can only support the weight of the router. To avoid damage to the router, do not place any objects on the router.

To install the router in a rack:

1. Use a mounting bracket to mark the positions of cage nuts on the front rack posts, making sure the cage nuts on the two front rack posts are at the same level.

Figure 5 Marking the positions of cage nuts

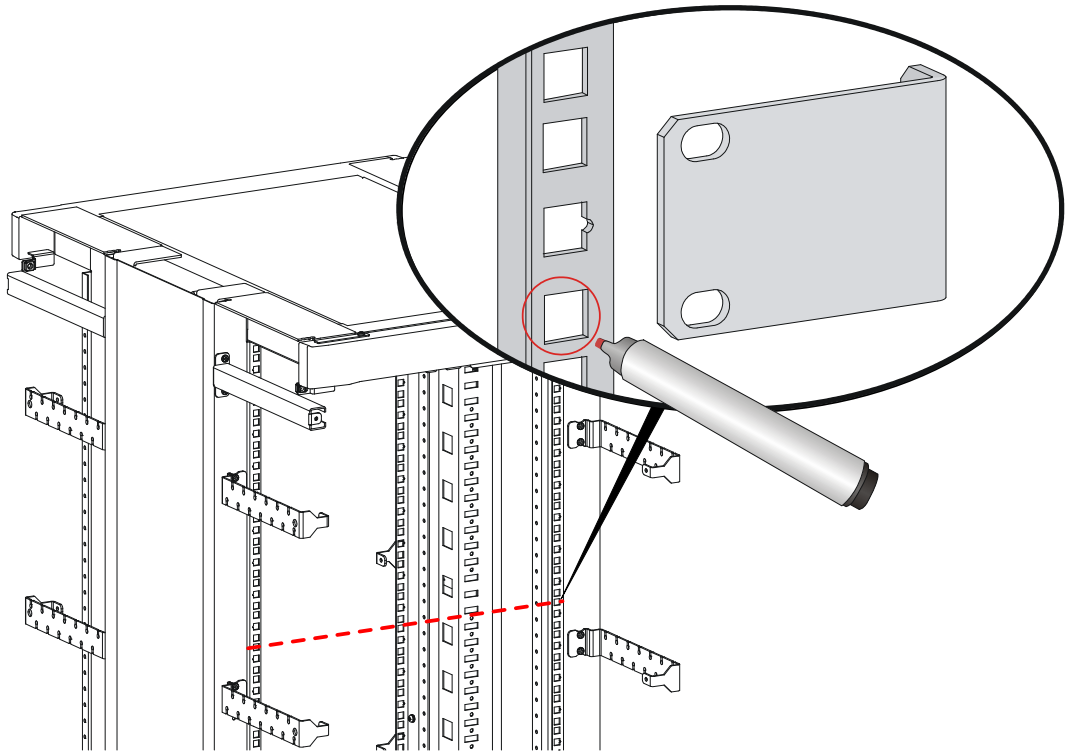

2. Insert one edge of a cage nut into the hole. Use a flat-blade screwdriver to compress the other edge of the cage nut, and then push the cage nut fully into the hole.
3. Repeat step 3 to install other cage nuts to all the marked positions on the front rack posts.

Figure 6 Installing cage nuts

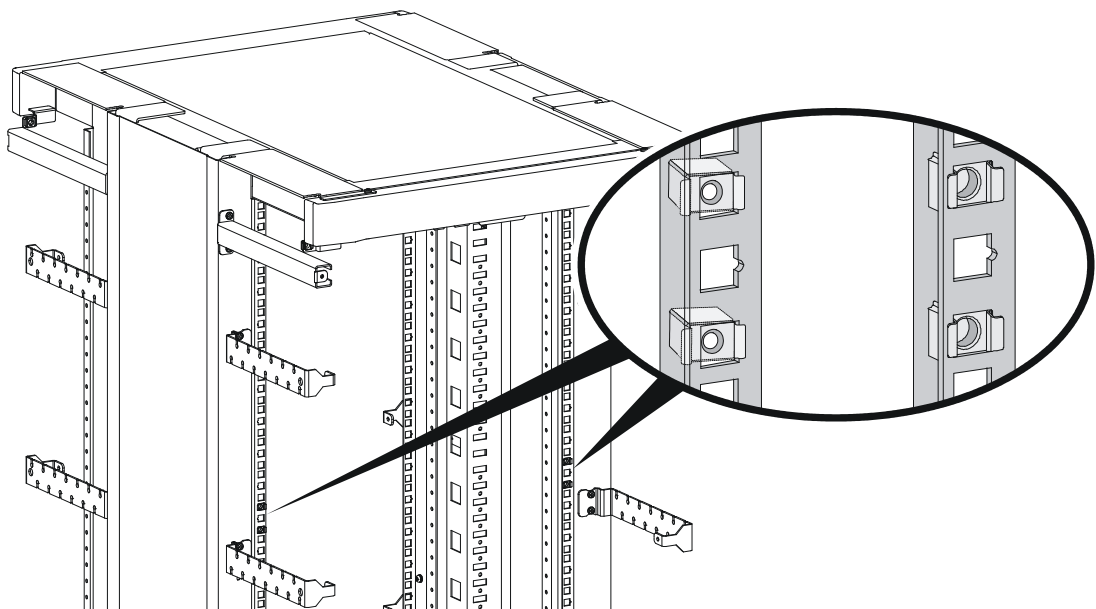

4. Attach the mounting brackets to the two sides of the chassis and fasten the screws.

Figure 7 Attaching the mounting brackets

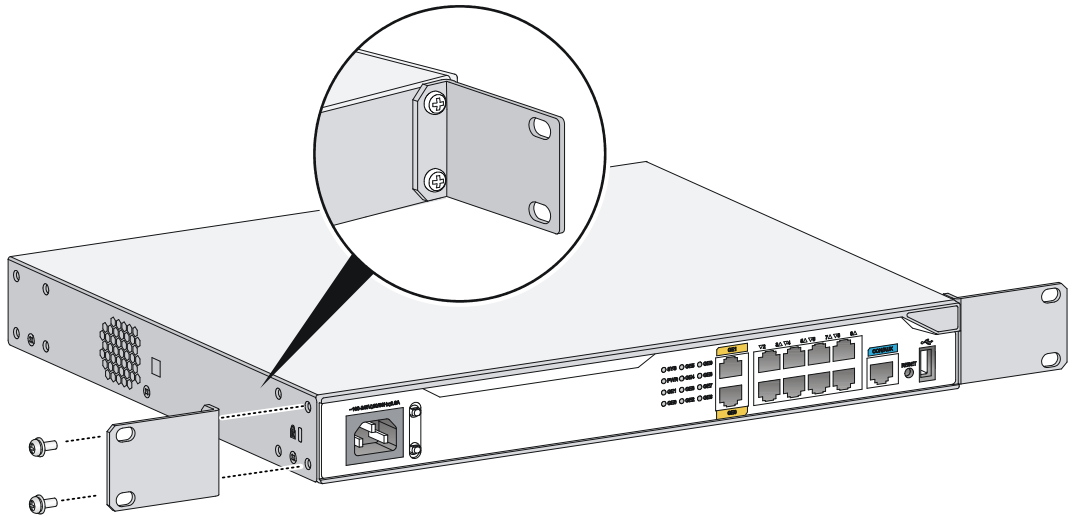

5. Place the chassis on the rack and use M6 screws to attach the mounting brackets to the rack posts.

Figure 8 Securing the router to the rack

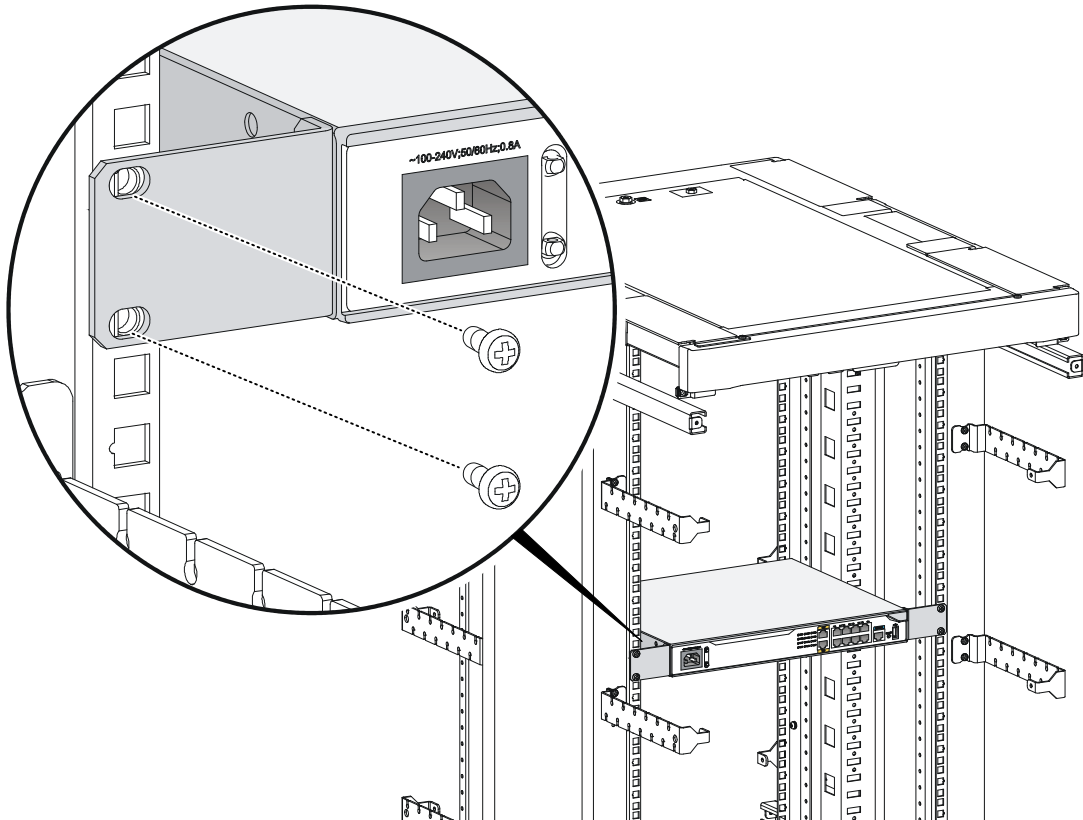

Grounding the router

⚠ WARNING!

Correctly connecting the router grounding cable is crucial to lightning protection and EMI protection.

⚠ IMPORTANT:

The resistance reading should be smaller than 5 ohms between the chassis and the ground.

Grounding the router through the rack

⚠ IMPORTANT:

Make sure the rack is reliably grounded before grounding the router.

To connect the grounding cable:

1. Remove the grounding screw from the grounding hole at the rear of the chassis.
2. Use the grounding screw to attach the ring terminal of the grounding cable to the chassis. See [Figure 9](#).
3. Remove the hex nut from a grounding post on the rack's grounding bar.
4. Use needle-nose pliers to bend a hook at the other end of the grounding cable, attach it to the grounding post, and reinstall the hex nut. See [Figure 9](#).

Figure 9 Grounding the router through the rack (1)

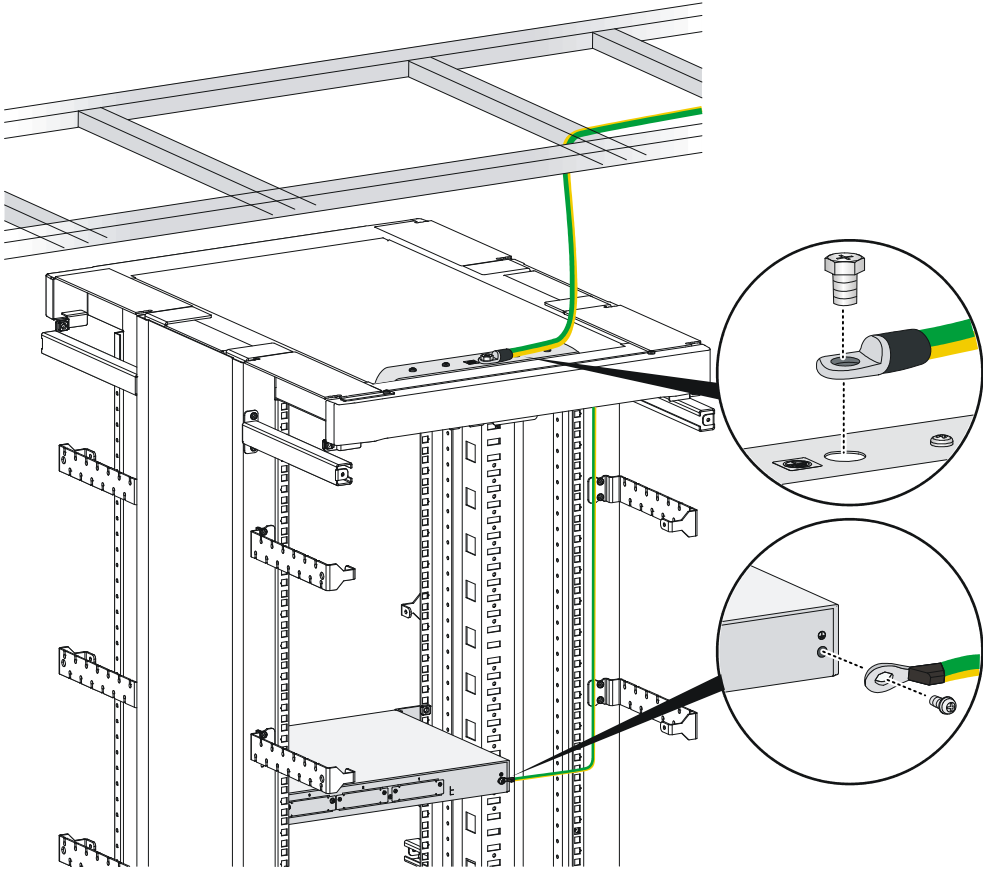
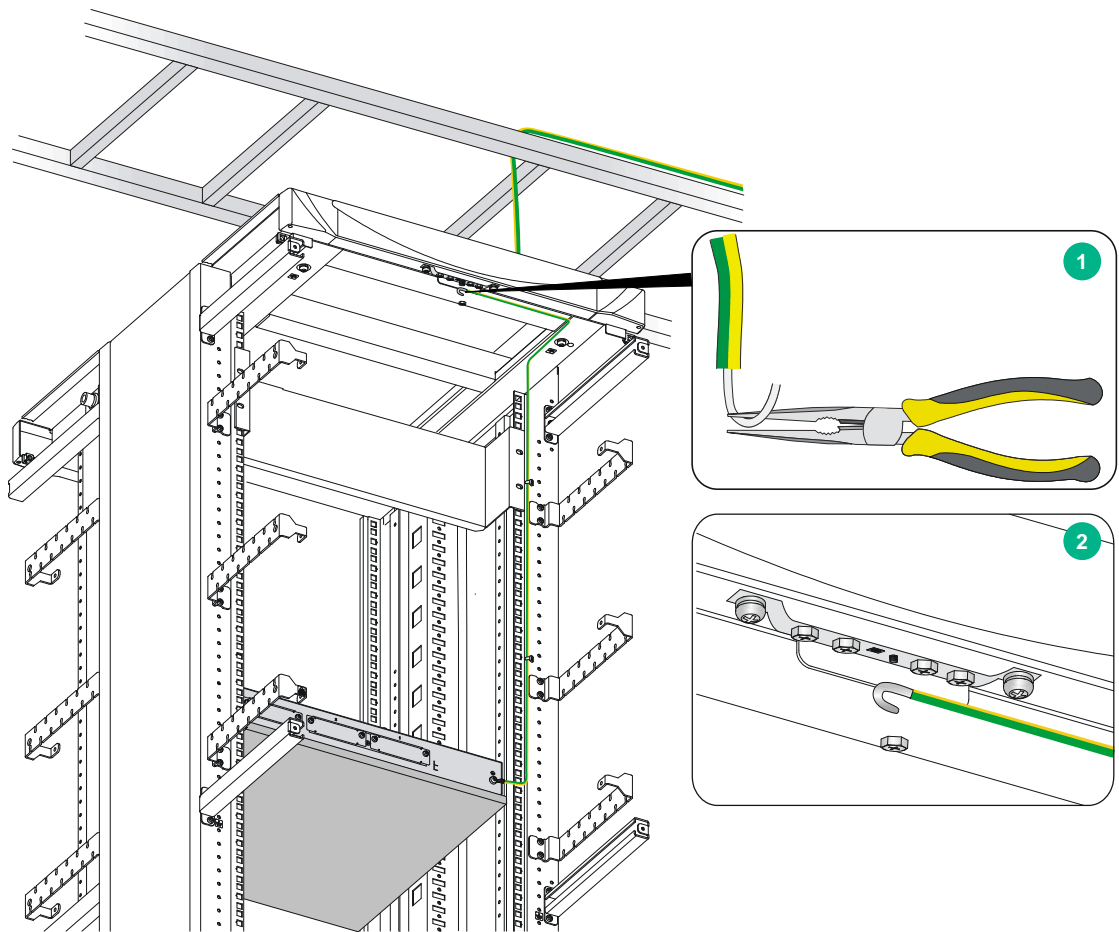

Figure 10 Grounding the router through the rack (2)



Grounding the router with a grounding strip

If a grounding strip is available at the installation site, connect the grounding cable to the grounding strip.

Follow the same procedures in "[Grounding the router through the rack](#)" to connect the grounding cable.

Figure 11 Grounding the router with a grounding strip

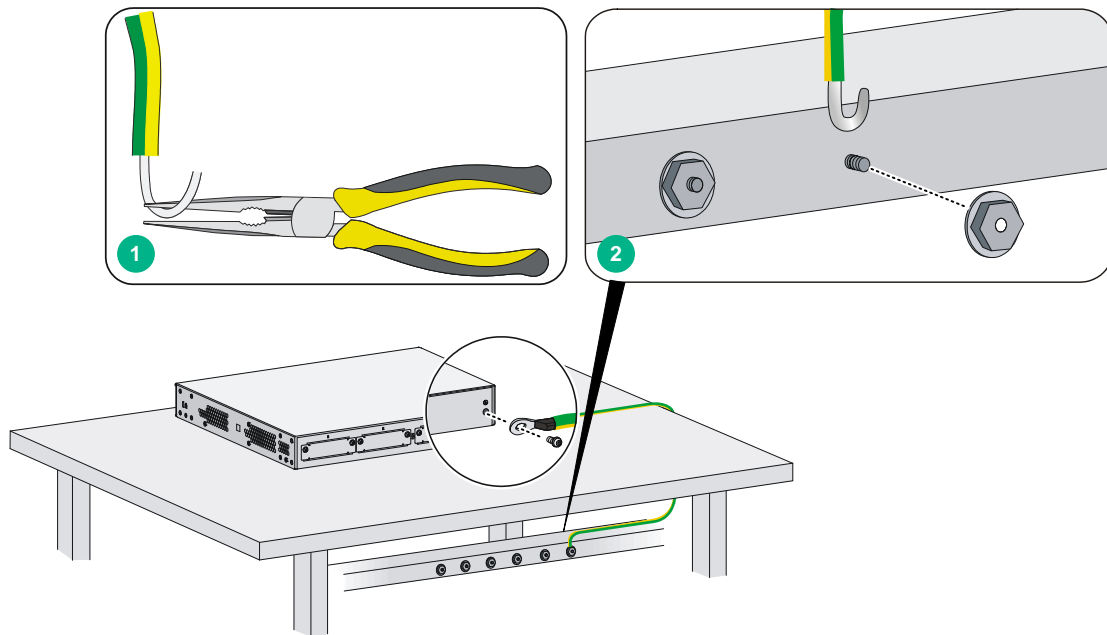

Grounding the router with a grounding conductor buried in the earth ground

If the installation site has no grounding strips, but earth ground is available, hammer a 0.5 m (1.64 ft) or longer angle iron or steel tube into the earth ground to serve as a grounding conductor. The steel tube must be zinc-coated. Weld the yellow-green grounding cable to the angle iron or steel tube and treat the joint for corrosion protection.

Installing an interface module

Installing a SIC

△ CAUTION:

SICs are not hot swappable. Make sure the router is powered off before installing a SIC.

To install a SIC:

1. Remove the fastening screws on the filler panel with a Phillips screwdriver and remove the filler panel.
Keep the removed filler panel for future use.
2. Push the SIC slowly along the slide rails into the slot until it makes close contact with the backplane of the router.
3. Use a Phillips screwdriver to fasten the captive screws on the SIC.

Figure 12 Removing the filler panel

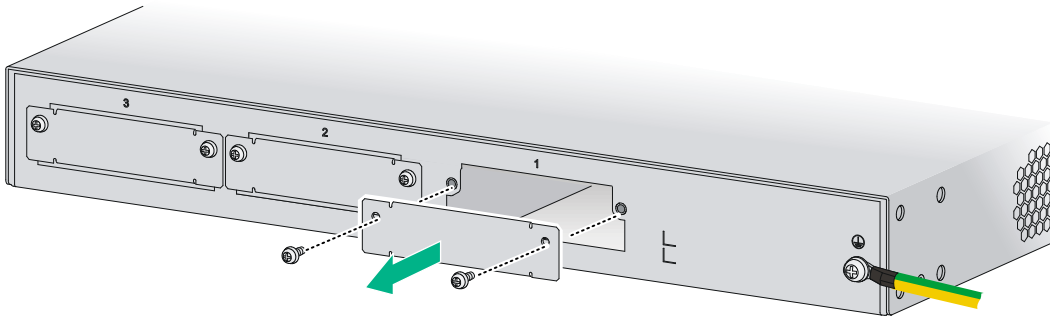
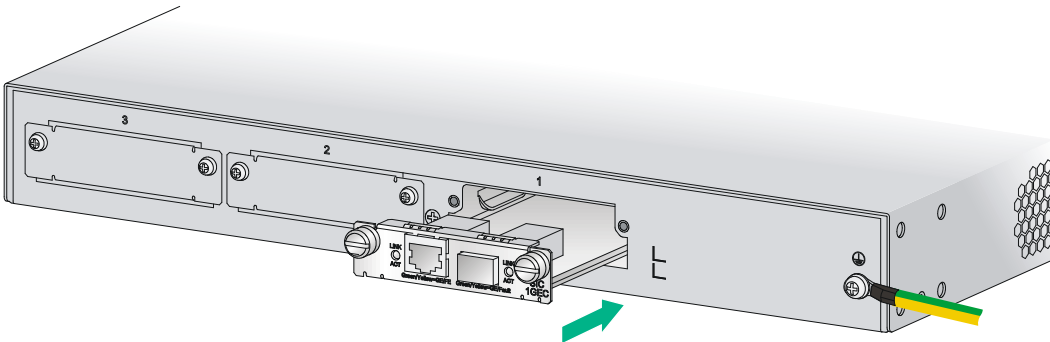

Figure 13 Installing the SIC



Installing a DSIC

⚠ CAUTION:

DSICs are not hot swappable. Make sure the router is powered off before installing a DSIC.

The MSR1002-4 router does not support DSICs.

To install a DSIC:

1. Remove the screws on the filler panel on slot 1 and slot 2 of the router to remove the filler panel, as shown in [Figure 14](#).
2. Loosen the captive screws on the slot divider and pull out the slot divider, as shown in [Figure 15](#).

Figure 14 Removing the filler panel

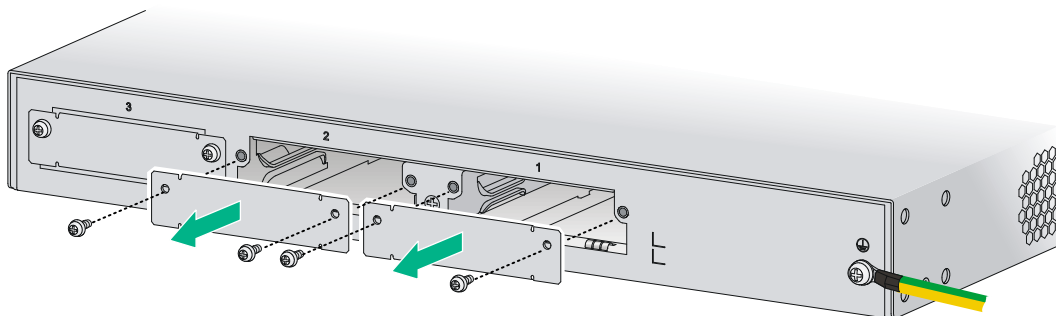
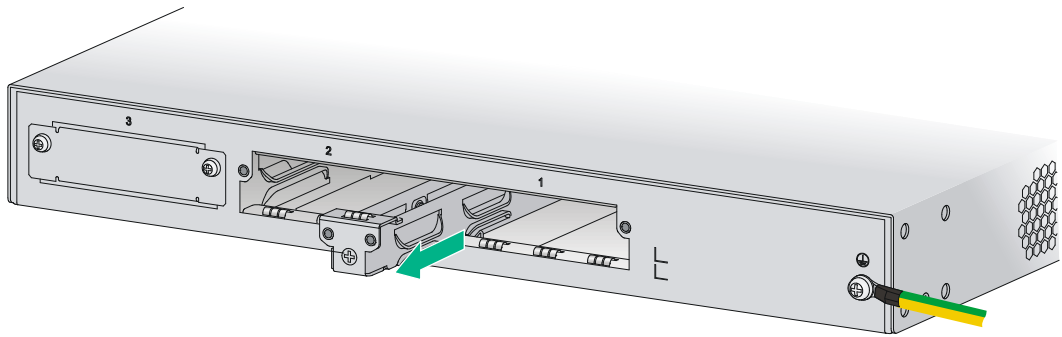
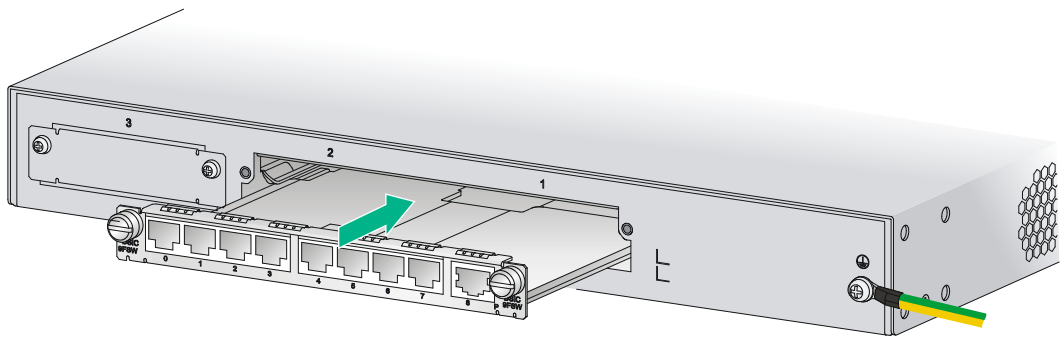

Figure 15 Removing the slot divider



3. Insert the DSIC into the slot and push it along the slide rails until it makes close contact with the backplane of the router.

Figure 16 Installing a DSIC



4. Fasten the captive screws to secure the DSIC.

Connecting interface cables

Connect interface cables before powering on the router. This section describes how to connect Ethernet cables. For other cable connection methods, see *HPE MSR Series Routers Interface Module User Guide*.

To connect an Ethernet cable:

1. Plug one end of an Ethernet cable into the Ethernet port on the router.
2. Plug the other end of the cable into the Ethernet port of the peer device.

Figure 17 Connecting the router to a PC

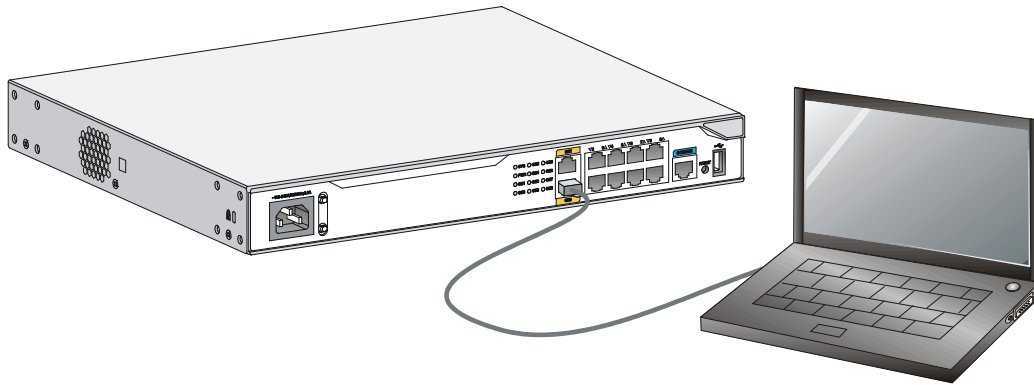

Attaching a USB device

⚠ CAUTION:

- Attach only HPE-certified USB devices.
- To avoid data loss and hardware damage, do not remove a USB device when it is transmitting data.
- The USB port does not support hot-swapping of Sierra Wireless's USB modems.

To attach a USB device:

1. Remove the protective cap from the USB device.
2. Correctly orient the USB device and plug the connector of the USB device to the USB port.

Figure 18 Attaching a USB device

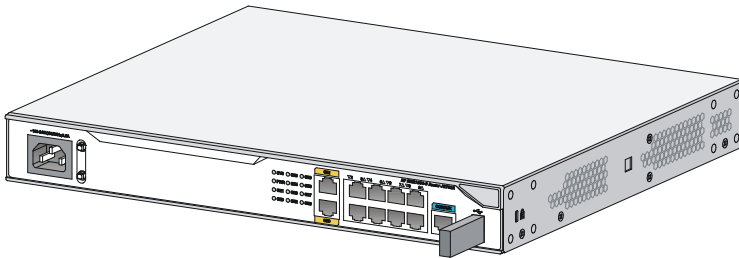

Logging in through the console port

Connecting a console cable

⚠ IMPORTANT:

When you connect a PC to a powered-on router, connect the RJ-45 connector to the router after connecting the DB-9 connector of the console cable to the PC.

To connect a console cable:

1. Plug the DB-9 female connector to the serial port of the configuration terminal.
2. Connect the RJ-45 connector to the console port of the router.

Figure 19 Connecting the console cable

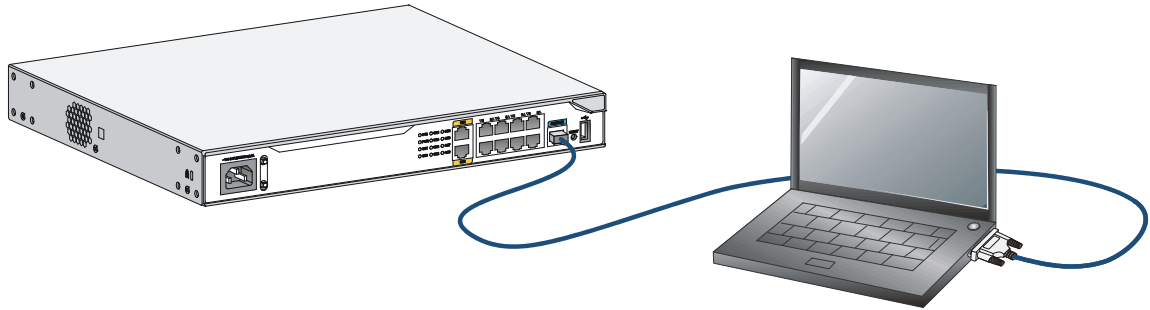

Setting terminal parameters

To access the device through the console port, you must run a terminal emulator program (HyperTerminal, PuTTY, or Tera Term) on the configuration terminal. For information about using a terminal emulator program, see the program's user guide.

The following are the required terminal settings:

- **Baud rate**—9600.
- **Data bits**—8.
- **Stop bits**—1.
- **Parity**—none.
- **Flow control**—none.

Connecting an AC power cord

1. Make sure the router is reliably grounded, and the power switch on the router is in the OFF position.
2. Connect one end of the AC power cord to the AC receptacle on the router, and the other end to the AC power source.
3. Install the bail latch and push it leftward to secure the power cord.

Figure 20 Connecting an AC power cord to the router

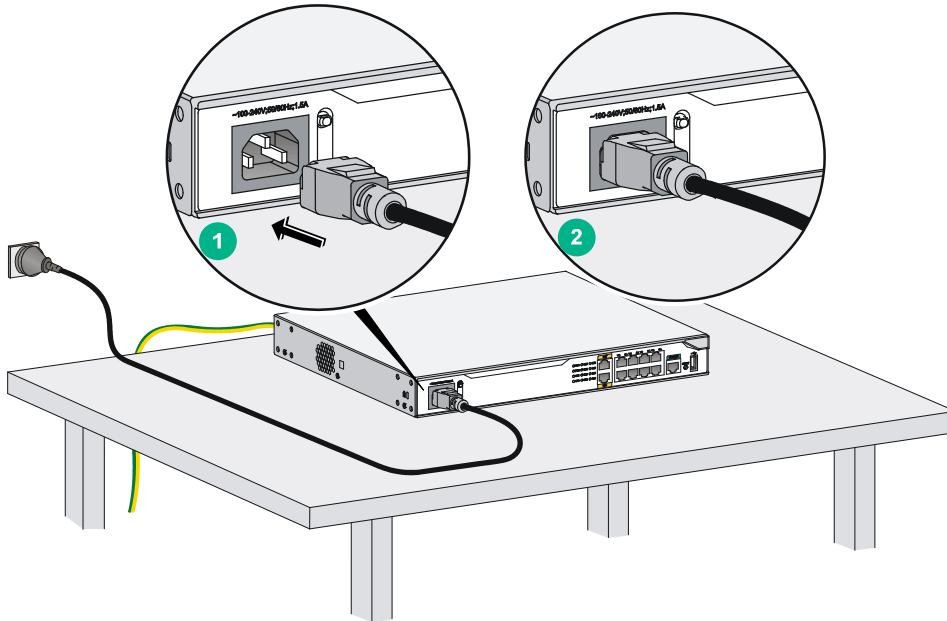

Verifying the installation

After you complete the installation, verify that:

- There is enough space for heat dissipation around the router, and the rack or workbench is stable.
- Interface modules are correctly installed.
- The router, rack, and power cord are reliably grounded.
- The correct power source is used.

Powering on the router

Verifying before power-on

Before powering on the router, verify the following items:

- The power modules are correctly installed.
- The power cord and grounding cable are correctly connected.
- The power source voltage meets the requirement of the router.
- The console cable is correctly connected, the terminal or PC used for configuration has started, and the configuration parameters have been set.
- If a CF card is used, verify that the CF card is in position.
- Make sure the installed interface modules are in position.

Powering on the router

1. Turn on the switch of the power supply system for the router.
2. Turn on the switch of the AC or DC power modules.

Observing boot information

Power on the router, and you can see the following information:

```
System is starting...
Press Ctrl+D to access BASIC-BOOTWARE MENU...
Booting Normal Extended BootWare
The Extended BootWare is self-decompressing...Done.

*****
*
*          HPE MSR1003-8S BootWare, Version 2.30          *
*
*****
Copyright (c) 2010-2015 Hewlett Packard Enterprise Development LP

Compiled Date       : Sep 11 2014
CPU ID             : 0x8
CPU L1 Cache       : 32KB
CPU L2 Cache       : 256KB
Memory Type        : DDR3 SDRAM
Memory Size        : 1024MB
Memory Speed       : 400MHz
Flash Size         : 256MB
CPLD Version       : 1.0
PCB Version        : 2.0

BootWare Validating...
Press Ctrl+B to access EXTENDED-BOOTWARE MENU...
Loading the main image files...
Loading file flash:/msr100x-cmw710-system-e030206.bin.....
.....Done.
Loading file flash:/msr100x-cmw710-security-e030206.bin...Done.
Loading file flash:/msr100x-cmw710-voice-e030206.bin...Done.
Loading file flash:/msr100x-cmw710-data-e030206.bin.....Done.
Loading file flash:/msr100x-cmw710-boot-e030206.bin.....Done.

Image file flash:/msr100x-cmw710-boot-e030206.bin is self-decompressing.....
....Done.
System image is starting...
Cryptographic Algorithms Known-Answer Tests are running ...
CPU 0 of slot 0 in chassis 0:
Starting Known-Answer tests in the user space.
Known-answer test for SHA1 passed.
Known-answer test for SHA224 passed.
Known-answer test for SHA256 passed.
Known-answer test for SHA384 passed.
Known-answer test for SHA512 passed.
```

```

Known-answer test for HMAC-SHA1 passed.
Known-answer test for HMAC-SHA224 passed.
Known-answer test for HMAC-SHA256 passed.
Known-answer test for HMAC-SHA384 passed.
Known-answer test for HMAC-SHA512 passed.
Known-answer test for AES passed.
Known-answer test for RSA(signature/verification) passed.
Known-answer test for RSA(encrypt/decrypt) passed.
Known-answer test for DSA(signature/verification) passed.
Known-answer test for random number generator passed.
Known-Answer tests in the user space passed.
Starting Known-Answer tests in the kernel.
Known-answer test for SHA1 passed.
Known-answer test for HMAC-SHA1 passed.
Known-answer test for AES passed.
Known-answer test for random number generator passed.
Known-Answer tests in the kernel passed.
Starting Known-Answer tests in the engine.
Known-answer test for SHA1 passed.
Known-answer test for HMAC-SHA1 passed.
Known-answer test for AES passed.
Known-answer test for RSA(signature/verification) passed.
Known-answer test for RSA(encrypt/decrypt) passed.
Known-answer test for DSA(signature/verification) passed.
Known-answer test for random number generator passed.
Known-Answer tests in the engine passed.
Cryptographic Algorithms Known-Answer Tests passed.
Line aux0 is available.

```

Press ENTER to get started.

Press **Enter**, and the following prompt appears:

```
<sysname>
```

You can now configure the router.

Examining the router after power-on

After the router is powered on, verify that:

- The LEDs on the front panel are operating correctly:

LED	Status	Description
PWR	Steady green	The power module is supplying power correctly.
SYS	Slow flashing green	The router is operating correctly.

- The configuration terminal displays information correctly. For local configuration, the configuration terminal displays the boot information (see "[Observing boot information](#)").
- If you press **Enter** as prompted after system bootup, the router is ready to configure.

Configuring basic settings for the router

After the router is powered on for the first time, configure the basic settings for the router. For information about configuring the MSR1003-8 router, see *HPE MSR Routers Fundamentals Configuration Guide (V5)* and *HPE MSR Routers Fundamentals Command Reference (V5)*. For information about configuring the MSR1002-4 and MSR1003-8S routers, see *HPE MSR Routers Fundamentals Configuration Guide (V7)* and *HPE MSR Routers Fundamentals Command Reference (V7)*.

Replacement procedure

△ CAUTION:

SICs and DSICs are not hot swappable. Make sure the router is powered off before replacing a SIC or DSIC.

Replacing a SIC

1. Loosen the captive screws on the SIC.
2. Gently pull the SIC out along the slide rails.
3. Install a new SIC. For the installation procedure, see "Installing the router."
If you do not install a SIC, install a filler panel and tighten the screws.

Figure 21 Removing a SIC

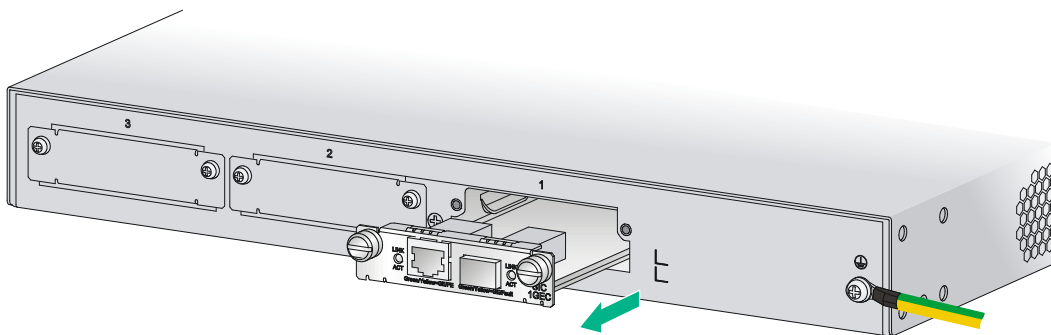
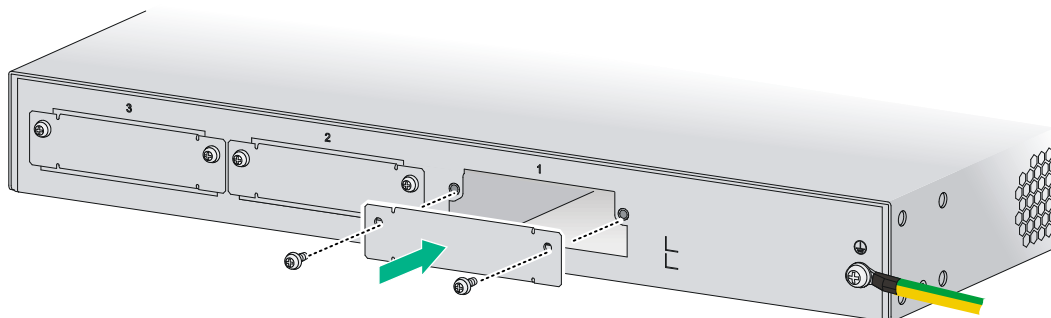

Figure 22 Installing a filler panel



Replacing a DSIC

1. Loosen the captive screws on the DSIC.
2. Gently pull the DSIC out along the slide rails.
If you need to install a DSIC or SICs, see "Installing the router" for the installation procedure.
To install filler panels, proceed to steps 3 and 4.
3. Gently push the slot divider into the DSIC slot along the slide rails and tighten the screws.

4. Install the filler panels and tighten the screws.

Figure 23 Removing a DSIC

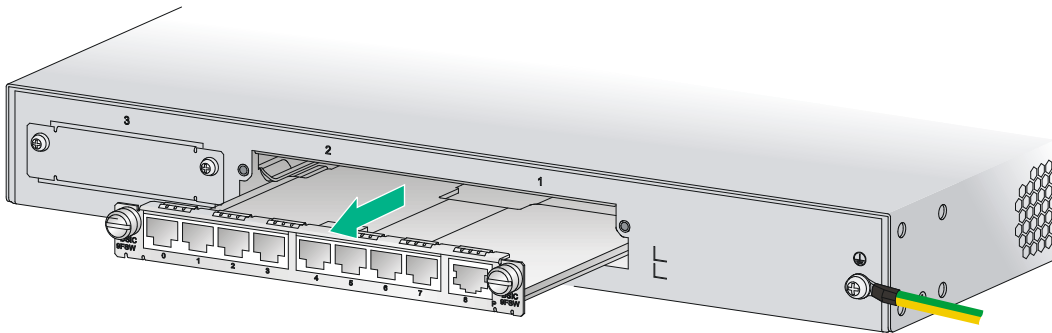

Figure 24 Installing the slot divider

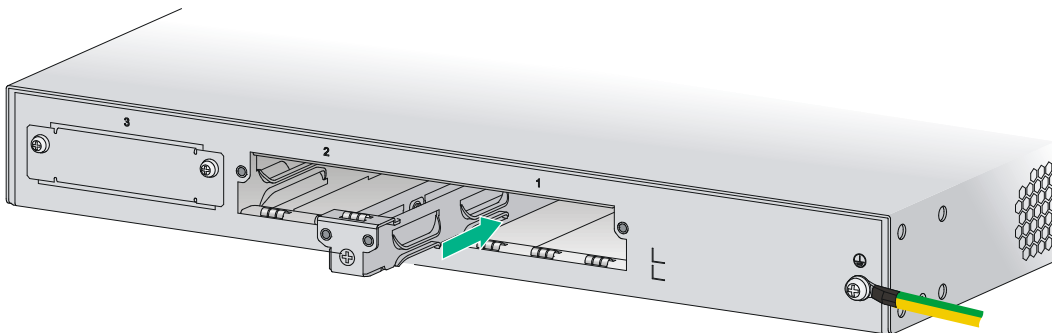
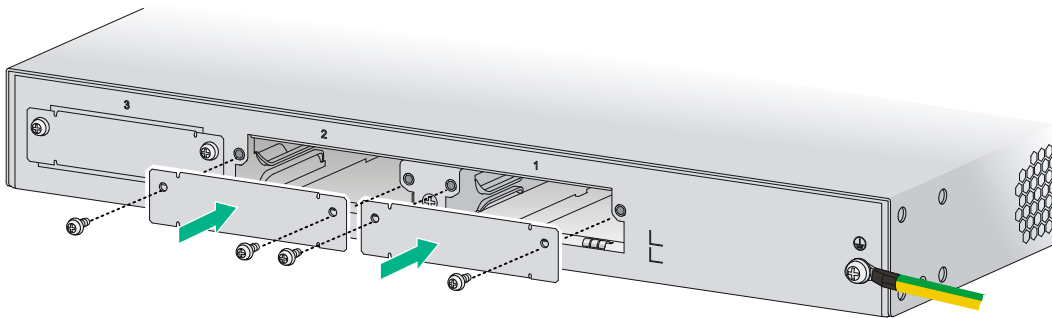

Figure 25 Installing filler panels



Troubleshooting

ⓘ IMPORTANT:

- The barcode on the router chassis contains product information that must be provided to local sales agent before you return a faulty router for service.
 - Keep the tamper-proof seal on a mounting screw on the chassis cover intact, and if you want to open the chassis, contact Hewlett Packard Enterprise for permission. Otherwise, Hewlett Packard Enterprise shall not be liable for any consequence.
-

Power supply failure

If the router cannot be powered on and LEDs on the front panel are off, the power supply is faulty.

To troubleshoot the power supply:

1. Power off the router.
2. Verify that the router's power cords are connected correctly.
3. Verify that the power source is operating correctly.
4. Determine if the power cord is damaged.
5. If the problem persists, contact Hewlett Packard Enterprise Support.

System configuration problems

If the configuration environment setup is correct, the console terminal displays boot information when the router is powered on. If the setup is incorrect, the console terminal displays nothing or garbled text.

No terminal display

If the console terminal displays nothing when the router is powered on, verify the following items:

- The power supply system is operating correctly.
- The console cable is connected correctly.
- The console cable is connected to the serial port that is configured for the console terminal.
- The console terminal properties are set as follows:
 - **Baud rate**—9,600
 - **Data bits**—8
 - **Parity**—none
 - **Stop bits**—1
 - **Flow control**—none
- The console cable is operating correctly.

Garbled terminal display

If terminal display is garbled, make sure the **Data bits** field for the console terminal is set to **8**. If the **Data bits** field is set to **5** or **6**, the console terminal will display garbled characters.

No response from the serial port

If the serial port does not respond, verify that the serial cable is in good condition and the serial port settings are correct.

Restoring the factory settings

Scenario 1

Symptom

When you replace the router, the router password is lost. As a result, you cannot log in to the router and do not know the router configuration.

Solution

Because the router is replaced, you do not need to save the configuration of the router. In this case, you can press the **Reset** button for more than 4 seconds to reboot the router and restore the factory settings. Then, you can use the username and password shipped with the router to log in to the router.

When the router configuration must be saved and you have a console cable, you can log in to the router from the BootWare menu.

Scenario 2

Symptom

After the configuration is modified, the network connectivity is lost. When you check the configuration, the configuration is very complicated and it is hard to locate the errors. In this case, you must configure the router again.

Solution

If you have not saved any configuration, you can reboot the router by pressing the **Reset** button for a short time or power off the router.

If you have saved the configuration, delete the configuration file at the CLI, and press the **Reset** button to restore the factory settings.

Scenario 3

Symptom

The router crashes.

Solution

Press the **Reset** button for a short time to reboot the router.

Reset button usage guidelines

An MSR1000 router provides the **Reset** button. You can use the button to reboot the system or restore the factory settings.

1. Press the **Reset** button for a short time to reboot the router.
2. Press the **Reset** button for more than 4 seconds to reboot the router and restore the factory settings.

Appendix A Chassis views and technical specifications

Chassis views

The following figures are for illustration only.

MSR1002-4

Figure 26 Front view

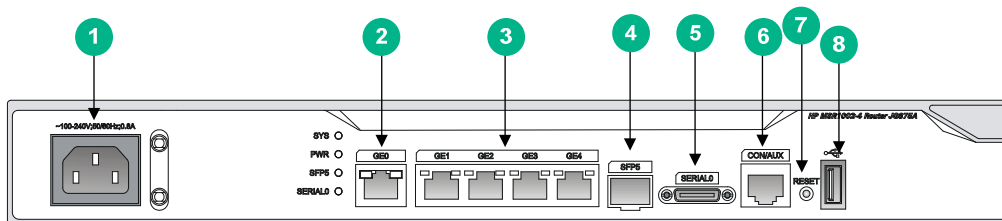

- | | | |
|--------------------------|---|---|
| (1) Power receptacle | (2) Gigabit Ethernet port (GE0) | (3) Gigabit Ethernet ports (GE1 to GE4) |
| (4) SFP port (SFP5) | (5) Asynchronous/synchronous serial interface (SERIAL0) | (6) Console port/AUX port (CON/AUX) |
| (7) Reset button (RESET) | (8) USB port | |

Figure 27 Rear view

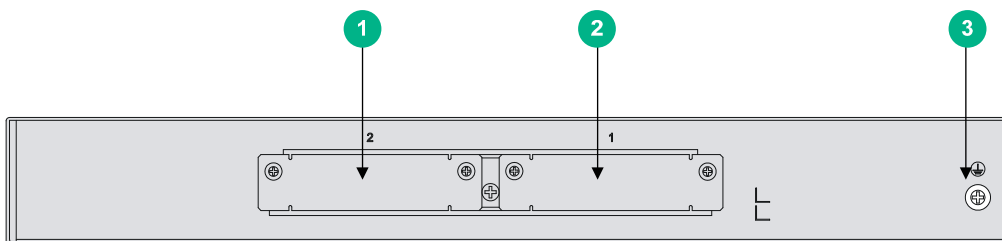

- | | | |
|----------------|----------------|------------------------|
| (1) SIC slot 2 | (2) SIC slot 1 | (3) Grounding terminal |
|----------------|----------------|------------------------|

MSR1003-8

Figure 28 Front view

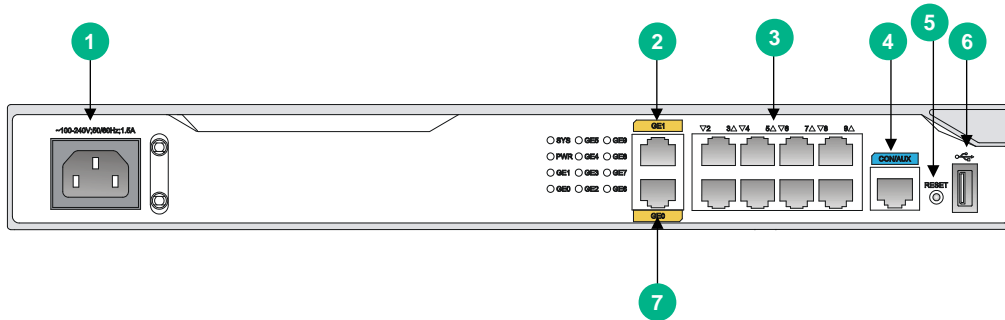

- | | | |
|-------------------------------------|---------------------------------|---|
| (1) Power receptacle | (2) Gigabit Ethernet port (GE1) | (3) Gigabit Ethernet ports (GE2 to GE8) |
| (4) Console port/AUX port (CON/AUX) | (5) Reset button (RESET) | (6) USB port |
| (7) Gigabit Ethernet port (GE0) | | |

Figure 29 Rear view

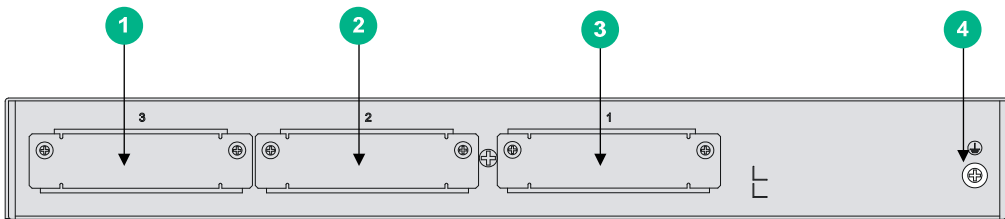

- | | |
|----------------|------------------------|
| (1) SIC slot 3 | (2) SIC slot 2 |
| (3) SIC slot 1 | (4) Grounding terminal |

MSR1003-8S

Figure 30 Front view

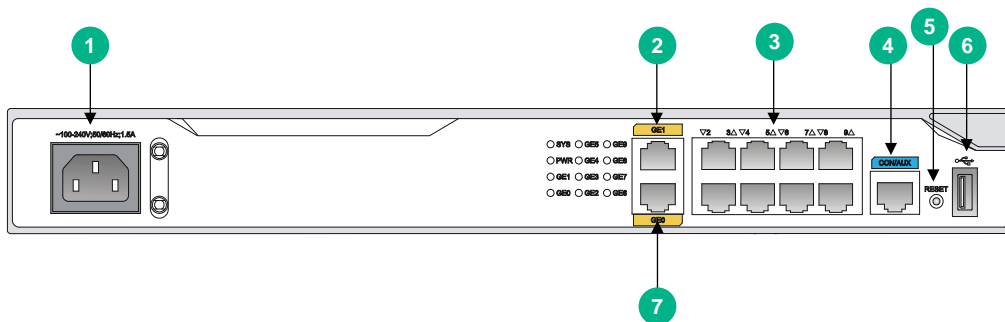

- | | | |
|-------------------------------------|---------------------------------|---|
| (1) Power receptacle | (2) Gigabit Ethernet port (GE1) | (3) Gigabit Ethernet ports (GE2 to GE8) |
| (4) Console port/AUX port (CON/AUX) | (5) Reset button (RESET) | (6) USB port |
| (7) Gigabit Ethernet port (GE0) | | |

Figure 31 Rear view

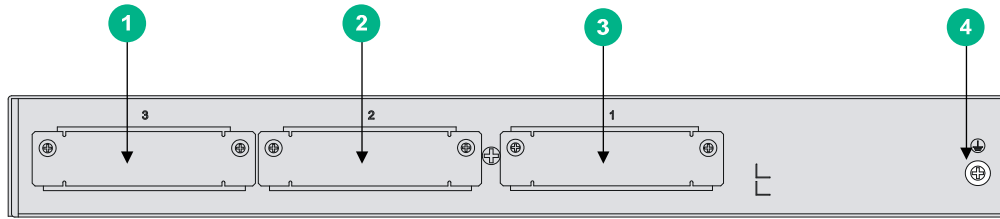

- | | |
|----------------|------------------------|
| (1) SIC slot 3 | (2) SIC slot 2 |
| (3) SIC slot 1 | (4) Grounding terminal |

Technical specifications

Item	MSR1002-4	MSR1003-8	MSR1003-8S
Console/AUX port	1	1	1
USB port	1	1	1
Gigabit Ethernet port	5	10	10
SFP port	1	N/A	N/A
Asynchronous/synchronous serial interface	1	N/A	N/A
Memory	1 GB DDR3	1 GB DDR3	1 GB DDR3
Flash	256 MB	256 MB	256 MB
SIC/DSIC slot	2 SIC slot (1 DSIC slot)	3 SIC slots (1 DSIC slot)	3 SIC slots (1 DSIC slot)
Dimensions (H × W × D) (excluding rubber feet and mounting brackets)	44.2 × 360 × 300 mm (1.74 × 14.17 × 11.81 in)	44.2 × 360 × 300 mm (1.74 × 14.17 × 11.81 in)	44.2 × 360 × 300 mm (1.74 × 14.17 × 11.81 in)
AC power supply	Rated voltage range: 90 VAC to 264 VAC @ 50 Hz/60 Hz	Rated voltage range: 90 VAC to 264 VAC @ 50 Hz/60 Hz	Rated voltage range: 90 VAC to 264 VAC @ 50 Hz/60 Hz
Rated power for AC power supply	30 W	30 W	30 W
Operating temperature	0°C to 45°C (32°F to 113°F)	0°C to 45°C (32°F to 113°F)	0°C to 45°C (32°F to 113°F)
Relative humidity (noncondensing)	5% to 90%	5% to 90%	5% to 90%

Appendix B LEDs

Panel LEDs

Figure 32 MSR1002-4 LEDs

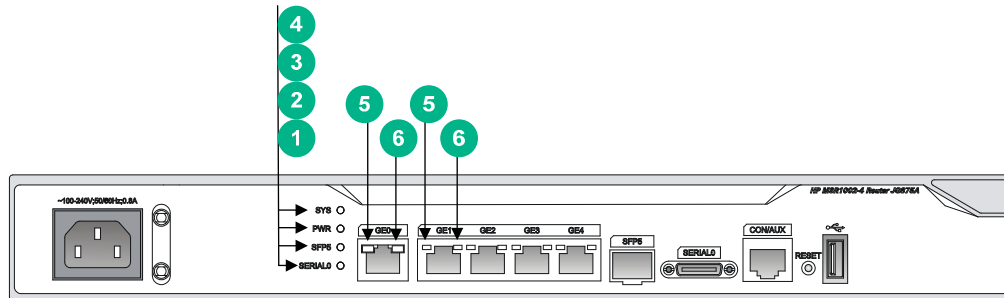

- | | | |
|---|--|--|
| (1) Asynchronous/synchronous serial interface LED (SERIAL0) | (2) SFP port LED (SFP5) | (3) Power supply LED (PWR) |
| (4) System status LED (SYS) | (5) 10/100 Mbps link LED for the Gigabit Ethernet port | (6) 1000 Mbps link LED for the Gigabit Ethernet port |

Figure 33 MSR1003-8 LEDs

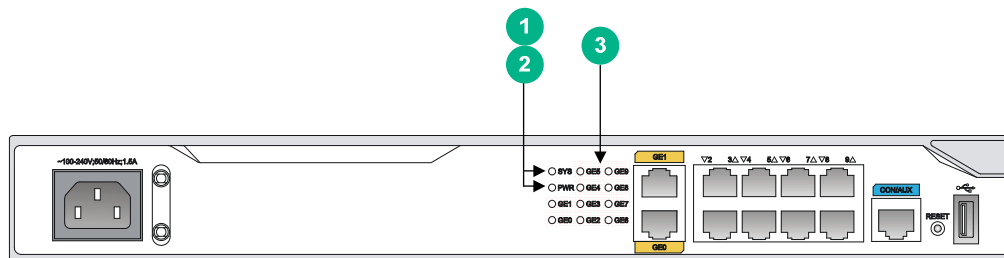

- | | | |
|----------------------|----------------------------|---|
| (1) System LED (SYS) | (2) Power supply LED (PWR) | (3) Gigabit Ethernet port LEDs (GE0 to GE9) |
|----------------------|----------------------------|---|

Figure 34 MSR1003-8S LEDs

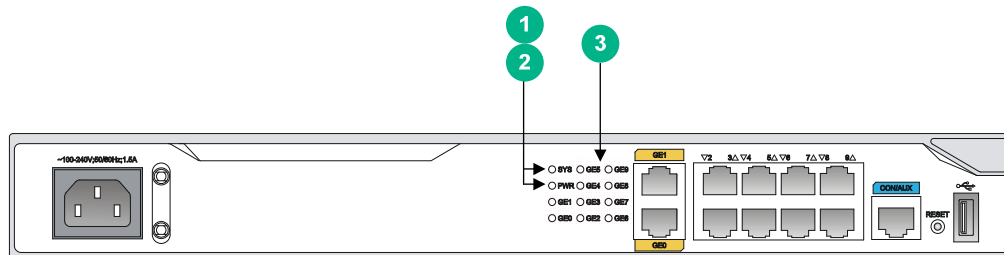

- | | | |
|----------------------|----------------------------|---|
| (1) System LED (SYS) | (2) Power supply LED (PWR) | (3) Gigabit Ethernet port LEDs (GE0 to GE9) |
|----------------------|----------------------------|---|

LED description



LED	State	Description	
SYS	Flashing green (1 Hz)	Comware has started with the configuration file and the router has booted up.	
	Flashing green (8 Hz)	The BootWare runs.	
	Steady green	The SDRAM is performing self-test.	
	Flashing yellow (1 Hz)	The DDR3 SDRAM has failed the self-test.	
	Flashing yellow (8 Hz)	The extended segment does not exist.	
	Steady yellow	The boot image does not exist.	
	Off	No power input, or exceptions have occurred.	
PWR	Steady green	The power supply is operating correctly.	
	Off	No power input.	
SERIAL0	Steady green	A link is present.	
	Flashing green	Data is being received or transmitted.	
	Off	No link is present.	
GE	1000 Mbps link LED	Steady green	A 1000 Mbps link is present.
		Flashing green	Data is being received or transmitted at 1000 Mbps.
		Off	No 1000 Mbps link is present.
	10/100 Mbps link LED	Steady yellow	A 10/100 Mbps link is present.
		Flashing yellow	Data is being received or transmitted at 10/100 Mbps.
		Off	No 10/100 Mbps link is present.
SFP	Steady green	A 1000 Mbps link is present.	
	Flashing green	Data is being received or transmitted at 1000 Mbps.	
	Steady yellow	A 10/100 Mbps link is present.	
	Flashing yellow	Data is being received or transmitted at 10/100 Mbps.	
	Off	No link is present.	

Appendix C Slot arrangement

The router provides slots for SICs. A DSIC can be installed if you remove the slot divider between two SIC slots.

The slot number of fixed ports on the router is 0.

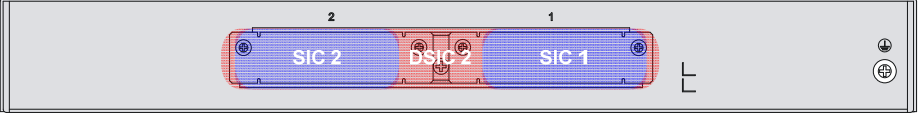
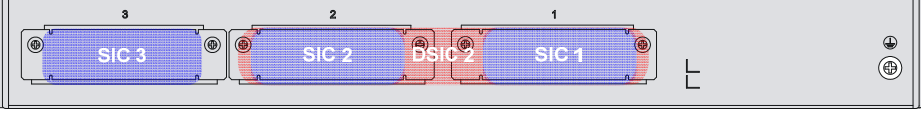
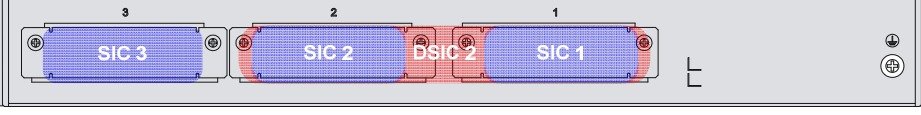
Table 6 Slot arrangement on the router

Router	Slot arrangement
MSR1002-4	
MSR1003-8	
MSR1003-8S	
<p>  : SIC slot  : DSIC slot </p>	

Document conventions and icons

Conventions

This section describes the conventions used in the documentation.

Port numbering in examples

The port numbers in this document are for illustration only and might be unavailable on your device.





Command conventions

Convention	Description
Boldface	Bold text represents commands and keywords that you enter literally as shown.
<i>Italic</i>	<i>Italic</i> text represents arguments that you replace with actual values.
[]	Square brackets enclose syntax choices (keywords or arguments) that are optional.
{ x y ... }	Braces enclose a set of required syntax choices separated by vertical bars, from which you select one.
[x y ...]	Square brackets enclose a set of optional syntax choices separated by vertical bars, from which you select one or none.
{ x y ... } *	Asterisk marked braces enclose a set of required syntax choices separated by vertical bars, from which you select at least one.
[x y ...] *	Asterisk marked square brackets enclose optional syntax choices separated by vertical bars, from which you select one choice, multiple choices, or none.
&<1-n>	The argument or keyword and argument combination before the ampersand (&) sign can be entered 1 to n times.
#	A line that starts with a pound (#) sign is comments.













GUI conventions

Convention	Description
Boldface	Window names, button names, field names, and menu items are in Boldface. For example, the New User window appears; click OK .
>	Multi-level menus are separated by angle brackets. For example, File > Create > Folder .

Symbols

Convention	Description
 WARNING!	An alert that calls attention to important information that if not understood or followed can result in personal injury.
 CAUTION:	An alert that calls attention to important information that if not understood or followed can result in data loss, data corruption, or damage to hardware or software.
 IMPORTANT:	An alert that calls attention to essential information.
NOTE:	An alert that contains additional or supplementary information.
 TIP:	An alert that provides helpful information.

Network topology icons

Convention	Description
	Represents a generic network device, such as a router, switch, or firewall.
	Represents a routing-capable device, such as a router or Layer 3 switch.
	Represents a generic switch, such as a Layer 2 or Layer 3 switch, or a router that supports Layer 2 forwarding and other Layer 2 features.
	Represents an access controller, a unified wired-WLAN module, or the access controller engine on a unified wired-WLAN switch.
	Represents an access point.
	Represents a wireless terminator unit.
	Represents a wireless terminator.
	Represents a mesh access point.
	Represents omnidirectional signals.
	Represents directional signals.
	Represents a security product, such as a firewall, UTM, multiservice security gateway, or load balancing device.
	Represents a security card, such as a firewall, load balancing, NetStream, SSL VPN, IPS, or ACG card.

Support and other resources

Accessing Hewlett Packard Enterprise Support

- For live assistance, go to the Contact Hewlett Packard Enterprise Worldwide website:
www.hpe.com/assistance
- To access documentation and support services, go to the Hewlett Packard Enterprise Support Center website:
www.hpe.com/support/hpesc

Information to collect

- Technical support registration number (if applicable)
- Product name, model or version, and serial number
- Operating system name and version
- Firmware version
- Error messages
- Product-specific reports and logs
- Add-on products or components
- Third-party products or components

Accessing updates

- Some software products provide a mechanism for accessing software updates through the product interface. Review your product documentation to identify the recommended software update method.
- To download product updates, go to either of the following:
 - Hewlett Packard Enterprise Support Center **Get connected with updates** page:
www.hpe.com/support/e-updates
 - Software Depot website:
www.hpe.com/support/softwaredepot
- To view and update your entitlements, and to link your contracts, Care Packs, and warranties with your profile, go to the Hewlett Packard Enterprise Support Center **More Information on Access to Support Materials** page:
www.hpe.com/support/AccessToSupportMaterials

ⓘ **IMPORTANT:**

Access to some updates might require product entitlement when accessed through the Hewlett Packard Enterprise Support Center. You must have an HP Passport set up with relevant entitlements.

Websites

Website	Link
Networking websites	
Hewlett Packard Enterprise Information Library for Networking	www.hpe.com/networking/resourcefinder
Hewlett Packard Enterprise Networking website	www.hpe.com/info/networking
Hewlett Packard Enterprise My Networking website	www.hpe.com/networking/support
Hewlett Packard Enterprise My Networking Portal	www.hpe.com/networking/mynetworking
Hewlett Packard Enterprise Networking Warranty	www.hpe.com/networking/warranty
General websites	
Hewlett Packard Enterprise Information Library	www.hpe.com/info/enterprise/docs
Hewlett Packard Enterprise Support Center	www.hpe.com/support/hpesc
Hewlett Packard Enterprise Support Services Central	ssc.hpe.com/portal/site/ssc/
Contact Hewlett Packard Enterprise Worldwide	www.hpe.com/assistance
Subscription Service/Support Alerts	www.hpe.com/support/e-updates
Software Depot	www.hpe.com/support/softwaredepot
Customer Self Repair (not applicable to all devices)	www.hpe.com/support/selfrepair
Insight Remote Support (not applicable to all devices)	www.hpe.com/info/insightremotesupport/docs

Customer self repair

Hewlett Packard Enterprise customer self repair (CSR) programs allow you to repair your product. If a CSR part needs to be replaced, it will be shipped directly to you so that you can install it at your convenience. Some parts do not qualify for CSR. Your Hewlett Packard Enterprise authorized service provider will determine whether a repair can be accomplished by CSR.

For more information about CSR, contact your local service provider or go to the CSR website:

www.hpe.com/support/selfrepair

Remote support

Remote support is available with supported devices as part of your warranty, Care Pack Service, or contractual support agreement. It provides intelligent event diagnosis, and automatic, secure submission of hardware event notifications to Hewlett Packard Enterprise, which will initiate a fast and accurate resolution based on your product's service level. Hewlett Packard Enterprise strongly recommends that you register your device for remote support.

For more information and device support details, go to the following website:

www.hpe.com/info/insightremotesupport/docs

Documentation feedback

Hewlett Packard Enterprise is committed to providing documentation that meets your needs. To help us improve the documentation, send any errors, suggestions, or comments to Documentation Feedback (docsfeedback@hpe.com). When submitting your feedback, include the document title,

part number, edition, and publication date located on the front cover of the document. For online help content, include the product name, product version, help edition, and publication date located on the legal notices page.

Index

A

AC

connecting power cord, 19

accessories (installation), 4

Appendix

A, chassis views and technical specifications, 28

B, LEDs, 31

C, slot arrangement, 33

B

boot information, 21

C

cable

connecting console cable, 18

troubleshooting no response from serial port, 27

chassis

views, 28

chassis views, 28

configuring

basic settings for router, 23

troubleshooting system problems, 26

connecting

AC power cord, 19

console cable, 18

router, 17

console

connecting cable, 18

troubleshooting garbled terminal display, 26

troubleshooting no terminal display, 26

console port

logging in, 18

console terminal

power-on examination, 22

D

DSIC

replacing, 24

E

electrical

EMI prevention, 3

grounding router through rack, 12

grounding router with buried grounding conductor, 15

grounding router with grounding strip, 14

grounding the router, 12

lightning protection, 4

power supply failure, 26

powering on the router, 20, 20

EMI (site requirements), 3

F

factory settings

restoring, 27

failure (power supply), 26

G

garbled terminal display (troubleshooting), 26

grounding

buried grounding conductor, 15

grounding strip, 14

rack, 12

router, 12

H

hardware

grounding router through rack, 12

grounding router with buried grounding conductor, 15

grounding router with grounding strip, 14

grounding the router, 12

replacing DSIC, 24

replacing SIC, 24

router installation, 7, 9

router rack installation, 9

router workbench installation, 9

I

installation site

cleanliness, 2

cooling system, 2

ESD prevention, 3

temperature and humidity, 2

installing

accessories required, 4

checklist before installation, 5

electricity safety, 1

general safety recommendations, 1

preparing for installation, 1

router, 7, 9

router in rack, 9

router on workbench, 9

safety recommendations, 1

- safety symbols, 1
- SIC, 15, 16
- verifying installation, 20

interface module

- installing SIC, 15, 16
- replacing DSIC, 24
- replacing SIC, 24
- SIC installation, 15, 16

L

LED

- power-on examination, 22

lightning protection (site requirements), 4

logging in

- console port, 18

N

network

- connecting router, 17

network management

- router installation, 7, 9

no response from serial port (troubleshooting), 27

no terminal display (troubleshooting), 26

P

port (troubleshooting no response), 27

power cord

- connecting AC, 19

power supply

- connecting power cord, 19
- troubleshooting failure, 26

powering on (router), 20, 20

power-on examination, 22

power-on verification, 20

preparing for installation

- checklist, 5
- cleanliness, 2
- cooling system, 2
- electricity safety, 1
- EMI, 3
- ESD prevention, 3
- examining the installation site, 2
- general safety recommendations, 1
- lightning protection, 4
- rack-mounting, 4
- safety symbols, 1
- temperature and humidity, 2

procedure

- attaching USB device, 18
- configuring basic settings for router, 23
- connecting AC power cord, 19

- connecting console cable, 18
- connecting router, 17
- displaying boot information, 21
- grounding router through rack, 12
- grounding router with buried grounding conductor, 15
- grounding router with grounding strip, 14
- grounding the router, 12
- installing router in rack, 9
- installing router on workbench, 9
- installing SIC, 15, 16
- installing the router, 7, 9
- logging in through console port, 18
- powering on the router, 20, 20
- replacing DSIC, 24
- replacing SIC, 24
- restoring factory settings, 27
- troubleshooting garbled terminal display, 26
- troubleshooting no response from serial port, 27
- troubleshooting no terminal display, 26
- troubleshooting power supply failure, 26

R

rack (router installation), 9

replacing

- DSIC, 24
- SIC, 24

reset button

- usage guidelines, 27

router

- attaching USB device, 18
- connecting to network, 17

S

safety

- electricity safety, 1
- EMI prevention, 3
- general safety recommendations, 1
- installation recommendations, 1
- lightning protection, 4
- safety symbols, 1

SIC

- replacing, 24
- replacing DSIC, 24

site requirements

- EMI, 3
- lightning protection, 4
- rack-mounting, 4

T

technical specifications, 28

- AC power supply specifications, 30

- CF card memory, [30](#)
- CF card slot, [30](#)
- chassis dimensions, [30](#)
- chassis views, [28](#)
- CON/AUX port, [30](#)
- Gigabit Ethernet port, [30](#)
- LED description, [32](#)
- LEDs, [31](#)
- memory, [30](#)
- operating temperature, [30](#)
- relative humidity, [30](#)
- SIC/DSIC slot, [30](#)
- slot arrangement, [33](#)
- USB console port, [30](#)
- USB port, [30](#)

terminal

- system configuration problems, [26](#)
- troubleshooting garbled display, [26](#)
- troubleshooting no display, [26](#)

troubleshooting

- garbled terminal display, [26](#)
- no response from serial port, [27](#)
- no terminal display, [26](#)
- power supply failure, [26](#)
- reset button usage guidelines, [27](#)
- restoring factory settings, [27](#)
- system configuration problems, [26](#)

U

usage guidelines

- reset button, [27](#)

V

verification

- power-on, [20](#)

verifying installation, [20](#)

W

workbench (router installation), [9](#)