

Aspire one Series Service Guide

Service guide files and updates are available on the ACER/CSD web; for more information, please refer to <http://csd.acer.com.tw>

PRINTED IN TAIWAN

Revision History

Please refer to the table below for the updates made on Aspire one Series service guide.

Date	Chapter	Updates

Copyright

Copyright © 2008 by Acer Incorporated. All rights reserved. No part of this publication may be reproduced, transmitted, transcribed, stored in a retrieval system, or translated into any language or computer language, in any form or by any means, electronic, mechanical, magnetic, optical, chemical, manual or otherwise, without the prior written permission of Acer Incorporated.

Disclaimer

The information in this guide is subject to change without notice.

Acer Incorporated makes no representations or warranties, either expressed or implied, with respect to the contents hereof and specifically disclaims any warranties of merchantability or fitness for any particular purpose. Any Acer Incorporated software described in this manual is sold or licensed "as is". Should the programs prove defective following their purchase, the buyer (and not Acer Incorporated, its distributor, or its dealer) assumes the entire cost of all necessary servicing, repair, and any incidental or consequential damages resulting from any defect in the software.

Acer is a registered trademark of Acer Corporation.

Intel is a registered trademark of Intel Corporation.

Pentium and Pentium II/III are trademarks of Intel Corporation.

Other brand and product names are trademarks and/or registered trademarks of their respective holders.

Conventions

The following conventions are used in this manual:

SCREEN MESSAGES	Denotes actual messages that appear on screen.
NOTE	Gives bits and pieces of additional information related to the current topic.
WARNING	Alerts you to any damage that might result from doing or not doing specific actions.
CAUTION	Gives precautionary measures to avoid possible hardware or software problems.
IMPORTANT	Reminds you to do specific actions relevant to the accomplishment of procedures.

Preface

Before using this information and the product it supports, please read the following general information.

1. This Service Guide provides you with all technical information relating to the BASIC CONFIGURATION decided for Acer's "global" product offering. To better fit local market requirements and enhance product competitiveness, your regional office MAY have decided to extend the functionality of a machine (e.g. add-on card, modem, or extra memory capability). These LOCALIZED FEATURES will NOT be covered in this generic service guide. In such cases, please contact your regional offices or the responsible personnel/channel to provide you with further technical details.
2. Please note WHEN ORDERING FRU PARTS, that you should check the most up-to-date information available on your regional web or channel. If, for whatever reason, a part number change is made, it will not be noted in the printed Service Guide. For ACER-AUTHORIZED SERVICE PROVIDERS, your Acer office may have a DIFFERENT part number code to those given in the FRU list of this printed Service Guide. You MUST use the list provided by your regional Acer office to order FRU parts for repair and service of customer machines.

System Specifications	1
Features	1
System Block Diagram	3
Your Acer Notebook tour	4
Front View	4
Closed Front View	5
Left View	5
Right View	6
Bottom View	6
Indicators	7
TouchPad Basics	8
Using the Keyboard	9
Lock Keys and embedded numeric keypad	9
Windows Keys	10
Hot Keys	11
Special Key	12
Hardware Specifications and Configurations	13
 System Utilities	 19
BIOS Setup Utility	19
Navigating the BIOS Utility	19
Information	20
Main	21
Advanced	22
Security	23
Power	26
Boot	28
Exit	29
BIOS Flash Utility	30
DOS Flash Utility	31
WinFlash Utility	33
Remove HDD/BIOS Password Utilities	34
Miscellaneous Utilities	37
 Machine Disassembly and Replacement	 39
Disassembly Requirements	39
Related Information	39
General Information	40
Pre-disassembly Instructions	40
Disassembly Process	40
External Module Disassembly Process	41
External Modules Disassembly Flowchart	41
Removing the Battery Pack	42
Removing the SD Dummy Card	43
Removing the Lower Covers	44
Removing the Hard Disk Drive Module	46
Removing the DIMM Module	48
Removing the WLAN Module	49
Main Unit Disassembly Process	51
Main Unit Disassembly Flowchart	51
Removing the Keyboard	52
Removing the Upper Cover	54
Removing the Power Board	58
Removing the TouchPad Bracket	60

Table of Contents

Removing the LCD Module	63
Removing the RTC Battery	66
Removing the USB Board and Cable	67
Removing the Bluetooth Module	69
Removing the Mainboard and Power Cable	71
Removing the Speaker Module	74
Removing the Thermal Module	76
LCD Module Disassembly Process	78
LCD Module Disassembly Flowchart	78
Removing the LCD Bracket Extensions	79
Removing the LCD Bezel	80
Removing the Camera Board	82
Removing the LCD Panel	83
Removing the LCD Brackets and FPC Cable	84
Removing the Microphone Board	86
Removing the Camera Cable	87
Removing the Antennas	88
LCD Module Reassembly Procedure	89
Replacing the Antennas, Camera Cable, and MIC	89
Replacing the LCD Cable and Brackets	91
Replacing the LCD Panel	93
Replacing the Camera Module	94
Replacing the LCD Bezel	95
Replacing the LCD Bracket Extensions	97
Main Module Reassembly Procedure	98
Replacing the Thermal Module	98
Replacing the Speaker Module	99
Replacing the Mainboard	101
Replacing the Bluetooth Module	102
Replacing the USB Board	103
Replacing the LCD Module	104
Replacing the TouchPad Bracket	107
Replacing the Power Board	108
Replacing the Upper Cover	109
Replacing the Keyboard	112
Replacing the WLAN Board	113
Replacing the DIMM Module	114
Replacing the Hard Disk Drive Module	114
Replacing the Lower Covers	115
Replacing the SD Dummy Card	116
Replacing the Battery	116

Troubleshooting

117

Common Problems	117
Power On Issue	118
No Display Issue	119
Random Loss of BIOS Settings	120
LCD Failure	121
Built-In Keyboard Failure	121
TouchPad Failure	122
Internal Speaker Failure	122
Internal Microphone Failure	124
HDD Not Operating Correctly	125
USB Failure (Rightside)	126
Power Button Failure	126

Table of Contents

External Mouse Failure	127
Other Failures	127
Intermittent Problems	128
Undetermined Problems	128
POST Code Reference Tables	129
Sec:	129
Memory:	129
BDS & Specific action:	130
Each PEIM entry point used in 80_PORT	131
Each Driver entry point used in 80_PORT	131
Each SmmDriver entry point used in 80_PORT	134
Jumper and Connector Locations	135
Top View	135
Bottom View	136
Clearing Password Check and BIOS Recovery	137
Clearing Password Check	137
BIOS Recovery by Crisis Disk	138
FRU (Field Replaceable Unit) List	139
Aspire one Exploded Diagrams	140
Main Assembly	140
Upper Cover Assembly	141
Lower Cover Assembly	142
LCD Assembly	143
Aspire one FRU List	144
Screw List	157
Model Definition and Configuration	158
Aspire one Series	158
Test Compatible Components	211
Windows XP Environment Test	212
Online Support Information	217
Index	219

Table of Contents

System Specifications

Features

Below is a brief summary of the computer's many feature:

Operating System

- Microsoft Windows® XP™ / Linux

Platform

- Intel® Atom™ Processor N270 FSB 533/667 MHz
- Intel 945GSE + ICH7M Chipset

System Memory

NOTE: It is not possible for end users to upgrade the Aspire one memory.

- One DDRII SO-DIMM slots support up to 2GB system memory
- Adjustable 128MB UMA VGA memory share from North Bridge

Display

- 10.1" 1024 x 600

Storage subsystem

- 2.5" hard disk drive
- Multi-in-1 card reader

Audio

- REALTEK ALC272X-GR for High Definition Audio Codec

Dimensions and Weight

- 248 (W) x 169.4 (D) x 29.5 (H) mm (ME dimension)
- 995g weight with 8.9" LCD and 8GB SSD

Communication

- On-Board PCI-E 10/100 LAN
- Mini-card Wireless LAN
- Wake-on-LAN support
- 3G Module through USB

Privacy control

- BIOS user, supervisor, and power on passwords
- Kensington lock slot

Special keys and controls

- New Acer Aspire one keyboard support
- Power button and Wireless LAN/3G switch

I/O interface

- 1 * Express card slot
- 1 * VGA port, 15 pins
- 1 * Microphone-in/Line-in
- 1 * Line-out / Headphone out
- 3 * External USB 2.0
- 1 * DC in jack
- 1 * RJ-45 jack for LAN
- 1 * Internal Digital MIC
- 1 * 5-in-1 card reader
- 1 * SD card reader

Environment

- Temperature:
 - Operating: 5 °C to 35 °C
 - Non-operating: -20 °C to 65 °C
- Humidity (non-condensing):
 - Operating: 20% to 80%
 - Non-operating: 20% to 80%

System Block Diagram

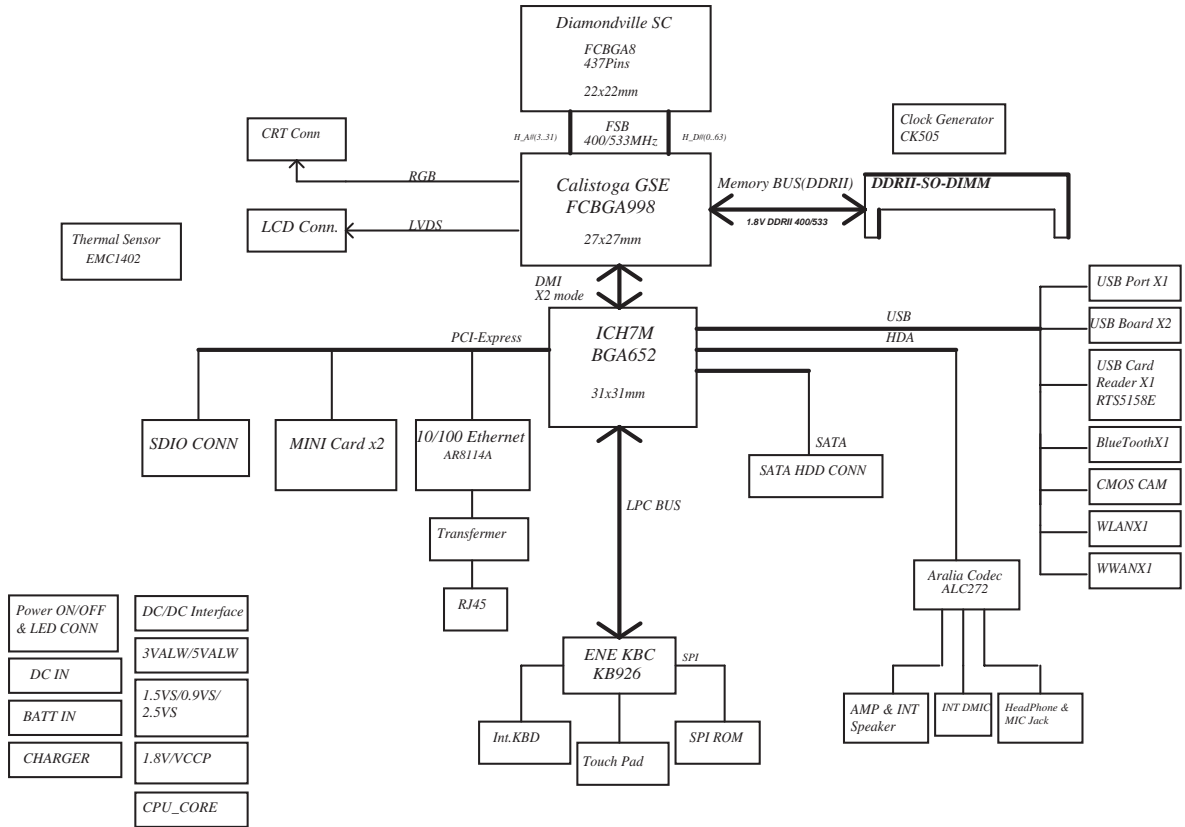





Your Acer Notebook tour

After knowing your computer features, let us show you around your new computer.

Front View



No.	Icon	Item	Description
1		Acer Crystal Eye Webcam	Web camera for video communication.
2		Microphone	Internal microphone for sound recording.
3		Display screen	Also called Liquid-Crystal Display (LCD), displays computer output.
4		Bluetooth communication switch/indicator	Enables/disables the Bluetooth function. Indicates the status of Bluetooth communication (only for certain models).
5		Status indicators	Light-Emitting Diodes (LEDs) that light up to show the status of the computer's functions and components.
6		Keyboard	For entering data into your computer.
7		TouchPad	Touch-sensitive pointing device which functions like a computer mouse.
8		Power indicator	
9		Click buttons (left and right)	The left and right buttons function like the left and right mouse buttons.

No.	Icon	Item	Description
10		Wireless LAN communication indicator	Indicates the status of wireless LAN communication.
11		Power button/indicator	Turns the computer on and off.







Closed Front View

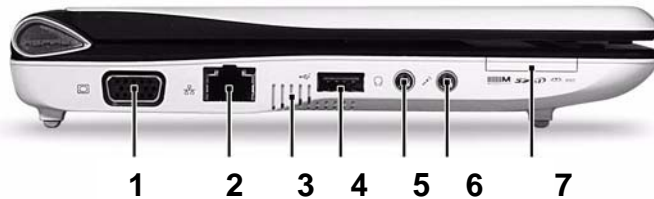

No.	Icon	Item	Description
1		Wireless communication switch	Enables/disables the wireless function.



Left View



No.	Icon	Item	Description
1		External display (VGA) port	Connects to a display device (e.g. external monitor, projector).
2		Ethernet (RJ-45) port	Connects to an Ethernet 10/100-based network.
3		Ventilation slots and cooling fan	Enable the computer to stay cool, even after prolonged use. Note: Do not cover or obstruct the fan opening.
4		USB 2.0 port	Connect to USB 2.0 devices (e.g. USB mouse).
5		Headphones/speaker/line-out jack	Connects to line-out audio devices (e.g. speakers, headphones).
6		Microphone-in jack	Accepts input from external microphones.
7		Multi-in-1 card reader	Accepts Secure Digital (SD), MultiMediaCard (MMC), Memory Stick (MS), Memory Stick PRO (MS PRO), xD-Picture Card (xD). Note: Push to remove/install the card. Only one card can operate at any given time.

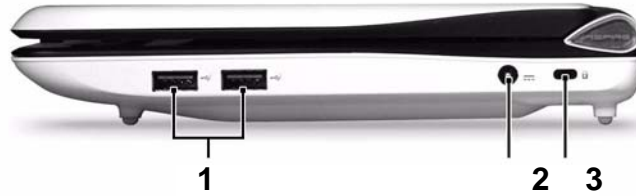



Right View

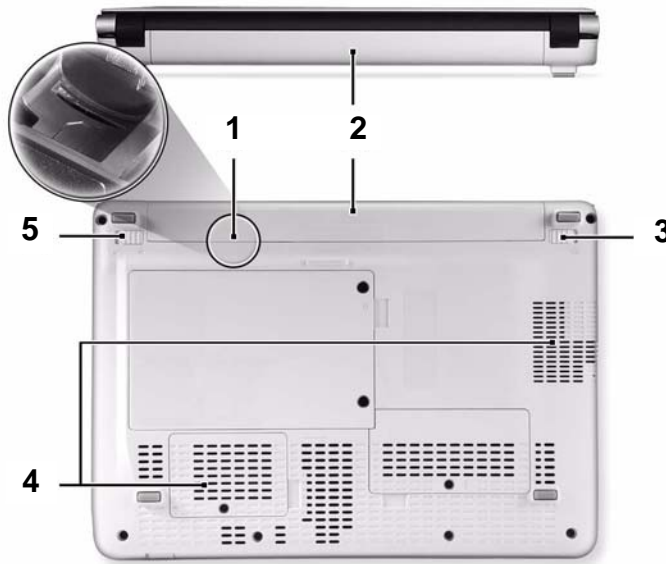

No.	Icon	Item	Description
1		USB 2.0 ports	Connect to USB 2.0 devices (e.g. USB mouse).
2		DC-in jack	Connects to an AC adapter
3		Kensington lock slot	Connects to a Kensington-compatible computer security lock.





Bottom View



No.	Icon	Item	Description
1		3G SIM card slot	Accepts a 3G SIM card for 3G connectivity (only for certain models).
2		Battery bay	Houses the computer's battery pack. Note: The battery shown is for reference only. Your PC may have a different battery, depending on the model purchased.
3		Battery release latch	Releases the battery for removal.
4		Ventilation slots	Vents enable the computer to stay cool, even after prolonged use. Note: Do not cover or obstruct the cooling vents.
5		Battery lock	Locks the battery in position.

Indicators

The computer has several easy-to-read status indicators. The battery indicator is visible even when the computer cover is closed.

Icon	Function	Description
	Battery	Indicates the computer's battery status.
	HDD	Indicates when the hard disk drive is active.
	Num Lock	Lights up when Num Lock is activated.
	Caps Lock	Lights up when Caps Lock is activated.

NOTE: 1. **Charging:** The battery light shows amber when the battery is charging. 2. **Fully charged:** The light shows green when in AC mode.

TouchPad Basics

The following items show you how to use the TouchPad:

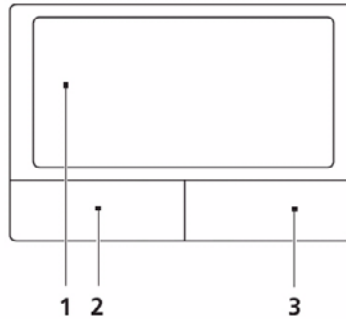

- Move your finger across the TouchPad (1) to move the cursor.
- Press the left (2) and right (3) buttons located beneath the TouchPad to perform selection and execution functions. These two buttons are similar to the left and right buttons on a mouse. Tapping on the TouchPad is the same as clicking the left button.

Function	Left Button (2)	Right Button (3)	Main TouchPad (1)
Execute	Quickly click twice.		Tap twice (at the same speed as double-clicking a mouse button).
Select	Click once.		Tap once.
Drag	Click and hold, then use finger on the TouchPad to drag the cursor.		Tap twice (at the same speed as double-clicking a mouse button); rest your finger on the TouchPad on the second tap and drag the cursor.
Access context menu		Click once.	

NOTE: When using the TouchPad, keep it - and your fingers - dry and clean. The TouchPad is sensitive to finger movement; hence, the lighter the touch, the better the response. Tapping too hard will not increase the TouchPad's responsiveness.

Using the Keyboard

Your Aspire one has a close-to-full-sized keyboard and an embedded numeric keypad, separate cursor, lock, function and special keys.

Lock Keys and embedded numeric keypad

The keyboard has three lock keys which you can toggle on and off.





















Lock key	Description
Caps Lock	When Caps Lock is on, all alphabetic characters typed are in uppercase.
Num Lock <Fn> + <F11>	When Num Lock is on, the embedded keypad is in numeric mode. The keys function as a calculator (complete with the arithmetic operators +, -, *, and /). Use this mode when you need to do a lot of numeric data entry. A better solution would be to connect an external keypad.
Scroll Lock <Fn> + <F12>	When Scroll Lock is on, the screen moves one line up or down when you press the up or down arrow keys respectively. Scroll Lock does not work with some applications.

The embedded numeric keypad functions like a desktop numeric keypad. It is indicated by small characters located on the upper right corner of the keycaps. To simplify the keyboard legend, cursor-control key symbols are not printed on the keys.

Desired access	Num Lock on	Num Lock off
Number keys on embedded keypad	Type numbers in a normal manner.	
Main keyboard keys	Hold <Fn> while typing letters on embedded keypad.	Type the letters in a normal manner.

Windows Keys

The keyboard has two keys that perform Windows-specific functions.

Key	Description
 Windows key	<p>Pressed alone, this key has the same effect as clicking on the Windows Start button; it launches the Start menu. It can also be used with other keys to provide a variety of functions:</p> <ul style="list-style-type: none"> <  >: Open or close the Start menu <  > + <D>: Display the desktop <  > + <E>: Open Windows Explore <  > + <F>: Search for a file or folder <  > + <G>: Cycle through Sidebar gadgets <  > + <L>: Lock your computer (if you are connected to a network domain), or switch users (if you're not connected to a network domain) <  > + <M>: Minimizes all windows <  > + <R>: Open the Run dialog box <  > + <T>: Cycle through programs on the taskbar <  > + <U>: Open Ease of Access Center <  > + <X>: Open Windows Mobility Center <  > + <BREAK>: Display the System Properties dialog box <  > + <SHIFT+M>: Restore minimized windows to the desktop <  > + <TAB>: Cycle through programs on the taskbar by using Windows Flip 3-D <  > + <SPACEBAR>: Bring all gadgets to the front and select Windows Sidebar <CTRL> + <  > + <F>: Search for computers (if you are on a network) <CTRL> + <  > + <TAB>: Use the arrow keys to cycle through programs on the taskbar by using Windows Flip 3-D <p>Note: Depending on your edition of Windows Vista, some shortcuts may not function as described.</p>
 Application key	<p>This key has the same effect as clicking the right mouse button; it opens the application's context menu.</p>

Hot Keys

The computer employs hotkeys or key combinations to access most of the computer's controls like screen brightness and volume output.

To activate hotkeys, press and hold the **<Fn>** key before pressing the other key in the hotkey combination.



Hotkey	Icon	Function	Description
<Fn> + <F1>	?	Hotkey help	Displays help on hotkeys.
<Fn> + <F2>		Acer eSettings Management	Launches Acer eSettings Management in Acer Empowering Technology.
<Fn> + <F3>		Acer ePower Management	Launches Acer ePower Management in Acer Empowering Technology.
<Fn> + <F4>	Z ^z	Sleep	Puts the computer in Sleep mode.
<Fn> + <F5>		Display toggle	Switches display output between the display screen, external monitor (if connected) and both.
<Fn> + <F6>		Screen blank	Turns the display screen backlight off to save power. Press any key to return.
<Fn> + <F7>		TouchPad toggle	Turns the internal TouchPad on and off.
<Fn> + <F8>		Speaker toggle	Turns the speakers on and off.
<Fn> + <▷>		Brightness up	Increases the screen brightness.
<Fn> + <◁>		Brightness down	Decreases the screen brightness.
<Fn> + <△>		Volume up	Increases the sound volume.
<Fn> + <▽>		Volume down	Decreases the sound volume.

Special Key

You can locate the Euro symbol and the US dollar sign at the upper-center and/or bottom-right of your keyboard.



The Euro symbol

1. Open a text editor or word processor.
2. Hold <Alt Gr> and then press the <5> key at the upper-center of the keyboard.

NOTE: Some fonts and software do not support the Euro symbol.

The US dollar sign

1. Open a text editor or word processor.
2. Hold <Shift> and then press the <4> key at the upper-center of the keyboard.

NOTE: This function varies according to the language settings.

Hardware Specifications and Configurations

Processor

Item	Specification
CPU type	Intel Atom N270 1.6G 512K 533 2.5W
CPU package	Micro-FCBGA8 packaging, 437-pin
Core Logic	<ul style="list-style-type: none"> Intel CS QG82945GSE MM#897840 ICH7M
Chipset	<ul style="list-style-type: none"> ENE KB926 for Keyboard Controller, Battery management Unit, and RTC. Integrated VGA solution for Intel 945GSE. Realtek ALC272X-GR for High Definition Audio Codec. Atheros AR8114A for 10/100 LAN
Features	<ul style="list-style-type: none"> On-die, primary 32-kB instructions cache and 24-kB write-back data cache 533-MHz source-synchronous front side bus (FSB) 2-Threads support On-die 512-kB, 8-way L2 cache Support for IA 32-bit architecture Intel® Streaming SIMD Extensions-2 and -3 (Intel® SSE2 and Intel® SSE3) support and Supplemental Streaming SIMD Extension 3 (SSSE3) support Micro-FCBGA8 packaging technologies Thermal management support via Intel® Thermal Monitor 1 and Intel Thermal Monitor 2 FSB Lane Reversal for flexible routing Supports C0/C1(e)/C2(e)/C4(e) L2 Dynamic Cache Sizing Advanced power management features including Enhanced Intel SpeedStep® Technology Execute Disable Bit support for enhanced security

Processor Specifications

Item	CPU Speed	Cores	Bus Speed	Mfg Tech	Cache Size	Package	Core Voltage	Acer P/N
N270	1.6 GHz	1	533 MHz	45 nm	512 KB	Micro-FCBGA8		KC.ANB01.270
N280	1.66 GHz	1	667 MHz	45 nm	512 KB	Micro-FCBGA8		KC.ANB01.280

CPU Fan Tru Value Table

CPU Temperature of Diode		Fan Speed (RPM)	SPL Spec (dBA)
--	40	0	0
35	50	4300	26
45	65	5000	29
60	85	5400	31
75	90	5400	31

- Throttling 50%: On= 85°C; OFF=75°C
- EC shut down at 90°C; H/W shut down(PH1) at 82°C

System Memory

Item	Specification
Memory controller	Built in
Memory size	512MB or 1GB DDR2 RAM (if 2Gb die support is available)
DIMM socket number	1
Supports memory size per socket	1GB
Supports maximum memory size	2 GB
Supports DIMM type	DDR II 533Mhz SDRAM memory interface design
Supports DIMM Speed	533Mhz SDRAM

System Storage

Item	Specification
HDD	<ul style="list-style-type: none"> • 9.5mm height, 2.5" HDD • Easily removable no more than two screws • SATA bus • 160/250GB and above • 5400 rpm • SATA connector BTO

Hard Disk Drive Interface

Item	Specification				
Vendor & Model Name	Seagate ST9160310AS	Seagate ST9250827AS	Seagate ST9250315AS	HGST L9A300 HTS543225 HTS543216	WD WD2500BEVT WD1600BEVT
Capacity (GB)	160	250	250	250, 160	250, 160
Bytes per sector	512	512	512	512	512
Data heads	2	4	2	3, 2	3, 2
Drive Format					
Disks	1	2	1	2, 1	2, 1
Spindle speed (RPM)	5400	5400	5400	5400	5400
Performance Specifications					
Buffer size	8 MB	8 MB	TBD	8 MB	8 MB
Interface	SATA	SATA	SATA	SATA	SATA
Fast data transfer rate (Mbits/sec, max)	352	778	TBD	3000	3000
Media data transfer rate (Mbytes/sec max)	150	300	TBD	775	850
DC Power Requirements					
Voltage tolerance	5V ±5%	5V ±5%	TBD	5V ±5%	5V ±5%

Hard Disk Drive Interface (cont.)

Item	Specification	
Vendor & Model Name	Toshiba MK1652GSX	Toshiba MK1655GSX
Capacity (GB)	160	160
Bytes per sector	512	
Data heads	2	2
Drive Format		
Disks	1	1
Spindle speed (RPM)	5400	5400
Performance Specifications		
Buffer size (MB)	8	8
Interface	SATA	SATA
Fast data transfer rate (Mbits/sec, max)	400 - 794 typical	395 - 952 typical
Media data transfer rate (Gbytes/sec max)	3	3
DC Power Requirements		
Voltage tolerance	5V \pm 5%	5V \pm 5%

BIOS

Item	Specification
BIOS vendor	InSyde
BIOS Version	v0.10
BIOS ROM type	Flash
BIOS ROM size	1 MB
Features	<ul style="list-style-type: none"> • Support ISIPP • Support Acer UI • Support multi-boot • Suspend to RAM (S3)/Disk (S4) • Various hot-keys for system control • Support SMBUS 2.0, PCI2.3 • ACPI 2.0 compliance with Intel Speed Step Support C1, C2, C3, C4 and S3, S4 for mobile CPU • DMI utility for BIOS serial number configurable/asset tag • Support PXE

LED 10.1”

Item	Specification
Vendor/model name	Chimei N101L6-L02, AUO B101AW03 V0, Samsung LTN101NT02-A01, LPL LP101WSA-TLA1
Screen Diagonal (mm)	257 (10.1")
Active Area (mm)	222.72x125.28
Display resolution (pixels)	1024x576
Pixel Pitch (mm)	0.2175
Typical White Luminance (cd/m ²) also called Brightness	200
Contrast Ratio	500:1

Item	Specification
Response Time (Optical Rise Time/Fall Time) msec	10
Typical Power Consumption (watt)	2.5
Weight (without inverter)	180
Physical Size (mm)	235.5 x 143.5 x 5.2
Electrical Interface	LVDS
Viewing Angle (degree)	
Horizontal (Right) CR = 10 (Left)	45/45
Vertical (Upper) CR = 10 (Lower)	20/45

Audio Codec and Amplifier

Item	Specification
Audio Controller	REALTEK ALC272X-GR
Features	<ul style="list-style-type: none"> • Two stereo DAC support 16/20/24-bit PCM for two independent playback (multiple streaming) • Two stereo ADC supports 16/20/24-bit PCM format for two independent recording • All DACs support independent 44.1k/48k/96k/192kHz sample rate • All ADCs support independent 44.1k/48k/96k/192kHz sample rate • Two independent SPDIF outputs support 16/20/24-bit format and 44.1k/48k/88.2k/96k/192kHz rate • Supports line level mono output • Supports analog PCBEEP input, and features an integrated digital BEEP generator • Support two stereo digital microphone input for microphone array AEC/BF application • Supports legacy analog mixer architecture • Supports two GPIO (General Purpose Input/Output) pins (pin sharing with digital microphone interface) • Supports EAPD (External Amplifier Power Down) control for external amplifier • Supports anti-pop mode when analog power AVDD is on and digital power is off • Supports 1.5V~3.3V scalable I/O for HD Audio link • 48-pin LQFP 'Green' package

LAN Interface

Item	Specification
LAN Chipset	Atheros AR8114
Features	•

Keyboard

Item	Specification
Type	New Acer flat keyboard
Total number of keypads	84
Windows logo key	Yes
Internal & external keyboard work simultaneously	Plug USB keyboard to the USB port directly: Yes

Mini Card

Item	Specification
Number Supported	2
Features	<ul style="list-style-type: none">• 2 mini card slot (1 for 3G and 1 for WLAN or WLAN/WiMax)• Embedded 3G module and built-in 1 antenna (combo wireless + 3G) on top/side of LCD

Camera

Item	Specification
Vendor and model	Suyin Camera Rosa Liteon Camera Lily
Type	0.3M LDV

3G Card

Item	Specification
Features	<ul style="list-style-type: none">• 3G card in mini-PCI card size• Control by USB interface• User accessible SIM card by battery remove• Antenna: Has to be placed on the sides of LCD in A/B cover

Wireless LAN

Item	Specification
Type	WiMax Intel Echo Peak 5150
Features	<ul style="list-style-type: none">• 802.16e+802.11a/g/h• 1x2 MIMO• Mini card/Half Mini card

Battery

Item	Specification	
Vendor & model name	SANYO UM-2008A, PANASONIC UM-2008AW, SIMPLO UM-2008A	SANYO UM-2008BW, PANASONIC UM-2008B, SIMPLO UM-2008A
Battery Type	Li-ion	Li-ion
Pack capacity	2200/2900 mAh	4400/5800 mAh
Number of battery cell	3	6
Package configuration	3S1P	3S2P

System Utilities

BIOS Setup Utility

The BIOS Setup Utility is a hardware configuration program built into your computer's BIOS (Basic Input/Output System).

Your computer is already properly configured and optimized, and you do not need to run this utility. However, if you encounter configuration problems, you may need to run Setup. Please also refer to Chapter 4 Troubleshooting when problem arises.

To activate the BIOS Utility, press **F2** during POST (when **Press <F2> to enter Setup** message is prompted on the bottom of screen).

Press **F2** to enter setup. The default parameter of F12 Boot Menu is set to "disabled". If you want to change boot device without entering BIOS Setup Utility, please set the parameter to "enabled".

Press **<F12>** during POST to enter multi-boot menu. In this menu, user can change boot device without entering BIOS SETUP Utility.

Navigating the BIOS Utility

There are six menu options: Information, Main, Advanced, Security, Power, Boot, and Exit.

Follow these instructions:

- To choose a menu, use the left and right arrow keys.
- To choose an item, use the up and down arrow keys.
- To change the value of a parameter, press **F5** or **F6**.
- A plus sign (+) indicates the item has sub-items. Press **Enter** to expand this item.
- Press **Esc** while you are in any of the menu options to go to the Exit menu.
- In any menu, you can load default settings by pressing **F9**. You can also press **F10** to save any changes made and exit the BIOS Setup Utility.

NOTE: You can change the value of a parameter if it is enclosed in square brackets. Navigation keys for a particular menu are shown on the bottom of the screen. Help for parameters are found in the Item Specific Help part of the screen. Read this carefully when making changes to parameter values. **Please note that system information is subject to different models.**

Information

The Information screen displays a summary of your computer hardware information.

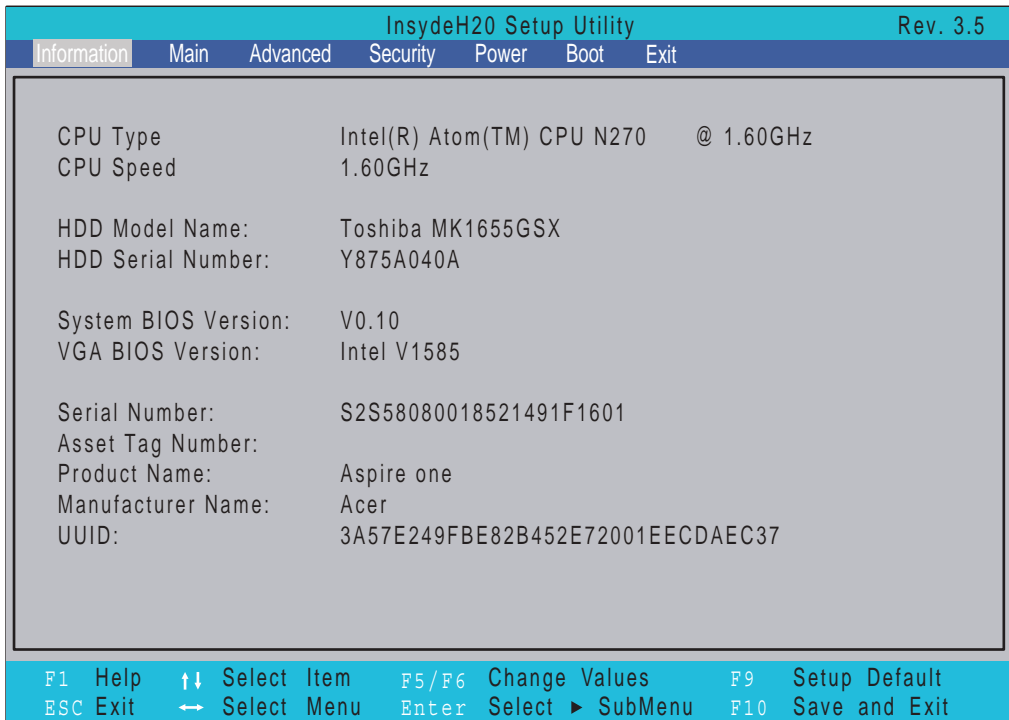

NOTE: The system information is subject to different models.

Parameter	Description
CPU Type	This field shows the CPU type and speed of the system.
CPU Speed	This field shows the speed of the CPU.
HDD Model Name	This field shows the model name of HDD installed on primary IDE master.
HDD Serial Number	This field displays the serial number of HDD installed on primary IDE master.
System BIOS Version	Displays system BIOS version.
VGA BIOS Version	This field displays the VGA firmware version of the system.
Serial Number	This field displays the serial number of this unit.
Asset Tag Number	This field displays the asset tag number of the system.
Product Name	This field shows product name of the system.
Manufacturer Name	This field displays the manufacturer of this system.
UUID Number	Universally Unique Identifier (UUID) is an identifier standard used in software construction, standardized by the Open Software Foundation (OSF) as part of the Distributed Computing Environment (DCE).

Main

The Main screen allows the user to set the system time and date as well as enable and disable boot option and recovery.

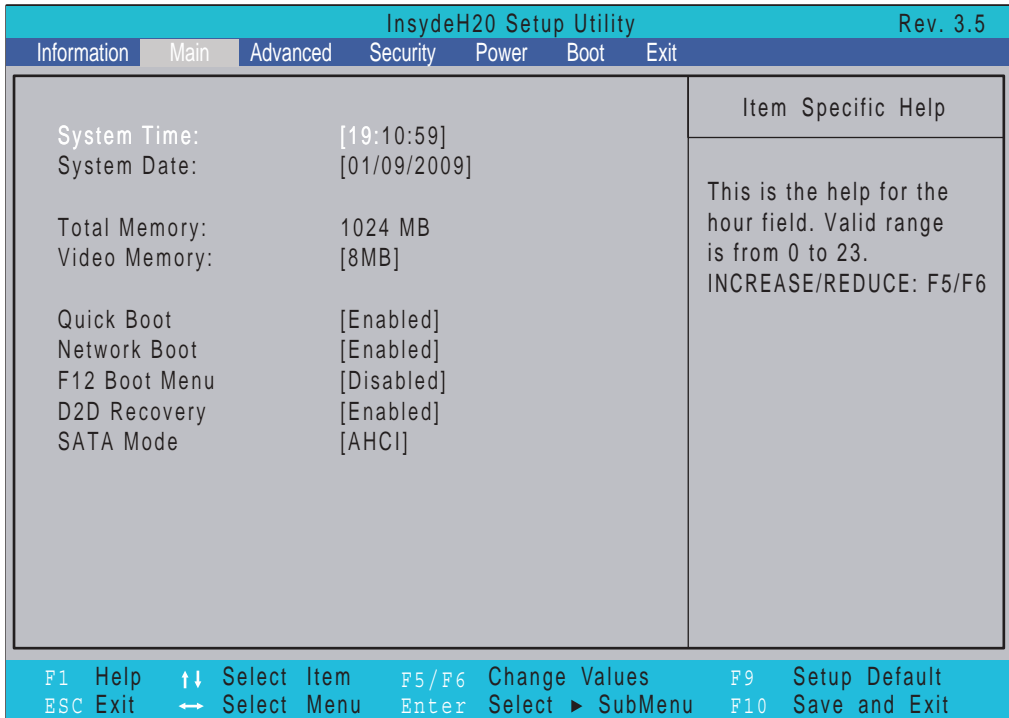

NOTE: The screen above is for your reference only. Actual values may differ.

The table below describes the parameters in this screen. Settings in **boldface** are the default and suggested parameter settings.

Parameter	Description	Format/Option
System Time	Sets the system time. The hours are displayed with 24-hour format.	Format: HH:MM:SS (hour:minute:second)
System Date	Sets the system date.	Format MM/DD/YYYY (month/day/year)
Total Memory	This field reports the memory size of the system. Memory size is fixed to 3017 MB.	N/A
Video Memory	Shows the video memory size. VGA Memory size=32 MB	N/A
Quick Boot	Allows startup to skip certain tests while booting, decreasing the time needed to boot the system.	Option: Enabled or Disabled
Network Boot	Enables, disables the system boot from LAN (remote server).	Option: Enabled or Disabled
F12 Boot Menu	Enables, disables Boot Menu during POST.	Option: Enabled or Enabled
D2D Recovery	Enables, disables D2D Recovery function. The function allows the user to create a hidden partition on hard disc drive to store operation system and restore the system to factory defaults.	Option: Enabled or Disabled
SATA Mode	Control the mode in which the SATA controller should operate.	Option: AHCI or IDE

Advanced

The Advanced screen allows the user to configure the various advanced BIOS options.

IMPORTANT: Making incorrect settings to items on these pages may cause the system to malfunction. Unless you have experience adjusting these items, we recommend that you leave these settings at the default values. If making settings to items on these pages causes your system to malfunction or prevents the system from booting, open BIOS and choose Load Optimal Defaults in the Exit menu to boot up normally.

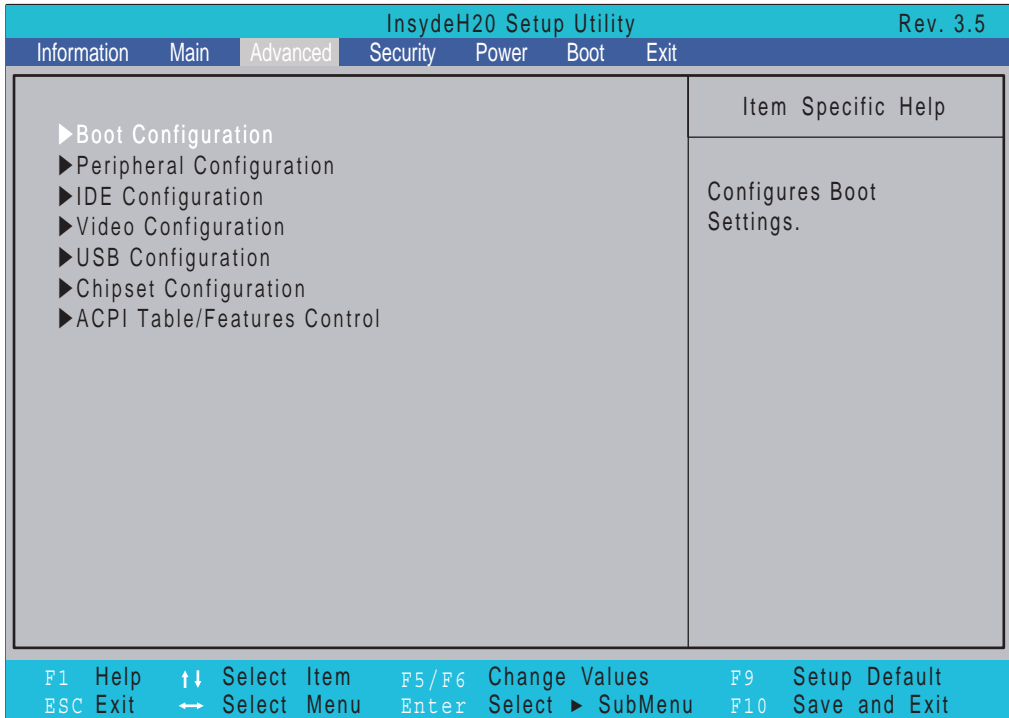

The table below describes the items, menus, and submenus in this screen. Settings in **boldface** are the default and suggested parameter settings.

Parameter	Description	Submenu Items
Boot Configuration	Enter the Boot Configuration menu.	<ul style="list-style-type: none"> Numlock
Peripheral Configuration	Enter the Peripheral Configuration menu.	<ul style="list-style-type: none"> Azalia
IDE Configuration	Enter the IDE Configuration menu.	<ul style="list-style-type: none"> IDE Controller HDC Configure as Channel 1 to 4 Master and Slave
Video Configuration	Enter the Video Configuration menu.	<ul style="list-style-type: none"> IGD—Device2, Function1 IGD—Pre-allocat Memory IGD—DVMT Size
USB Configuration	Enter the USB Configuration menu.	<ul style="list-style-type: none"> USB 2.0 USB Legacy
Chipset Configuration	Enter the Chipset Configuration menu.	<ul style="list-style-type: none"> Energy Lake
ACPI Table/Features Control	Enter the ACPI Table/Features Control menu.	<ul style="list-style-type: none"> FACP—C2 Latency Value FACP—C3 Latency Value FACP—RTC S4 Wakeup APIC—IO APIC Mode HPET—HPET Support <ul style="list-style-type: none"> Base Address select

Security

The Security screen contains parameters that help safeguard and protect your computer from unauthorized use.

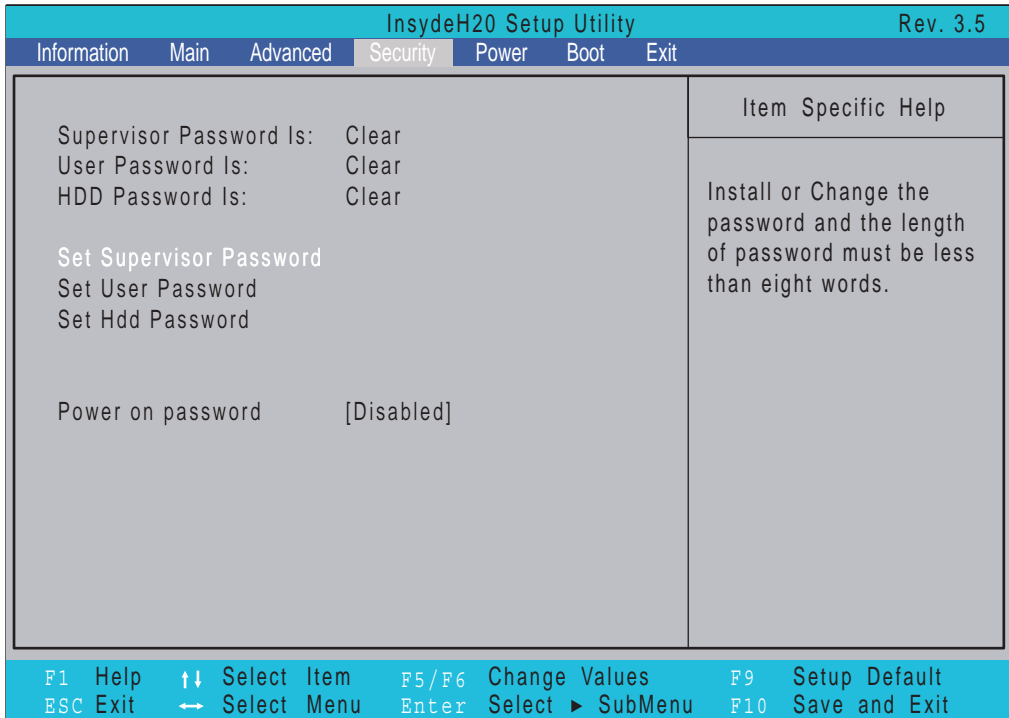

The table below describes the parameters in this screen. Settings in **boldface** are the default and suggested parameter settings.

Parameter	Description	Option
Supervisor Password Is	Shows the setting of the Supervisor password	Clear or Set
User Password Is	Shows the setting of the user password.	Clear or Set
Set Supervisor Password	Press Enter to set the supervisor password. When set, this password protects the BIOS Setup Utility from unauthorized access. The user can not either enter the Setup menu nor change the value of parameters.	
Set User Password	Press Enter to set the user password. When user password is set, this password protects the BIOS Setup Utility from unauthorized access. The user can enter Setup menu only and does not have right to change the value of parameters.	
Set Hdd Password	Enter HDD password.	
Power on password	Defines whether a password is required or not while the events defined in this group happened. The following sub-options are all requires the Supervisor password for changes and should be grayed out if the user password was used to enter setup.	Enabled or Disabled

NOTE: When you are prompted to enter a password, you have three tries before the system halts. Don't forget your password. If you forget your password, you may have to return your notebook computer to your dealer to reset it.

Setting a Password

Follow these steps as you set the user or the supervisor password:

1. Use the ↑ and ↓ keys to highlight the Set Supervisor Password parameter and press the **Enter** key. The Set Supervisor Password box appears:

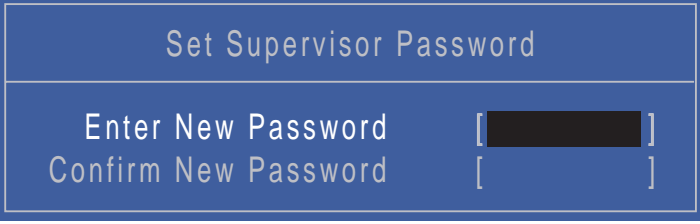

Set Supervisor Password	
Enter New Password	[██████████]
Confirm New Password	[]

2. Type a password in the “Enter New Password” field. The password length can not exceeds 8 alphanumeric characters (A-Z, a-z, 0-9, not case sensitive). Retype the password in the “Confirm New Password” field.

IMPORTANT: Be very careful when typing your password because the characters do not appear on the screen.

3. Press **Enter**. After setting the password, the computer sets the User Password parameter to “Set”.
4. If desired, you can opt to enable the Password on boot parameter.
5. When you are done, press F10 to save the changes and exit the BIOS Setup Utility.

Removing a Password

Follow these steps:

1. Use the ↑ and ↓ keys to highlight the Set Supervisor Password parameter and press the **Enter** key. The Set Password box appears:



Set Supervisor Password	
Enter Current Password	[██████████]
Enter New Password	[]
Confirm New Password	[]

2. Type the current password in the Enter Current Password field and press **Enter**.
3. Press **Enter** twice **without** typing anything in the Enter New Password and Confirm New Password fields. The computer then sets the Supervisor Password parameter to “Clear”.
4. When you have changed the settings, press u to save the changes and exit the BIOS Setup Utility.

Changing a Password

1. Use the ↑ and ↓ keys to highlight the Set Supervisor Password parameter and press the **Enter** key. The Set Password box appears.

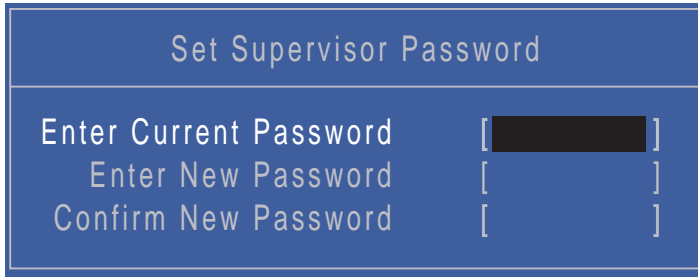

The screenshot shows a blue BIOS screen titled "Set Supervisor Password". It contains three input fields: "Enter Current Password", "Enter New Password", and "Confirm New Password". The first field is filled with blacked-out characters, while the other two are empty.

2. Type the current password in the Enter Current Password field and press **Enter**.
3. Type a password in the Enter New Password field. Retype the password in the Confirm New Password field.
4. Press **Enter**. After setting the password, the computer sets the User Password parameter to "Set".
5. If desired, you can enable the Password on boot parameter.
6. When you are done, press **F10** to save the changes and exit the BIOS Setup Utility.

If the verification is OK, the screen will display as following.

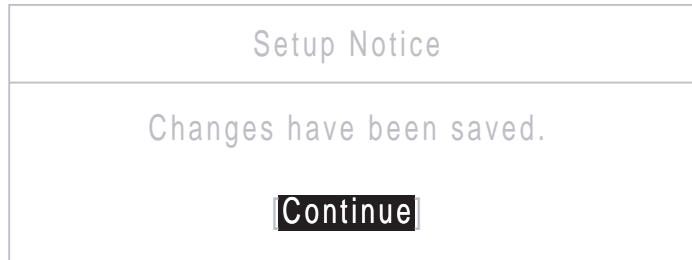

The screenshot shows a white BIOS screen titled "Setup Notice". The text "Changes have been saved." is displayed in the center. At the bottom, there is a black button labeled "Continue".

The password setting is complete after the user presses **Enter**.

If the current password entered does not match the actual current password, the screen will show you the Setup Warning.



The screenshot shows a white BIOS screen titled "Setup Warning" in red text. Below the title, the message "Invalid Password." is displayed in red. At the bottom, there is a black button labeled "Continue".

If the new password and confirm new password strings do not match, the screen displays the following message.



The screenshot shows a white BIOS screen titled "Setup Warning" in red text. Below the title, the message "Passwords do not match. Re-enter password." is displayed in red. At the bottom, there is a black button labeled "Continue".

Power

The Power screen allows the user to configure CPU and power management options.

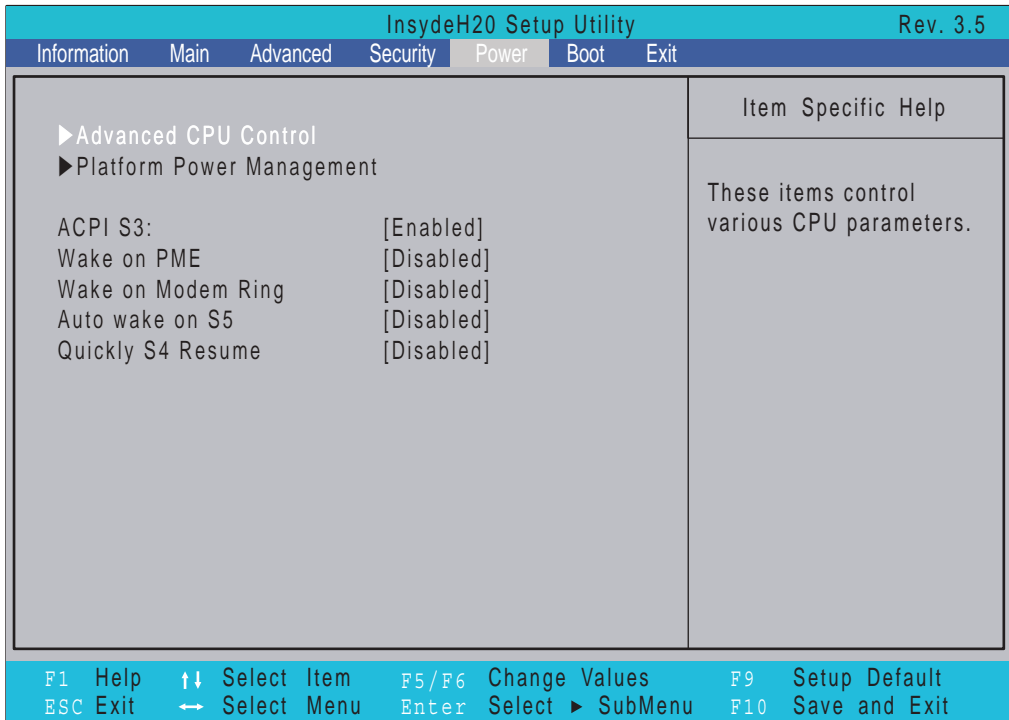

The table below describes the parameters in this screen. Settings in **boldface** are the default and suggested parameter settings.

Parameter	Description	Submenu Items
Advanced CPU Control	Enter the Advanced CPU Control menu.	<ul style="list-style-type: none"> • IST Configuration • Thermal Mode • CMP Support • Use NX capability • C-State support • Enhanced C-States Enable • Pop Up Support • Pop Down Support • Hard C4E • Bi-directional PROCHOT# • ACPI 3.0 T-States • DTS Enable • Thermal Trip Points Setting (Throttle On Temp.)
Platform Power Management	Enter the Platform Power Management menu.	<ul style="list-style-type: none"> • PCI Clock Run • _CST - C4 Latency Value
ACPI S3	Enable or Disable ACPI S1/S3 Sleep State.	N/A
Wake on PME	Disable or Enable wake up when the system power is off and a PCI Power Management Enable wake up event occurs.	N/A
Wake on Modem Ring	Disable or Enable wake up when the system power is off and a modem attached to the serial port is ringing.	N/A

Parameter	Description	Submenu Items
Auto wake on S5	Disable or Enable auto wake up by date and time or at a fixed time everyday.	N/A
Quickly S4 Resume	Disable or Enable optional quick boot from S4 Resume.	N/A

Boot

This menu allows the user to decide the order of boot devices to load the operating system. Bootable devices includes the USB diskette drives, the onboard hard disk drive and the DVD drive in the module bay.

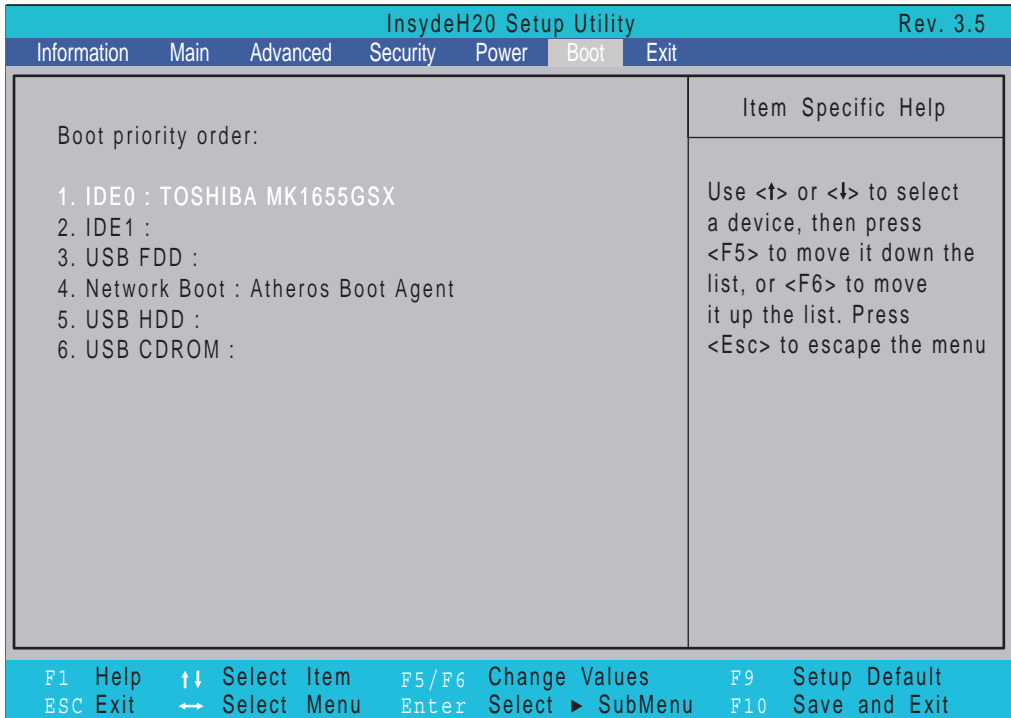

Exit

The Exit screen allows you to save or discard any changes you made and quit the BIOS Utility.

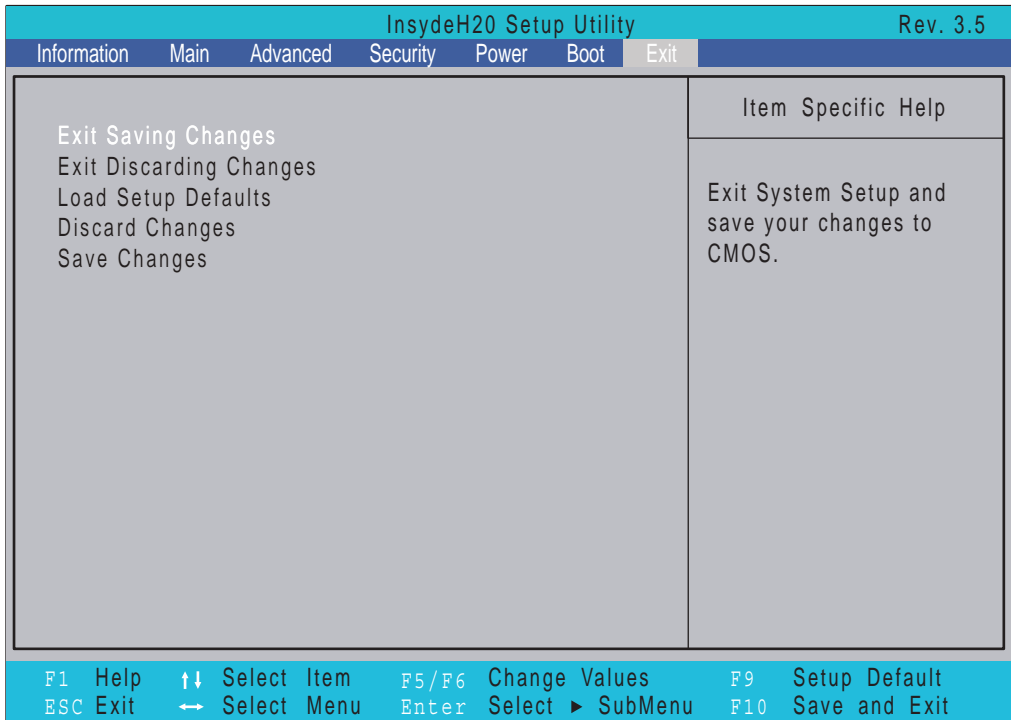

The table below describes the parameters in this screen.

Parameter	Description
Exit Saving Changes	Exit System Setup and save your changes to CMOS.
Exit Discarding Changes	Exit utility without saving setup data to CMOS.
Load Setup Default	Load default values for all SETUP item.
Discard Changes	Load previous values from CMOS for all SETUP items.
Save Changes	Save Setup Data to CMOS.

BIOS Flash Utility

The BIOS flash memory update is required for the following conditions:

- New versions of system programs
- New features or options
- Restore a BIOS when it becomes corrupted.

Use the Phlash utility to update the system BIOS flash ROM.

NOTE: If you do not have a crisis recovery diskette at hand, then you should create a **Crisis Recovery Diskette** before you use the Phlash utility.

NOTE: Do not install memory-related drivers (XMS, EMS, DPMI) when you use the Phlash.

NOTE: Please use the AC adaptor power supply when you run the Phlash utility. If the battery pack does not contain enough power to finish BIOS flash, you may not boot the system because the BIOS is not completely loaded.

Follow the steps below to run the Phlash.

1. Prepare a bootable diskette.
2. Copy the flash utilities to the bootable diskette.
3. Then boot the system from the bootable diskette. The flash utility has auto-execution function.

DOS Flash Utility

Perform the following steps to use the DOS Flash Utility:

1. Press F2 during boot to enter the Setup Menu.
2. Select **Boot Menu** to modify the boot priority order, for example, if using USB HDD to Update BIOS, move USB HDD to position 1.

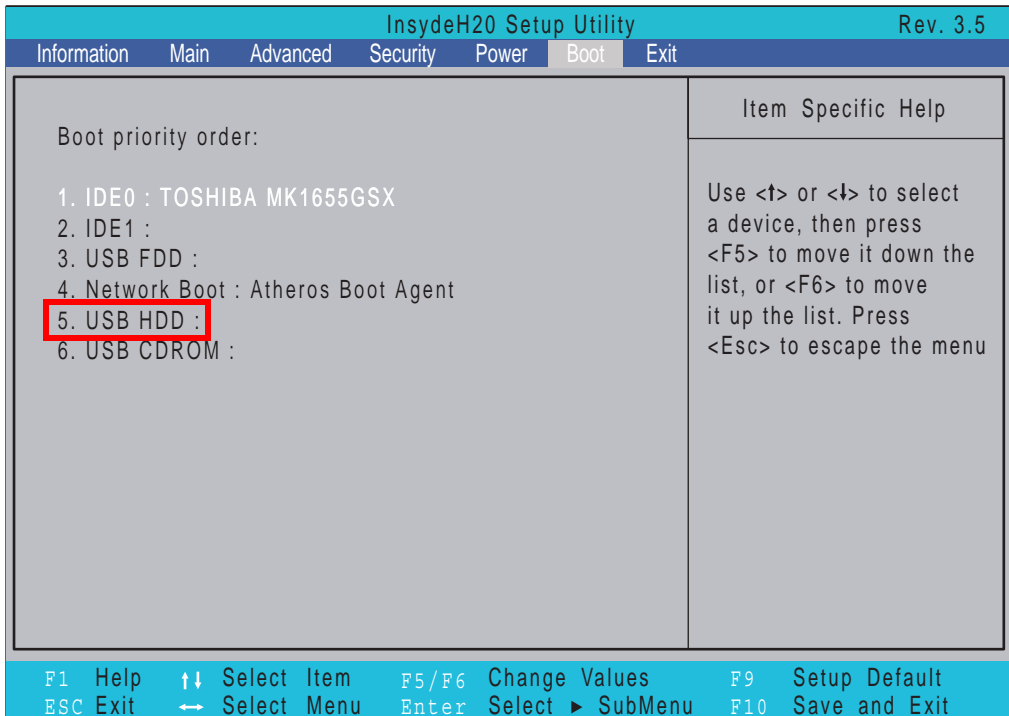

3. Execute the **FLASH.BAT** batch file to update BIOS.

The flash process begins as shown.



4. In flash BIOS, the message **Please do not remove AC Power Source** displays.

NOTE: If the AC power is not connected, the following message displays.



Plug in the AC power to continue.

-
5. Flash is complete when the message Flash programming complete displays.

WinFlash Utility

Perform the following steps to use the WinFlash Utility:

1. Double click the WinFlash executable.
2. Click **OK** to begin the update. A progress screen displays.



3. When the process is complete, close all programs and applications and reboot the system.

Remove HDD/BIOS Password Utilities

This section provide you with removing HDD/BIOS method:

Remove HDD Password:

When the user keys in the wrong password three times, the system reports the following error code to user.

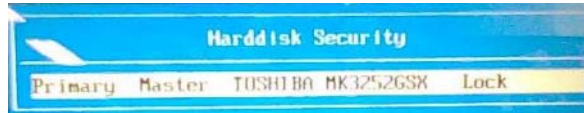

To unlock the HDD password, perform the following steps:

1. Press **Enter** to display the Select Item screen.

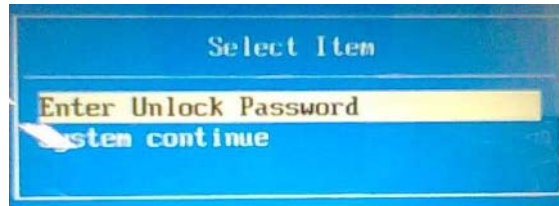

2. Select **Enter Unlock Password** and press **Enter**.

An Unlock Password displays.



3. Make a note of the key, **76943488** in the example.
4. Boot up the system and open a DOS prompt.
5. Enter the **UnlockHD.EXE** command and input the key to create an unlock code. Make a note of the result, for example **46548274**.
6. Reboot and enter the BIOS by pressing F2 when prompted.
7. Go to the Security menu and select Set Hdd Password.



8. Enter the unlock code generated by UnlockHD.EXE as the current password, **46548274** in the example, and complete the **New Password** and **Confirm** fields to create a new HDD password.
9. Save and exit the BIOS to complete the process.

Removing BIOS Passwords:

If you key in the wrong Supervisor Password three times, System Disabled displays on the screen. See the image below.

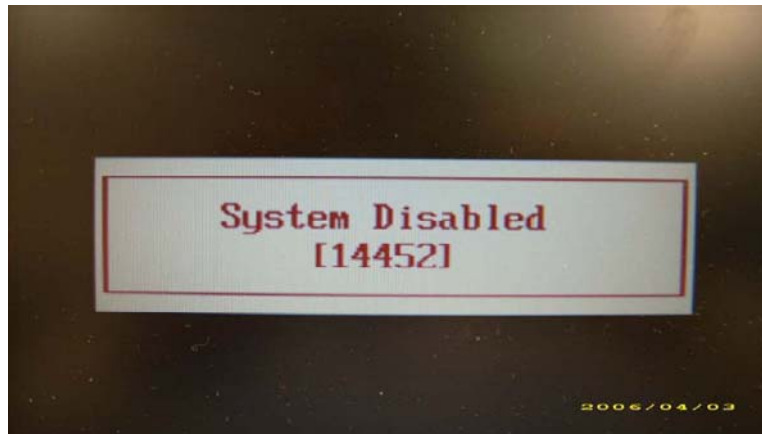

To reset the BIOS password, run BIOS_PW.EXE as follows:

1. Key in **bios_pw 14452 0**
2. Select one string from the list.

```
C:\WINDOWS\system32\cmd.exe
Microsoft Windows XP [Version 5.1.2600]
(C) Copyright 1985-2001 Microsoft Corp.
C:\Documents and Settings\M54>d:
D:\>bios_pw 14452 0
unlock6.exe v1.0 1 July 1997
qj119900
0?yqmjd
c.jl14tm
6mbzjaj
D:\>
```

3. Reboot the system and key in the selected string (qjgg9vy, 07yqmjd etc.) for the BIOS user password.



Cleaning BIOS Passwords

To clear the password, perform the following steps:

1. From a DOS prompt, Execute **clnpwd.exe**

```
d:\Clnpwd>clnpwd
ACER Clean Password Utility V1.00
Press 1 or 2 to clean any password shown as below
  1.User Password
  2.Supervisor Password

Clean User Password Successfully!
```

2. Press 1 or 2 to clean the desired password shown on the screen.

The onscreen message determines whether the function is successful or not.

Miscellaneous Utilities

Using Boot Sequence Selector

Boot Sequence Selector allows the boot order to be changes without accessing the BIOS. To use Boot Sequence Selector, perform the following steps:

1. Enter into DOS.
2. Execute BS.exe to display the usage screen.

```
d:\B00TSEQ>bs
*** Boot Sequence Selector Version 0.03 ***
Create by Rockwell Chuang 10/01/2005.
Usage:
      BS [ 1 | 2 | 3 | 4 ]
BS 1 : [ Floppy ] => [ HardDisk ] => [ CD-ROM ] => [ LAN   ]
BS 2 : [ HardDisk ] => [ CD-ROM ] => [ LAN   ] => [ Floppy ]
BS 3 : [ CD-ROM ] => [ HardDisk ] => [ LAN   ] => [ Floppy ]
BS 4 : [ LAN   ] => [ Floppy ] => [ HardDisk ] => [ CD-ROM ]
d:\B00TSEQ>
```

3. Select the desired boot sequence by entering the corresponding sequence, for example, enter BS2 to change the boot sequence to HDD|CD ROM|LAN|Floppy.

Using DMITools

The DMI (Desktop Management Interface) Tool copies BIOS information to eeprom to be used in the DMI pool for hardware management.

When the BIOS displays **Verifying DMI pool data** it is checking the table correlates with the hardware before sending to the operating system (Windows, etc.).

To update the DMI Pool, perform the following steps:

1. Enter into DOS.
2. Execute **dmitools.exe**. The following messages show dmitools usage:

```
*** Compal DMI String R/W Utility Ver1.40 for 2006/03/14 ***

Usage:

DMITOOLS [ /R | /WP | /WS | /WU ] [ STRING ]

[R]   : Read DMI Information from Memory
[WM]  : Write Manufacturer Name to EEPROM. (Max.= 16 characters)
[WP]  : Write Product Name to EEPROM.      (Max.= 16 characters)
[WS]  : Write Serial Number to EEPROM     (Max.= 22 characters)
[WU]  : Write UUID to EEPROM.             (Ignore String   )
[WA]  : Write Asset Tag to EEPROM.        (Max.= 32 characters)
```

IMPORTANT:The following write examples (2 to 5) require a system reboot to take effect

Example 1: Read DMI Information from Memory

Input:

```
dmitools /r
```

Output:

```
Manufacturer (Type1, Offset04h): Acer  
Product Name (Type1, Offset05h): Aspire one xxxxx  
Serial Number (Type1, Offset07h): 01234567890123456789  
UUID String (Type1, Offset08h): xxxxxxxx-xxxx-xxxx-xxxx-xxxxxxxxxxxx  
Asset Tag (Type3, Offset04h): Acer Asstag
```

Example 2: Write Product Name to EEPROM

Input:

```
dmitools /wp Acer
```

Example 3: Write Serial Number to EEPROM

Input:

```
dmitools /ws 01234567890123456789
```

Example 4: Write UUID to EEPROM

Input:

```
dmitools /wu
```

Example 5: Write Asset Tag to EEPROM

Input:

```
dmitools /wa Acer Asstag
```

Using the LAN MAC Utility

Perform the following steps to write MAC information to eeprom:

1. Use a text editor, for example Notepad, to edit the MAC.CFG file as shown:

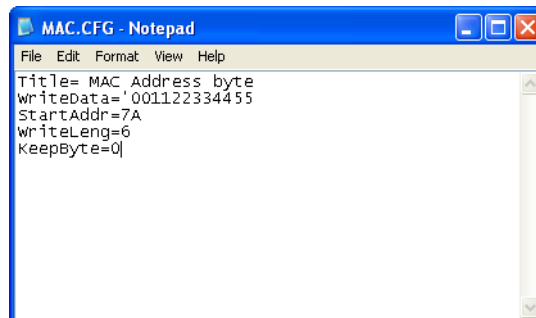

- WriteData= '001122334455' <----- MAC value
 - StartAddr=7A <----- MAC address
 - WriteLeng=6 <----- MAC value length
 - KeepByte=0 <----- can be any value
2. Boot into DOS.
 3. Execute **MAC.BAT** to write MAC information to eeprom.

Machine Disassembly and Replacement

This chapter contains step-by-step procedures on how to disassemble the notebook computer for maintenance and troubleshooting.

Disassembly Requirements

To disassemble the computer, you need the following tools:

- Wrist grounding strap and conductive mat for preventing electrostatic discharge
- Flat screwdriver
- Philips screwdriver
- Plastic flat screwdriver
- Plastic tweezers

NOTE: The screws for the different components vary in size. During the disassembly process, group the screws with the corresponding components to avoid mismatch when putting back the components.

Related Information

The product previews seen in the disassembly procedures may not represent the final product color or configuration.

IMPORTANT: Cable paths and positioning may not represent the actual model. During the removal and replacement of components, ensure all available cable channels and clips are used and that the cables are replaced in the same position.

General Information

Pre-disassembly Instructions

Before proceeding with the disassembly procedure, make sure that you do the following:

1. Turn off the power to the system and all peripherals.
2. Unplug the AC adapter and all power and signal cables from the system.



3. Place the system on a flat, stable surface.
4. Remove the battery pack.

Disassembly Process

The disassembly process is divided into the following sections:

- External components disassembly
- Main unit disassembly
- LCD module disassembly

The flowcharts provided in the succeeding disassembly sections illustrate the entire disassembly sequence. Observe the order of the sequence to avoid damage to any of the hardware components. For example, if you want to remove the Mainboard, you must first remove the Keyboard, and LCD Module then disassemble the inside assembly frame in that order.

Main Screw List

Screw	Quantity	Part Number
M2*3	16	86.S5502.001
M2*6	21	86.S5502.002
M3*3	4	86.S5502.003

External Module Disassembly Process

External Modules Disassembly Flowchart

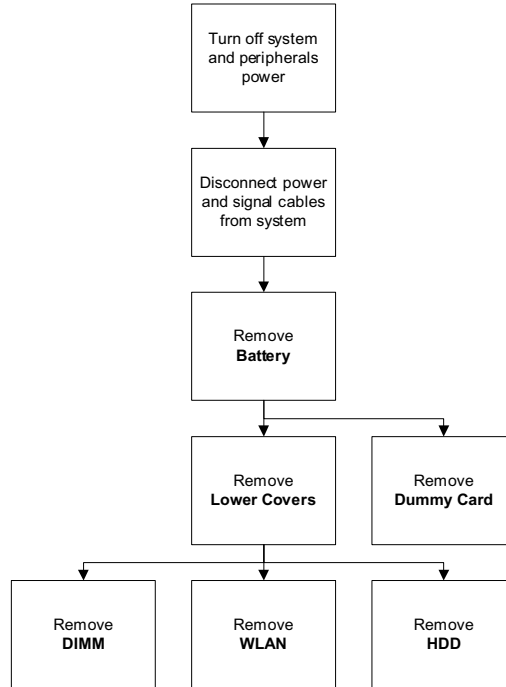

Screw List

Step	Screw	Quantity	Part No.
Lower Covers	M2*6	2	86.S5502.002
HDD Carrier	M3*3	4	86.S5502.003
WLAN Module	M2*3	1	86.S5502.001

Removing the Battery Pack

1. Turn the computer over.
2. Slide the battery lock/unlock latch to the unlock position.



3. Slide and hold the battery release latch to the release position (1), then slide out the battery pack from the main unit (2).

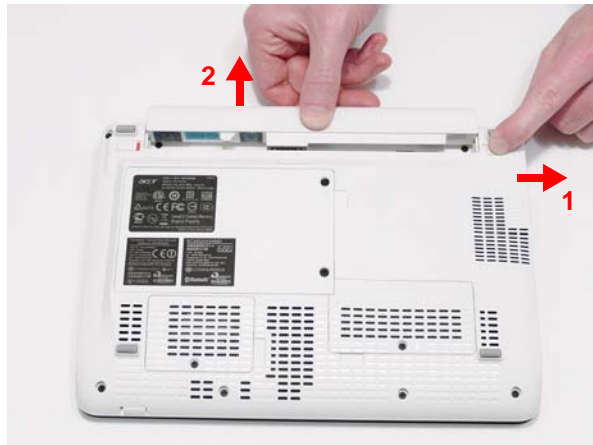

Removing the SD Dummy Card

1. Push the SD dummy card all the way in to eject it.





2. Pull the card out from the slot.

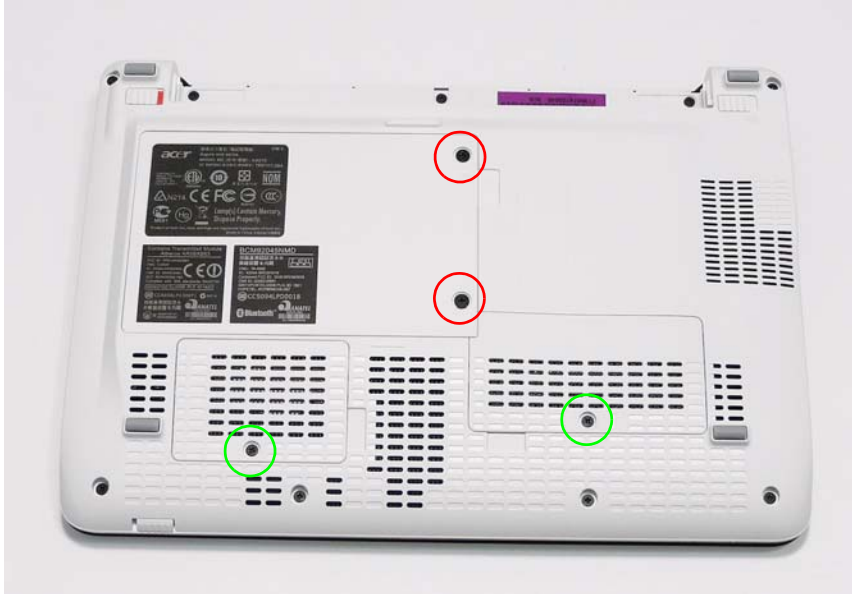

Removing the Lower Covers

1. See "Removing the Battery Pack" on page 42.
2. Loosen the two captive screws in the HDD cover (red callout) and remove the two screws from the Memory and WLAN covers (green callout).



Step	Size	Quantity	Screw Type
Lower Covers (green callout)	M2*6	2	

3. Lift the HDD cover up to remove.



4. Lift the Memory cover up to remove.

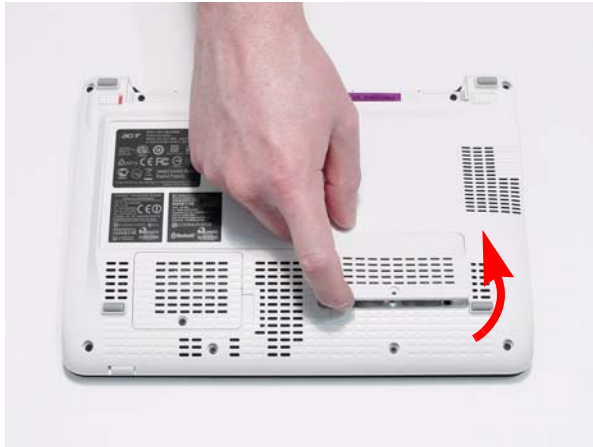

5. Lift the WLAN cover up to remove.

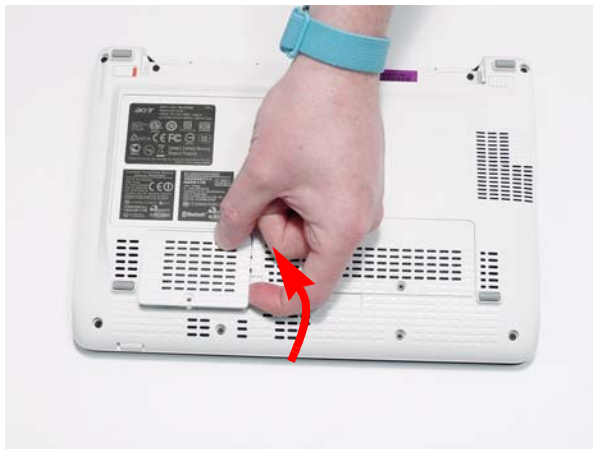

Removing the Hard Disk Drive Module

1. See “Removing the Lower Covers” on page 44.
2. Use the pull-tab to disconnect the HDD from the interface connector.

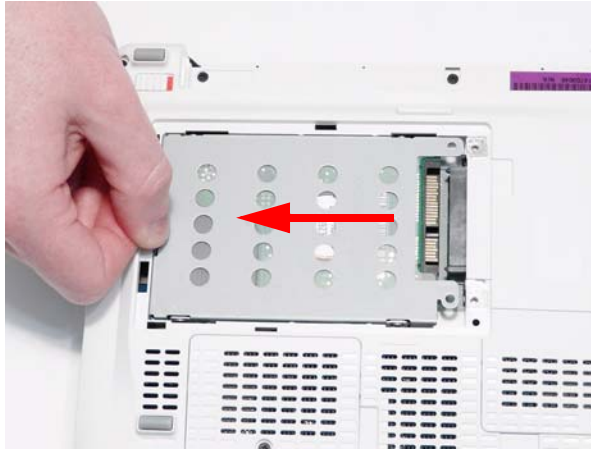



3. Lift the hard disk drive module out of the bay.

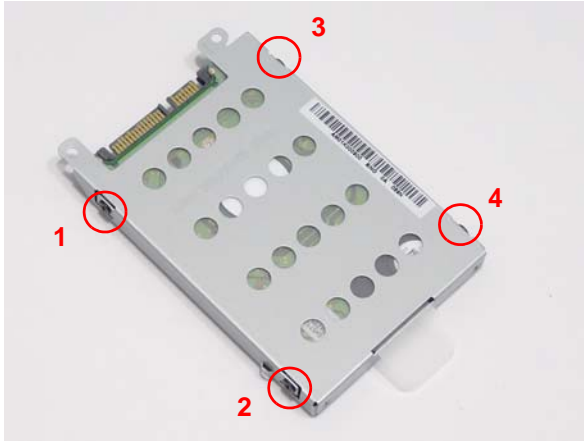

NOTE: To prevent damage to device, avoid pressing down on it or placing heavy objects on top of it.

4. Remove the four screws securing the hard disk to the carrier in reverse numerical order, from 4 to 1.



Step	Size	Quantity	Screw Type
HDD Carrier	M3*3	4	

5. Remove the HDD from the carrier.

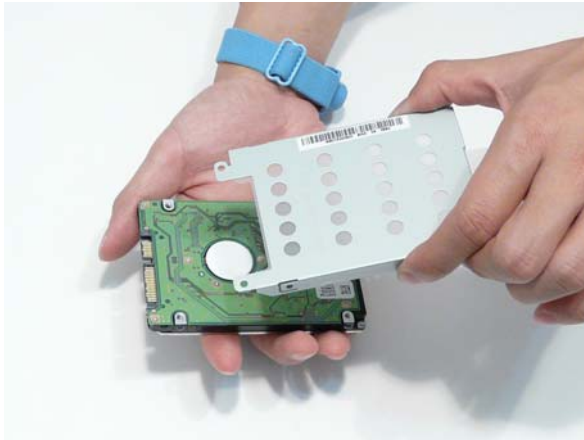

Removing the DIMM Module

1. See “Removing the Lower Covers” on page 44.
2. Push out the release latches on both sides of the DIMM socket to release the DIMM module.

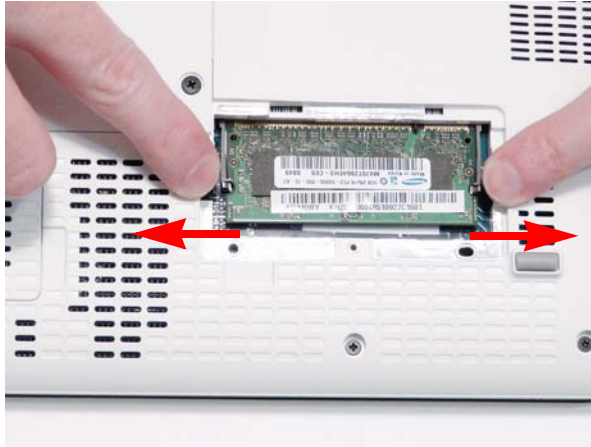

3. Remove the DIMM module.

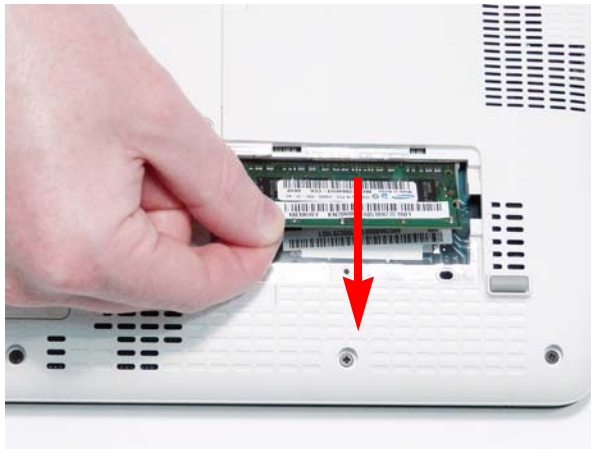

Removing the WLAN Module

1. See “Removing the Lower Covers” on page 44.
2. Remove the adhesive tape securing the cables in place.



3. Disconnect the antenna cables from the WLAN board.

IMPORTANT:The black cable attaches to the MAIN (J3) terminal and the gray cable attaches to the AUX (J2) terminal.



4. Move the antenna away and remove the single screw on the WLAN board.



Step	Size	Quantity	Screw Type
WLAN Module	M2*3	1	

5. Detach the WLAN board from the WLAN socket.

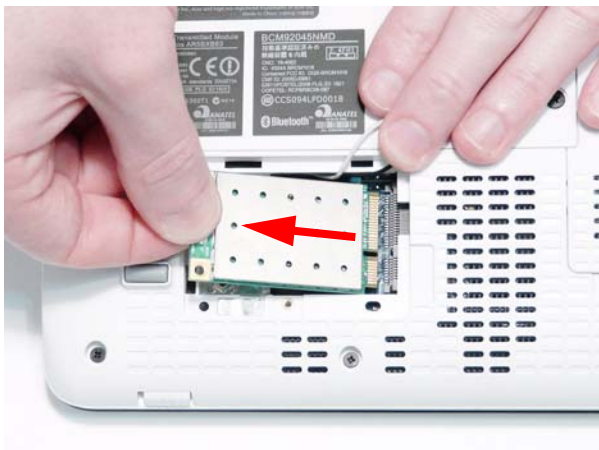

NOTE: When reattaching the antennas, ensure the cables are tucked into the chassis to prevent damage.

Main Unit Disassembly Process

IMPORTANT: Cable paths and positioning may not represent the actual model. During the removal and replacement of components, ensure all available cable channels and clips are used and that the cables are replaced in the same position.

Main Unit Disassembly Flowchart

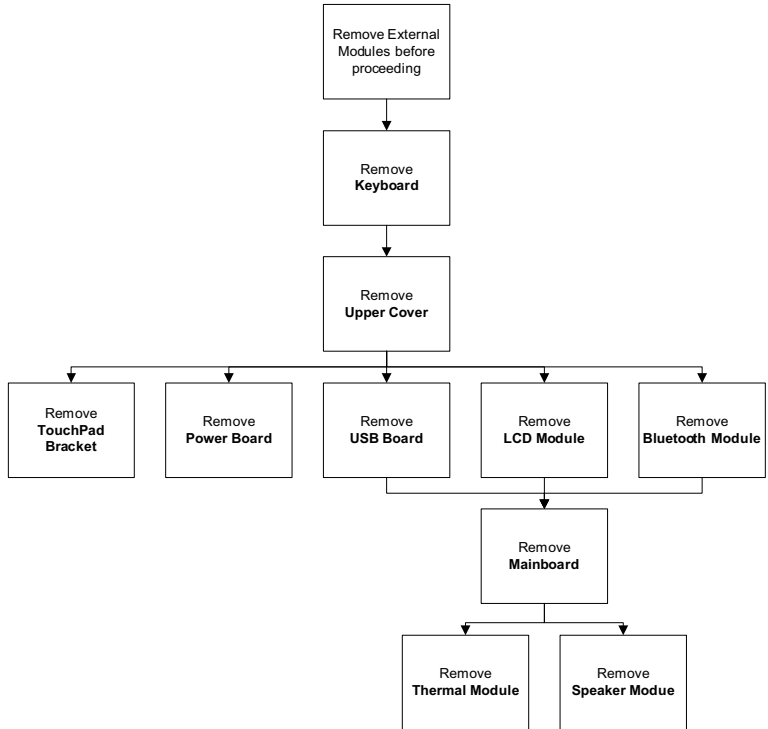

Screw List

Step	Screw	Quantity	Part No.
Upper Cover	M2*3	3	86.S5502.001
	M2*6	11	86.S5502.002
Power Board	M2*3	1	86.S5502.001
TouchPad Bracket	M2*3	1	86.S5502.001
LCD Module	M2*6	2	86.S5502.002
USB Board	M2*3	1	86.S5502.001
Mainboard	M2*3	1	86.S5502.001
Speaker Module	M2*3	2	86.S5502.001
Thermal Module	M2*3	2	86.S5502.001

Removing the Keyboard

1. See "Removing the Battery Pack" on page 42.
2. Turn the computer rightside up and open the lid to the full extent.
3. Unlock the single securing latch above the **F8** key by pressing down with plastic tweezers.

IMPORTANT:The use of metal tools may damage the outer casing. Use plastic tools where available.



4. Grasp the Keyboard and lift upward in the centre as shown.



5. Grasp the Keyboard at both sides as shown, and slide it toward the LCD Panel to release the securing clips.



6. Turn the Keyboard over and place it on the TouchPad area as shown.



7. Lift the Keyboard FFC securing latch as shown.

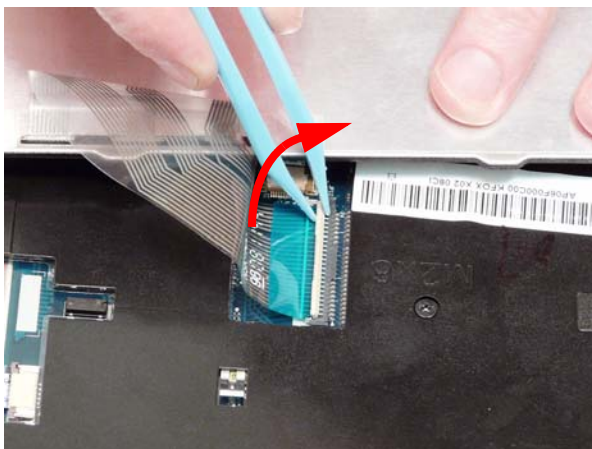



8. Disconnect the FFC and remove the Keyboard.

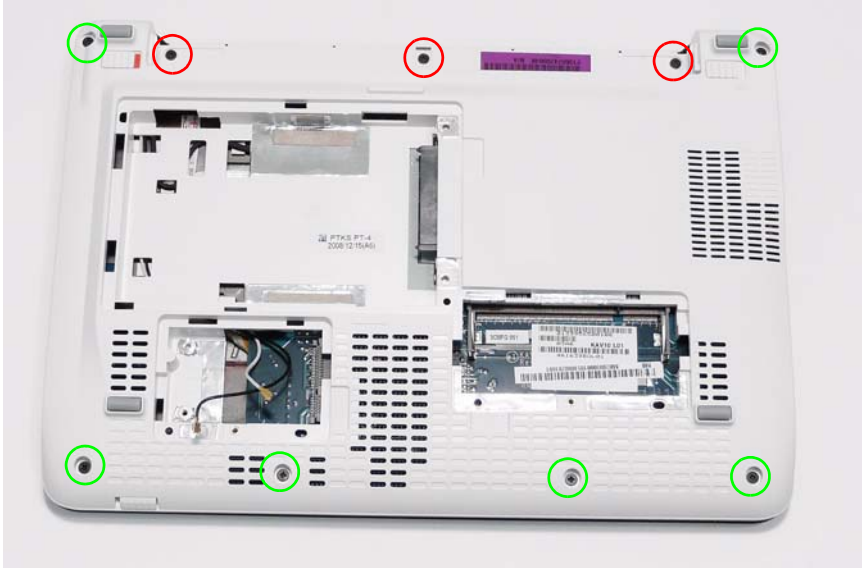

Removing the Upper Cover

1. See "Removing the Lower Covers" on page 44.
2. Turn the computer over. Remove the nine securing screws.



Step	Size	Quantity	Screw Type
Upper Cover (red callouts)	M2*3	3	
Upper Cover (green callouts)	M2*6	6	

3. Turn the computer over and disconnect the following cables from the Mainboard.

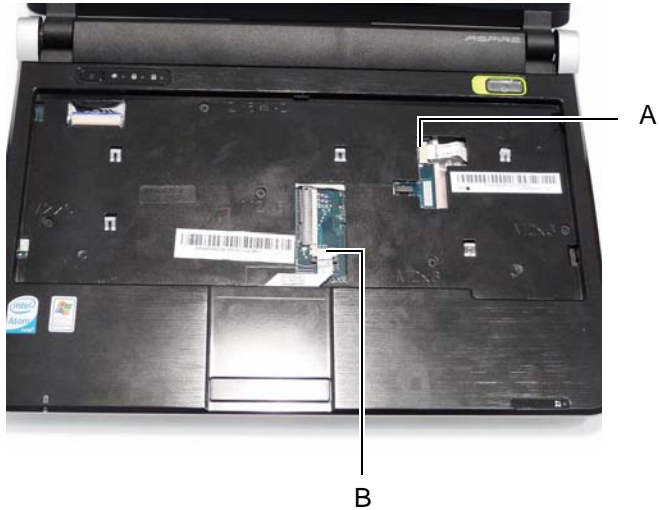

Release the locking latch on A as shown.



Disconnect A from the Mainboard.

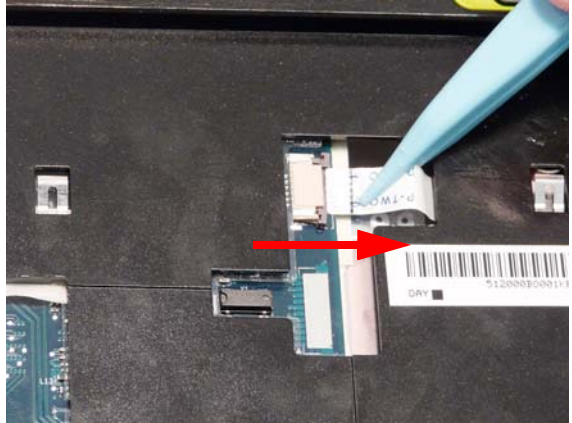

Release the locking latch on B as shown.

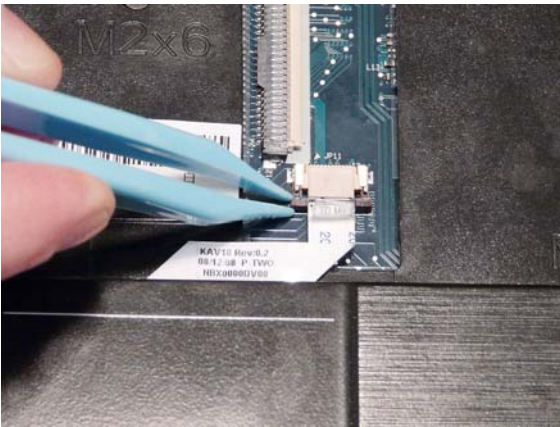

Disconnect B from the Mainboard.

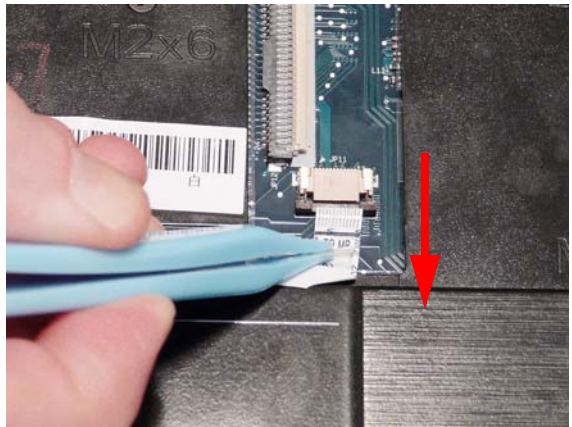

4. Remove the five securing screws from the Upper Cover.

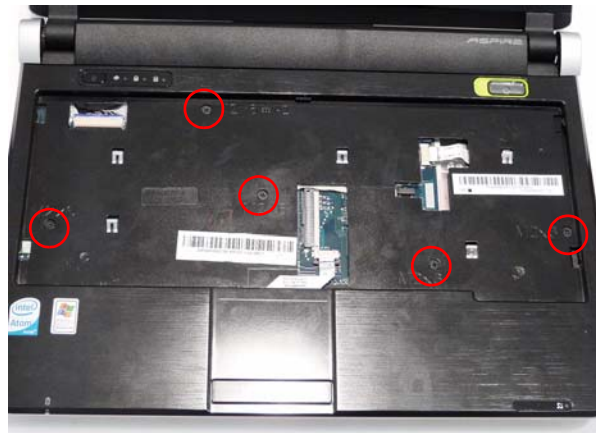

Step	Size	Quantity	Screw Type
Upper Cover	M2*6	5	

5. Grasp the top-right side of the upper cover and pry apart.



6. Work along the top and right sides as shown, gradually prying up the cover.

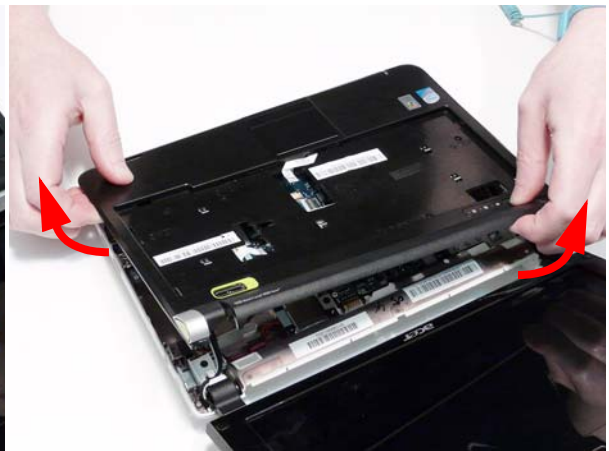

7. Lift the Upper Cover clear of the computer.

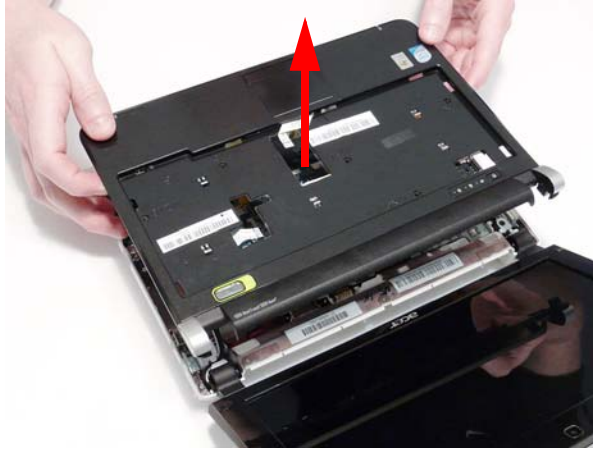

Removing the Power Board

1. See "Removing the Upper Cover" on page 54.
2. Remove the single securing screw from the Power Board.



Step	Size	Quantity	Screw Type
Power Board	M2*3	1	

3. Disconnect the FFC adhesive from the Upper Cover as shown.

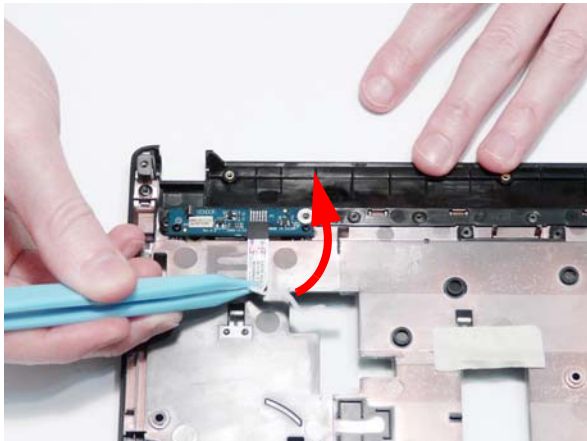

4. Lift up the right side of the Power Board as shown, ensuring that the board is free of the securing pin.

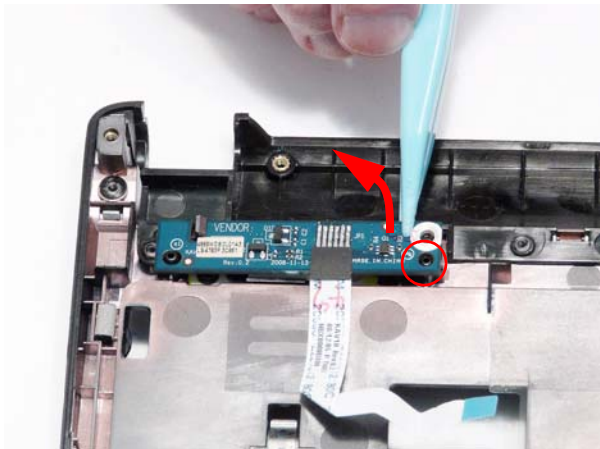

-
5. Grasp the right side of the Power Board as shown and lift the left side of the board to release the left side securing pin.

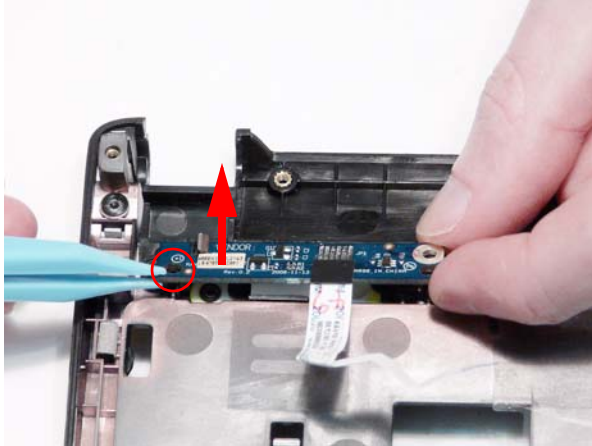

6. Rotate the Power Board as shown to disengage the final securing clip.

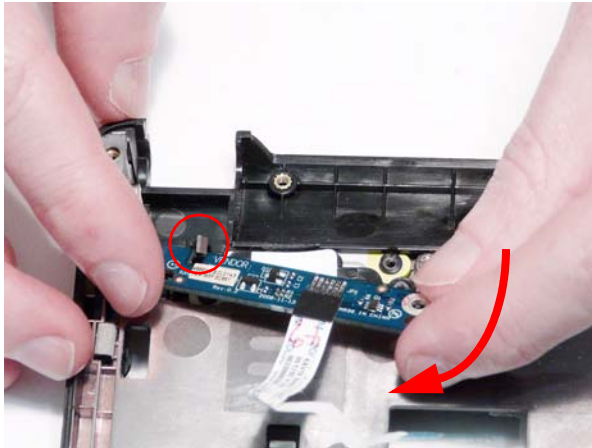

7. Remove the board from the Upper Cover.

Removing the TouchPad Bracket

1. See "Removing the Upper Cover" on page 54.
2. Remove the single securing screw from the TouchPad Bracket.

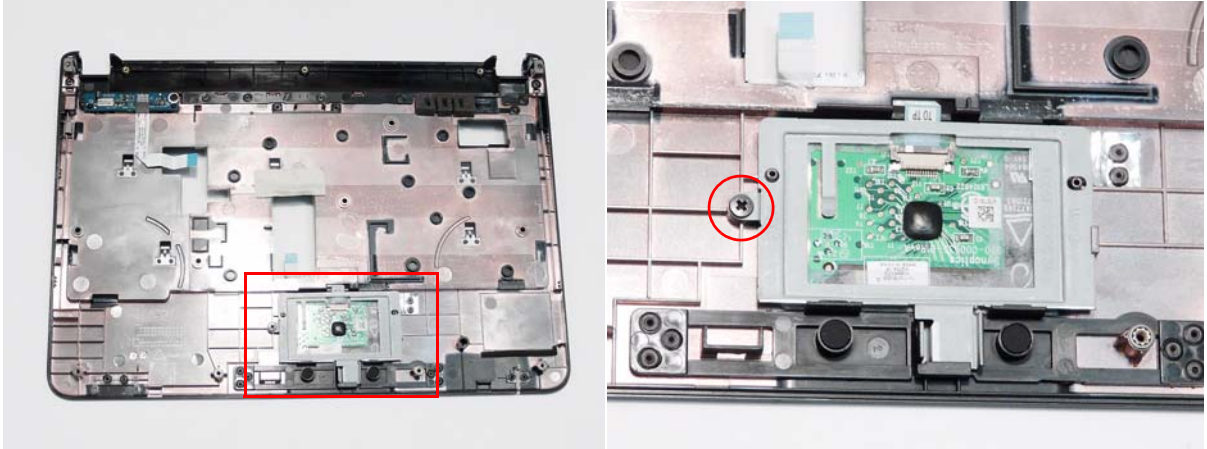

Step	Size	Quantity	Screw Type
TouchPad Bracket	M2*3	1	

3. Lift the left side of the TouchPad Bracket (1) and slide the bracket to the left to clear the securing pin (2).

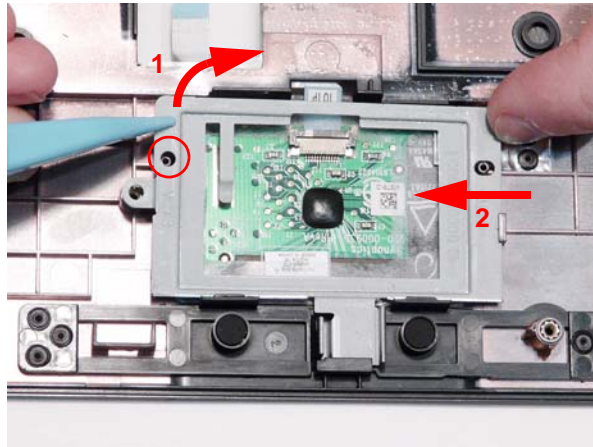

4. Lift the bracket up to clear the right side securing pin.

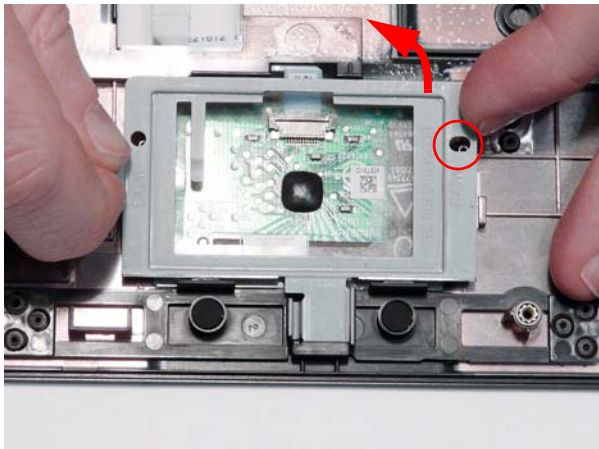

5. Slide the TouchPad Bracket out of the Upper Cover as shown.

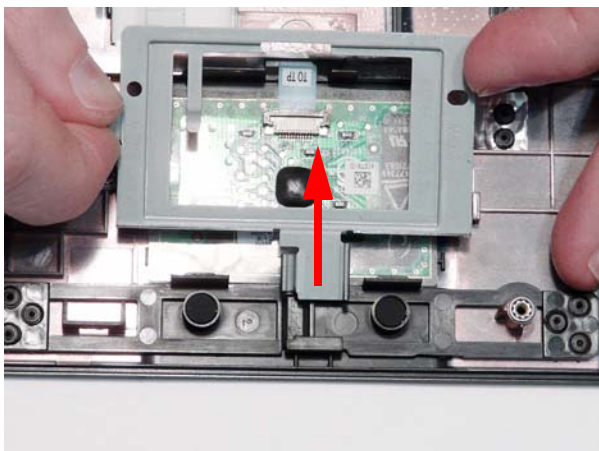

6. Release the FFC locking latch as shown.

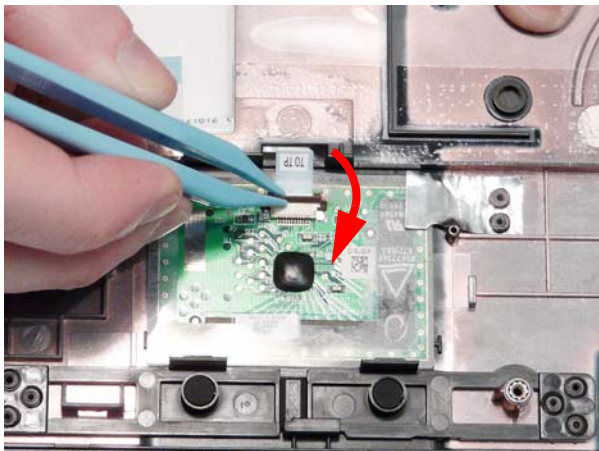

-
7. Grasp the FFC from the underside of the Upper Cover and disconnect it from the TouchPad.
- NOTE:** It may be necessary to disengage the FFC from the adhesive covering on the TouchPad (blue callout).

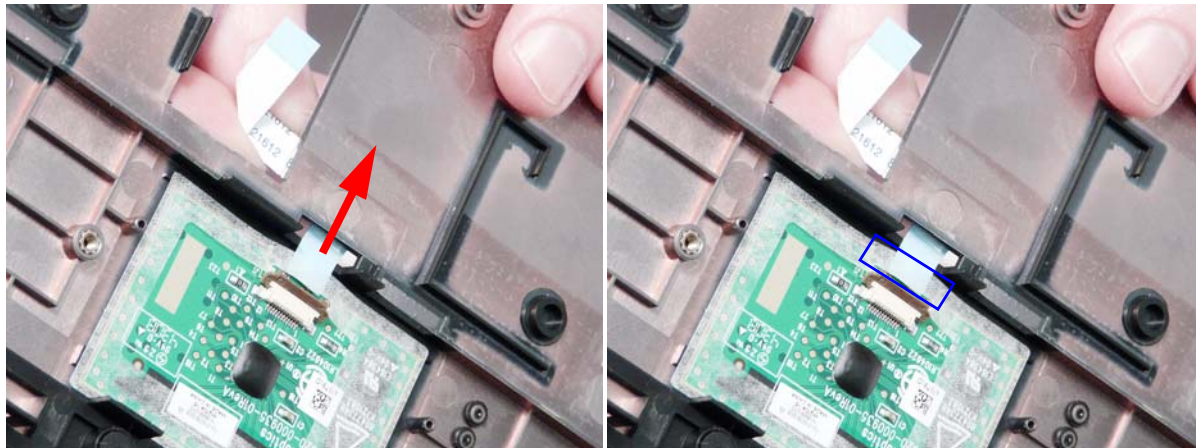

Removing the LCD Module

IMPORTANT: Cable paths and positioning may not represent the actual model. During the removal and replacement of the LCD Module, ensure all available cable channels and clips are used and that the cables are replaced in the same position.

1. See “Removing the Upper Cover” on page 54.
2. Remove the adhesive strip securing the antenna cables in place.

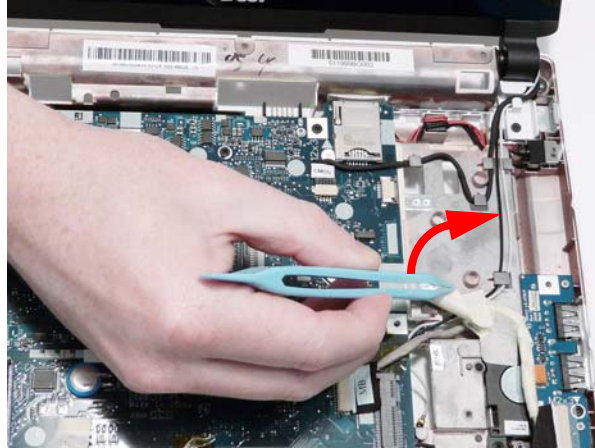

3. Carefully pull the antenna cables through from the underside of the computer and remove the cables from the cable clips.

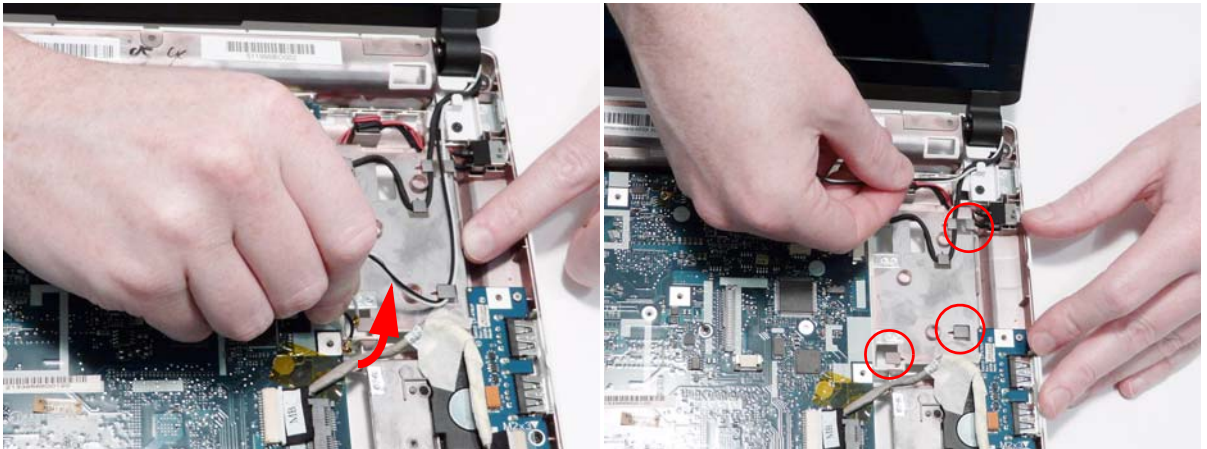

4. Disconnect the Camera cable from the Mainboard.

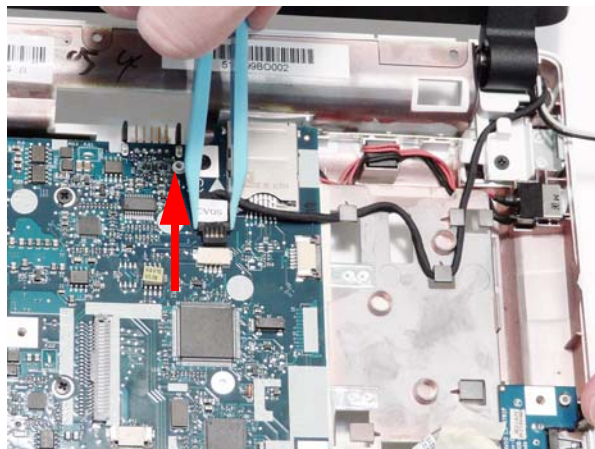

5. Remove the cable from the cable clips.

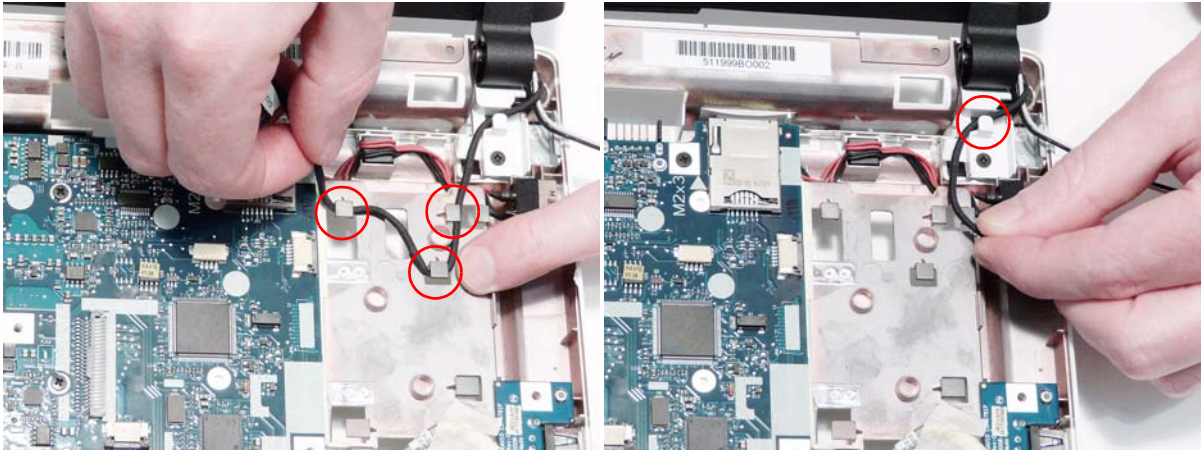

6. Disconnect the LCD power cable from the Mainboard.

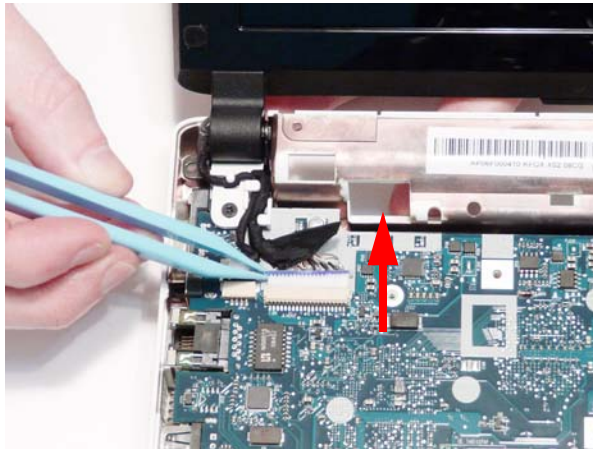

7. Remove the cable from the cable clips.

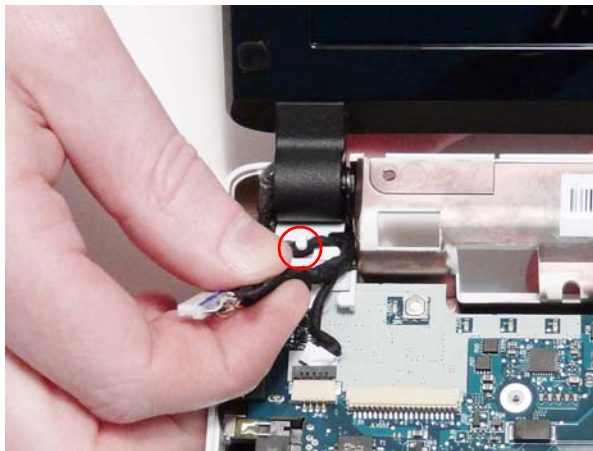

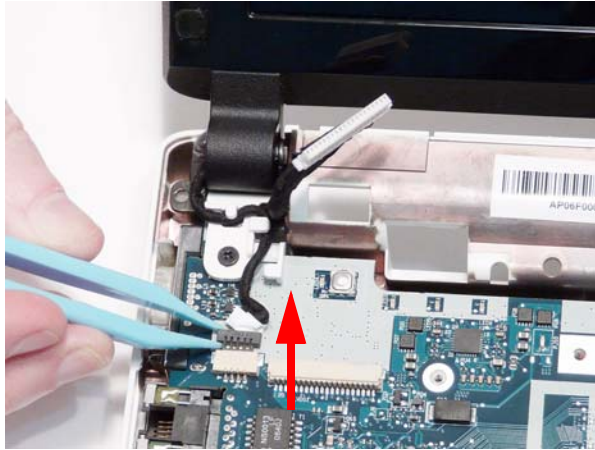

8. Disconnect the MIC cable from the Mainboard.

IMPORTANT:The MIC cable passes under the hinge, not along the same path as the LCD power cable.

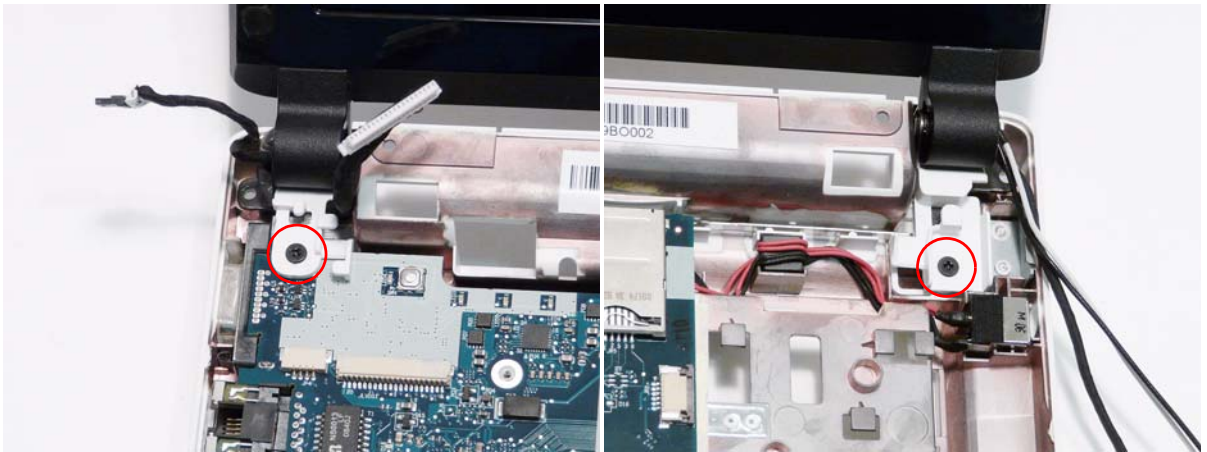

9. Remove the two securing screws from the LCD brackets.



Step	Size	Quantity	Screw Type
LCD Module	M2*6	2	

IMPORTANT:Ensure all cables are clear of the lower cover before removing the LCD module.

10. Grasp the module with both hands and lift upwards.

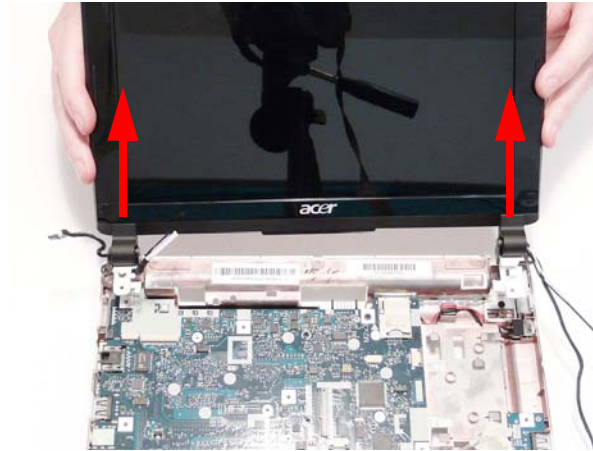

Removing the RTC Battery

IMPORTANT: Follow local regulations for disposal of all batteries.

The RTC Battery is soldered to the Mainboard. To replace the battery, solder the new battery to the connections shown.

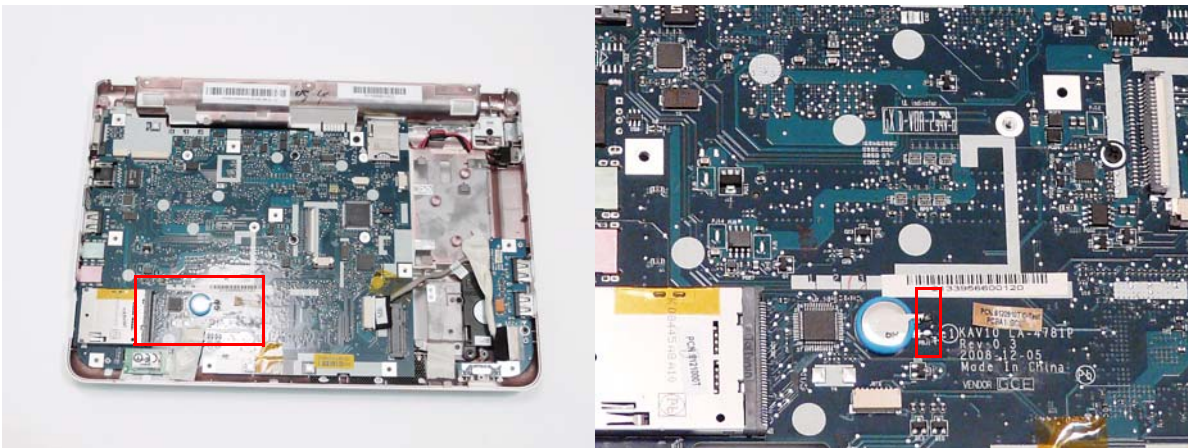

Removing the USB Board and Cable

1. Disconnect the USB cable from the Mainboard.

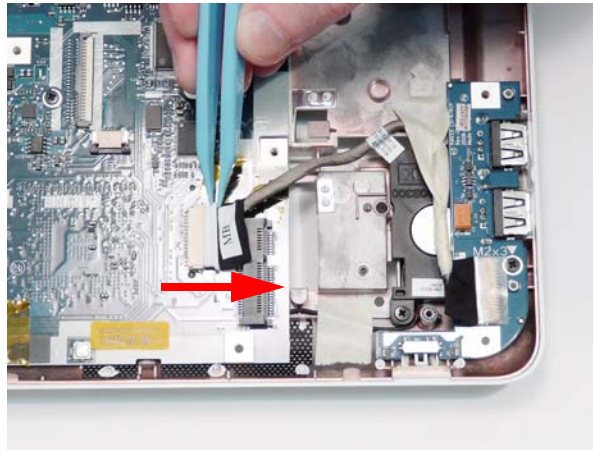

2. Peel back the adhesive strip securing the USB cable and disconnect the cable from the USB Board.

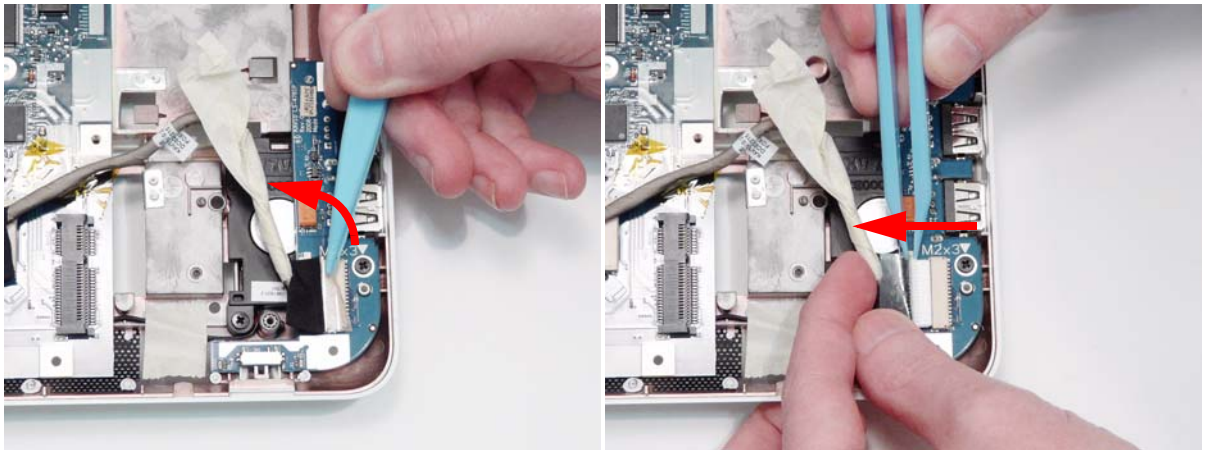

3. Remove the single securing screw from the USB Board.

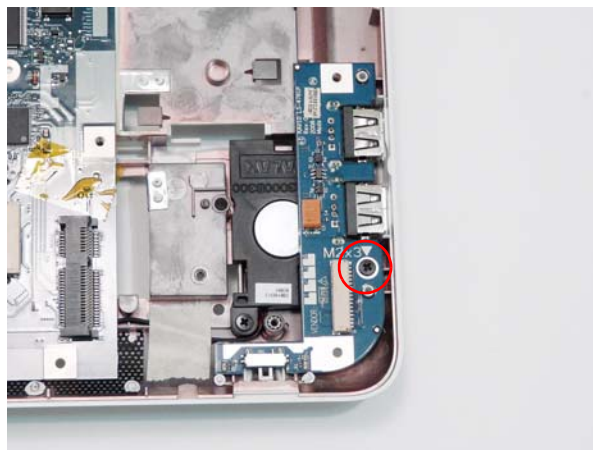

Step	Size	Quantity	Screw Type
USB Board	M2*3	1	

-
4. Lift the USB Board clear of the computer rear edge first.

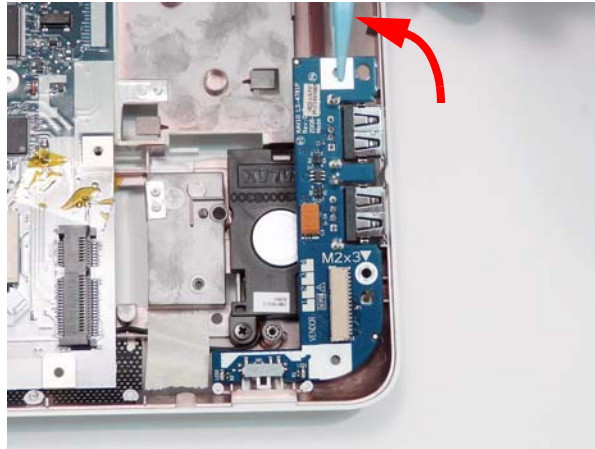

Removing the Bluetooth Module

1. Remove the adhesive tape securing the Bluetooth cable in place.

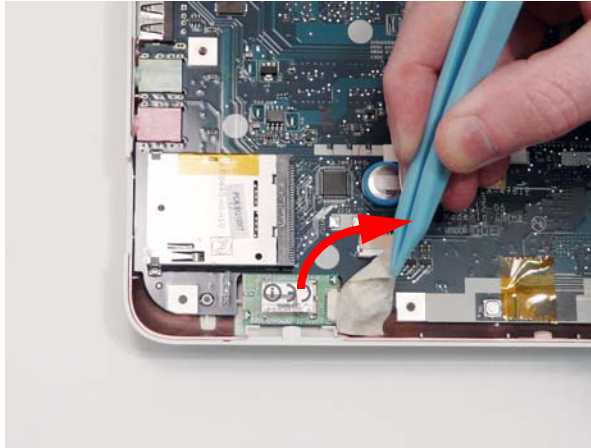

2. Disconnect the Bluetooth cable from the Mainboard.

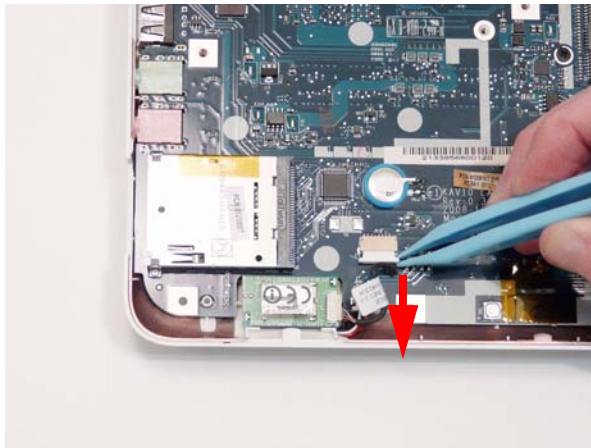

3. Lift the Bluetooth Module clear of the casing.

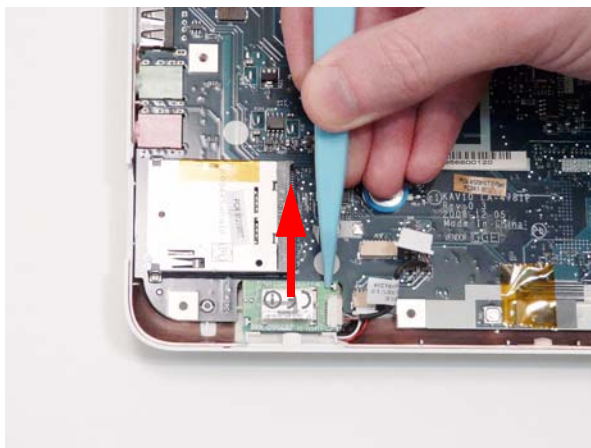

-
4. Turn the Bluetooth Module over and disconnect the Bluetooth cable.

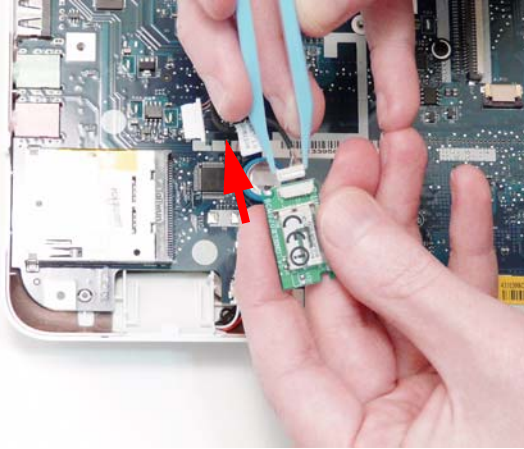

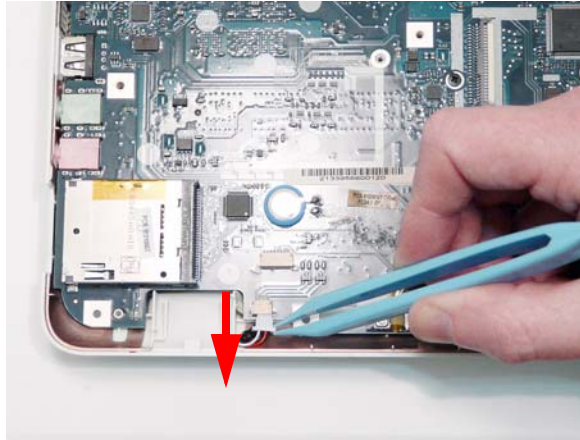

Removing the Mainboard and Power Cable

1. See "Removing the LCD Module" on page 63.
2. See "Removing the USB Board and Cable" on page 67.
3. See "Removing the Bluetooth Module" on page 69.
4. Disconnect the Speaker cable from the Mainboard.

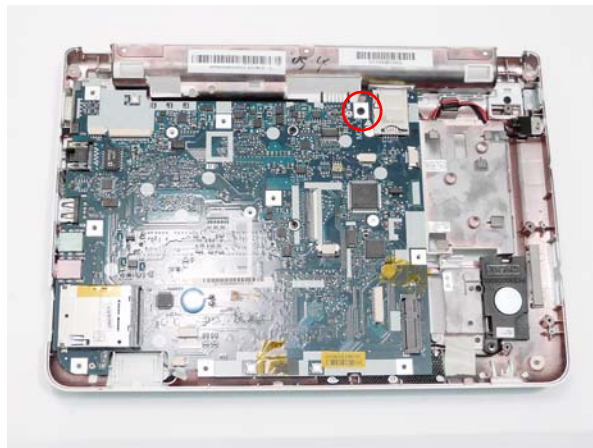

5. Remove the single securing screw from the Mainboard.



Step	Size	Quantity	Screw Type
Mainboard	M2*3	1	

6. Remove the power jack from the Lower Cover.

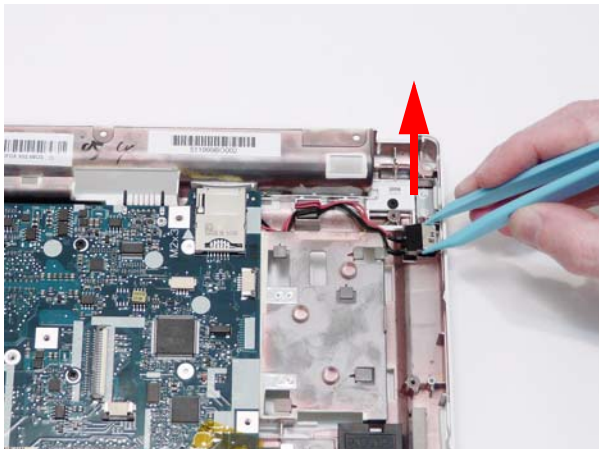

7. Remove the cable cluster from the Lower Cover.

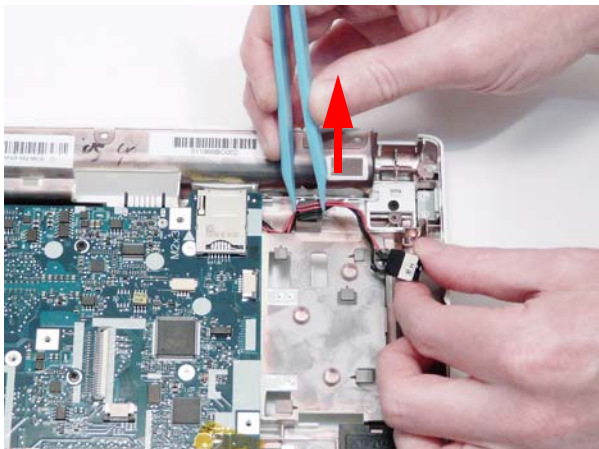

8. Lift the Mainboard, right side first, and remove it from the Lower Cover.

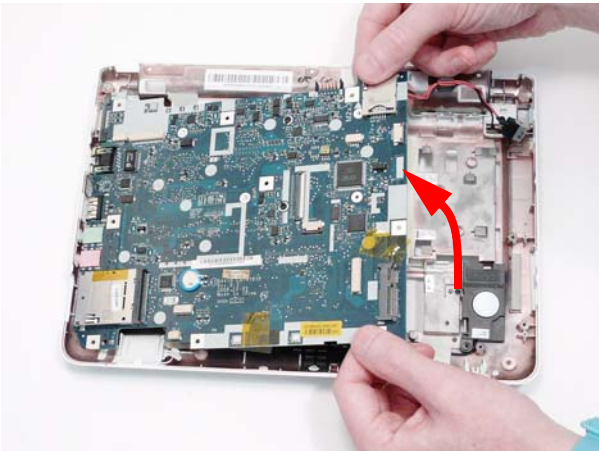

9. Turn the Mainboard over and disconnect the Power Cable.

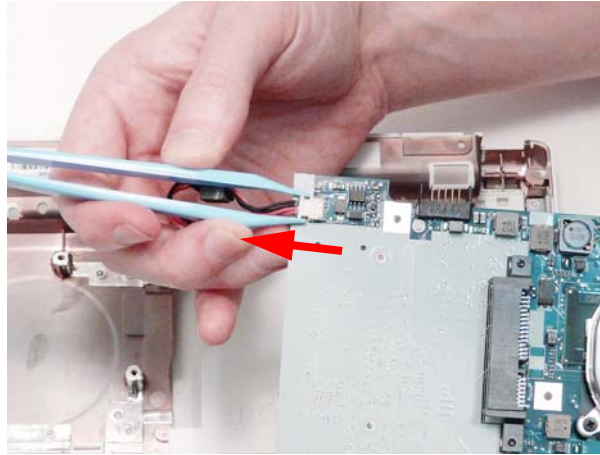

Removing the Speaker Module

1. See "Removing the Mainboard and Power Cable" on page 71.
2. Remove the adhesive strips holding the cables in place.

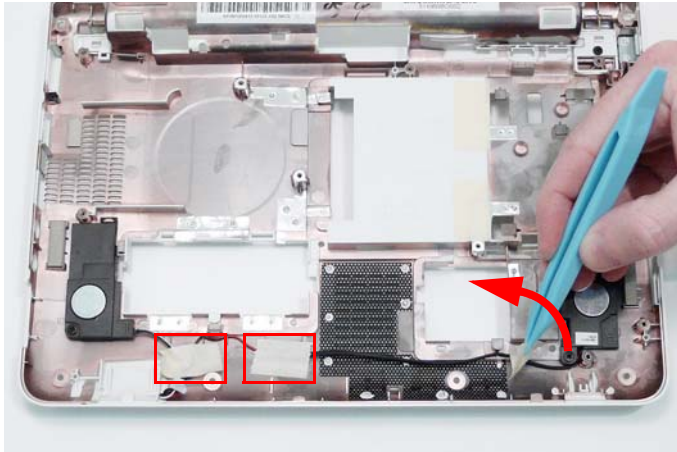

3. Remove the two securing screws (one for each Speaker).



Step	Size	Quantity	Screw Type
Speaker Module	M2*3	2	

4. Lift the Speakers individually from the upper cover as shown.

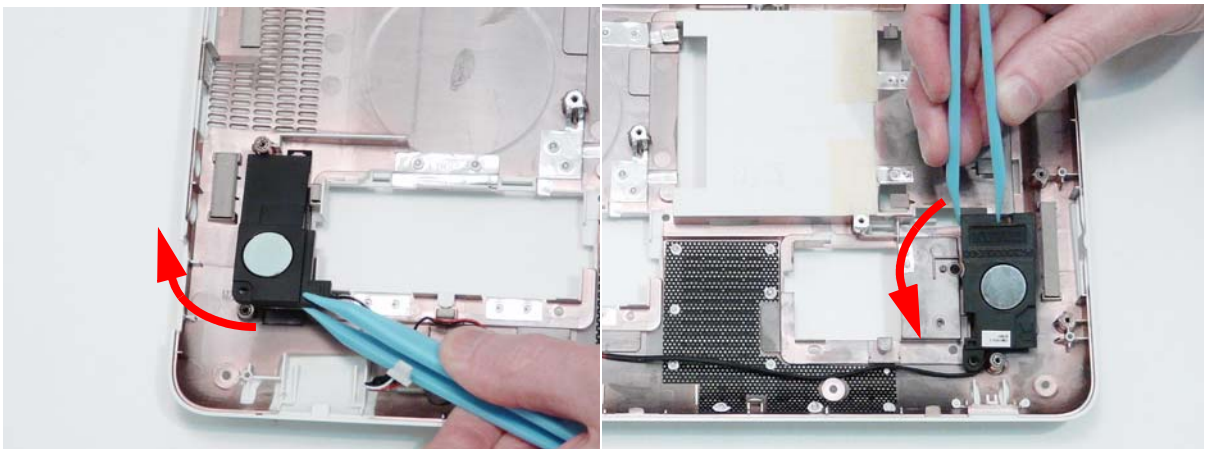

5. Remove the Speaker Module from the Lower Cover.

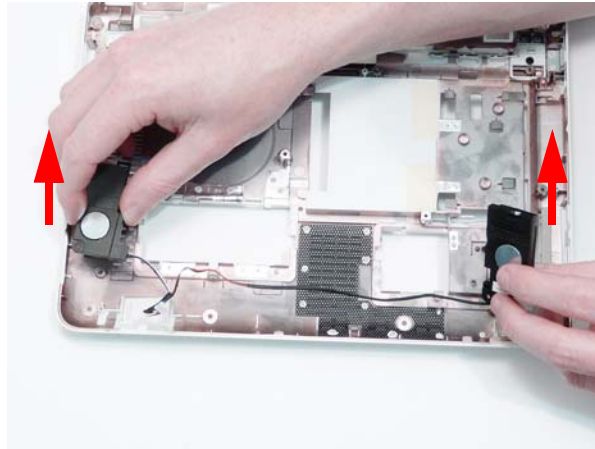



Removing the Thermal Module

1. See "Removing the Mainboard and Power Cable" on page 71.
2. Turn the Mainboard CPU side up, and place it on a clean surface.
3. Disconnect the Fan cable from the Mainboard.

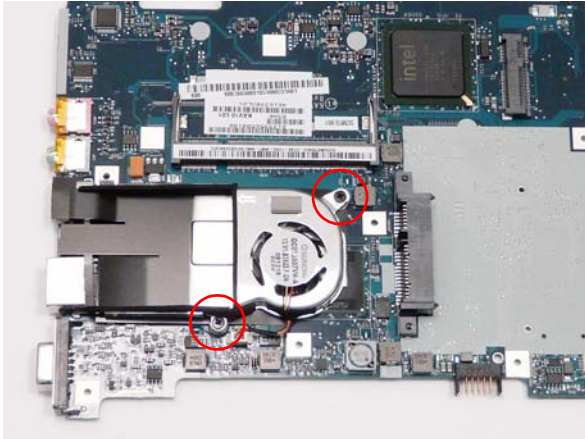

4. Remove the two securing screws from the Thermal Module.



Step	Size	Quantity	Screw Type
Thermal Module	M2*3	2	

-
5. Grasp the Thermal Module and gently twist side to side to break the seal between the Thermal Module and heat pad.

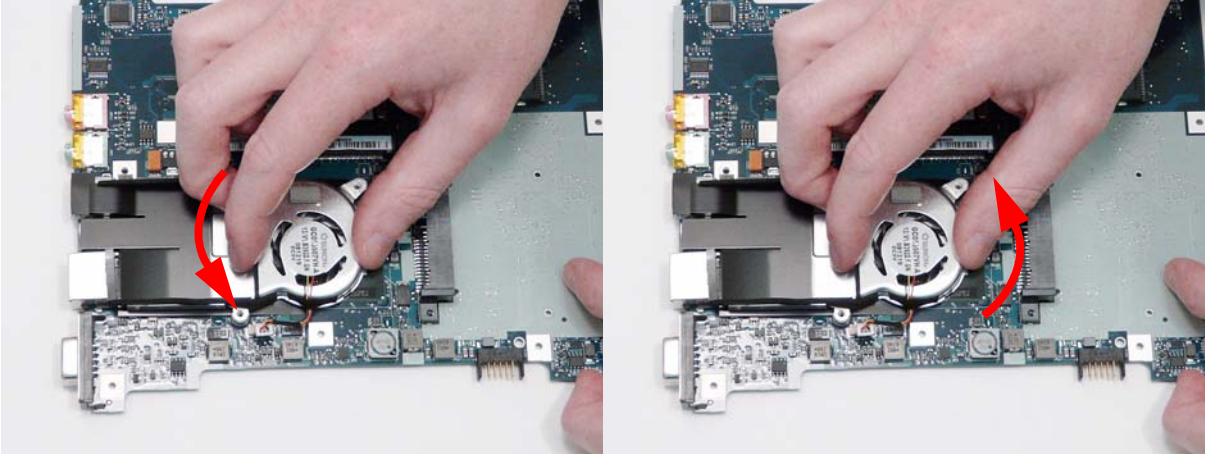

6. Lift the Thermal Module clear of the Mainboard.

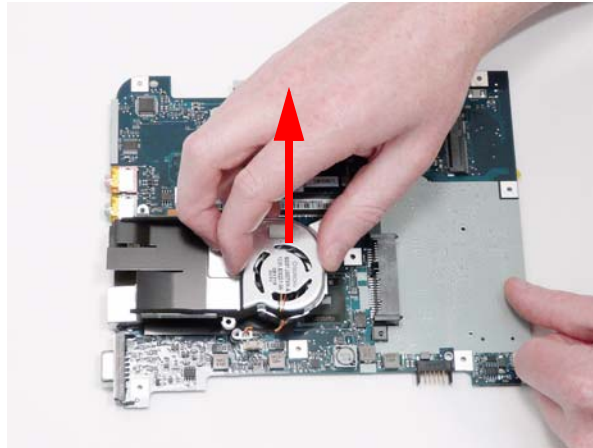

LCD Module Disassembly Process

IMPORTANT: Cable paths and positioning may not represent the actual model. During the removal and replacement of components, ensure all available cable channels and clips are used and that the cables are replaced in the same position.

LCD Module Disassembly Flowchart

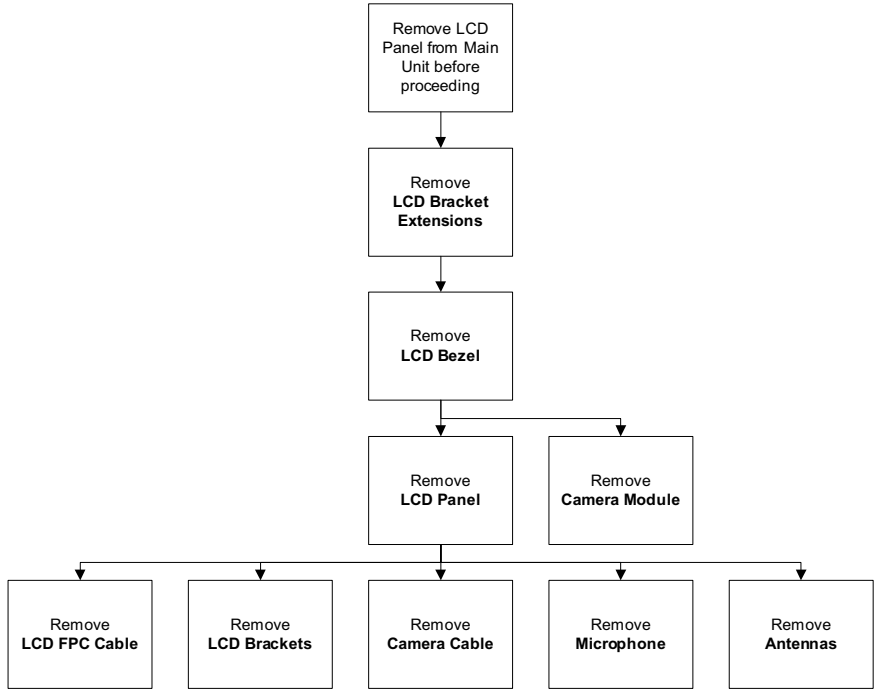

Screw List

Step	Screw	Quantity	Part No.
LCD Bezel	M2*6	4	86.S5502.002
LCD Panel	M2*6	2	86.S5502.002
LCD Brackets	M2*3	4	86.S5502.001

Removing the LCD Bracket Extensions

1. See "Removing the LCD Module" on page 63.
2. Remove the right side LCD Bracket Extension from the LCD Bracket as shown.

IMPORTANT:The Extensions may not represent the actual model. During the removal and replacement of components, ensure all available cable channels and clips are used and that the cables are replaced in the same position.

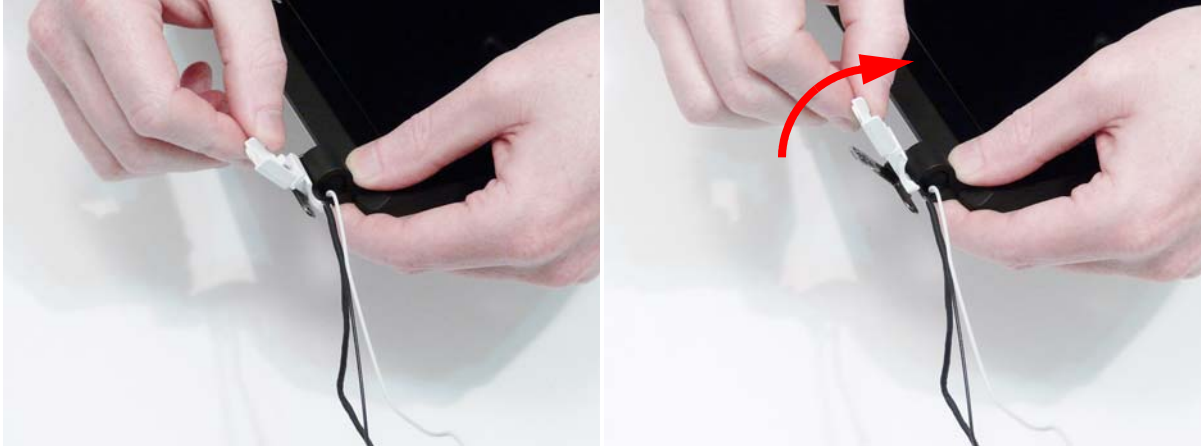

3. Remove the left side LCD Bracket Extension from the LCD Bracket as shown.



Removing the LCD Bezel

1. See "Removing the LCD Bracket Extensions" on page 79.
2. Remove the four screw caps and screws from the LCD Bezel.
NOTE: The two center screw caps at the top of the bezel are for protection only.



Step	Size	Quantity	Screw Type
LCD Bezel	M2*6	4	

3. Starting from the inside top edge, pry the bezel away from the panel. Continue moving down the sides until the bezel is removed. If necessary, use a plastic pry to release the corners of the bezel.

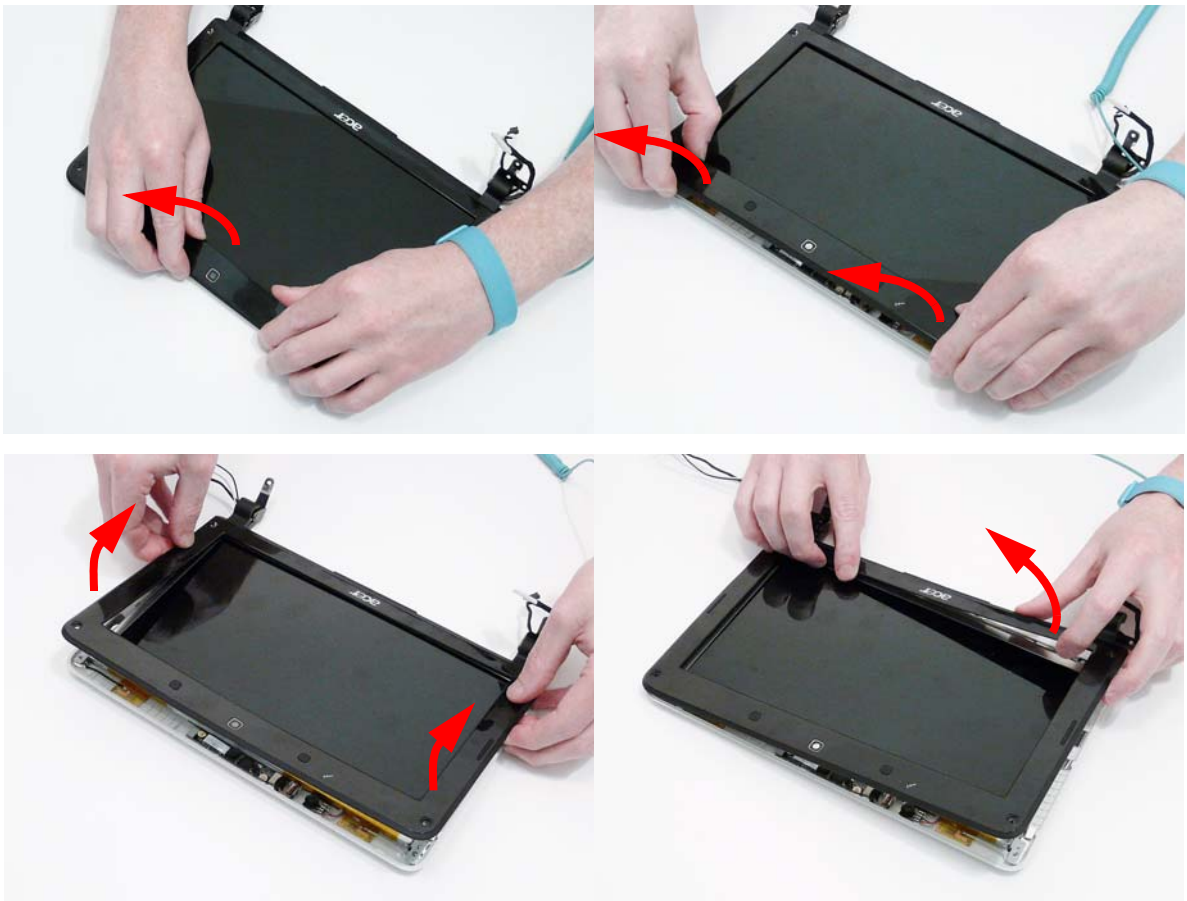

4. Lift up the bezel and remove it from the LCD Module.

IMPORTANT: If the LCD Bezel is replaced, remove the lid sensor magnet from the bezel, and attach it to the replacement bezel.



Removing the Camera Board

1. See "Removing the LCD Bezel" on page 80.
2. Disconnect the cable from the Camera Board as shown.

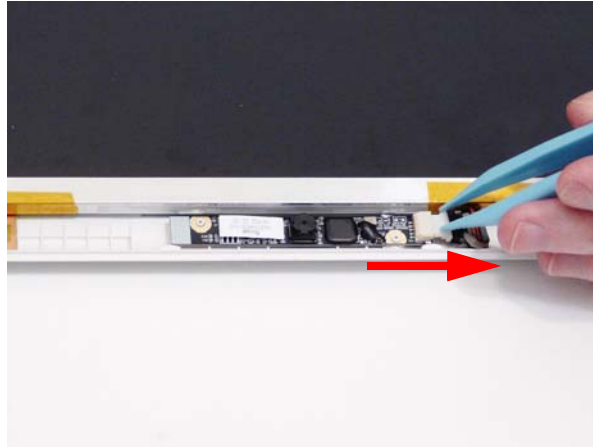

3. Remove the Camera Board from the LCD Module.

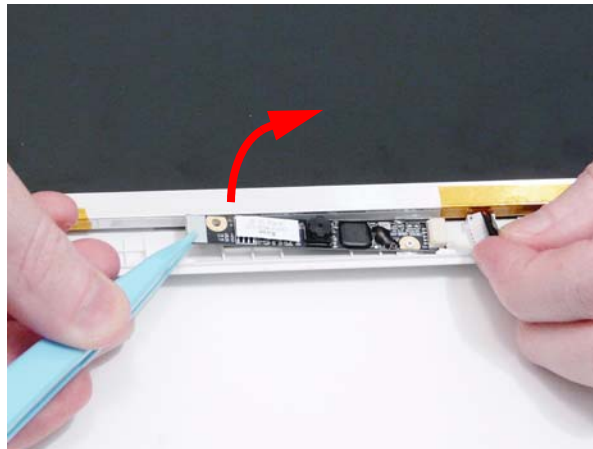

Removing the LCD Panel

1. See "Removing the Camera Board" on page 82.
2. Remove the two securing screws from the LCD Panel.



Step	Size	Quantity	Screw Type
LCD Panel	M2*6	2	

3. Hold the LCD Panel from the sides and lift to remove. Place it on a clean surface.



Removing the LCD Brackets and FPC Cable

- 1. See "Removing the LCD Panel" on page 83.
- 2. Remove the four securing screws (two each side) from the LCD Panel brackets.



Step	Size	Quantity	Screw Type
LCD Brackets	M2*3	4	

- 3. Turn the LCD panel over on a clean surface. Remove the adhesive strips securing the LCD cable.

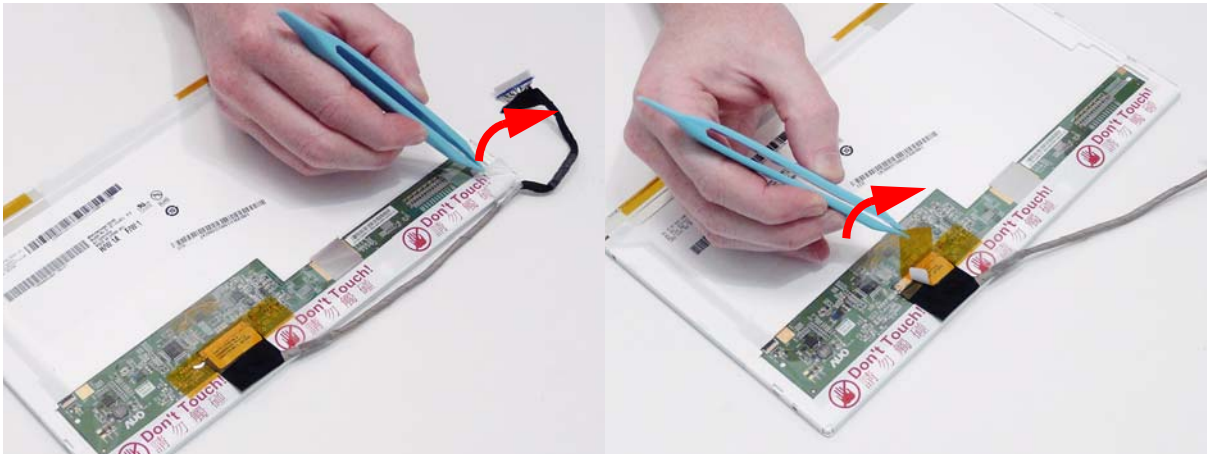

4. Carefully lift the adhesive tape securing the cable connector to the LCD Panel.



5. Hold the adhesive tape clear of the LCD Panel and disconnect the LCD cable as shown.

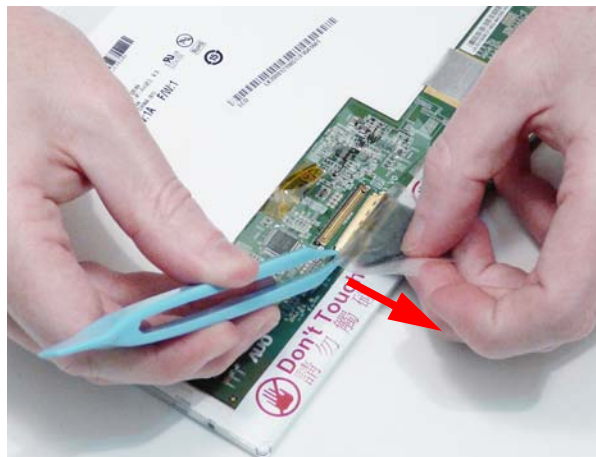

Removing the Microphone Board

1. See "Removing the LCD Panel" on page 83.
2. Remove the adhesive strips holding the MIC cable in place.

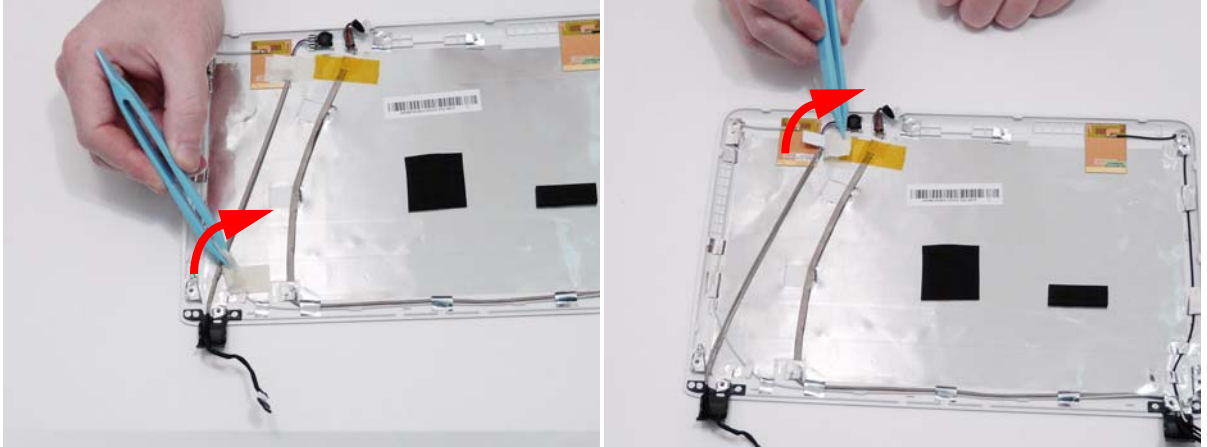

3. Remove the MIC Board from the LCD Module.

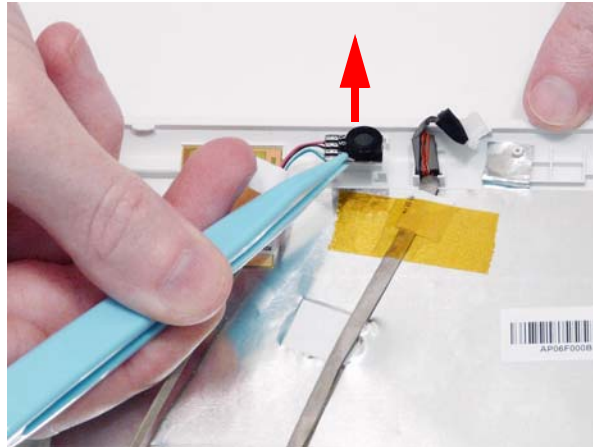

Removing the Camera Cable

1. See "Removing the LCD Panel" on page 83.
2. Remove the adhesive strips holding the Camera cable in place.

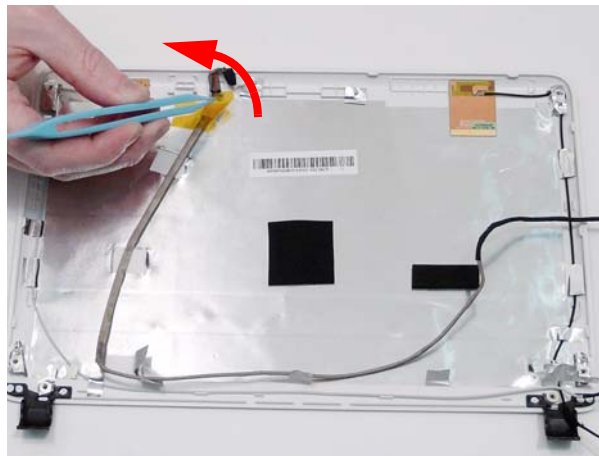
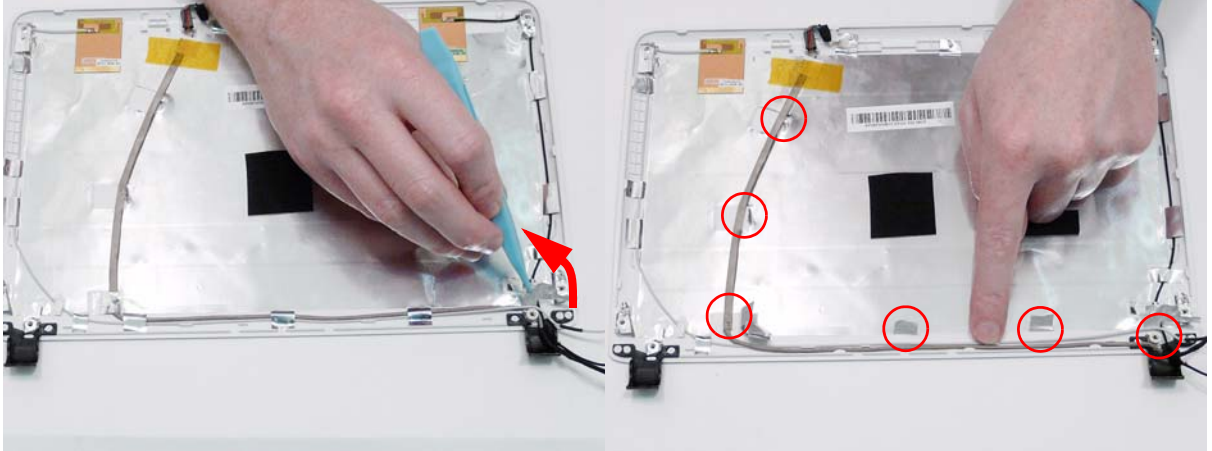

3. Remove the Camera cable from the LCD Module.



Removing the Antennas

1. See "Removing the LCD Panel" on page 83.
2. Remove the adhesive strips holding the Antenna cables in place.



3. Carefully pry up the Antenna pads, as shown, and remove the pads from the LCD Module.

IMPORTANT: A strong adhesive is used to secure the Antenna pads in place. Take care not to bend the pads during removal.



LCD Module Reassembly Procedure

Replacing the Antennas, Camera Cable, and MIC

1. Replace the left and right Antenna cables as shown.

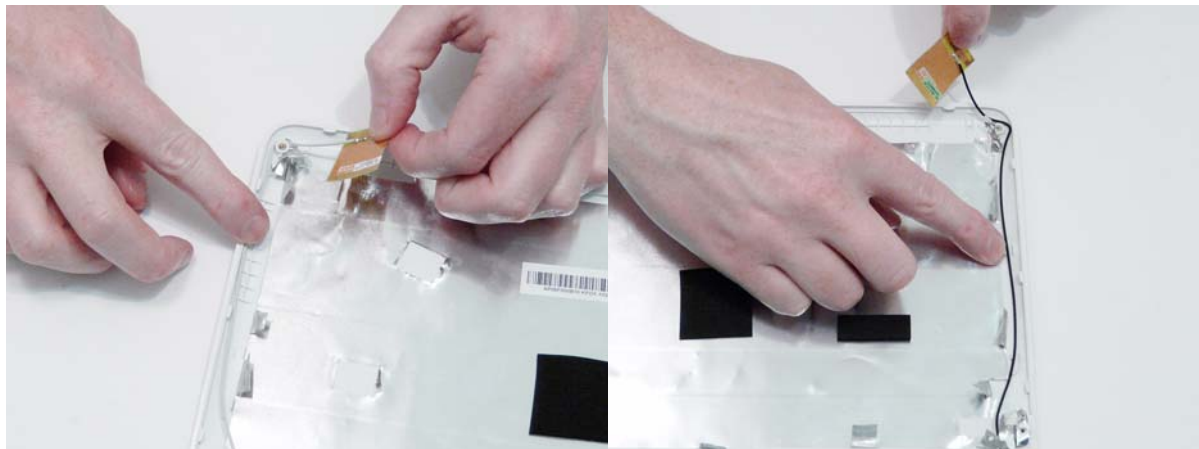

2. Ensure the cables run through all the available adhesive securing strips as shown. Press down the Antenna pads to secure them to the LCD Module (green callouts).



3. Replace the Camera cable in the LCD Module as shown.

4. Press the Camera cable down to secure it in place.

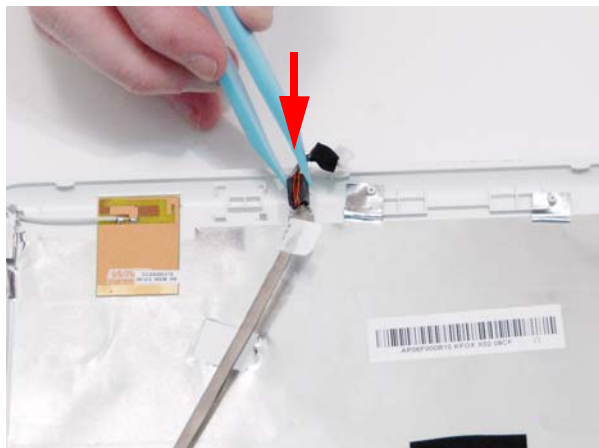

5. Run the cable as shown using all the available cable clips and replace the adhesive strip (green callout).

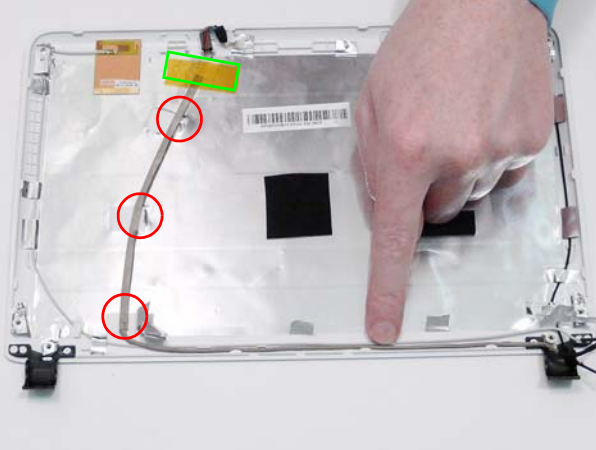

6. Replace the MIC Board in the LCD Module as shown.

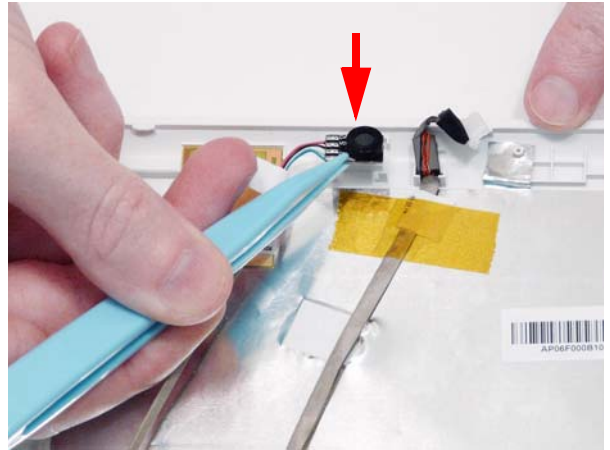

7. Press the MIC Board down to secure it in place.

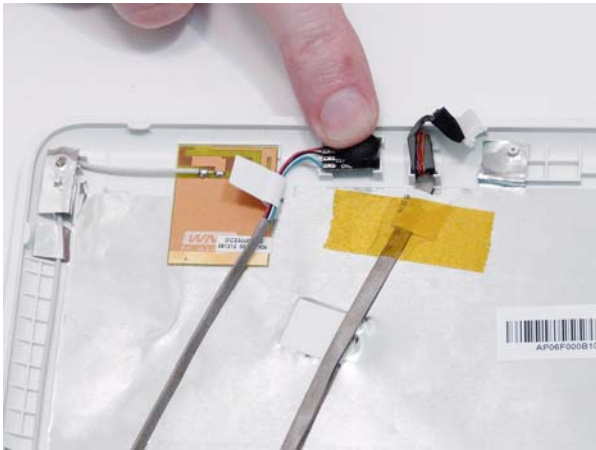

8. Run the MIC cable along the LCD Module as shown and replace the adhesive strips to secure it in place.

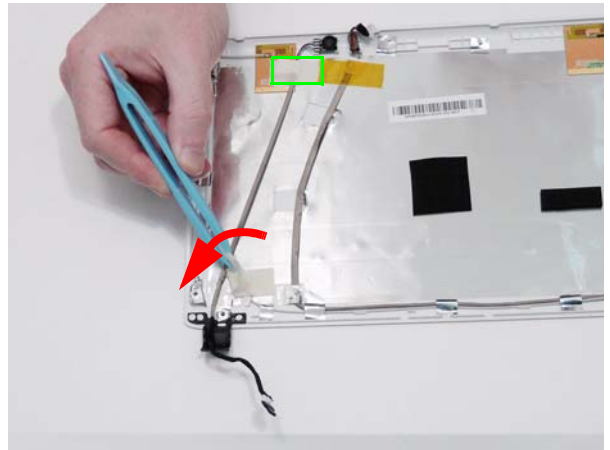

NOTE: The LCD Module appears as shown when the Antennas, Camera Cable, and MIC Board are replaced correctly.



Replacing the LCD Cable and Brackets

1. Insert the LCD Cable into the panel connector as shown.
2. Secure the connector by replacing the adhesive strip as shown.

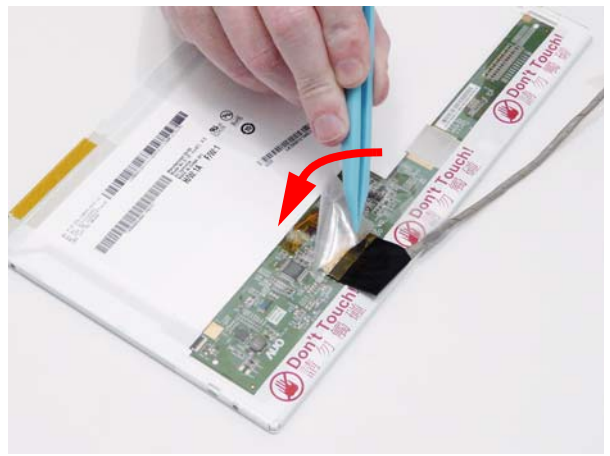
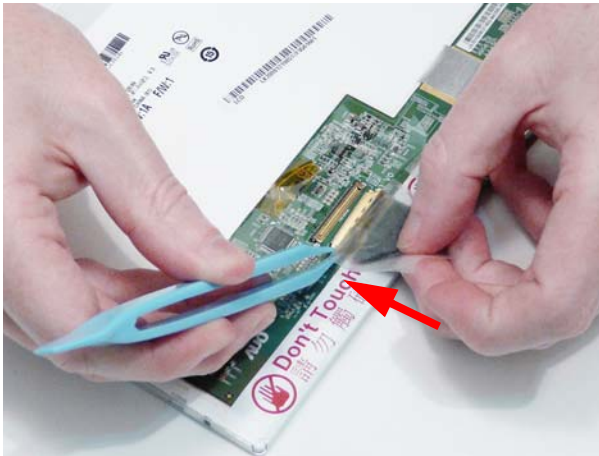

3. Run the LCD Cable as shown and replace the securing strips.

IMPORTANT: Ensure that the LCD Cable runs as shown to avoid trapping when the Bezel is replaced.



4. Align the screw holes and replace the left and right LCD brackets as shown.



5. Secure the brackets to the panel using four bracket screws (two each side).

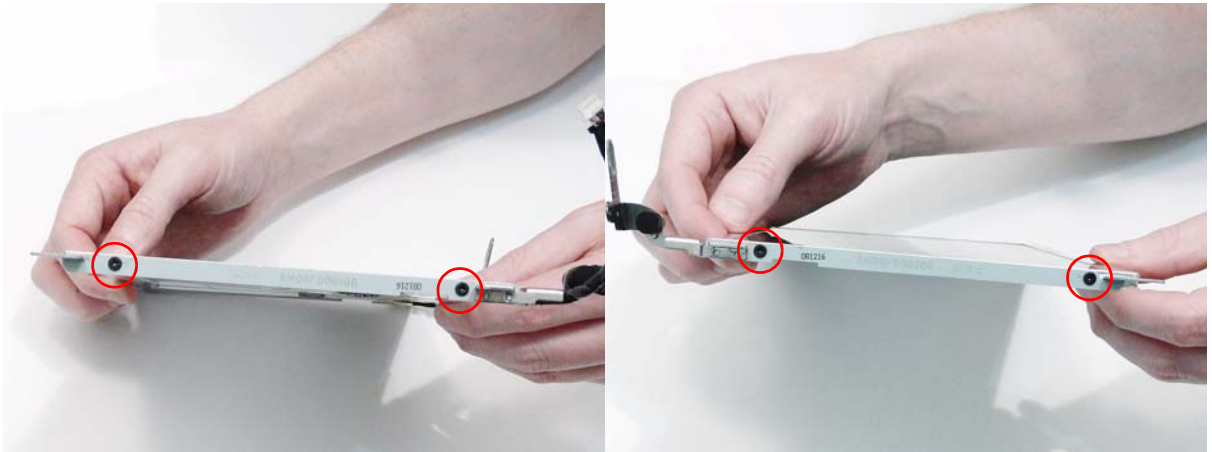

Replacing the LCD Panel

1. Replace the LCD Panel top edge first as shown.



2. Ensure the cables pass through the hinge wells as shown and rotate the panel downward in to the LCD Module.



3. Replace the two securing screws.



Replacing the Camera Module

1. Place the Camera Module in the LCD Module and press down to secure it in place.
2. Connect the Camera cable as shown.

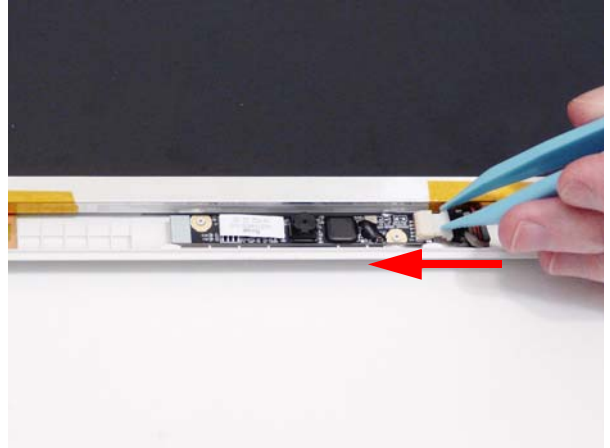
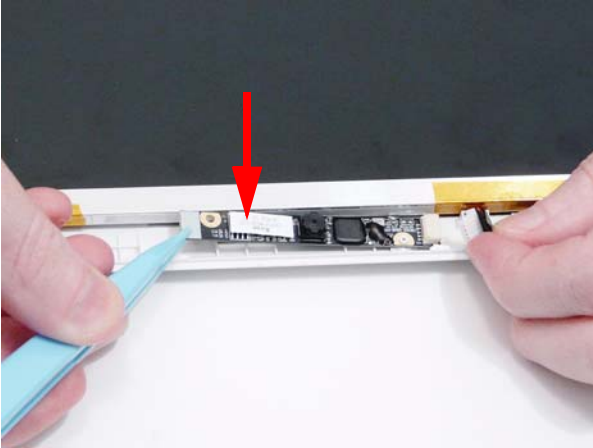

Replacing the LCD Bezel

IMPORTANT: If the LCD Bezel is replaced, remove the lid sensor magnet from the bezel, and attach it to the replacement bezel.



1. Replace the bezel bottom edge first as shown.

2. Starting at the hinge wells, press down to secure the bezel in place.



3. Press down around the edges of the bezel to secure it in place.



4. Replace the four screws and screw caps.



Replacing the LCD Bracket Extensions

IMPORTANT: The Extensions may not represent the actual model. During the removal and replacement of components, ensure all available cable channels and clips are used and that the cables are replaced in the same position.

1. Ensure the left side Power and MIC cables run as shown.

NOTE: The MIC cable runs underneath the left side bracket extension.



2. Replace the left side LCD Bracket Extension and press down to secure it in place.



3. Replace the right side LCD Bracket Extension and press down to secure it in place.

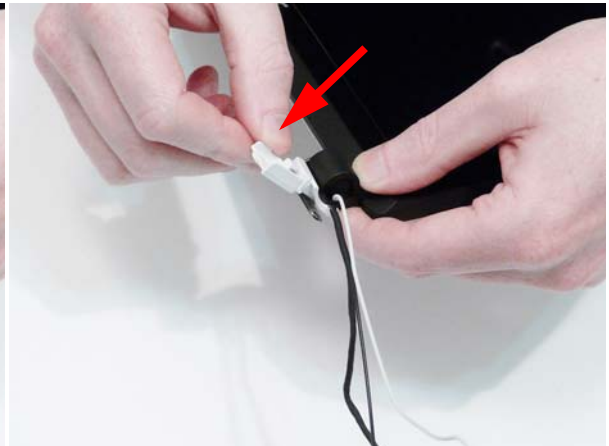
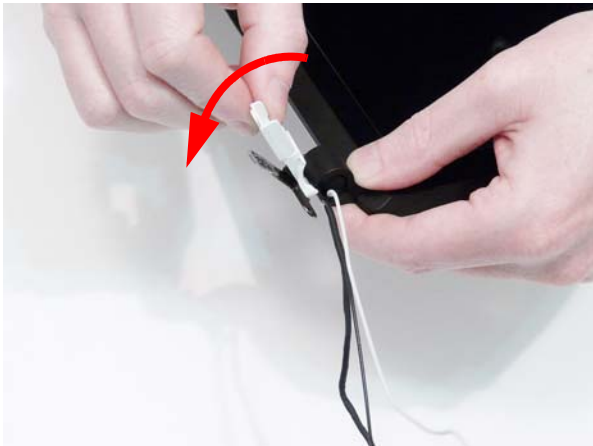

Main Module Reassembly Procedure

Replacing the Thermal Module

IMPORTANT: Ensure all heat pads are in place before replacing the Thermal Module.

The following thermal pads are approved for use:

- Eapus XR-PE

1. Align the screw holes on the Thermal Module and Mainboard and replace the module.
2. Replace the two securing screws in the Thermal Module.

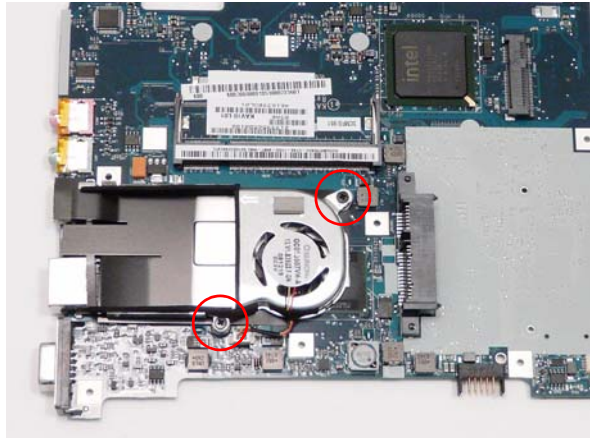
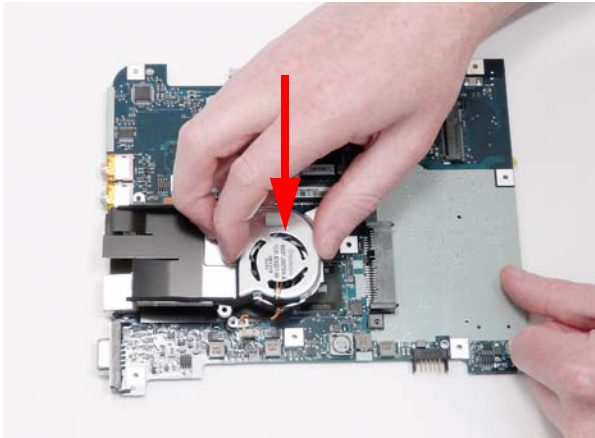

3. Connect the Fan cable to the Mainboard as shown.

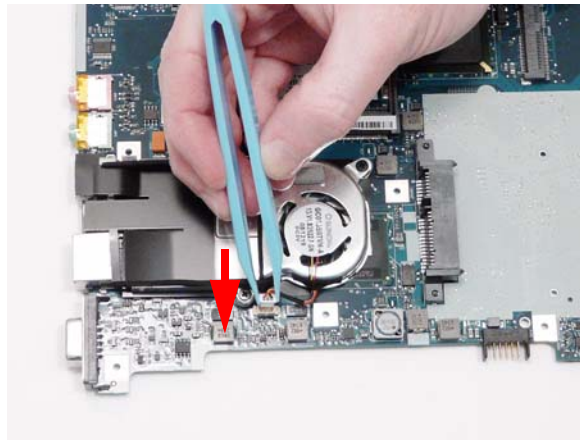

Replacing the Speaker Module

1. Replace the left and right Speakers in the Lower Cover as shown.

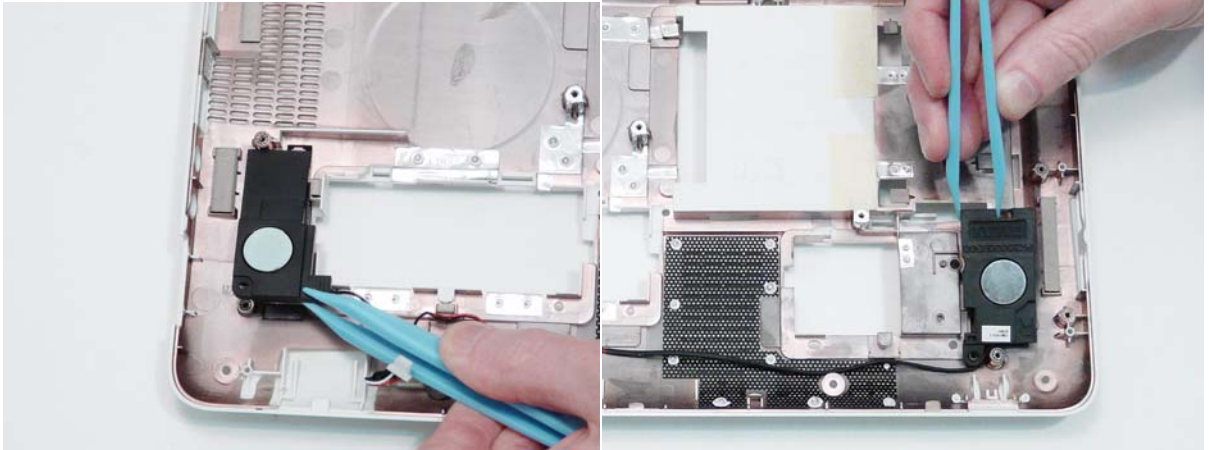

2. Replace the two securing screws (one in each Speaker).

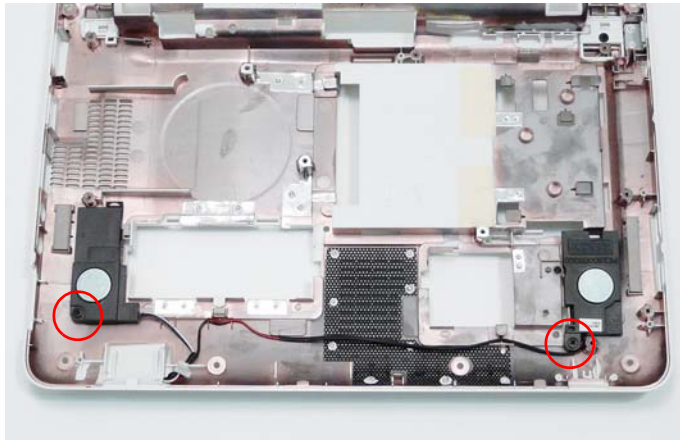

3. Run the Speaker Module cable along the Lower Cover as shown

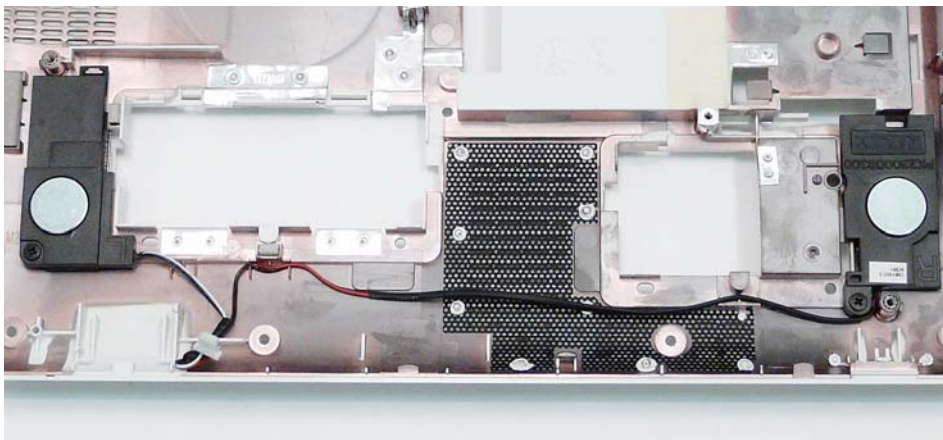

4. Secure the Speaker Module cable in place with the adhesive strips.

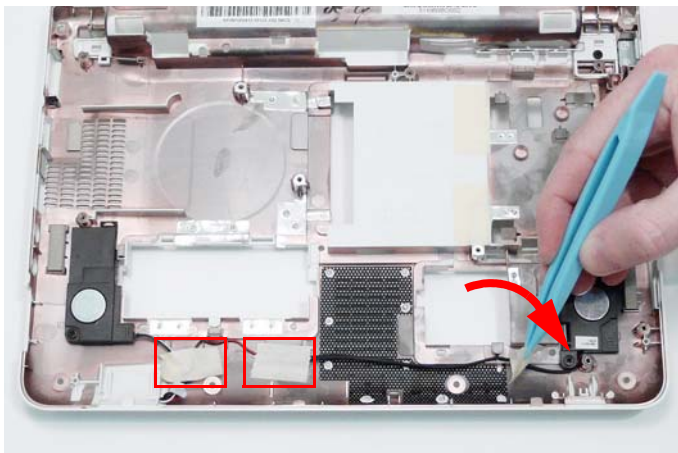

Replacing the Mainboard

1. Connect the Power Cable to the Mainboard.

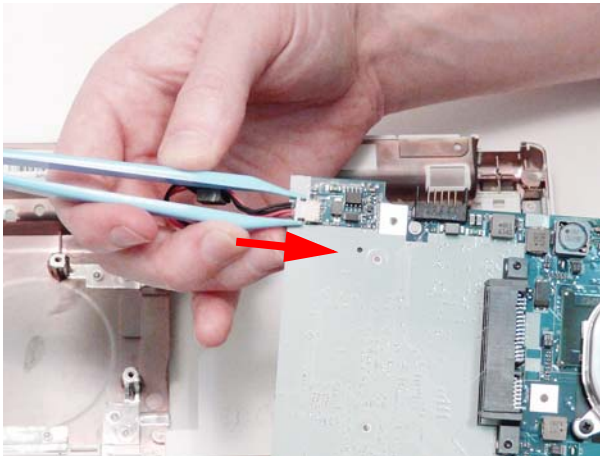

2. Insert the Mainboard left side first to ensure the I/O ports pass through the Lower Cover.

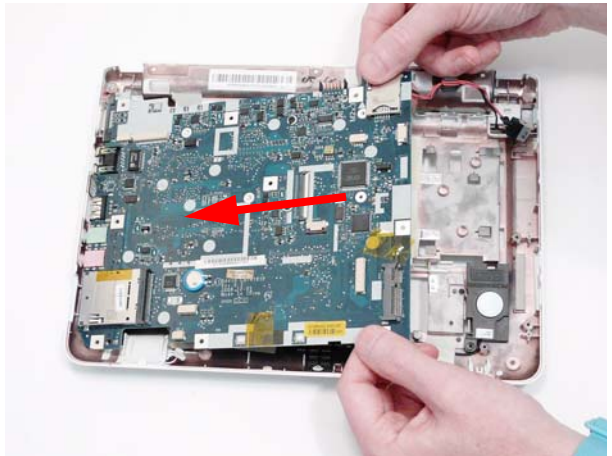

3. Lower the Mainboard into place as shown.
NOTE: Ensure the Speaker cable (green callout) is accessible before placing the Mainboard.

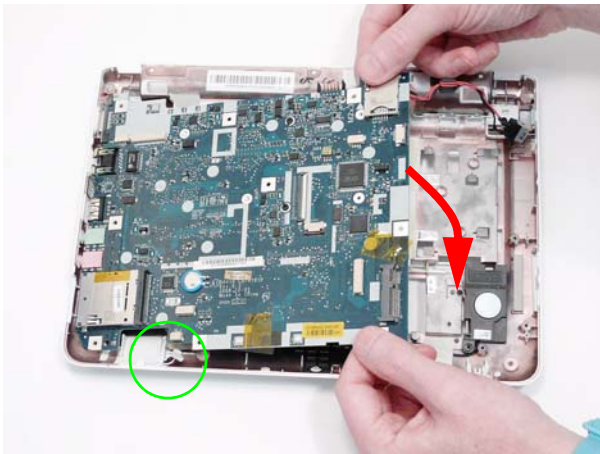

4. Place the cable cluster in to the Mainboard and press down secure it in place.

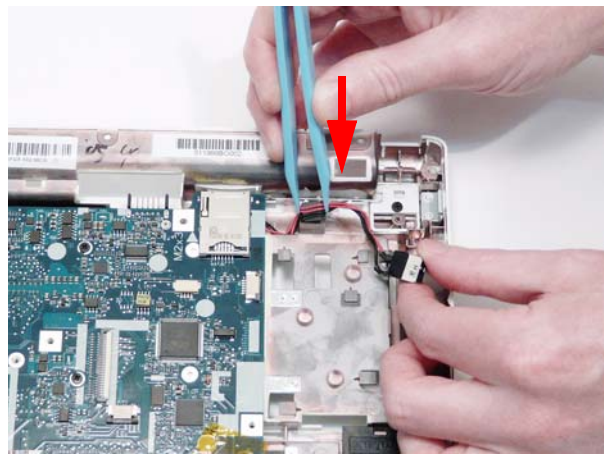

5. Place the power jack in to the Mainboard and press down secure it in place.

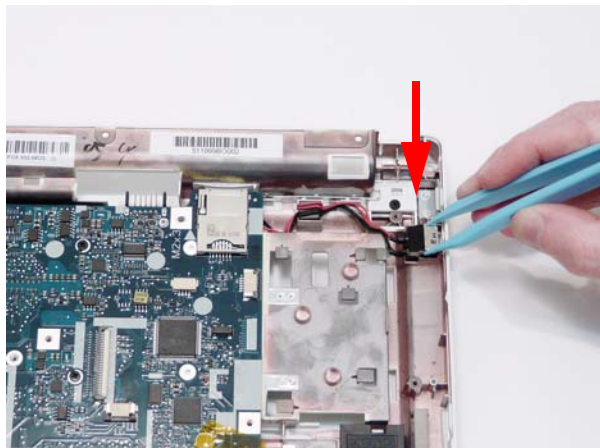

6. Replace the single securing screw.

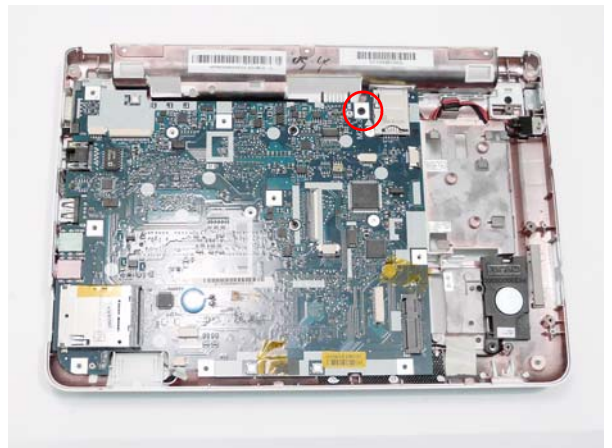

7. Connect the Speaker cable to the Mainboard.

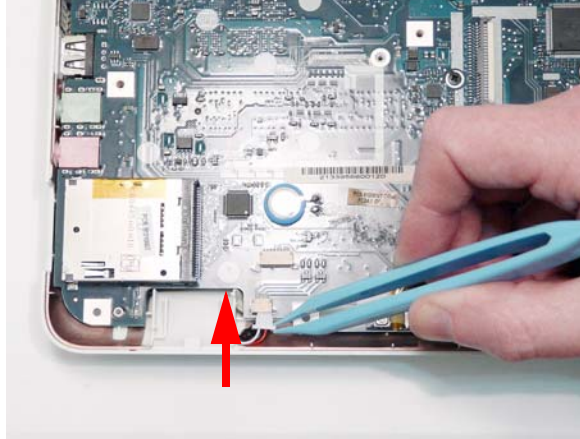

Replacing the Bluetooth Module

1. Connect the Bluetooth cable to the Bluetooth Module.

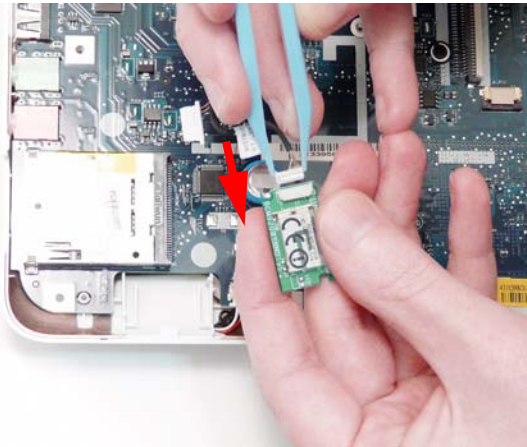

2. Place the Bluetooth Module in the Lower Cover as shown.

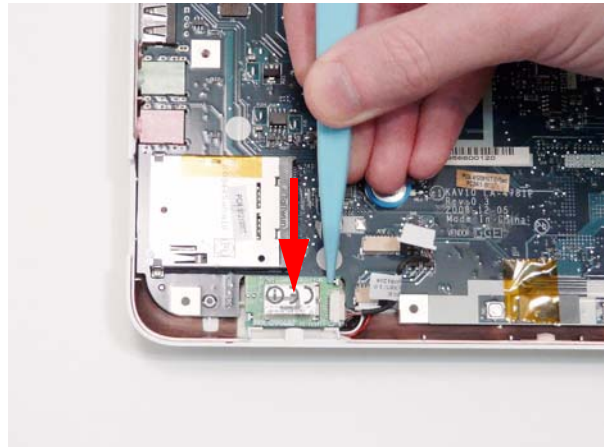

3. Connect the Bluetooth cable to the Mainboard.

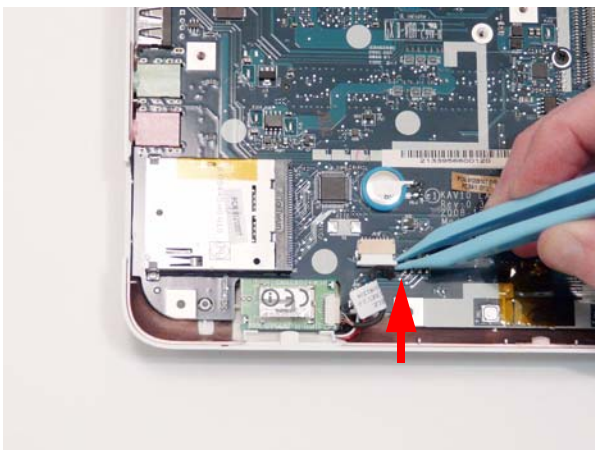

4. Secure the Bluetooth cable in place with the adhesive strip.

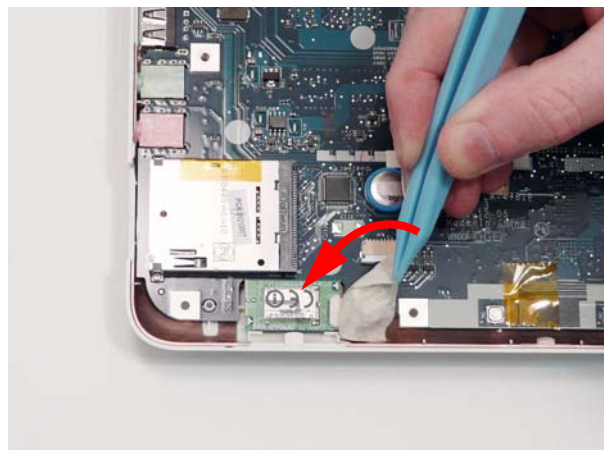

Replacing the USB Board

1. Place the USB Board in the Lower Cover as shown. Ensure that the WLAN switch (red callout) is correctly placed in the spacer (green callout).

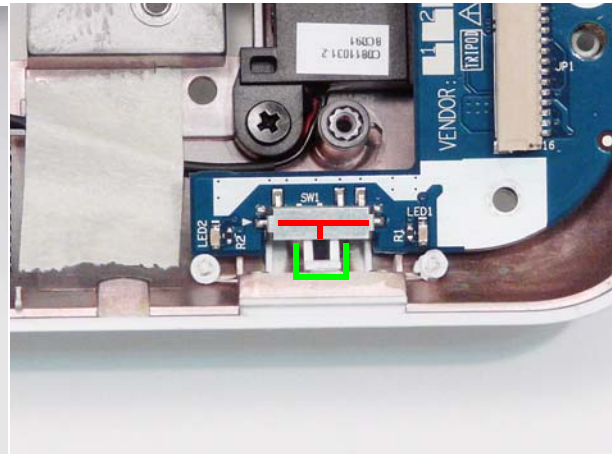
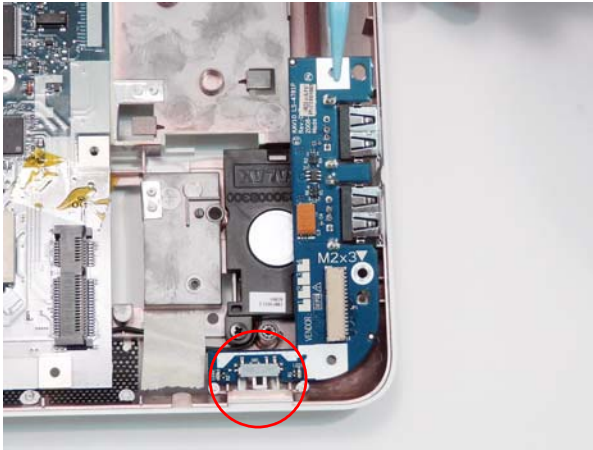

2. Replace the single securing screw.

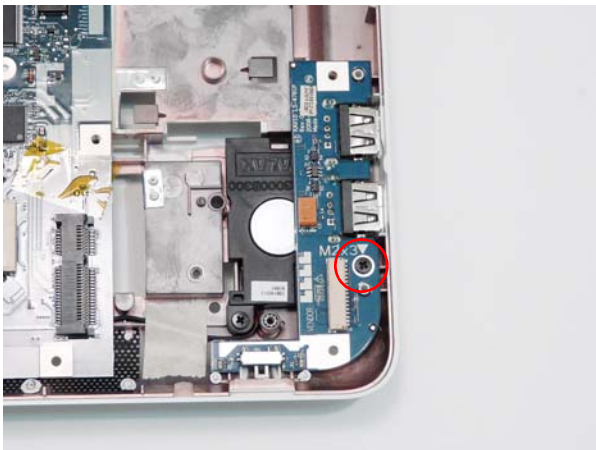

3. Connect the USB cable to the USB Board.

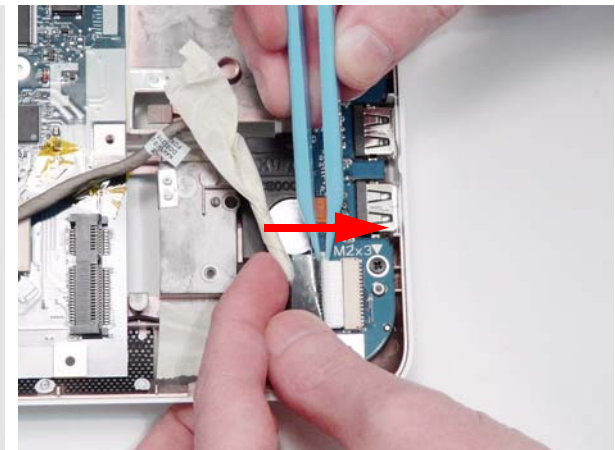

4. Secure the cable in the connector with the adhesive strip.

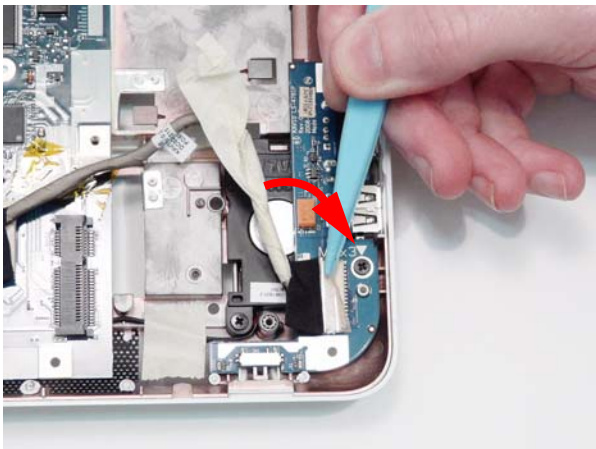

5. Connect the USB cable to the Mainboard.

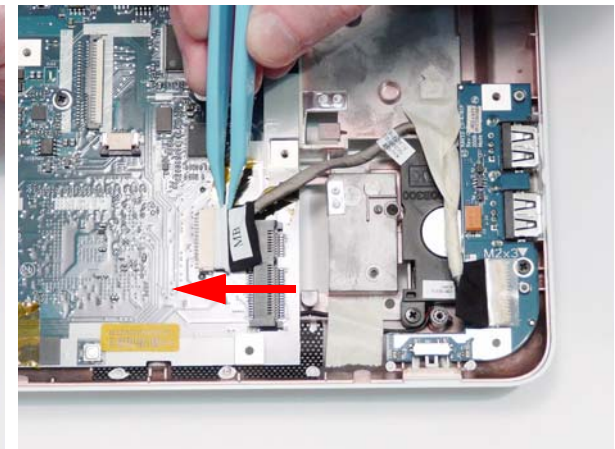

Replacing the LCD Module

1. Place the LCD Module on the Lower Cover and secure it in place with the two screws.

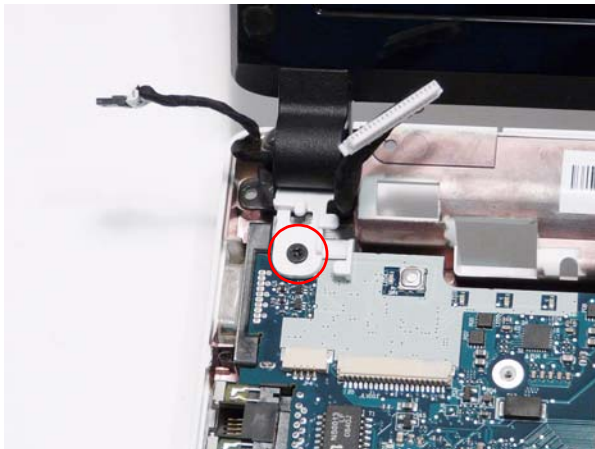
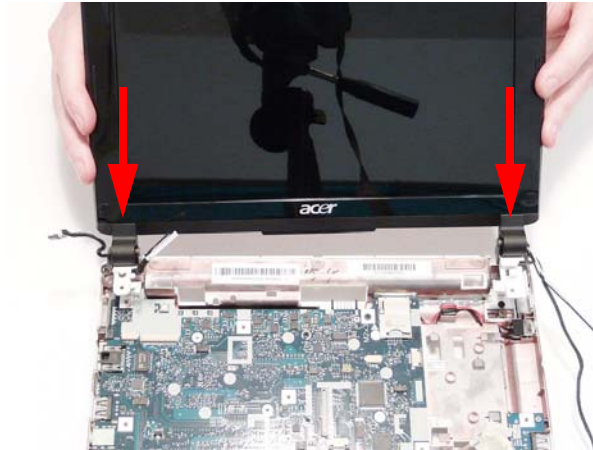

2. Run the MIC cable along the cable channel and reconnect it to the Mainboard.

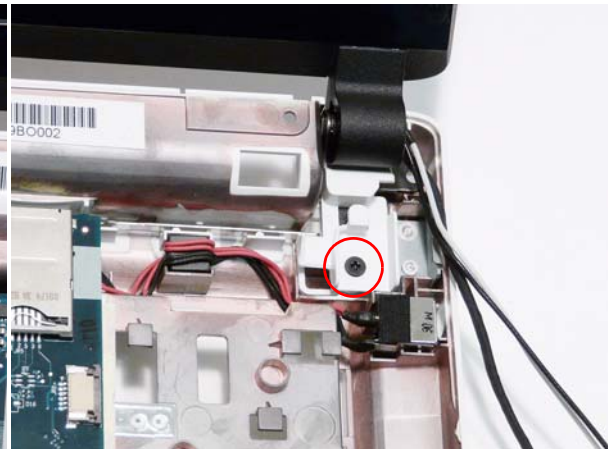
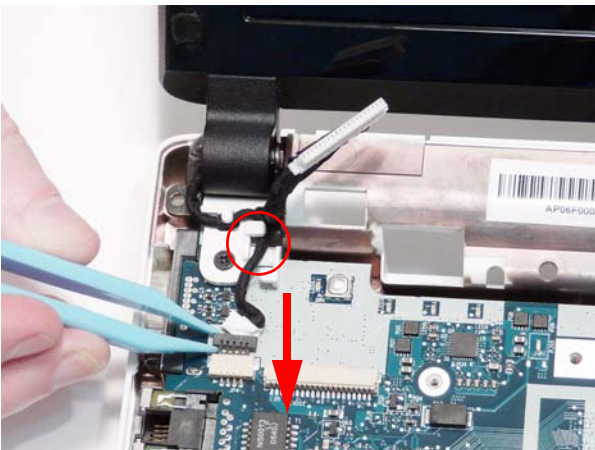

3. Run the Power cable along the cable channel and reconnect it to the Mainboard.

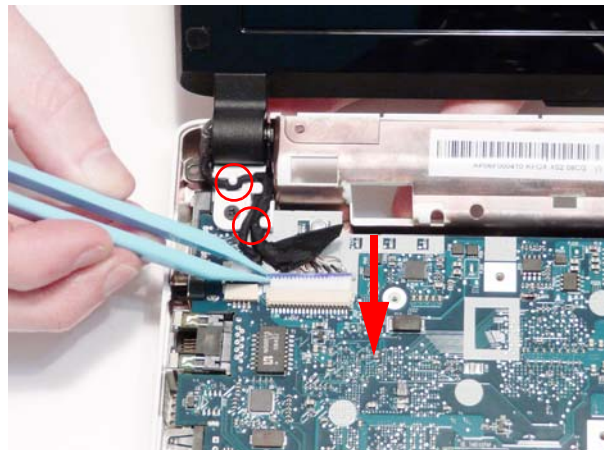

4. Run the Camera cable along the Lower Cover using all available cable clips.

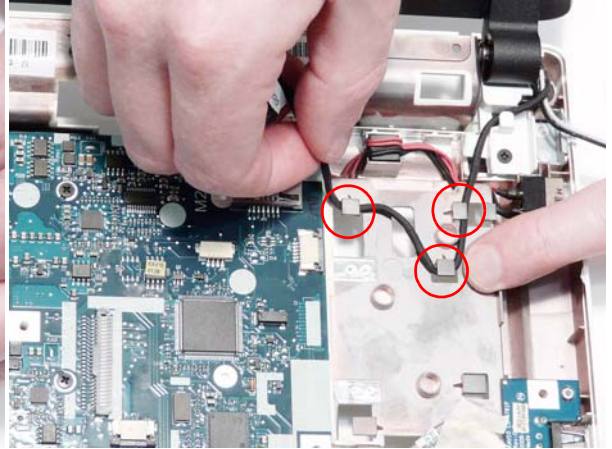
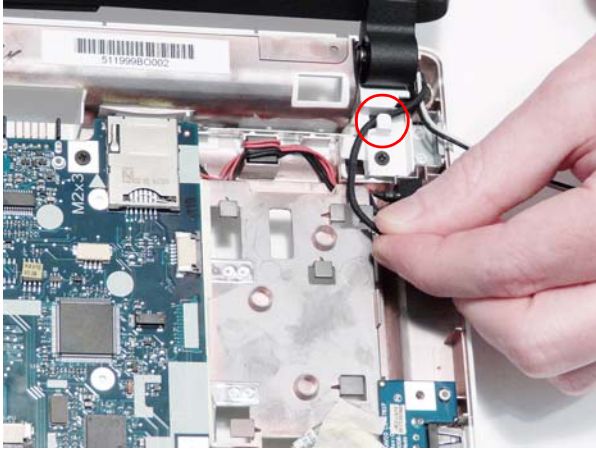

5. Connect the Camera cable to the Mainboard.

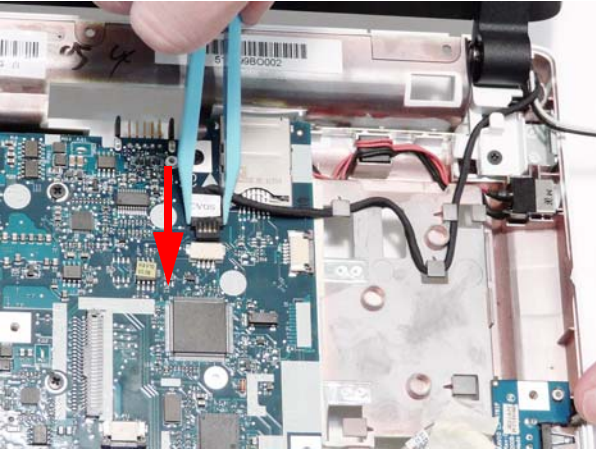

6. Run the Antenna cables along the Lower Cover using all available cable clips.

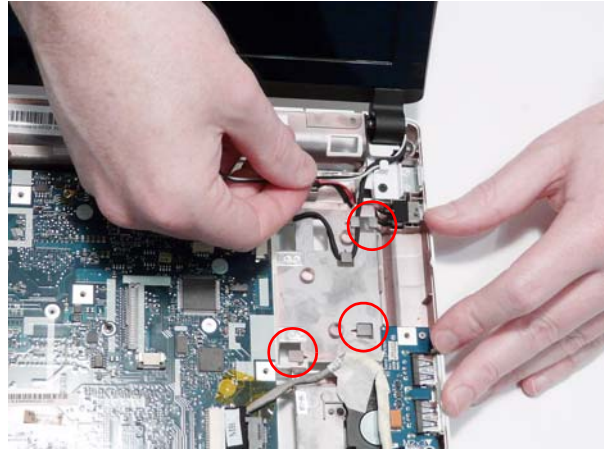

7. Pass the Antenna cables through the Lower Cover and them in place with an adhesive strip.

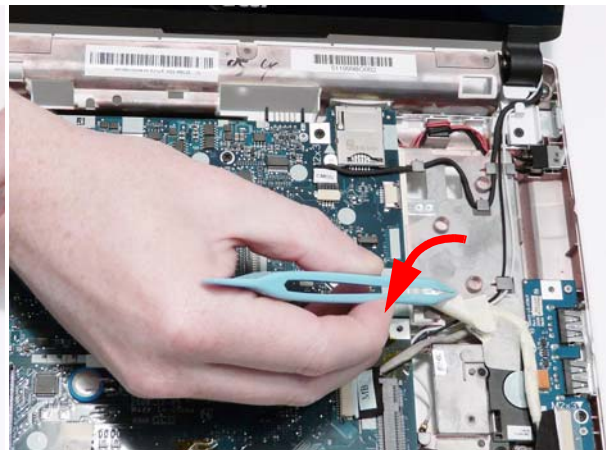
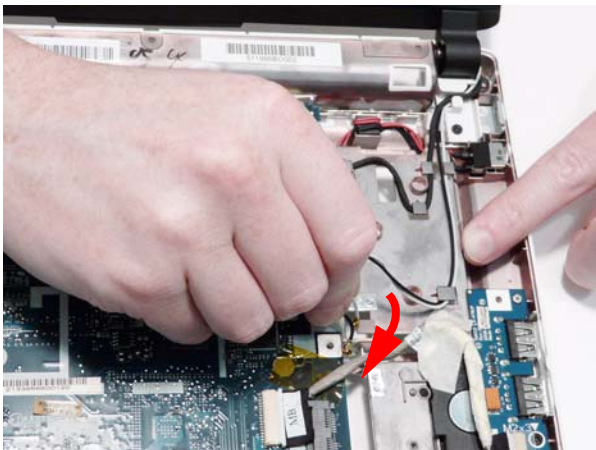

8. The Lower Cover appears as follows when all the LCD cables are correctly placed.

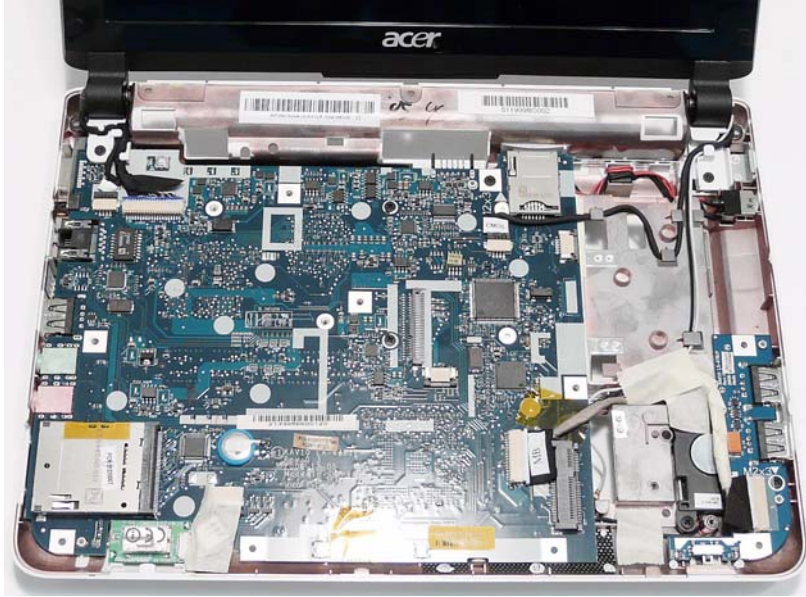

Replacing the TouchPad Bracket

1. Insert the FFC through the Upper Cover as shown, and connect it to the TouchPad Board.
2. Secure the FFC in place by closing the FFC latch.

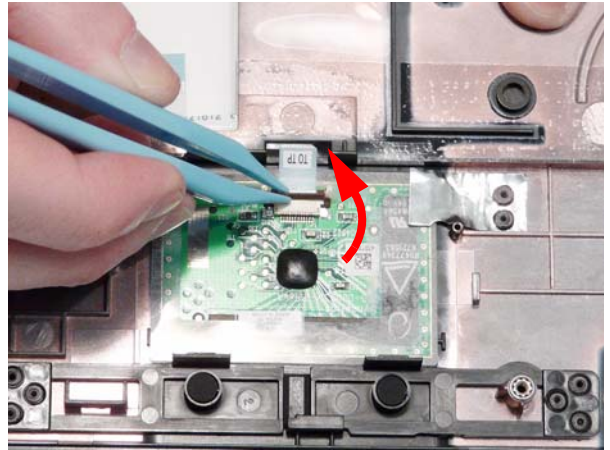
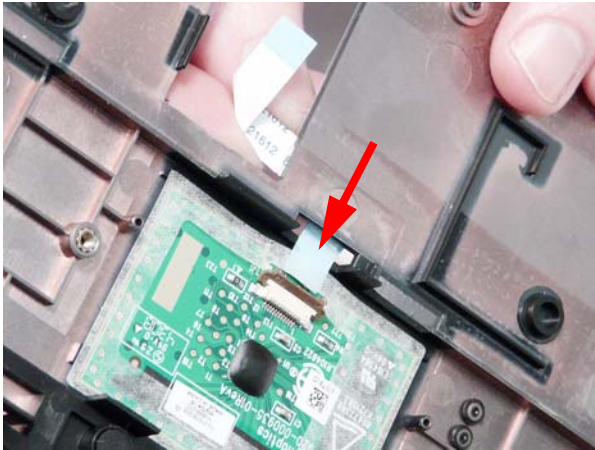

3. Insert the TouchPad Bracket bottom edge first as shown. Ensure that the three securing clips are engaged.
4. Rotate the bracket on to the Upper Cover, ensuring that the two locating pins are properly located.

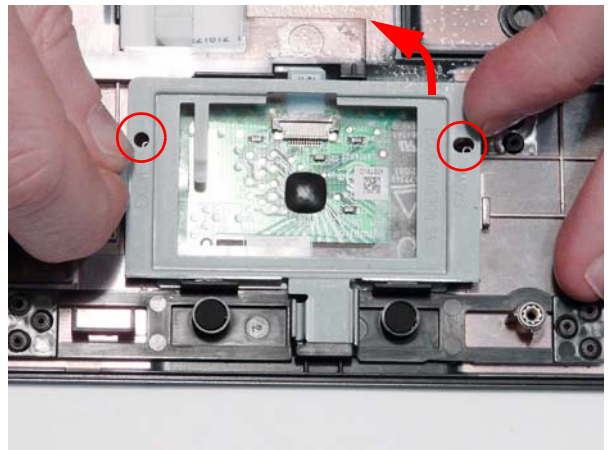
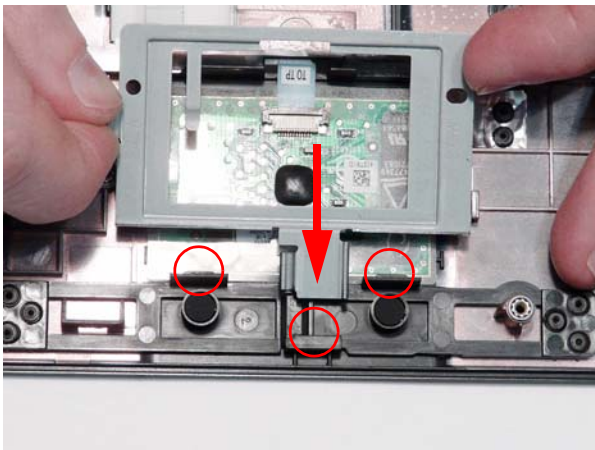

5. Slide the bracket in the direction of the arrow to engage the final securing pin.
6. Replace the single securing screw.

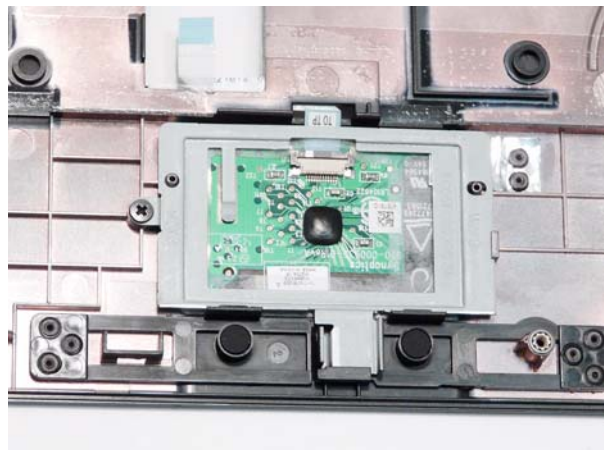
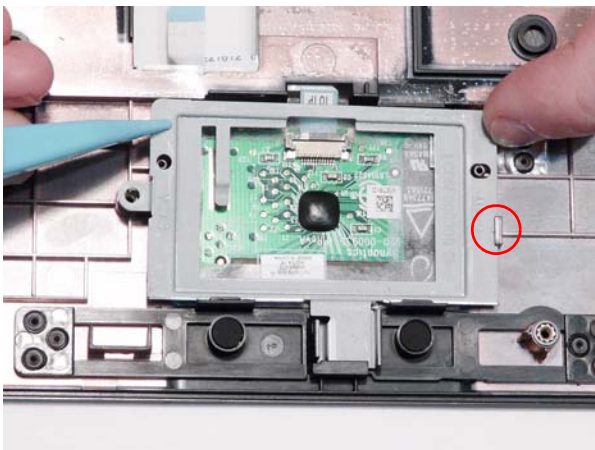

Replacing the Power Board

1.

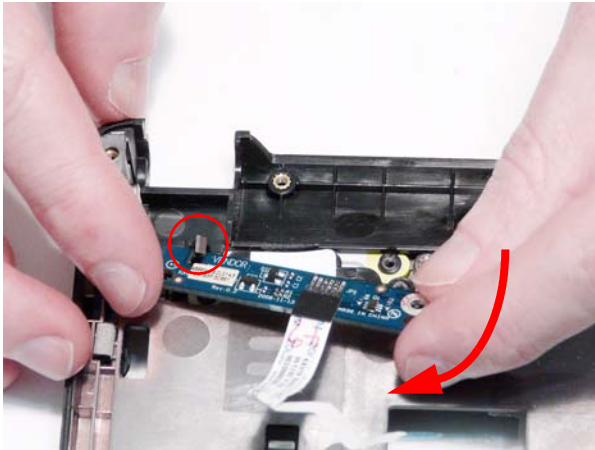

2.

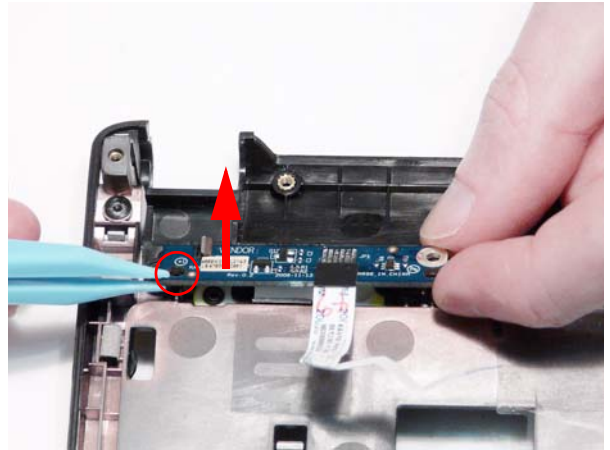

3. Press down the left and right sides of the Power Board to locate the securing pins.

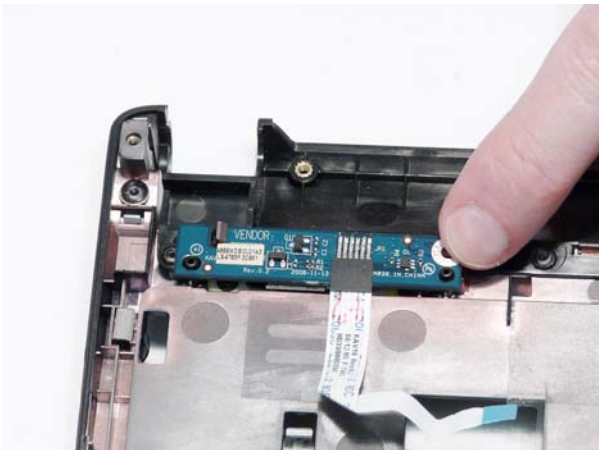
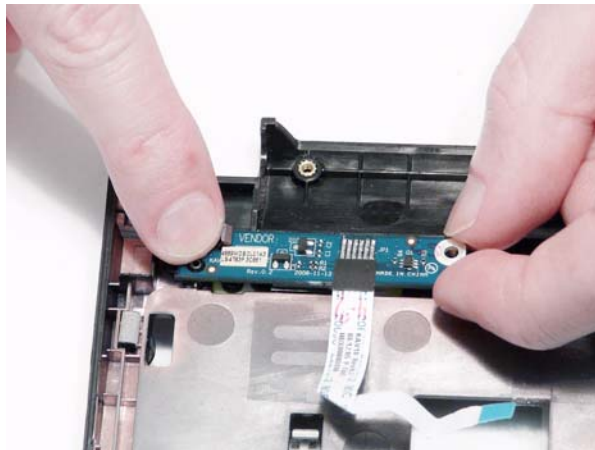

4. Replace the single securing screw and press down on the FFC (green callout) to secure it to the Upper Cover.

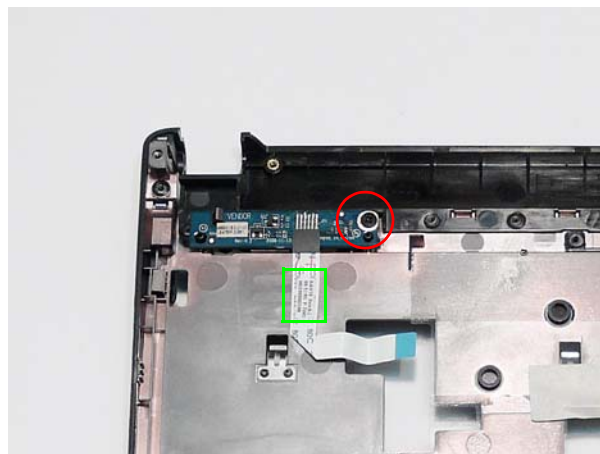

Replacing the Upper Cover

1. Place the Upper Cover on the Lower Cover left side first as shown.
2. Press down the Upper Cover at either side to snap it in to place.



3. Continue pressing down both sides of the Upper Cover and along the bottom edge to snap the covers together.



NOTE: Ensure there are no gaps between the Upper and Lower Covers.

4. Replace the five securing screws in the Upper Cover.

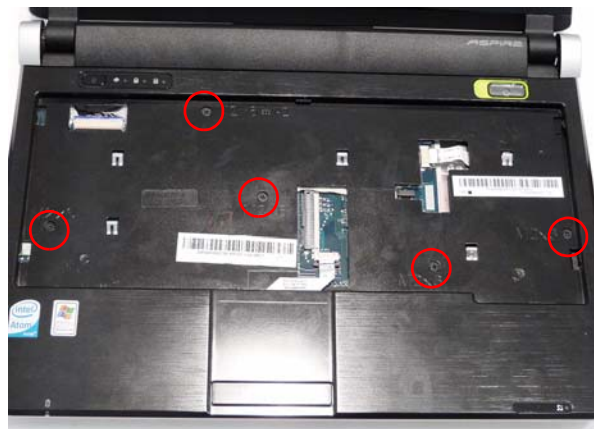

5. Reconnect the following cables to the Mainboard.

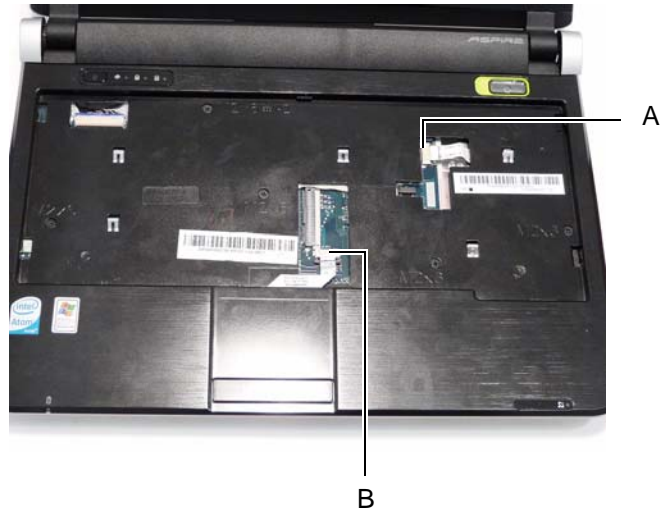

Connect A to the Mainboard.

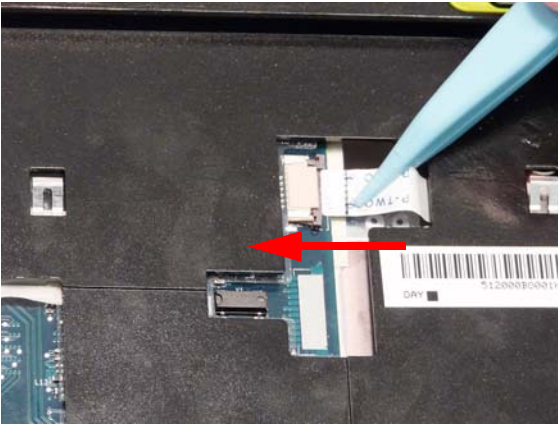

Secure the locking latch on A as shown.

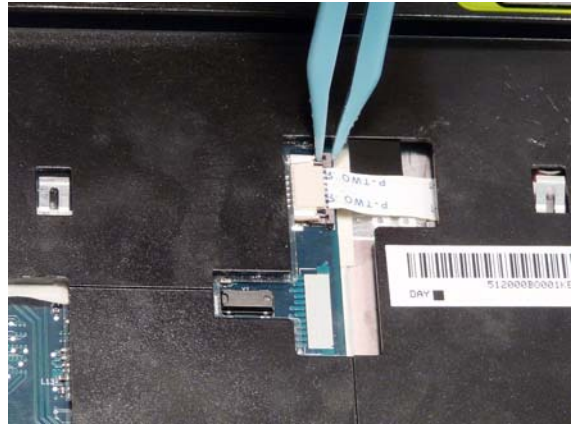

Connect B to the Mainboard.

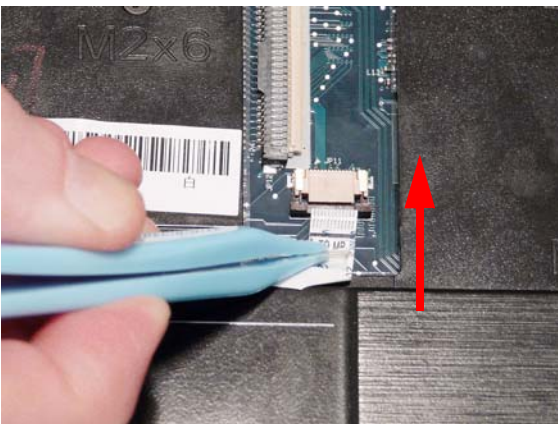

Secure the locking latch on B as shown.

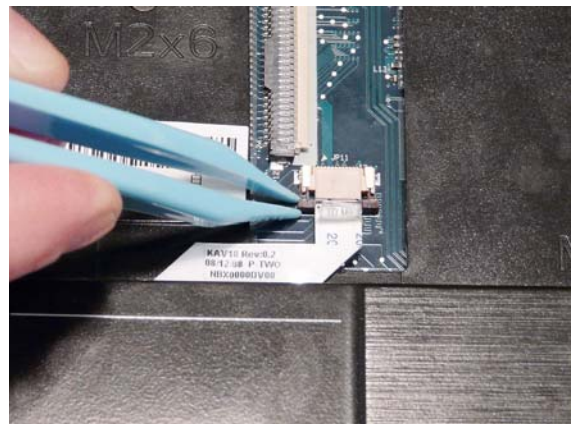

6. Turn the computer over and replace the nine securing screws as shown.

NOTE: Ensure the correct screw type is used for each hole. Red callout: M2*3, Green callout: M2*6.

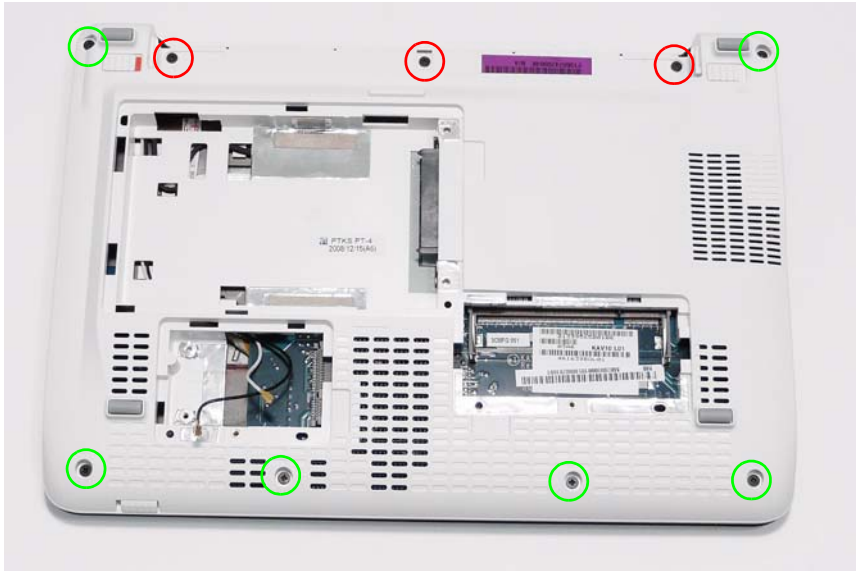

Replacing the Keyboard

1. Turn the computer over. Insert the Keyboard FFC in to the Mainboard connector.
2. Close the FFC locking latch as shown.

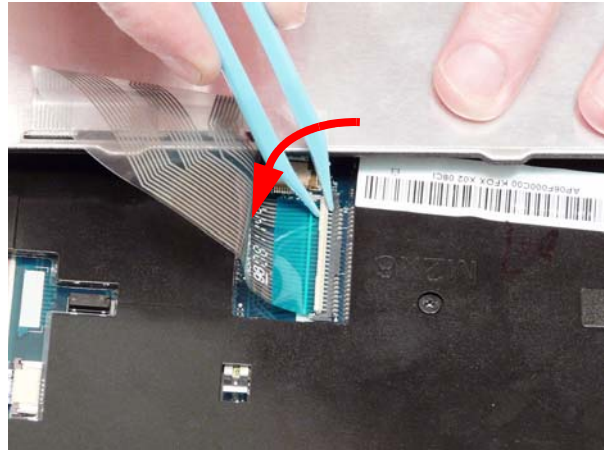
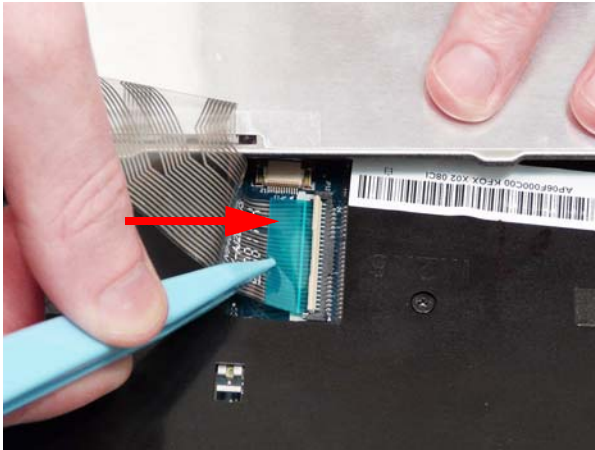

3. Turn the Keyboard over and slide it in the direction of the arrow.
4. Using the tweezers, push the locking latch in and press down in the areas indicated to secure the Keyboard.

IMPORTANT: Ensure the Keyboard slides underneath the two securing pins.



Replacing the WLAN Board

1. Turn the computer over. Insert the WLAN board in to the WLAN slot.
2. Replace the single securing screw.

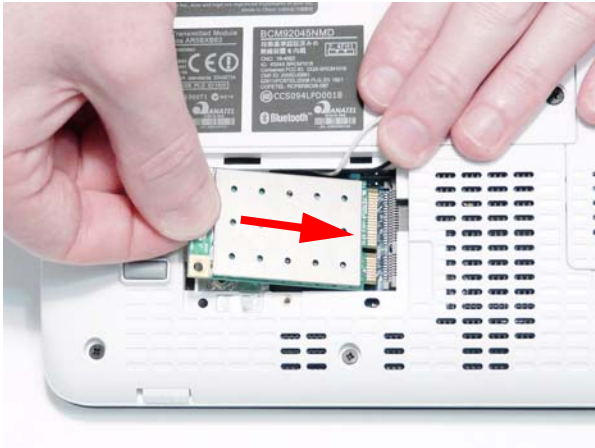

3. Connect the two Antenna cables to the WLAN board.
4. Secure the cables in place with adhesive tape.

IMPORTANT: The black cable attaches to the MAIN (J3) terminal and the gray cable attaches to the AUX (J2) terminal.



Replacing the DIMM Module

1. Insert the DIMM Module in to the DIMM slot.
2. Press the module down to complete the installation.

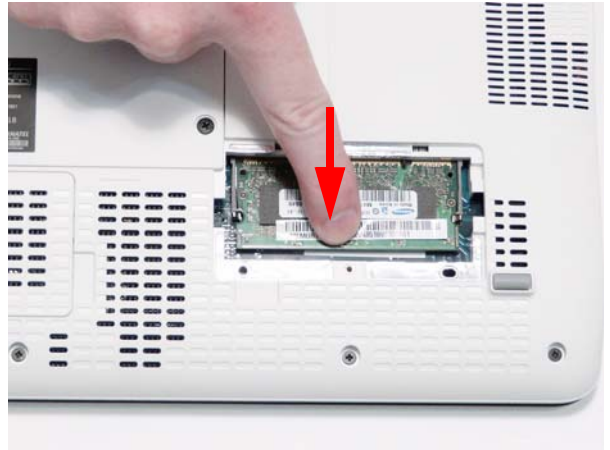
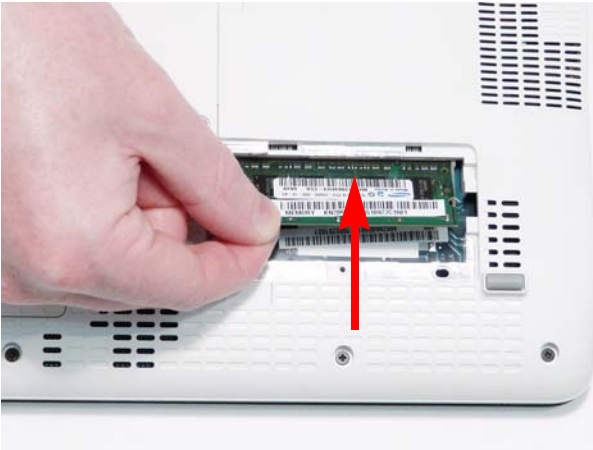

Replacing the Hard Disk Drive Module

1. Insert the HDD in to the HDD Carrier.
2. Secure the Carrier to the HDD by replacing the four screws in numerical order from 1 to 4.

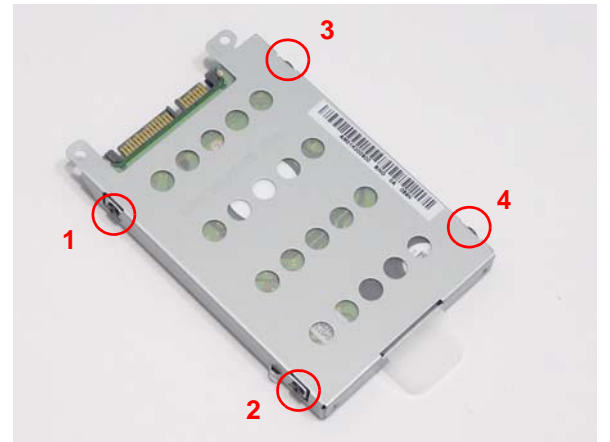
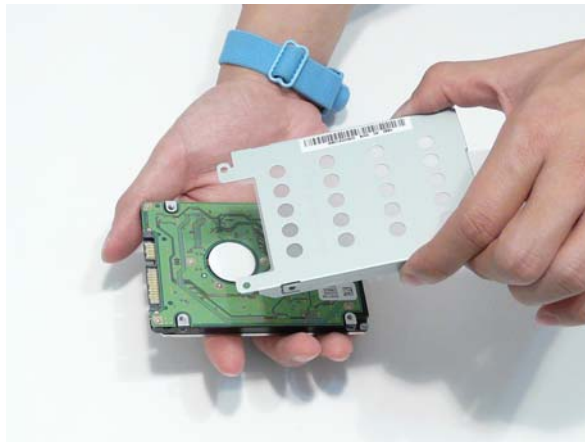

3. Insert the HDD Module into the Lower Cover as shown.
4. Slide the HDD Module in the direction of the arrow to connect the interface.



Replacing the Lower Covers

1. Replace the WLAN Cover and press down around the perimeter to snap it in to place.
2. Replace the Memory Cover and press down around the perimeter to snap it in to place.

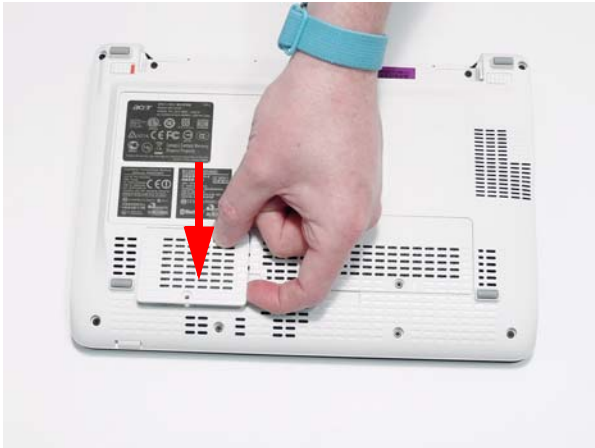

3. Replace the HDD Cover and press down around the perimeter to snap it in to place.



4. Replace the screws in the WLAN and Memory Covers and tighten the two captive screws in the HDD Cover.

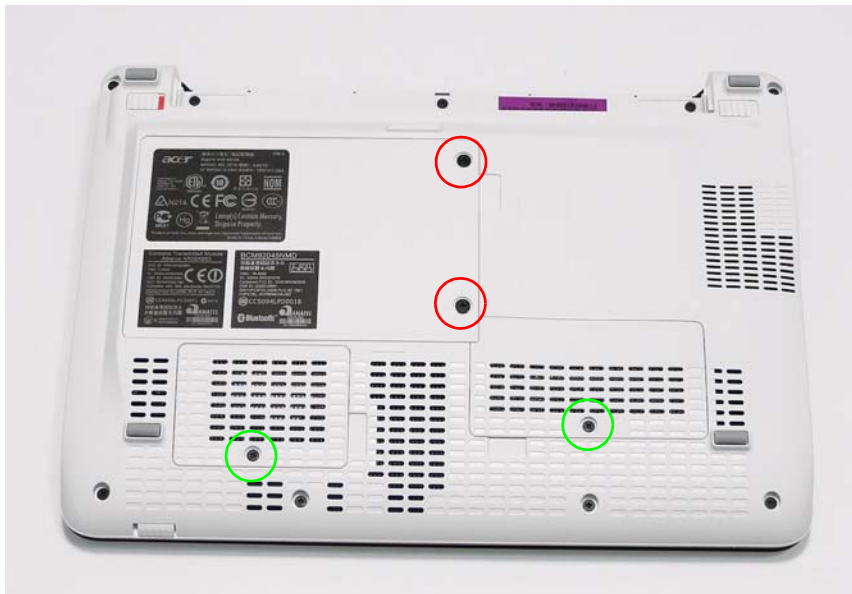

Replacing the SD Dummy Card

1. Insert the SD Dummy Card as shown.



2. Press the card in to the slot until it clicks in to place.



Replacing the Battery

1. Slide and hold the battery release latch to the release position (1), then insert the battery pack in to the main unit (2).



2. Slide the battery lock/unlock latch to the lock position.

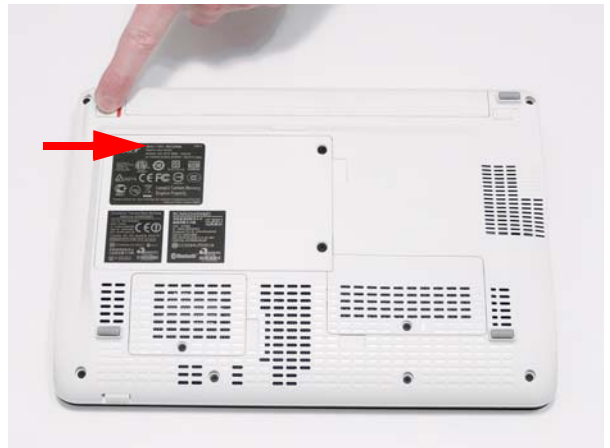

Troubleshooting

Common Problems

Use the following procedure as a guide for computer problems.

NOTE: The diagnostic tests are intended to test only Acer products. Non-Acer products, prototype cards, or modified options can give false errors and invalid system responses.

1. Obtain the failing symptoms in as much detail as possible.
2. Verify the symptoms by attempting to re-create the failure by running the diagnostic test or by repeating the same operation.
3. Use the following table with the verified symptom to determine which page to go to.

Symptoms (Verified)	Go To
Power On Issue	Page 118
No Display Issue	Page 119
LCD Failure	Page 121
Internal Keyboard Failure	Page 121
TouchPad Failure	Page 122
Internal Speaker Failure	Page 122
Internal Microphone Failure	Page 124
Rightside USB Failure	Page 126
Power Button Failure	Page 126
Other Functions Failure	Page 127
Intermittent Failures	Page 128
Undermined Failures	Page 128

4. If the Issue is still not resolved, see "Online Support Information" on page 217.

Power On Issue

If the system doesn't power on, perform the following actions one at a time to correct the problem. Do not replace a non-defective FRUs:

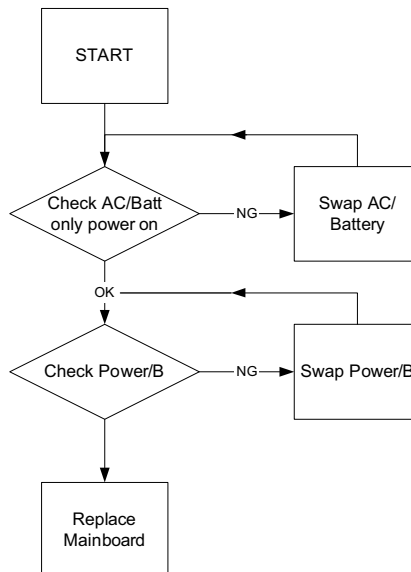

Computer Shutdown Intermittently

If the system powers off at intervals, perform the following actions one at a time to correct the problem.

1. Check the power cable is properly connected to the computer and the electrical outlet.
2. Remove any extension cables between the computer and the outlet.
3. Remove any surge protectors between the computer and the electrical outlet. Plug the computer directly into a known good electrical outlet.
4. Remove all external and non-essential hardware connected to the computer that are not necessary to boot the computer to the failure point.
5. Remove any recently installed software.
6. If the Issue is still not resolved, see "Online Support Information" on page 217.

No Display Issue

If the **Display** doesn't work, perform the following actions one at a time to correct the problem. Do not replace a non-defective FRUs:

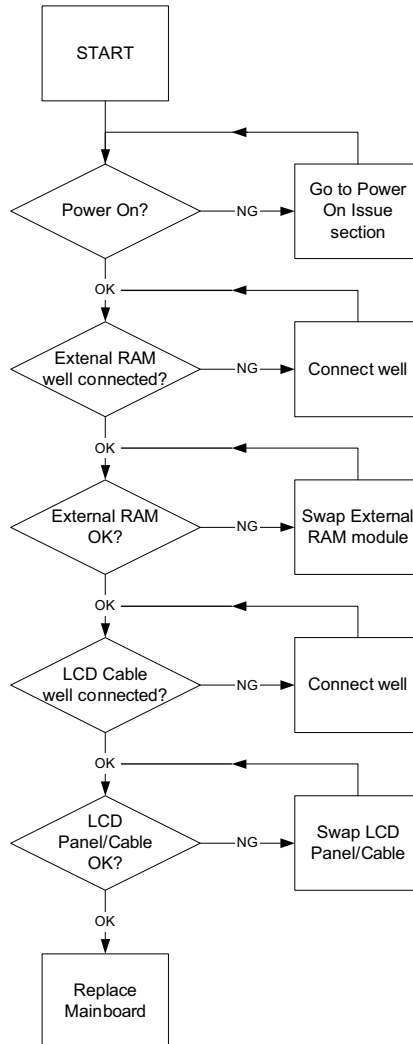

No POST or Video

If the POST or video doesn't display, perform the following actions one at a time to correct the problem.

1. Make sure that the internal display is selected. On this notebook model, switching between the internal display and the external display is done by pressing **Fn+F5**. Reference Product pages for specific model procedures.
2. Make sure the computer has power by checking at least one of the following occurs:
 - Fans start up
 - Status LEDs light up

If there is no power, see "Power On Issue" on page 118.

3. Drain any stored power by removing the power cable and battery and holding down the power button for 10 seconds. Reconnect the power and reboot the computer.
4. Connect an external monitor to the computer and switch between the internal display and the external display is by pressing **Fn+F5** (on this model).

If the POST or video appears on the external display, see “LCD Failure” on page 121.

5. Disconnect power and all external devices including port replicators or docking stations. Remove any memory cards and CD/DVD discs. Restart the computer.

If the computer boots correctly, add the devices one by one until the failure point is discovered.

6. Reseat the memory modules.
7. Remove the drives (see “Disassembly Process” on page 40).
8. If the Issue is still not resolved, see “Online Support Information” on page 217.

Abnormal Video Display

If video displays abnormally, perform the following actions one at a time to correct the problem.

1. Reboot the computer.
2. If permanent vertical/horizontal lines or dark spots display in the same location, the LCD is faulty and should be replaced. See “Disassembly Process” on page 40.
3. If extensive pixel damage is present (different colored spots in the same locations on the screen), the LCD is faulty and should be replaced. See “Disassembly Process” on page 40.
4. Adjust the brightness to its highest level. See the User Manual for instructions on adjusting settings.

NOTE: Ensure that the computer is not running on battery alone as this may reduce display brightness.

If the display is too dim at the highest brightness setting, the LCD is faulty and should be replaced. See “Disassembly Process” on page 40.

5. Check the display resolution is correctly configured:
 - a. Minimize or close all Windows.
 - b. If display size is only abnormal in an application, check the view settings and control/mouse wheel zoom feature in the application.
 - c. If desktop display resolution is not normal, right-click on the desktop and select **Personalize** → **Display Settings**.
 - d. Click and drag the Resolution slider to the desired resolution.
 - e. Click **Apply** and check the display. Readjust if necessary.
6. Roll back the video driver to the previous version if updated.
7. Remove and reinstall the video driver.
8. Check the Device Manager to determine that:
 - The device is properly installed. There are no red Xs or yellow exclamation marks.
 - There are no device conflicts.
 - No hardware is listed under Other Devices.
9. If the Issue is still not resolved, see “Online Support Information” on page 217.
10. Run the Windows Memory Diagnostic from the operating system DVD and follow the onscreen prompts.
11. If the Issue is still not resolved, see “Online Support Information” on page 217.

Random Loss of BIOS Settings

If the computer is experiencing intermittent loss of BIOS information, perform the following actions one at a time to correct the problem.

1. If the computer is more than one year old, replace the CMOS battery.
2. Run a complete virus scan using up-to-date software to ensure the computer is virus free.
3. If the computer is experiencing HDD or ODD BIOS information loss, disconnect and reconnect the power and data cables between devices.

If the BIOS settings are still lost, replace the cables.

4. If HDD information is missing from the BIOS, the drive may be defective and should be replaced.
5. Replace the Motherboard.
6. If the Issue is still not resolved, see “Online Support Information” on page 217.

LCD Failure

If the **LCD** fails, perform the following actions one at a time to correct the problem. Do not replace a non-defective FRUs:

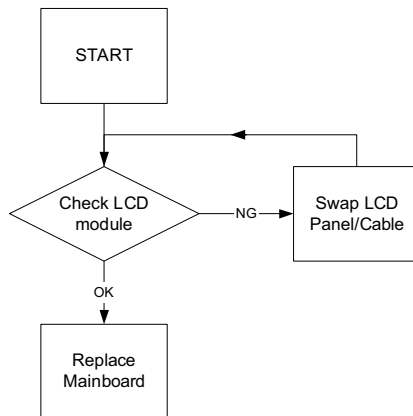

Built-In Keyboard Failure

If the built-in **Keyboard** fails, perform the following actions one at a time to correct the problem. Do not replace a non-defective FRUs:

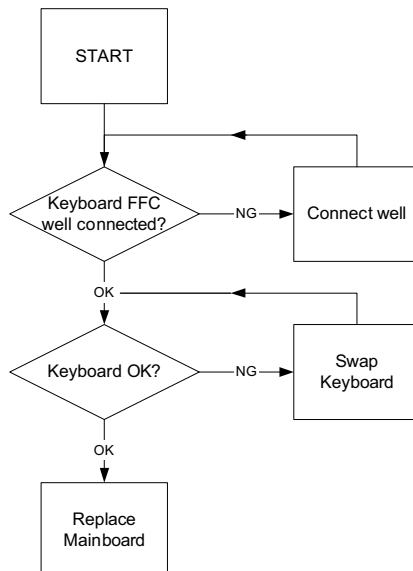

TouchPad Failure

If the **TouchPad** doesn't work, perform the following actions one at a time to correct the problem. Do not replace a non-defective FRUs:

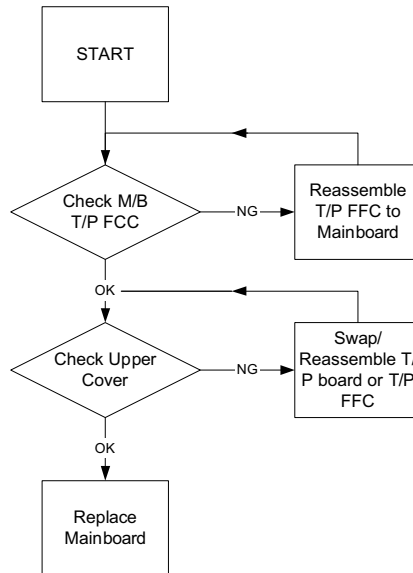

Internal Speaker Failure

If the internal **Speakers** fail, perform the following actions one at a time to correct the problem. Do not replace a non-defective FRUs:

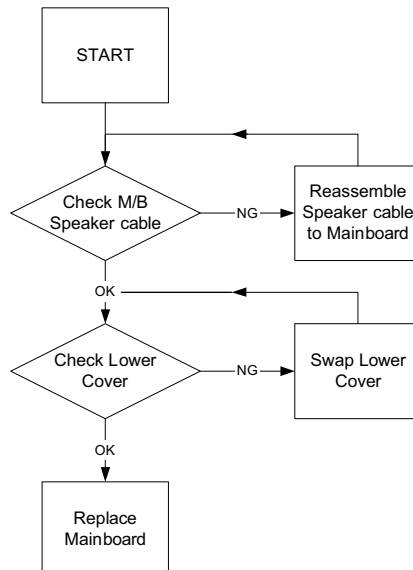

Sound Problems

If sound problems are experienced, perform the following actions one at a time to correct the problem.

1. Reboot the computer.
2. Navigate to **Start** → **Control Panel** → **System and Maintenance** → **System** → **Device Manager**. Check the Device Manager to determine that:

-
- The device is properly installed.
 - There are no red Xs or yellow exclamation marks.
 - There are no device conflicts.
 - No hardware is listed under Other Devices.
3. Roll back the audio driver to the previous version, if updated recently.
 4. Remove and reinstall the audio driver.
 5. Ensure that all volume controls are set mid range:
 - a. Click the volume icon on the taskbar and drag the slider to 50. Ensure that the volume is not muted.
 - b. Click Mixer to verify that other audio applications are set to 50 and not muted.
 6. Navigate to **Start** → **Control Panel** → **Hardware and Sound** → **Sound**. Ensure that Speakers are selected as the default audio device (green check mark).

NOTE: If Speakers does not show, right-click on the **Playback** tab and select **Show Disabled Devices** (clear by default).
 7. Select Speakers and click **Configure** to start **Speaker Setup**. Follow the onscreen prompts to configure the speakers.
 8. Remove and recently installed hardware or software.
 9. Restore system and file settings from a known good date using **System Restore**.

If the issue is not fixed, repeat the preceding steps and select an earlier time and date.
 10. Reinstall the Operating System.
 11. If the Issue is still not resolved, see “Online Support Information” on page 217.

Internal Microphone Failure

If the internal **Microphone** fails, perform the following actions one at a time to correct the problem. Do not replace a non-defective FRUs:

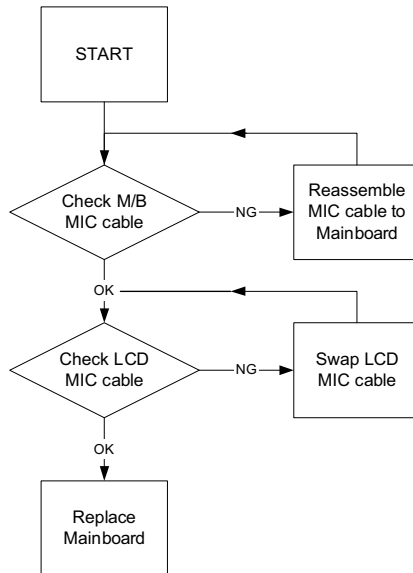

Microphone Problems

If internal or external **Microphones** do not operate correctly, perform the following actions one at a time to correct the problem.

1. Check that the microphone is enabled. Navigate to **Start** → **Control Panel** → **Hardware and Sound** → **Sound** and select the **Recording** tab.
2. Right-click on the **Recording** tab and select **Show Disabled Devices** (clear by default).
3. The microphone appears on the **Recording** tab.
4. Right-click on the microphone and select **Enable**.
5. Select the microphone then click **Properties**. Select the **Levels** tab.
6. Increase the volume to the maximum setting and click **OK**.
7. Test the microphone hardware:
 - a. Select the microphone and click **Configure**.
 - b. Select **Set up microphone**.
 - c. Select the microphone type from the list and click **Next**.
 - d. Follow the onscreen prompts to complete the test.
8. If the Issue is still not resolved, see "Online Support Information" on page 217.

HDD Not Operating Correctly

If the **HDD** does not operate correctly, perform the following actions one at a time to correct the problem.

1. Disconnect all external devices.
2. Run a complete virus scan using up-to-date software to ensure the computer is virus free.
3. Run the Windows Vista Startup Repair Utility:
 - a. insert the Windows Vista Operating System DVD in the ODD and restart the computer.
 - b. When prompted, press any key to start to the operating system DVD.
 - c. The **Install Windows** screen displays. Click **Next**.
 - d. Select **Repair your computer**.
 - e. The **System Recovery Options** screen displays. Click **Next**.
 - f. Select the appropriate operating system, and click **Next**.

NOTE: Click **Load Drivers** if controller drives are required.

- g. Select **Startup Repair**.
- h. Startup Repair attempts to locate and resolve issues with the computer.
- i. When complete, click **Finish**.

If an issue is discovered, follow the onscreen information to resolve the problem.

4. Run the Windows Memory Diagnostic Tool. For more information see Windows Help and Support.
5. Restart the computer and press F2 to enter the BIOS Utility. Check the BIOS settings are correct and that CD/DVD drive is set as the first boot device on the Boot menu.
6. Ensure all cables and jumpers on the HDD and ODD are set correctly.
7. Remove any recently added hardware and associated software.
8. Run the Windows Disk Defragmenter. For more information see Windows Help and Support.
9. Run Windows Check Disk by entering **chkdsk /r** from a command prompt. For more information see Windows Help and Support.
10. Restore system and file settings from a known good date using **System Restore**.

If the issue is not fixed, repeat the preceding steps and select an earlier time and date.
11. Replace the HDD. See "Disassembly Process" on page 40.

USB Failure (Rightside)

If the rightside **USB** port fails, perform the following actions one at a time to correct the problem. Do not replace a non-defective FRUs:

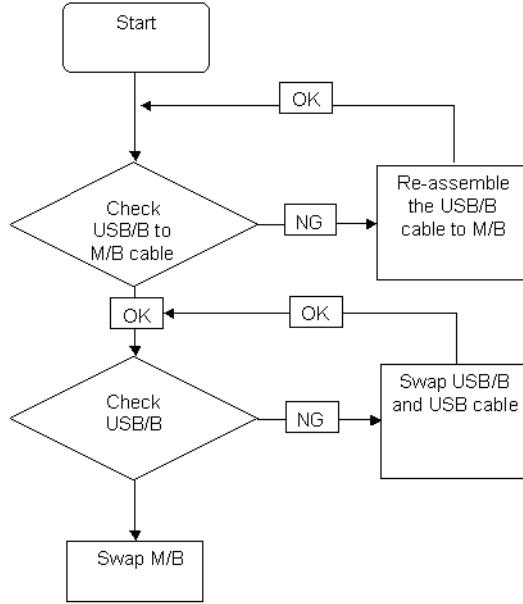

Power Button Failure

If the Power Button fails, perform the following actions one at a time to correct the problem. Do not replace a non-defective FRUs:

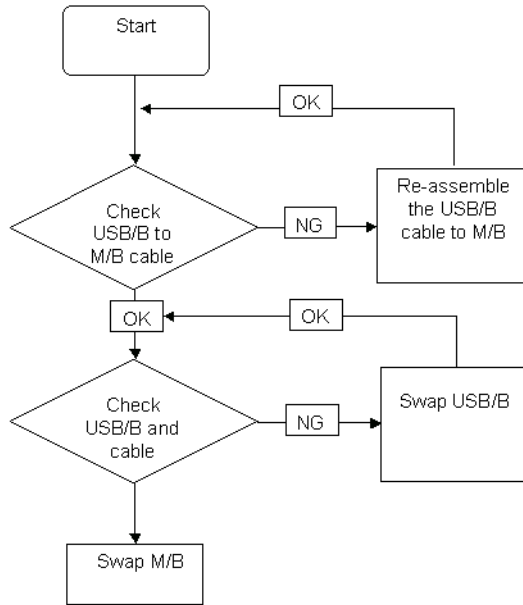

External Mouse Failure

If an external **Mouse** fails, perform the following actions one at a time to correct the problem.

1. Try an alternative mouse.
2. If the mouse uses a wireless connection, insert new batteries and confirm there is a good connection. See the mouse user manual.
3. If the mouse uses a USB connection, try an alternate USB port.
4. Try an alternative program to verify mouse operation. Reinstall the program experiencing mouse failure.
5. Restart the computer.
6. Remove any recently added hardware and associated software.
7. Remove any recently added software and reboot.
8. Restore system and file settings from a known good date using **System Restore**.
If the issue is not fixed, repeat the preceding steps and select an earlier time and date.
9. Run the Event Viewer to check the events log for errors. For more information see Windows Help and Support.
10. Roll back the mouse driver to the previous version if updated recently.
11. Remove and reinstall the mouse driver.
12. Check the Device Manager to determine that:
 - The device is properly installed. There are no red Xs or yellow exclamation marks.
 - There are no device conflicts.
 - No hardware is listed under Other Devices.
13. If the Issue is still not resolved, see "Online Support Information" on page 217.

Other Failures

If the CRT Switch, Dock, LAN Port, external MIC or Speakers, PCI Express Card, 5-in-1 Card Reader or Volume Wheel fail, perform the following general steps to correct the problem. Do not replace a non-defective FRUs:

1. Check Drive whether is OK.
2. Check Test Fixture is ok.
3. Swap M/B to Try.

Intermittent Problems

Intermittent system hang problems can be caused by a variety of reasons that have nothing to do with a hardware defect, such as: cosmic radiation, electrostatic discharge, or software errors. FRU replacement should be considered only when a recurring problem exists.

When analyzing an intermittent problem, do the following:

1. Run the advanced diagnostic test for the system board in loop mode at least 10 times.
2. If no error is detected, do not replace any FRU.
3. If any error is detected, replace the FRU. Rerun the test to verify that there are no more errors.

Undetermined Problems

The diagnostic problems does not identify which adapter or device failed, which installed devices are incorrect, whether a short circuit is suspected, or whether the system is inoperative.

Follow these procedures to isolate the failing FRU (do not isolate non-defective FRU).

NOTE: Verify that all attached devices are supported by the computer.

NOTE: Verify that the power supply being used at the time of the failure is operating correctly. (See “Power On Issue” on page 118):

1. Power-off the computer.
2. Visually check them for damage. If any problems are found, replace the FRU.
3. Remove or disconnect all of the following devices:
 - Non-Acer devices
 - Printer, mouse, and other external devices
 - Battery pack
 - Hard disk drive
 - DIMM
 - CD-ROM/Diskette drive Module
 - PC Cards
4. Power-on the computer.
5. Determine if the problem has changed.
6. If the problem does not recur, reconnect the removed devices one at a time until you find the failing FRU.
7. If the problem remains, replace the following FRU one at a time. Do not replace a non-defective FRU:
 - System board
 - LCD assembly

POST Code Reference Tables

These tables describe the POST codes and components of the POST process.

Sec:

NO_EVICTION_MODE_DEBUG EQU 1 (CommonPlatform\sec\ia32\SecCore.inc)

Code	Description
0xC2	MTRR setup
0xC3	Enable cache
0xC4	Establish cache tags
0xC5	Enter NEM, Place the BSP in No Fill mode, set CR0.CD = 1, CR0.NW = 0.
0xCF	Cache Init Finished

Memory:

DEBUG_BIOS equ 1 (Chipset\Alviso\MemoryInitAsm\IA32\IMEMORY.INC)

Code	Description
0xA0	First memory check point
0x01	Enable MCHBAR
0x02	Check for DRAM initialization interrupt and reset fail
0x03	Verify all DIMMs are DDR or DDR2 and unbuffered
0x04	Detect an improper warm reset and handle
0x05	Detect if ECC SO-DIMMs are present in the system
0x06	Verify all DIMMs are single or double sided and not asymmetric
0x07	Verify all DIMMs are x8 or x16 width
0x08	Find a common CAS latency between the DIMMS and the MCH
0x09	Determine the memory frequency and CAS latency to program
0x10	Determine the smallest common TRAS for all DIMMs
0x11	Determine the smallest common TRP for all DIMMs
0x12	Determine the smallest common TRCD for all DIMMs
0x13	Determine the smallest refresh period for all DIMMs
0x14	Verify burst length of 8 is supported by all DIMMs
0x15	Determine the smallest tWR supported by all DIMMs
0x16	Determine DIMM size parameters
0x17	Program the correct system memory frequency
0x18	Determine and set the mode of operation for the memory channels
0x19	Program clock crossing registers
0x20	Disable Fast Dispatch
0x21	Program the DRAM Row Attributes and DRAM Row Boundary registers
0x22	Program the DRAM Bank Architecture register
0x23	Program the DRAM Timing & and DRAM Control registers
0x24	Program ODT
0x25	Perform steps required before memory init
0x26	Program the receive enable reference timing control register Program the DLL Timing Control Registers, RCOMP settings

Code	Description
0x27	Enable DRAM Channel I/O Buffers
0x28	Enable all clocks on populated rows
0x29	Perform JEDEC memory initialization for all memory rows
0x30	Perform steps required after memory init
0x31	Program DRAM throttling and throttling event registers
0x32	Setup DRAM control register for normal operation and enable
0x33	Enable RCOMP
0x34	Clear DRAM initialization bit in the SB
0x35	Initialization Sequence Completed, program graphic clocks
0x43	Program Thermal Throttling

BDS & Specific action:

Code	Description
0x00	Report the legacy boot is happening
0x12	Wake up the Aps
0x13	Initialize SMM Private Data and relocate BSP SMBASE
0x21	PC init begin at the stage1
0x27	Report every memory range do the hard ware ECC init
0x28	Report status code of every memory range
0x50	Get the root bridge handle
0x51	Notify pci bus driver starts to program the resource
0x58	Reset the host controller
0x5A	IdeBus begin initialization
0x79	Report that the remote terminal is being disabled
0x7A	Report that the remote terminal is being enabled
0x90	Keyboard reset
0x91	USB Keyboard disable
0x92	Keyboard detection
0x93	Report that the usb keyboard is being enabled
0x94	Clear the keyboard buffer
0x95	Init Keyboard
0x98	Mouse reset
0x99	Mouse disable
0x9A	Detect PS2 mouse
0x9B	Report that the mouse is being enabled
0xB8	Peripheral removable media reset (ex: IsaFloppy, USB device)
0xB9	Peripheral removable media disable
0xBB	Peripheral removable media enable
0xE4	Report Status Code here for DXE_ENTRY_POINT once it is available
0xF8	Report that ExitBootServices () has been called
0xF9	Runtime driver set virtual address map

Each PEIM entry point used in 80_PORT

Code	Description
0x00	
0x01	PEI_EVENT_LOG
0xA1	PEI_OEM_SERVICE
0xA2	PEI_SIO_INIT
0xA3	PEI_MONO_STATUS_CODE
0xA4	PEI_CPU_IO_PCI_CFG
0x06	PEI_CPU_IO
0x07	PEI_PCI_CFG
0xA5	PEI_CPU_PEIM
0xA6	PEI_PLATFORM_STAGE1
0xA7	PEI_VARIABLE
0xA8	PEI_SB_INIT
0x0C	PEI_CAPSULE
0xAA	PEI_PLATFORM_STAGE2
0xAC	PEI_SB_SMBUS_ARP_DISABLED
0x0F	PEI_HOST_TO_SYSTEM
0x40	PEI_MEMORY_INIT
0x41	PEI_S3_RESUME
0xAD	PEI_CLOCK_GEN
0xAB	PEI_OP_PRESENCE
0xAE	PEI_FIND_FV
0x16	PEI_H2O_DEBUG_IO
0x17	PEI_H2O_DEBUG_COMM
0x16~0x1F	PEI_RESERVED
0x20~0x2E	PEI_OEM_DEFINED
0xAF	PEI_DXE_IPL

Each Driver entry point used in 80_PORT

Code	Description
0x30	RESERVED
0xB6	DXE_CRC32_SECTION_EXTRACT
0xB8	SCRIPT_SAVE
0xB9	ACPI_S3_SAVE
0xBA	SMART_TIMER
0xBB	JPEG_DECODER
0xBC	PCX_DECODER
0xBE	HT_CPU / MP_CPU
0xBF	LEGACY_METRONOME
0xC0	FTWLITE
0xC1	RUN_RIME
0xC2	MONOTONIC_COUNTER
0xC3	WATCH_DOG_TIMER

Code	Description
0xC4	SECURITY_STUB
0xC5	DXE_CPU_IO
0xC6	CF9_RESET
0xC7	PC_RTC
0xC8	STATUS_CODE
0xC9	VARIABLE EMU_VARIABLE
0xD9	DXE_CHIPSET_INIT
0x45	DXE_ALERT_FORMAT
0xD6	PCI_HOST_BRIDGE
0xD7	PCI_EXPRESS
0xD5	DXE_SB_INIT
0xDA	IDE_CONTROLLER
0xDB	SATA_CONTROLLER
0xDD	SB_SM_BUS
0xE7	ISA_ACPI_DRIVER
0xE8	ISA_BUS
0xE9	ISA_SERIAL
0xED	BUS_PCI_UNDI
0xEC	PCI_BUS
0xF6	BOOT_PRIORITY
0xF7	FVB_SERVICE
0xF8	ACPI_PLATFORM
0xFB	PCI_HOT_PLUG
0xFC	DXE_PLATFORM
0xFD	PLATFORM_IDE
0x97	SMBIOS
0x98	MEMORY_SUB_CLASS
0x99	MISC_SUB_CLASS
0x82	CON_PLATFORM
0x83	SAVE_MEMORY_CONFIG
0x84	ACPI_SUPPORT
0x85	CON_SPLITTER_UGA_VGA / CON_SPLITTER
0x88	VGA_CLASS
0x89	DATA_HUB
0x60	DISK_IO
0x8B	MEMORY_TEST
0x62	CRISIS_RECOVERY
0x8D	LEGACY_8259
0x8E	LEGACY_REGION
0x8F	LEGACY_INTERRUPT
0x70	BIOS_KEYBOARD
0x71	BIOS_VEDIO
0x72	MONITER_KEY

Code	Description
0x73	LEGACY_BIOS
0x75	LEGACY_BIOS_PLATFORM
0x76	PCI_PLATFORM
0x6C	ISA_FLOOPY
0x6D	PS2_MOUSE
0x6E	USB_BOT
0x6F	USB_CBIO
0x74	USB_MOUSE
0xFA	SETUP_UTILITY
0x90	FW_BLOCK_SERVICE
0x78	SMM_USB_LEGACY
0x86	GRAPHICS_CONSOLE
0x87	TERMINAL
0x8A	DATA_HUB_STD_ERR
0x7C	FAT
0x7D	PARTITION
0x7E	ENGLISH
0x7F	FRENCH
0x9E	HII_DATABASE
0x9F	OEM_SETUP_BROWSER
0x8C	OEM_BADGING_SUPPORT
0xF9	SETUP_MOUSE
0x72	MONITOR_KEY
0xBD	PLATFORM_BDS
0x8D	RESERVED
0x8E	RESERVED
0x8F	RESERVED
0xA0	DXE_H2O_DEBUG_IO
0xB3	DXE_TPM_TCG
0xB4	DXE_TPM_PHYSICAL_PRESENCE
0xB7	DXE_OEM_SERVICE
0x9B	DXE_SECURITY_HDD_PASSWORD_SERVICE
0xA9	DXE_LAN_IDER_CONTROLLER
0x9C	DXE_SECURITY_SYSTEM_PASSWORD_SERVICE
0x9D	DXE_SECURITY_PASSWORD_CONSOLE
0xCB	DXE_DATA_HUB_RECORD_POLICY
0xB5	DXE_TPM_DRIVER
0x11	CHINESE
0xB0	JAPANESE
0xB1	DXE_UNICODE_COLLATION

Each SmmDriver entry point used in 80_PORT

Code	Description
0xD4	SMM_ACCESS
0xDE	SMM_CONTROL
0xCC	SMM_BASE
0xD2	SMM_RUNTIME
0xDF	SB_SMM_DISPATCH
0xD0	SMM_THUNK
0xCA	SMM_ACPI_SW_CHILD
0xFE	SMM_PLATFORM
0xD8	SMM_GMCH_MBI
0x90	SMM_FW_BLOCK_SERVICE
0x91	SMM_VARIABLE
0x92	SMM_IHISI
0x93	SMM_INT15_MICROCODE
0x94	SMM_PNP
0x95	SMM_INIT_PPM
0xD3	SMM_OEM_SERVICE

Jumper and Connector Locations

Top View

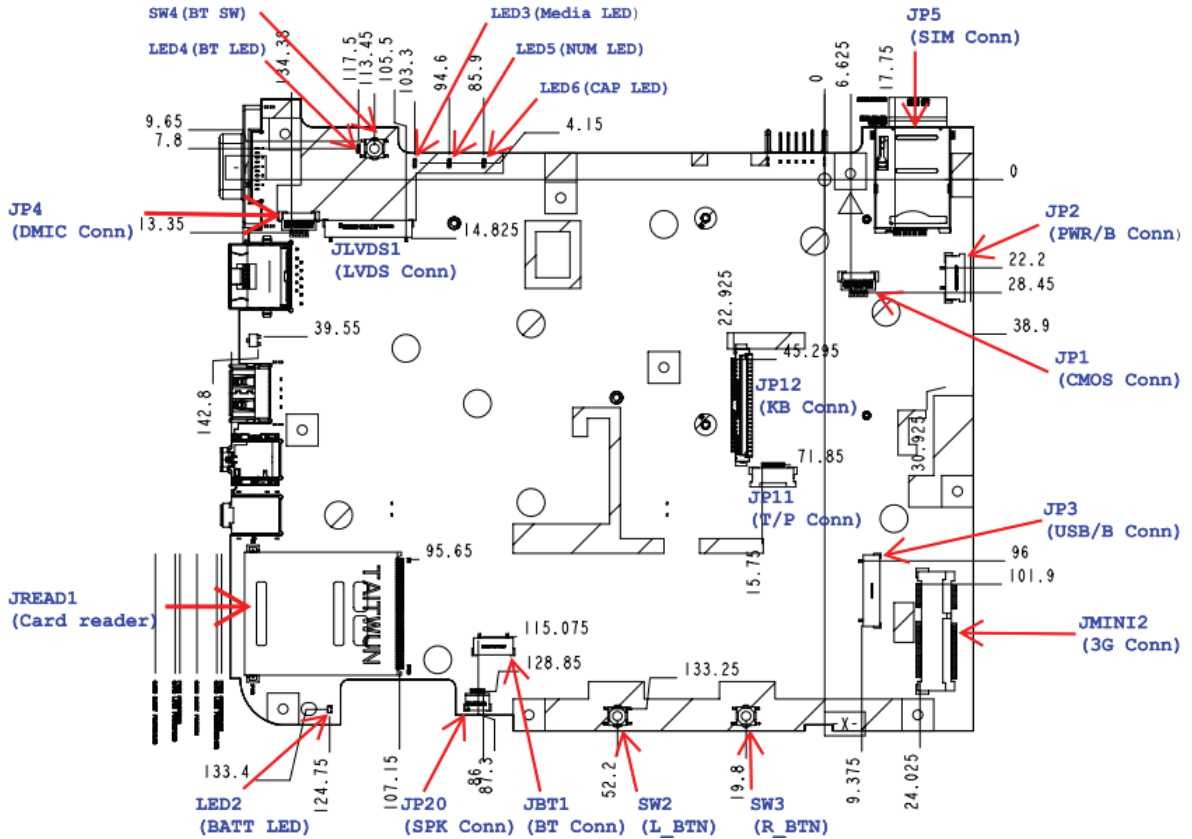

Item	Description	Item	Description
JP1	Internal camera Connector	JBT1	Bluetooth Connector
JP2	TO PWR/B Connector	JMINI2	MINI Card (3G) Socket
JP3	TO USB/B Connector	SW2	Left Button
JP4	Internal DMIC Connector	SW3	Right Button
JP5	SIM Card Connector	SW4	Bluetooth Button
JP11	Internal TouchPad Connector	LED2	Battery LED
JP12	Internal Keyboard Connector	LED3	Media LED
JP20	Speaker Connector	LED4	Bluetooth LED
JLVD51	LCD Connector	LED5	NUM LED
JREAD1	Card Reader Connector	LED6	CAP LED

Bottom View

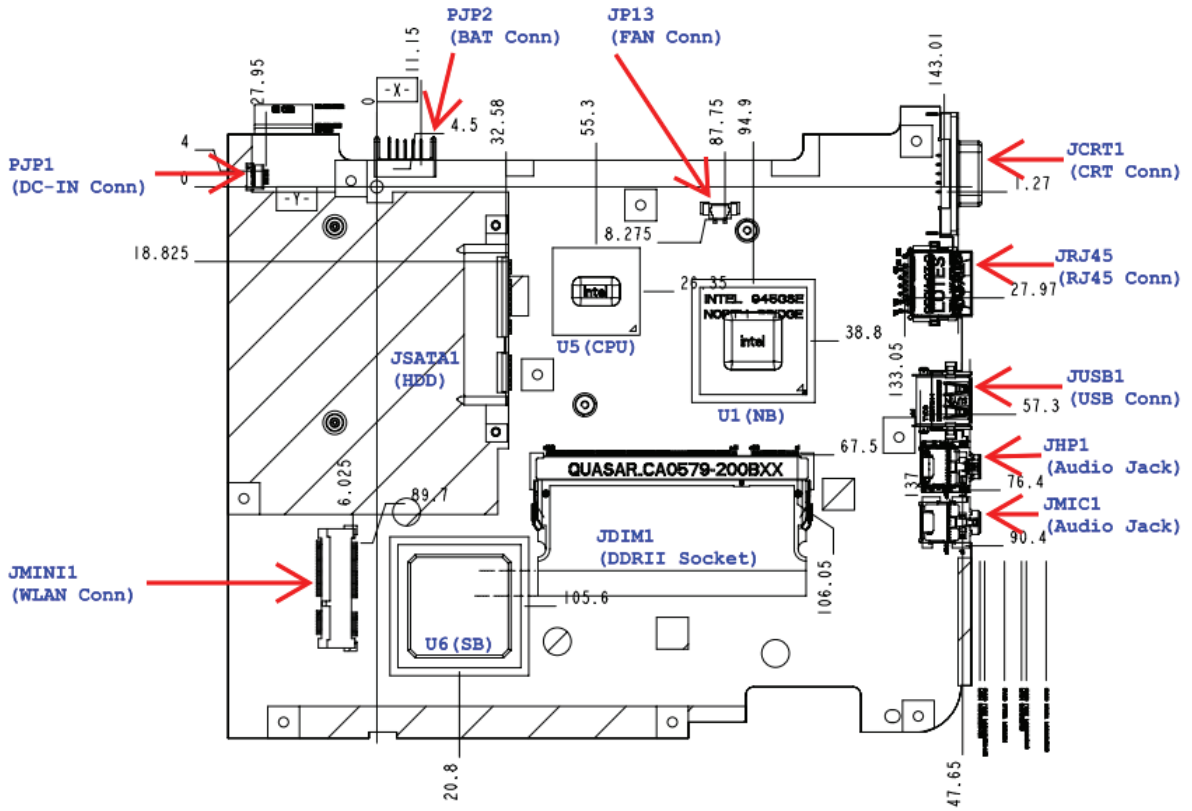

Item	Description	Item	Description
JDIM1	DDR2 Socket	JMIC1	MIC IN Connector
JSATA1	HDD Connector	JP13	FAN Connector
JMINI1	MINI Card (Wireless) Socket	PJP1	TO Power Core Connector
JCRT1	CRT Connector	PJP2	Battery Connector
JRJ451	RJ45 LAN Connector	U1	NB
JUSB1	External USB Connector	U5	CPU
JHP1	Head-Phone Connector	U6	SB

Clearing Password Check and BIOS Recovery

This section provide you the standard operating procedures of clearing password and BIOS recovery for Aspire one. Aspire one provides one Hardware Open Gap on main board for clearing password check, and one Hotkey for enabling BIOS Recovery.

Clearing Password Check

Hardware Open Gap Description

Item	Description	Location
R72	Clear CMOS Jumper	Memory Bay

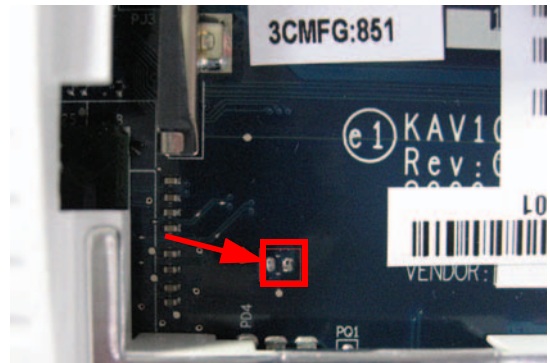
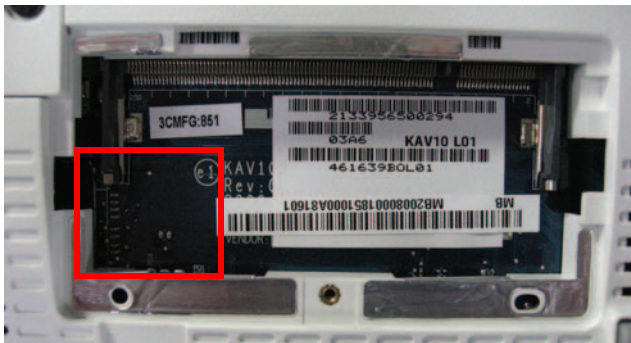

Steps for Clearing BIOS Password Check

If users set BIOS Password (Supervisor Password and/or User Password) for a security reason, BIOS will ask the password during systems POST or when systems enter to BIOS Setup menu. However, once it is necessary to bypass the password check, users need to short the HW Gap to clear the password by the following steps:

1. Flash to BIOS v1.04 (or later version), and enter BIOS Setup Utility.
2. Set the Supervisor password, User Password, and power on password. Press **F10**, and save and exit.
After the Save, the notebook auto re-starts.
3. After power-on, the system prompts to input the password. Enter the password set in step 1 and allow the device to startup.
4. Press and hold the power key to shutdown the system.
5. Open the memory door and remove the memory modules.
6. Remove the battery pack and AC adapter.
7. Short the R72 Pins shown above (ensure that the circuit is complete).
8. Replace the memory modules and close memory door.
9. Replace the battery pack and power on the system.
10. Press **F2** at the prompt to enter BIOS. Check the **Security** screen shows Supervisor and User Passwords are clear.

BIOS Recovery by Crisis Disk

BIOS Recovery Boot Block:

BIOS Recovery Boot Block is a special block of BIOS. It is used to boot up the system with minimum BIOS initialization. Users can enable this feature to restore the BIOS firmware to a successful one once the previous BIOS flashing process failed.

BIOS Recovery Hotkey:

The system provides a function hotkey: **Fn+Esc**, for enable BIOS Recovery process when system is powered on during BIOS POST. To use this function, it is strongly recommended to have the AC adapter and Battery present. If this function is enabled, the system will force the BIOS to enter a special BIOS block, called Boot Block.

Steps for BIOS Recovery from USB Storage:

Before doing this, prepare the Crisis USB key. The Crisis USB key could be made by executing the Crisis Disk program in another system with Windows XP OS.

Follow the steps below:

1. Save ROM file (file name: **JAL90x64.fd**) to the root directory of USB storage.
2. Plug USB storage into USB port.
3. Press **Fn + ESC** button then plug in AC.
The Power button flashes once.
4. Press **Power** button to initiate system CRISIS mode.
When CRISIS is complete, the system auto restarts with a workable BIOS.
5. Update the latest version BIOS for this machine by regular BIOS flashing process.

FRU (Field Replaceable Unit) List

This chapter gives you the FRU (Field Replaceable Unit) listing in global configurations of Aspire one. Refer to this chapter whenever ordering for parts to repair or for RMA (Return Merchandise Authorization).

Please note that WHEN ORDERING FRU PARTS, you should check the most up-to-date information available on your regional web or channel. For whatever reasons a part number change is made, it will not be noted on the printed Service Guide. For ACER AUTHORIZED SERVICE PROVIDERS, your Acer office may have a DIFFERENT part number code from those given in the FRU list of this printed Service Guide. You MUST use the local FRU list provided by your regional Acer office to order FRU parts for repair and service of customer machines.

NOTE: To scrap or to return the defective parts, you should follow the local government ordinance or regulations on how to dispose it properly, or follow the rules set by your regional Acer office on how to return it.

Aspire one Exploded Diagrams

Main Assembly

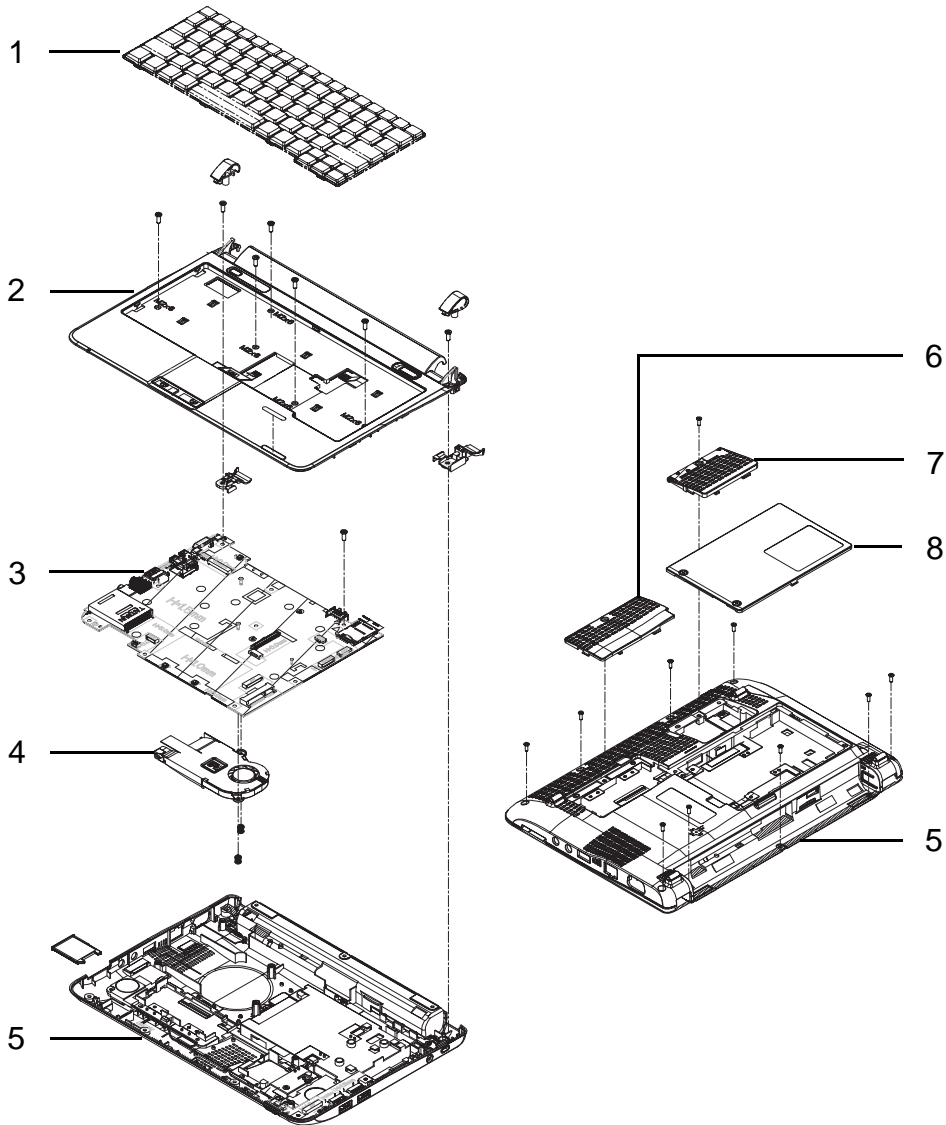

Item	Description	Part Number
1	Keyboard	TBD
2	Upper Cover	60.S5702.001
3	Mainboard	MB.S6102.001
4	Heatsink	60.S5502.005
5	Lower Cover	60.S5502.001
6	Memory Door	42.S5502.003
7	WLAN Door	42.S5502.005
8	HDD Door	42.S5502.004

Upper Cover Assembly

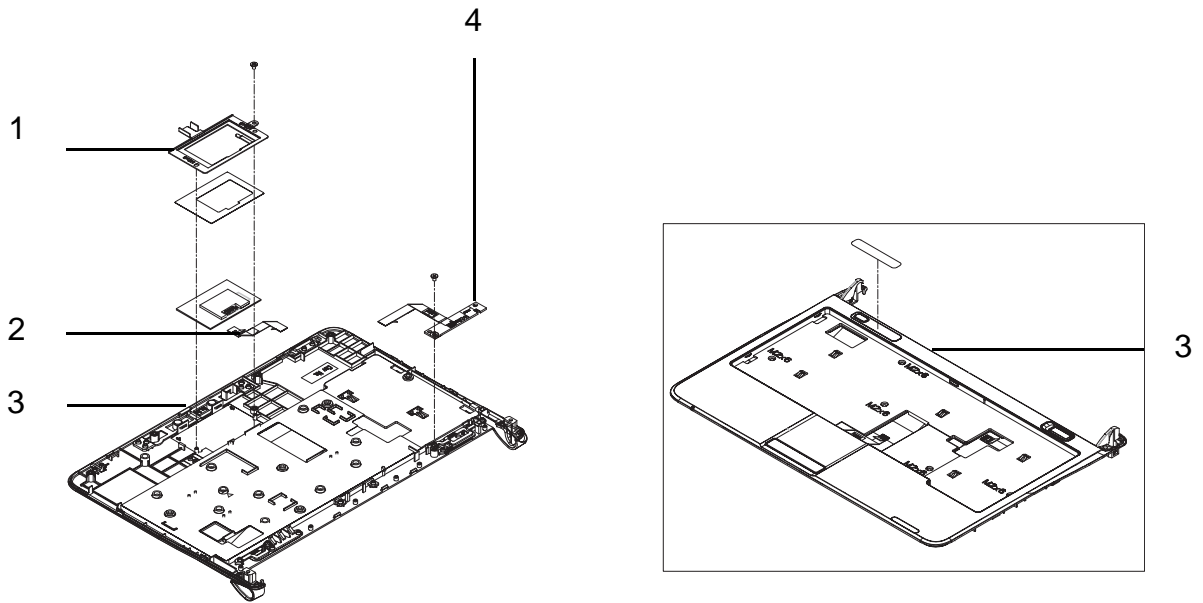

Item	Description	Part Number
1	TouchPad Bracket	33.S5502.001
2	TouchPad FFC Cable	50.S5502.004
3	Upper Cover	60.S5702.001
4	Power Board	55.S5502.002

Lower Cover Assembly

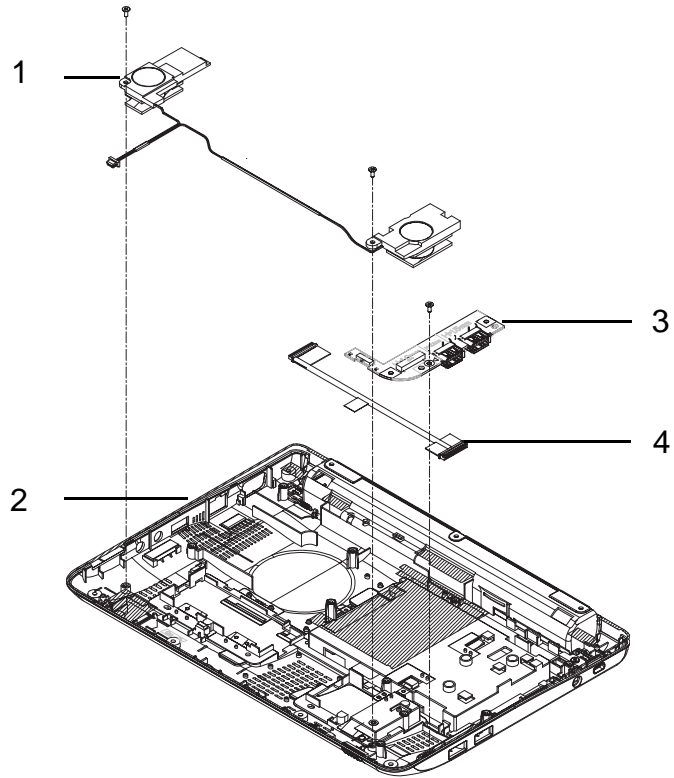

Item	Description	Part Number
1	Speaker Module	23.S5502.002
2	Lower Cover	60.S5502.001
3	USB Board	55.S5502.001
4	USB Cable	50.S5502.002

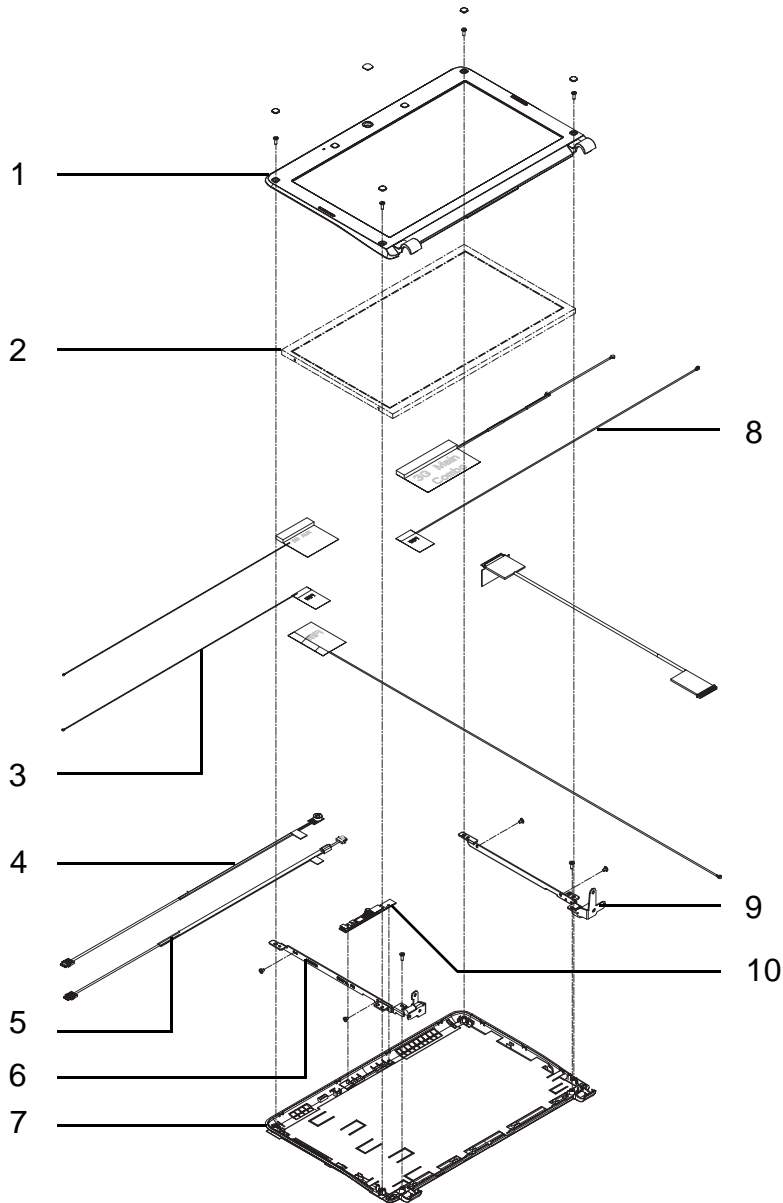

LCD Assembly



Item	Description	Part Number	Item	Description	Part Number
1	LCD Bezel	60.S5502.004	6	LCD Bracket_L	33.S5502.003
2	LCD Panel	6M.S5502.001	7	LCD Module	60.S5502.003
3	ANTENNA WL-AUX	50.S5502.006	8	ANTENNA WL-MAIN	50.S5502.005
4	MIC Module	6M.S5502.001	9	LCD Bracket_R	33.S5502.003
5	Camera Cable	50.S5502.008	10	Camera Module	57.S5502.001

Aspire one FRU List

Category	Description	Acer PN
Adapter		
	Adapter DELTA 30W 19V 1.7x5.5x11 Black ADP-30JH BA LF	AP.03001.001
	Adapter LITE-ON 30W 19V 1.7x5.5x11 Black PA-1300-04AC LF	AP.03003.001
	Adapter HIPRO 30W 19V 1.7x5.5x11 Black HP-A0301R3 B1LF LF	AP.0300A.001
Battery		
	Battery SANYO UM-2008A Li-Ion 3S1P SANYO 3 cell 2200mAh Main COMMON Macles	BT.00303.008
	Battery SANYO UM-2008AW Li-Ion 3S1P SANYO 3 cell 2200mAh Main COMMON Macles / White	BT.00303.009
	Battery PANASONIC UM-2008A Li-Ion 3S1P PANASONIC 3 cell 2200mAh Main COMMON Macles	BT.00305.005
	Battery PANASONIC UM-2008AW Li-Ion 3S1P PANASONIC 3 cell 2200mAh Main COMMON Macles / White	BT.00305.006
	Battery SIMPLO UM-2008A Li-Ion 3S1P SAMSUNG 3 cell 2200mAh Main COMMON 2.2(F), black, new fuse	BT.00307.006
	Battery SIMPLO UM-2008AW Li-Ion 3S1P SAMSUNG 3 cell 2200mAh Main COMMON 2.2 (F), white, new fuse (NEC)	BT.00307.007
	Battery PANASONIC UM-2008A Li-Ion 3S1P PANASONIC 3 cell 2900mAh Main COMMON	BT.00305.007
	Battery PANASONIC UM-2008AW Li-Ion 3S1P PANASONIC 3 cell 2900mAh Main COMMON white color	BT.00305.008
	Battery SANYO UM-2008B Li-Ion 3S2P SANYO 6 cell 4400mAh Main COMMON Black, 2.2Ah (A)	BT.00603.067
	Battery SANYO UM-2008BW Li-Ion 3S2P SANYO 6 cell 4400mAh Main COMMON White, 2.2 Ah (A)	BT.00603.068
	Battery SIMPLO UM-2008A Li-Ion 3S2P SAMSUNG 6 cell 4400mAh Main COMMON Macles	BT.00607.033
	Battery SIMPLO UM-2008BW Li-Ion 3S2P PANASONIC 6 cell 4400mAh Main COMMON White color, PSS CG type	BT.00607.039
	Battery SIMPLO UM-2008BW Li-Ion 3S2P SAMSUNG 6 cell 4400mAh Main COMMON white color, F type	BT.00607.040
	Battery SANYO UM-2008B Li-Ion 3S2P SANYO 6 cell 5200mAh Main COMMON Black	BT.00603.058
	Battery SANYO UM-2008BW Li-Ion 3S2P SANYO 6 cell 5200mAh Main COMMON white	BT.00603.059
	Battery SIMPLO UM-2008B Li-Ion 3S2P SAMSUNG 6 cell 5200mAh Main COMMON Macles Black	BT.00607.042
	Battery SIMPLO UM-2008B Li-Ion 3S2P LGC 6 cell 5200mAh Main COMMON Black, LGC 2.6 (B3)	BT.00607.055
	Battery SIMPLO UM-2008BW Li-Ion 3S2P LGC 6 cell 5200mAh Main COMMON White, LGC 2.6 (B3)	BT.00607.056
	Battery SIMPLO UM-2008BW Li-Ion 3S2P SAMSUNG 6 cell 5200mAh Main COMMON 2.6(C), white, new fuse (NEC)	BT.00607.058

Category	Description	Acer PN
	Battery PANASONIC UM-2008B Li-Ion 3S2P PANASONIC 6 cell 5800mAh Main COMMON Black, Macles	BT.00605.034
	Battery PANASONIC UM-2008BW Li-Ion 3S2P PANASONIC 6 cell 5800mAh Main COMMON white, Macles	BT.00605.035
Board		
	BLUE TOOTH BOARD	BT.21100.005
	USB BOARD	55.S5502.001
	POWER BOARD	55.S5502.002
	WLAN CARD-XB63	NI.23600.007
	3G CARD GTM382-Option	LC.21300.007
	3G CARD GTM380-Option	TBD
	3G CARD-Foxconn	TBD
Cable		
	BLUE TOOTH CABLE	50.S5502.001
	USB CABLE	50.S5502.002
	T/P FFC	50.S5502.004

Category	Description	Acer PN
Case/Cover/Bracket Assembly		
	UPPER CASE ASSY FOR W/BT F-BLACK	60.S5702.001
	UPPER CASE ASSY FOR W/O BT-BLACK	60.S5702.002
	UPPER CASE ASSY FOR W/BT F-RED	60.S5602.001
	UPPER CASE ASSY FOR W/O BT-RED	60.S5602.002
	UPPER CASE ASSY FOR W/BT F-GRAY	60.S5702.003
	UPPER CASE ASSY FOR W/O BT-GRAY	60.S5702.004
	UPPER CASE ASSY FOR W/BT F-BLUE	60.S6302.001
	UPPER CASE ASSY FOR W/O BT F-BLUE	60.S6302.002
	LOWER CASE ASSY FOR W/3G F-WHITE	60.S5502.001
	LOWER CASE ASSY FOR W/O 3G F-WHITE	60.S5502.002
	LOWER CASE ASSY FOR W/3G F-BLACK	60.S5702.005
	LOWER CASE ASSY FOR W/O 3G F-BLACK	60.S5702.006
	T/P BRACKET	33.S5502.001
	UP HINGE COVER R-BLACK	42.S5702.001
	UP HINGE COVER R-WHITE	42.S5502.001
	UP HINGE COVER L-BLACK	42.S5702.002
	UP HINGE COVER L-WHITE	42.S5502.002
	RAM DOOR-WHITE	42.S5502.003
	RAM DOOR-BLACK	42.S5702.003
	HDD DOOR-BLACK	42.S5702.004
	HDD DOOR-WHITE	42.S5502.004
	MINI PCI DOOR-BLACK	42.S5702.005
	MINI PCI DOOR-WHITE	42.S5502.005

Category	Description	Acer PN
HDD		
	Flash Disk SAMSUNG Flash Module NAND 16GB MMBRE16GSMPP-MVA LF	KF.16G0B.002
	HDD SEAGATE 2.5" 5400rpm 160GB ST9160310AS Crockett SATA LF F/W:0303	KH.16001.034
	HDD TOSHIBA 2.5" 5400rpm 160GB MK1652GSX Virgo BS SATA LF F/W:LV020J	KH.16004.004
	HDD TOSHIBA 2.5" 5400rpm 160GB MK1655GSX Libra SATA LF F/W: FG011J	KH.16004.006
	HDD HGST 2.5" 5400rpm 160GB HTS543216L9A300 Falcon-B SATA LF F/W:C40C	KH.16007.019
	HDD WD 2.5" 5400rpm 160GB WD1600BEVT-22ZCTO ML160 SATA LF F/W:11.01A11	KH.16008.022
	HDD SEAGATE 2.5" 5400rpm 250GB ST9250827AS Corsair SATA LF F/W:3.AAA	KH.25001.011
	HDD SEAGATE 2.5" 5400rpm 250GB ST9250315AS Wyatt SATA LF F/W:0001SDM1	KH.25001.016
	HDD HGST 2.5" 5400rpm 250GB HTS543225L9A300 Falcon-B SATA LF F/W:C40C	KH.25007.013
	HDD WD 2.5" 5400rpm 250GB WD2500BEVT-22ZCTO ML160 SATA LF F/W:11.01A11	KH.25008.021
	HDD CARRIER	33.S5502.002
Keyboard		
	KEYBOARD INTE(UI)-BLK	
	KEYBOARD (ARE) ARABIC ENGLISH-BLK	
	KEYBOARD (BE) BELGIAN-BLK	
	KEYBOARD (BZ) BRAZILIAN-BLK	
	KEYBOARD (CF) CANADIAN FRENCH-BLK	
	KEYBOARD (CH) T-CHINESE-BLK	
	KEYBOARD (CZ/SK) CZECH-SLOVAKIAN-BLK	
	KEYBOARD (DM) DENMARK-BLK	
	KEYBOARD (NL) NETHERLANDS-BLK	
	KEYBOARD (FR) FRENCH-BLK	
	KEYBOARD (GR) GERMAN-BLK	
	KEYBOARD (GK) GREEK-BLK	
	KEYBOARD (HG) HUNGARY-BLK	
	KEYBOARD (IT) ITALIAN-BLK	
	KEYBOARD (KO) KOREAN-BLK	
	KEYBOARD (NW) NORWEGIAN-BLK	
	KEYBOARD (PO) PORTUGUESE-BLK	
KEYBOARD (RU) RUSSIAN-BLK		
KEYBOARD (SA/CR) SLO/CRO-BLK		
KEYBOARD (SV) SLOVAK-BLK		

Category	Description	Acer PN
	KEYBOARD (SP) SPANISH-BLK	
	KEYBOARD (SD/FN) SWEDISH-BLK	
	KEYBOARD (SW) SWITZERLAND-BLK	
	KEYBOARD (TI) THAILAND-BLK	
	KEYBOARD (TR) TURKISH-BLK	
	KEYBOARD (UK)-BLK	
	KEYBOARD (HB) HEBREW-BLK	
	KEYBOARD (JP)-BLK	
	KEYBOARD (ND) SCANDINAVIAN-BLK	
	KEYBOARD (AR/FR) ARABIC/FRENCH-BLK	
	KEYBOARD (CB) CANADIAN BILINGUAL-BLK	
LCD		
	ASSY LED MODULE 10.1 IN. WXGA GLARE W/ ANTENNA CCD WHITE	6M.S5502.001
	LED LCD AUO 10.1" WSVGA Glare B101AW01 V0 LF 200nit 8ms 500:1	LK.10105.001
	LED LCD SAMSUNG 10.1" WSVGA Glare LTN101NT02- A01 LF 200nit 16ms 500:1	LK.10106.001
	LED LCD SAMSUNG 10.1" WSVGA Glare LTN101NT02- A01 LF 200nit 16ms 400:1	LK.10106.003
	LED LCD LPL 10.1" WSVGA Glare LP101WSA-TLA1 LF 200nit 16ms 400:1	LK.10108.001
	LED LCD CMO 10.1" WSVGA Glare N101L6-L02 LF 200nit 8ms 400:1	LK.1010D.001
	LCD COVER-WHITE-IMR	60.S5502.003
	ANTENNA WL-MAIN	50.S5502.005
	ANTENNA WL-AUX	50.S5502.006
	LCD BEZEL	60.S5502.004

Category	Description	Acer PN
	LCD CABLE	50.S5502.007
	LCD BRACKET-R&L	33.S5502.003
	CAMERA MODULE-0.3M	57.S5502.001
	CMOS CABLE	50.S5502.008
	ASSY LED MODULE 10.1 IN. WXGA GLARE W/ ANTENNA CCD BLACK	6M.S5702.001
	LED LCD AUO 10.1" WSVGA Glare B101AW01 V0 LF 200nit 8ms 500:1	LK.10105.001
	LED LCD SAMSUNG 10.1" WSVGA Glare LTN101NT02- A01 LF 200nit 16ms 500:1	LK.10106.001
	LED LCD SAMSUNG 10.1" WSVGA Glare LTN101NT02- A01 LF 200nit 16ms 400:1	LK.10106.003
	LED LCD LPL 10.1" WSVGA Glare LP101WSA-TLA1 LF 200nit 16ms 400:1	LK.10108.001
	LED LCD CMO 10.1" WSVGA Glare N101L6-L02 LF 200nit 8ms 400:1	LK.1010D.001
	LCD COVER-BLACK-IMR	60.S5702.007
	ANTENNA WL-MAIN	50.S5502.005
	ANTENNA WL-AUX	50.S5502.006
	LCD BEZEL	60.S5502.004

Category	Description	Acer PN
	LCD CABLE	50.S5502.007
	LCD BRACKET-R&L	33.S5502.003
	CAMERA MODULE-0.3M	57.S5502.001
	CMOS CABLE	50.S5502.008
	ASSY LED MODULE 10.1 IN. WXGA GLARE W/ ANTENNA CCD RED	6M.S5602.001
	LED LCD AUO 10.1" WSVGA Glare B101AW01 V0 LF 200nit 8ms 500:1	LK.10105.001
	LED LCD SAMSUNG 10.1" WSVGA Glare LTN101NT02- A01 LF 200nit 16ms 500:1	LK.10106.001
	LED LCD SAMSUNG 10.1" WSVGA Glare LTN101NT02- A01 LF 200nit 16ms 400:1	LK.10106.003
	LED LCD LPL 10.1" WSVGA Glare LP101WSA-TLA1 LF 200nit 16ms 400:1	LK.10108.001
	LED LCD CMO 10.1" WSVGA Glare N101L6-L02 LF 200nit 8ms 400:1	LK.1010D.001
	LCD COVER-RED-IMR	60.S5602.003
	ANTENNA WL-MAIN	50.S5502.005
	ANTENNA WL-AUX	50.S5502.006
	LCD BEZEL	60.S5502.004









Category	Description	Acer PN
	LCD CABLE	50.S5502.007
	LCD BRACKET-R&L	33.S5502.003
	CAMERA MODULE-0.3M	57.S5502.001
	CMOS CABLE	50.S5502.008
	ASSY LED MODULE 10.1 IN. WXGA GLARE W/ ANTENNA CCD BLUE	6M.S6202.001
	LED LCD AUO 10.1" WSVGA Glare B101AW01 V0 LF 200nit 8ms 500:1	LK.10105.001
	LED LCD SAMSUNG 10.1" WSVGA Glare LTN101NT02- A01 LF 200nit 16ms 500:1	LK.10106.001
	LED LCD SAMSUNG 10.1" WSVGA Glare LTN101NT02- A01 LF 200nit 16ms 400:1	LK.10106.003
	LED LCD LPL 10.1" WSVGA Glare LP101WSA-TLA1 LF 200nit 16ms 400:1	LK.10108.001
	LED LCD CMO 10.1" WSVGA Glare N101L6-L02 LF 200nit 8ms 400:1	LK.1010D.001
	LCD COVER-BLUE-IMR	60.S6302.003
	ANTENNA WL-MAIN	50.S5502.005
	ANTENNA WL-AUX	50.S5502.006
	LCD BEZEL	60.S5502.004

Category	Description	Acer PN
	LCD CABLE	50.S5502.007
	LCD BRACKET-R&L	33.S5502.003
	CAMERA MODULE-0.3M	57.S5502.001
	CMOS CABLE	50.S5502.008
	ASSY LED MODULE 10.1 IN. WXGA GLARE W/ ANTENNA CCD WHITE 3G	6M.S5802.001
	LED LCD AUO 10.1" WSVGA Glare B101AW01 V0 LF 200nit 8ms 500:1	LK.10105.001
	LED LCD SAMSUNG 10.1" WSVGA Glare LTN101NT02- A01 LF 200nit 16ms 500:1	LK.10106.001
	LED LCD SAMSUNG 10.1" WSVGA Glare LTN101NT02- A01 LF 200nit 16ms 400:1	LK.10106.003
	LED LCD LPL 10.1" WSVGA Glare LP101WSA-TLA1 LF 200nit 16ms 400:1	LK.10108.001
	LED LCD CMO 10.1" WSVGA Glare N101L6-L02 LF 200nit 8ms 400:1	LK.1010D.001
	LCD COVER-WHITE-IMR	60.S5502.003
	ANTENNA 3G-MAIN	50.S5802.001
	ANTENNA 3G-AUX	50.S5802.002
	ANTENNA 3G-WL/AUX	50.S5802.003
	LCD BEZEL	60.S5502.004

Category	Description	Acer PN
	LCD CABLE	50.S5502.007
	LCD BRACKET-R&L	33.S5502.003
	CAMERA MODULE-0.3M	57.S5502.001
	CMOS CABLE	50.S5502.008
	ASSY LED MODULE 10.1 IN. WXGA GLARE W/ ANTENNA CCD BLACK 3G	6M.S6102.001
	LED LCD AUO 10.1" WSVGA Glare B101AW01 V0 LF 200nit 8ms 500:1	LK.10105.001
	LED LCD SAMSUNG 10.1" WSVGA Glare LTN101NT02- A01 LF 200nit 16ms 500:1	LK.10106.001
	LED LCD SAMSUNG 10.1" WSVGA Glare LTN101NT02- A01 LF 200nit 16ms 400:1	LK.10106.003
	LED LCD LPL 10.1" WSVGA Glare LP101WSA-TLA1 LF 200nit 16ms 400:1	LK.10108.001
	LED LCD CMO 10.1" WSVGA Glare N101L6-L02 LF 200nit 8ms 400:1	LK.1010D.001
	LCD COVER-BLACK-IMR	60.S5702.007
	ANTENNA 3G-MAIN	50.S5802.001
	ANTENNA 3G-AUX	50.S5802.002
	ANTENNA 3G-WL/AUX	50.S5802.003
	LCD BEZEL	60.S5502.004

Category	Description	Acer PN
	LCD CABLE	50.S5502.007
	LCD BRACKET-R&L	33.S5502.003
	CAMERA MODULE-0.3M	57.S5502.001
	CMOS CABLE	50.S5502.008
	ASSY LED MODULE 10.1 IN. WXGA GLARE W/ ANTENNA CCD RED 3G	6M.S5902.001
	LED LCD AUO 10.1" WSVGA Glare B101AW01 V0 LF 200nit 8ms 500:1	LK.10105.001
	LED LCD SAMSUNG 10.1" WSVGA Glare LTN101NT02- A01 LF 200nit 16ms 500:1	LK.10106.001
	LED LCD SAMSUNG 10.1" WSVGA Glare LTN101NT02- A01 LF 200nit 16ms 400:1	LK.10106.003
	LED LCD LPL 10.1" WSVGA Glare LP101WSA-TLA1 LF 200nit 16ms 400:1	LK.10108.001
	LED LCD CMO 10.1" WSVGA Glare N101L6-L02 LF 200nit 8ms 400:1	LK.1010D.001
	LCD COVER-RED-IMR	60.S5602.003
	ANTENNA 3G-MAIN	50.S5802.001
	ANTENNA 3G-AUX	50.S5802.002
	ANTENNA 3G-WL/AUX	50.S5802.003
	LCD BEZEL	60.S5502.004

Category	Description	Acer PN
	LCD CABLE	50.S5502.007
	LCD BRACKET-R&L	33.S5502.003
	CAMERA MODULE-0.3M	57.S5502.001
	CMOS CABLE	50.S5502.008
	ASSY LED MODULE 10.1 IN. WXGA GLARE W/ ANTENNA CCD BLUE 3G	6M.S6302.001
	LED LCD AUO 10.1" WSVGA Glare B101AW01 V0 LF 200nit 8ms 500:1	LK.10105.001
	LED LCD SAMSUNG 10.1" WSVGA Glare LTN101NT02- A01 LF 200nit 16ms 500:1	LK.10106.001
	LED LCD SAMSUNG 10.1" WSVGA Glare LTN101NT02- A01 LF 200nit 16ms 400:1	LK.10106.003
	LED LCD LPL 10.1" WSVGA Glare LP101WSA-TLA1 LF 200nit 16ms 400:1	LK.10108.001
	LED LCD CMO 10.1" WSVGA Glare N101L6-L02 LF 200nit 8ms 400:1	LK.1010D.001
	LCD COVER-BLUE-IMR	60.S6302.003
	ANTENNA 3G-MAIN	50.S5802.001
	ANTENNA 3G-AUX	50.S5802.002
	ANTENNA 3G-WL/AUX	50.S5802.003
	LCD BEZEL	60.S5502.004

Category	Description	Acer PN
	LCD CABLE	50.S5502.007
	LCD BRACKET-R&L	33.S5502.003
	CAMERA MODULE-0.3M	57.S5502.001
	CMOS CABLE	50.S5502.008
Mainboard		
	MB ASSY 945GSE/ICH7M/ UMA FOR W/CPU W/O RAM FOR W/3G F	MB.S6102.001
	MB ASSY 945GSE/ICH7M/ UMA FOR W/CPU W/O RAM FOR W/O 3G F	MB.S5702.001
Memory		
	Memory NANYA SO-DIMM DDRII 667 1GB NT1GT64UH8D0FN-3C LF 64*16 0.07um	KN.1GB03.026
	Memory SAMSUNG SO-DIMM DDRII 667 1GB M470T2864EH3-CE6 LF 64*16 0.055um	KN.1GB0B.027
	Memory HYNIX SO-DIMM DDRII 667 1GB HMP112S6EFR6C-Y5 LF 64*16 0.055um	KN.1GB0G.022
	Memory NANYA SO-DIMM DDRII 667 2GB NT2GT64U8HD0BN-3C LF 128*8 0.07um	KN.2GB03.011
	Memory SAMSUNG SO-DIMM DDRII 667 2GB M470T5663EH3-CE6 LF 128*8 0.055um	KN.2GB0B.011
	Memory HYNIX SO-DIMM DDRII 667 2GB HMP125S6EFR8C-Y5 LF 128*8 0.055um	KN.2GB0G.012
	Memory SAMSUNG SO-DIMM DDRII 667 512MB M470T6464QZ3-CE6 LF	KN.5120B.026
	Memory HYNIX SO-DIMM DDRII 667 512MB HYMP164S64CP6-Y5 LF 64*16 0.065um	KN.5120G.024
Heat sink		
	CPU THERMAL MODULE	60.S5502.005
Speaker		
	MIC SET	23.S5502.001

Category	Description	Acer PN
	SPEAKER-R&L	23.S5502.002
Miscellaneous		
	NAME PLATE FOR W/BT MYLAR	
	NAME PLATE FOR W/O BT MYLAR	
	NAME PLATE FOR W/WL MYLAR	40.S5502.001
	NAME PLATE FOR W/ 3G+WL MYLAR	40.S5802.001
	NAME PLATE FOR W/CMOS MYLAR	
	NAME PLATE FOR HINGE CAP MYLAR R-GREEN	40.S5502.002
	NAME PLATE FOR HINGE CAP MYLAR L-GREEN	40.S5502.003
	KAV10 NAME PLATE-HINGE CAP MYLAR-R-RED	40.S5602.001
	KAV10 NAME PLATE-HINGE CAP MYLAR-L-RED	40.S5602.002
	KAV10 NAME PLATE-HINGE CAP MYLAR-R-BLK	40.S5702.001
	KAV10 NAME PLATE-HINGE CAP MYLAR-L-BLK	40.S5702.002
	KAV10 NAME PLATE-HINGE CAP MYLAR-R-BLUE	40.S6202.001
	KAV10 NAME PLATE-HINGE CA	
	AP MYLAR-L-BLUE	40.S6202.002
	SCREW PAD	47.S5502.001

Screw List

Category	Description	Acer P/N
SCREW	SCREW M1.98D 3.0L K4.6D 0.8T ZK	86.S5502.001
SCREW	SCREW M2D 6L K4.6D ZK NL + CR3	86.S5502.002
SCREW	SCREW M3.0D 3.0L K 4.9D(NI)	86.S5502.003

Model Definition and Configuration

Aspire one Series

Model	RO	Country	Acer P/N	Description	CPU
AOD150-0Bb	PA	ACLA-Spanish	LU.S620B.089	AOD150-0Bb EM AOXPSTEA1 MC UMACb 1*1G/160/3L/5R/ CB_bg_0.3D_GEb_ES21	ATMN270B
AOD150-0Bb	PA	ACLA-Spanish	LU.S620B.085	AOD150-0Bb EM AOXPSTEA1 MC UMACb 1*1G/160/3L/5R/ CB_bg_0.3D_BAG_GEb_ES21	ATMN270B
AOD150-1Bb	AAP	Thailand	LU.S620B.088	AOD150-1Bb AOXPSTTH1 MC UMACb 1*1G/160/BT/3L/5R/ CB_bg_0.3D_BAG_GEb_TH22	ATMN280B
AOD150-0Bb	AAP	Japan	LU.S620B.026	AOD150-0Bb AOXPSTJP1 MC UMACb 1*1G/160/BT/3L/5R/ CB_bg_0.3D_BAG_GEb_JA11_Bb7_3_IMR	ATMN270B
AOD150-1Bb	EMEA	Denmark	LU.S620B.087	AOD150-1Bb AOXPSTDK2 MC UMACb 1*1G/160/BT/6L/5R/ CB_bg_0.3D_GEb_ENS1	ATMN280B
AOD150-0Bb	PA	ACLA-Portuguese	LU.S620B.086	AOD150-0Bb EM AOXPSTXC2 MC UMACb 1*1G/160/3L/5R/ CB_bg_0.3D_GEb_XC21	ATMN270B
AOD150-0Bb	PA	ACLA-Portuguese	LU.S620B.083	AOD150-0Bb EM AOXPSTXC2 MC UMACb 1*1G/160/6L2.6/5R/ CB_bg_0.3D_BAG_GEb_XC21	ATMN270B
AOD150-0Bb	PA	ACLA-Spanish	LU.S620B.084	AOD150-0Bb EM AOXPSTEA3 MC UMACb 1*1G/160/3L/5R/ CB_bg_0.3D_GEb_ES21	ATMN270B
AOD150-0Bb	PA	ACLA-Spanish	LU.S620B.082	AOD150-0Bb EM AOXPSTEA1 MC UMACb 1*1G/160/6L2.6/5R/ CB_bg_0.3D_BAG_GEb_ES21	ATMN270B
AOD150-0Bb	PA	ACLA-Spanish	LU.S620B.081	AOD150-0Bb EM AOXPSTEA3 MC UMACb 1*1G/160/6L2.6/5R/ CB_bg_0.3D_BAG_GEb_ES21	ATMN270B
AOD150-1Bb	EMEA	South Africa	LU.S620B.079	AOD150-1Bb EM AOXPSTZA1 MC UMACb 1*1G/160/3L/5R/ CB_bg_0.3D_GEb_FR22	ATMN280B
AOD150-1Bb	EMEA	South Africa	LU.S620B.080	AOD150-1Bb EM AOXPSTZA2 MC UMACb 1*1G/160/3L/5R/ CB_bg_0.3D_GEb_EN12	ATMN280B
AOD150-1Bb	EMEA	Germany	LU.S620B.074	AOD150-1Bb AOXPSTDE1 MC UMACb 1*1G/160/3L/5R/ CB_bg_0.3D_GEb_DE51	ATMN280B
AOD150-1Bb	EMEA	Germany	LU.S620B.075	AOD150-1Bb AOXPSTDE1 MC UMACb 1*1G/160/3L/5R/ CB_bg_0.3D_GEb_DE12	ATMN280B
AOD150-1Bb	EMEA	Denmark	LU.S620B.077	AOD150-1Bb AOXPSTDK2 MC UMACb 1*1G/160/3L/5R/ CB_bg_0.3D_GEb_ENS1	ATMN280B

Model	RO	Country	Acer P/N	Description	CPU
AOD150-1Bb	EMEA	Belgium	LU.S620B.073	AOD150-1Bb AOXPSTBE1 MC UMACb 1*1G/160/3L/5R/ CB_bg_0.3D_GEb_NL12	ATMN280B
AOD150-1Bb	EMEA	Denmark	LU.S620B.076	AOD150-1Bb AOXPSTDK1 MC UMACb 1*1G/160/3L/5R/ CB_bg_0.3D_GEb_NO12	ATMN280B
AOD150-1Bb	EMEA	France	LU.S620B.078	AOD150-1Bb AOXPSTFR1 MC UMACb 1*1G/160/3L/5R/ CB_bg_0.3D_GEb_FR22	ATMN280B
AOD150-1Bb	EMEA	Eastern Europe	LU.S620B.068	AOD150-1Bb AOXPSTEU7 MC UMACb 1*1G/160/3L/5R/ CB_bg_0.3D_GEb_EN11	ATMN280B
AOD150-1Bb	EMEA	Luxembourg	LU.S620B.070	AOD150-1Bb AOXPSTLU3 MC UMACb 1*1G/160/3L/5R/ CB_bg_0.3D_GEb_IT41	ATMN280B
AOD150-1Bb	EMEA	Austria	LU.S620B.066	AOD150-1Bb AOXPSTAT1 MC UMACb 1*1G/160/3L/5R/ CB_bg_0.3D_GEb_DE11	ATMN280B
AOD150-1Bb	EMEA	Eastern Europe	LU.S620B.064	AOD150-1Bb AOXPSTEU5 MC UMACb 1*1G/160/3L/5R/ CB_bg_0.3D_GEb_PL14	ATMN280B
AOD150-1Bb	EMEA	Holland	LU.S620B.069	AOD150-1Bb AOXPSTNL1 MC UMACb 1*1G/160/3L/5R/ CB_bg_0.3D_GEb_NL12	ATMN280B
AOD150-1Bb	EMEA	Norway	LU.S620B.071	AOD150-1Bb AOXPSTNO1 MC UMACb 1*1G/160/3L/5R/ CB_bg_0.3D_GEb_NO12	ATMN280B
AOD150-1Bb	EMEA	Eastern Europe	LU.S620B.065	AOD150-1Bb AOXPSTEU3 MC UMACb 1*1G/160/3L/5R/ CB_bg_0.3D_GEb_RU24	ATMN280B
AOD150-1Bb	EMEA	Russia	LU.S620B.072	AOD150-1Bb AOXPSTRU1 MC UMACb 1*1G/160/3L/5R/ CB_bg_0.3D_GEb_RU12	ATMN280B
AOD150-1Bb	EMEA	Sweden	LU.S620B.067	AOD150-1Bb AOXPSTSE1 MC UMACb 1*1G/160/3L/5R/ CB_bg_0.3D_GEb_FI13	ATMN280B
AOD150-1Bb	EMEA	Eastern Europe	LU.S620B.063	AOD150-1Bb AOXPSTEU7 MC UMACb 1*1G/160/3L/5R/ CB_bg_0.3D_GEb_ENR2	ATMN280B
AOD150-1Bb	EMEA	Portugal	LU.S620B.055	AOD150-1Bb AOXPSTPT1 MC UMACb 1*1G/160/3L/5R/ CB_bg_0.3D_GEb_PT12	ATMN280B
AOD150-1Bb	EMEA	Greece	LU.S620B.053	AOD150-1Bb AOXPSTGR1 MC UMACb 1*1G/160/3L/5R/ CB_bg_0.3D_GEb_EL32	ATMN280B
AOD150-1Bb	EMEA	Spain	LU.S620B.054	AOD150-1Bb AOXPSTES1 MC UMACb 1*1G/160/3L/5R/ CB_bg_0.3D_GEb_ES22	ATMN280B
AOD150-1Bb	EMEA	Eastern Europe	LU.S620B.059	AOD150-1Bb AOXPSTEU5 MC UMACb 1*1G/160/3L/5R/ CB_bg_0.3D_GEb_RO12	ATMN280B
AOD150-1Bb	EMEA	Finland	LU.S620B.062	AOD150-1Bb AOXPSTFI2 MC UMACb 1*1G/160/3L/5R/ CB_bg_0.3D_GEb_FI11	ATMN280B
AOD150-1Bb	EMEA	Finland	LU.S620B.057	AOD150-1Bb AOXPSTFI2 MC UMACb 1*1G/160/3L/5R/ CB_bg_0.3D_GEb_FI41	ATMN280B

Model	RO	Country	Acer P/N	Description	CPU
AOD150-1Bb	EMEA	Finland	LU.S620B.058	AOD150-1Bb AOXPSTFI2 MC UMACb 1*1G/160/3L/5R/ CB_bg_0.3D_GEb_SV41	ATMN280B
AOD150-1Bb	EMEA	Finland	LU.S620B.056	AOD150-1Bb AOXPSTFI2 MC UMACb 1*1G/160/3L/5R/ CB_bg_0.3D_GEb_FI31	ATMN280B
AOD150-1Bb	EMEA	Eastern Europe	LU.S620B.060	AOD150-1Bb AOXPSTEU4 MC UMACb 1*1G/160/3L/5R/ CB_bg_0.3D_GEb_FI13	ATMN280B
AOD150-1Bb	EMEA	Eastern Europe	LU.S620B.061	AOD150-1Bb AOXPSTEU7 MC UMACb 1*1G/160/3L/5R/ CB_bg_0.3D_GEb_SL11	ATMN280B
AOD150-1Bb	EMEA	Middle East	LU.S620B.047	AOD150-1Bb EM AOXPSTME3 MC UMACb 1*1G/160/3L/5R/ CB_bg_0.3D_GEb_FR22	ATMN280B
AOD150-1Bb	EMEA	Hungary	LU.S620B.052	AOD150-1Bb AOXPSTHU1 MC UMACb 1*1G/160/3L/5R/ CB_bg_0.3D_GEb_HU14	ATMN280B
AOD150-1Bb	EMEA	Israel	LU.S620B.049	AOD150-1Bb AOXPSTIL1 MC UMACb 1*1G/160/3L/5R/ CB_bg_0.3D_GEb_HE13	ATMN280B
AOD150-1Bb	EMEA	Middle East	LU.S620B.046	AOD150-1Bb EM AOXPSTME4 MC UMACb 1*1G/160/3L/5R/ CB_bg_0.3D_GEb_EN12	ATMN280B
AOD150-1Bb	EMEA	Middle East	LU.S620B.048	AOD150-1Bb EM AOXPSTME2 MC UMACb 1*1G/160/3L/5R/ CB_bg_0.3D_GEb_AR22	ATMN280B
AOD150-1Bb	EMEA	Italy	LU.S620B.051	AOD150-1Bb AOXPSTIT1 MC UMACb 1*1G/160/3L/5R/ CB_bg_0.3D_GEb_IT51	ATMN280B
AOD150-1Bb	EMEA	Italy	LU.S620B.050	AOD150-1Bb AOXPSTIT1 MC UMACb 1*1G/160/3L/5R/ CB_bg_0.3D_GEb_IT12	ATMN280B
AOD150-1Bb	EMEA	Middle East	LU.S620B.042	AOD150-1Bb EM AOXPSTME2 MC UMACb 1*1G/160/3L/5R/ CB_bg_0.3D_GEb_AR12	ATMN280B
AOD150-1Bb	EMEA	UK	LU.S620B.036	AOD150-1Bb AOXPSTGB1 MC UMACb 1*1G/160/3L/5R/ CB_bg_0.3D_GEb_EN12	ATMN280B
AOD150-1Bb	EMEA	Switzerland	LU.S620B.038	AOD150-1Bb AOXPSTCH1 MC UMACb 1*1G/160/3L/5R/ CB_bg_0.3D_GEb_IT81	ATMN280B
AOD150-1Bb	EMEA	Turkey	LU.S620B.041	AOD150-1Bb AOXPSTTR1 MC UMACb 1*1G/160/3L/5R/ CB_bg_0.3D_GEb_TR33	ATMN280B
AOD150-1Bb	EMEA	Middle East	LU.S620B.044	AOD150-1Bb EM AOXPSTME9 MC UMACb 1*1G/160/3L/5R/ CB_bg_0.3D_GEb_FR22	ATMN280B
AOD150-1Bb	EMEA	Switzerland	LU.S620B.039	AOD150-1Bb AOXPSTCH1 MC UMACb 1*1G/160/3L/5R/ CB_bg_0.3D_GEb_IT42	ATMN280B
AOD150-1Bb	EMEA	Ukraine	LU.S620B.037	AOD150-1Bb AOXPSTUK1 MC UMACb 1*1G/160/3L/5R/ CB_bg_0.3D_GEb_RU11	ATMN280B
AOD150-1Bb	EMEA	Middle East	LU.S620B.043	AOD150-1Bb EM AOXPSTME6 MC UMACb 1*1G/160/3L/5R/ CB_bg_0.3D_GEb_EN12	ATMN280B

Model	RO	Country	Acer P/N	Description	CPU
AOD150-1Bb	EMEA	Poland	LU.S620B.040	AOD150-1Bb AOXPSTPL1 MC UMACb 1*1G/160/3L/5R/ CB_bg_0.3D_GEb_PL11	ATMN280B
AOD150-1Bb	EMEA	Middle East	LU.S620B.045	AOD150-1Bb EM AOXPSTME2 MC UMACb 1*1G/160/3L/5R/ CB_bg_0.3D_GEb_EN12	ATMN280B
AOD150-1Bb	AAP	Philippines	LU.S620B.027	AOD150-1Bb AOXPSTPH1 MC UMACb 1*1G/160/BT/6L2.6/5R/ CB_bg_0.3D_BAG_GEb_EN12	ATMN280B
AOD150-0Bb	AAP	Japan	LU.S620B.034	AOD150-0Bb AOXPSTJP1 MC UMACb 1*1G/160/BT/3L/5R/ CB_bg_0.3D_BAG_GEb_JA11_Bb7 3_UV	ATMN270B
AOD150-1Bb	AAP	Indonesia	LU.S620B.033	AOD150-1Bb EM AOXPSTID1 MC UMACb 1*1G/160/BT/6L/5R/ CB_bg_0.3D_BAG_GEb_ID22	ATMN280B
AOD150-0Bb	AAP	Japan	LU.S620B.035	AOD150-0Bb AOXPSTJP1 MC UMACb 1*1G/160/BT/6L2.6/5R/ CB_bg_0.3D_BAG_GEb_JA11_Bb7 6_UV	ATMN270B
AOD150-0Bb	AAP	Japan	LU.S620B.025	AOD150-0Bb AOXPSTJP1 MC UMACb 1*1G/160/BT/6L2.6/5R/ CB_bg_0.3D_BAG_GEb_JA11_Bb7 6_IMR	ATMN270B
AOD150-1Bb	TWN	GCTWN	LU.S620B.005	AOD150-1Bb AOXPSTTW1 MC UMACb 1*1G/160/BT/6L2.6/5R/ CB_bg_0.3D_BAG_GEb_TC11	ATMN280B
AOD150-0Bb	TWN	GCTWN	LU.S620B.007	AOD150-0Bb AOXPSTTW1 MC UMACb 1*1G/160/BT/6L2.6/5R/ CB_bg_0.3D_BAG_GEb_TC11	ATMN270B
AOD150-0Bb	CHINA	China	LU.S620B.002	AOD150-0Bb AOXPSTCN1 MC UMACb 1*1G/160/6L2.6/5R/ CB_bg_0.3D_BAG_GEb_SC11	ATMN270B
AOD150-0Bb	CHINA	Hong Kong	LU.S620B.001	AOD150-0Bb AOXPSTHK2 MC UMACb 1*1G/160/BT/6L2.6/5R/ CB_bg_0.3D_BAG_GEb_ZH31	ATMN270B
AOD150-1Bb	AAP	Philippines	LU.S620B.024	AOD150-1Bb AOXPSTPH1 MC UMACb 1*1G/160/BT/3L/5R/ CB_bg_0.3D_BAG_GEb_EN12	ATMN280B
AOD150-0Bb	AAP	Japan	LU.S620B.031	AOD150-0Bb AOXPSTJP1 MC UMACb 1*1G/160/BT/6L/5R/ CB_bg_0.3D_BAG_GEb_JA11	ATMN270B
AOD150-1Bb	AAP	Japan	LU.S620B.029	AOD150-1Bb AOXPSTJP1 MC UMACb 1*1G/160/BT/6L/5R/ CB_bg_0.3D_BAG_GEb_JA11	ATMN280B
AOD150-1Bb	AAP	Singapore	LU.S620B.030	AOD150-1Bb AOXPSTSG1 MC UMACb 1*1G/160/BT/6L/5R/ CB_bg_0.3D_BAG_GEb_EN11	ATMN280B
AOD150-0Bb	AAP	Singapore	LU.S620B.028	AOD150-0Bb AOXPSTSG1 MC UMACb 1*1G/160/BT/6L/5R/ CB_bg_0.3D_BAG_GEb_EN11	ATMN270B
AOD150-0Bb	AAP	Australia/ New Zealand	LU.S620B.032	AOD150-0Bb AOXPSTAU1 MC UMACb 1*1G/160/BT/6L/5R/ CB_bg_0.3D_BAG_GEb_EN11	ATMN270B
AOD150-0Bb	PA	Canada	LU.S620B.014	AOD150-0Bb AOXPSTCA2 MC UMACb 1*1G/160/6L/5R/ CB_bg_0.3D_GEb_FR31	ATMN270B

Model	RO	Country	Acer P/N	Description	CPU
AOD150-0Bb	PA	USA	LU.S620B.011	AOD150-0Bb AOXPSTUS1 MC UMACb 1*1G/160/6L/5R/ CB_bg_0.3D_GEb_EN31	ATMN270B
AOD150-0Bb	CHINA	Hong Kong	LU.S620B.023	AOD150-0Bb AOXPSTHK2 MC UMACb 1*1G/160/3L/5R/ CB_bg_0.3D_BAG_GEb_ZH31	ATMN270B
AOD150-1Bb	CHINA	Hong Kong	LU.S620B.021	AOD150-1Bb AOXPSTHK2 MC UMACb 1*1G/160/3L/5R/ CB_bg_0.3D_BAG_GEb_ZH31	ATMN280B
AOD150-1Bb	CHINA	China	LU.S620B.022	AOD150-1Bb AOXPSTCN1 MC UMACb 1*1G/160/3L/5R/ CB_bg_0.3D_BAG_GEb_SC11	ATMN280B
AOD150-0Bb	PA	Canada	LU.S620B.020	AOD150-0Bb AOXPSTCA2 MC UMACb 1*1G/160/3L/5R/ CB_bg_0.3D_GEb_FR34	ATMN270B
AOD150-0Bb	PA	Canada	LU.S620B.019	AOD150-0Bb AOXPSTCA2 MC UMACb 1*1G/160/3L/5R/ CB_bg_0.3D_GEb_FR33	ATMN270B
AOD150-0Bb	PA	USA	LU.S620B.018	AOD150-0Bb AOXPSTUS1 MC UMACb 1*1G/160/3L/5R/ CB_bg_0.3D_GEb_EN31	ATMN270B
AOD150-0Bb	PA	Canada	LU.S620B.013	AOD150-0Bb AOXPSTCA2 MC UMACb 1*1G/160/6L/5R/ CB_bg_0.3D_GEb_FR34	ATMN270B
AOD150-0Bb	PA	Canada	LU.S620B.015	AOD150-0Bb AOXPSTCA2 MC UMACb 1*1G/160/3L/5R/ CB_bg_0.3D_GEb_FR31	ATMN270B
AOD150-0Bb	PA	USA	LU.S620B.016	AOD150-0Bb AOXPSTUS1 MC UMACb 1*1G/160/3L/5R/ CB_bg_0.3D_GEb_EN35	ATMN270B
AOD150-0Bb	PA	USA	LU.S620B.017	AOD150-0Bb AOXPSTUS1 MC UMACb 1*1G/160/3L/5R/ CB_bg_0.3D_GEb_EN33	ATMN270B
AOD150-0Bb	PA	Canada	LU.S620B.012	AOD150-0Bb AOXPSTCA2 MC UMACb 1*1G/160/6L/5R/ CB_bg_0.3D_GEb_FR33	ATMN270B
AOD150-0Bb	PA	USA	LU.S620B.010	AOD150-0Bb AOXPSTUS1 MC UMACb 1*1G/160/6L/5R/ CB_bg_0.3D_GEb_EN33	ATMN270B
AOD150-1Bb	TWN	GCTWN	LU.S620B.006	AOD150-1Bb AOXPSTTW1 MC UMACb 1*1G/160/BT/3L/5R/ CB_bg_0.3D_BAG_GEb_TC11	ATMN280B
AOD150-0Bb	TWN	GCTWN	LU.S620B.008	AOD150-0Bb AOXPSTTW1 MC UMACb 1*1G/160/BT/3L/5R/ CB_bg_0.3D_BAG_GEb_TC11	ATMN270B
AOD150-0Bb	PA	USA	LU.S620B.009	AOD150-0Bb AOXPSTUS1 MC UMACb 1*1G/160/6L/5R/ CB_bg_0.3D_GEb_EN35	ATMN270B
AOD150-0Bb	CHINA	China	LU.S620B.004	AOD150-0Bb AOXPSTCN1 MC UMACb 1*1G/160/3L/5R/ CB_bg_0.3D_BAG_GEb_SC11	ATMN270B
AOD150-0Bb	CHINA	Hong Kong	LU.S620B.003	AOD150-0Bb AOXPSTHK2 MC UMACb 1*1G/160/BT/3L/5R/ CB_bg_0.3D_BAG_GEb_ZH31	ATMN270B
AOD150-1Bk	EMEA	Holland	LU.S570B.067	AOD150-1Bk AOXPSTNL1 MC UMACk 1*1G/160/BT/6L/5R/ CB_bg_0.3D_GEk_NL12	ATMN280B

Model	RO	Country	Acer P/N	Description	CPU
AOD150-1Bk	EMEA	Middle East	LU.S570B.039	AOD150-1Bk EM AOXPSTME2 MC UMACK 1*1G/160/BT/6L/5R/ CB_bg_0.3D_GEk_AR22	ATMN280B
AOD150-0Bk	EMEA	France	LU.S570B.177	AOD150-0Bk AOXPSTFR1 MC UMACK 1*1G/160/BT/3L/5R/ CB_bg_0.3D_GEk_FR22	ATMN270B
AOD150-1Bk	EMEA	Norway	LU.S570B.062	AOD150-1Bk AOXPSTNO1 MC UMACK 1*1G/160/BT/6L/5R/ CB_bg_0.3D_GEk_NO12	ATMN280B
AOD150-0Bk	PA	USA	LU.S570B.146	AOD150-0Bk AOXPSTUS1 MC UMACK 1*1G/160/6L/5R/ CB_bg_0.3D_GEk_EN31	ATMN270B
AOD150-0Bk	AAP	Japan	LU.S570B.011	AOD150-0Bk AOXPSTJP1 MC UMACK 1*1G/160/BT/3L/5R/ CB_bg_0.3D_BAG_GEk_JA11_bk73	ATMN270B
AOD150-1Bk	EMEA	Denmark	LU.S570B.176	AOD150-1Bk AOXPSTDK2 MC UMACK 1*1G/160/3L/5R/ CB_bg_0.3D_GEk_ENS1	ATMN280B
AOD150-1Bk	EMEA	Denmark	LU.S570B.175	AOD150-1Bk AOXPSTDK2 MC UMACK 1*1G/160/BT/6L/5R/ CB_bg_0.3D_GEk_ENS1	ATMN280B
AOD150-0Bk	EMEA	France	LU.S570B.174	AOD150-0Bk AOXPSTFR1 MC UMACK 1*1G/160/BT/3L/5R/ CB_bg_0.3D_BAG_GEk_FR22	ATMN270B
AOD150-1Bk	EMEA	South Africa	LU.S570B.173	AOD150-1Bk EM AOXPSTZA1 MC UMACK 1*1G/160/3L/5R/ CB_bg_0.3D_BAG_GEk_FR22	ATMN280B
AOD150-1Bk	EMEA	South Africa	LU.S570B.172	AOD150-1Bk EM AOXPSTZA2 MC UMACK 1*1G/160/3L/5R/ CB_bg_0.3D_BAG_GEk_EN12	ATMN280B
AOD150-1Bk	EMEA	Denmark	LU.S570B.171	AOD150-1Bk AOXPSTDK1 MC UMACK 1*1G/160/3L/5R/ CB_bg_0.3D_BAG_GEk_NO12	ATMN280B
AOD150-1Bk	EMEA	Denmark	LU.S570B.168	AOD150-1Bk AOXPSTDK2 MC UMACK 1*1G/160/3L/5R/ CB_bg_0.3D_BAG_GEk_ENS1	ATMN280B
AOD150-1Bk	EMEA	France	LU.S570B.169	AOD150-1Bk AOXPSTFR1 MC UMACK 1*1G/160/3L/5R/ CB_bg_0.3D_BAG_GEk_FR22	ATMN280B
AOD150-1Bk	EMEA	Norway	LU.S570B.164	AOD150-1Bk AOXPSTNO1 MC UMACK 1*1G/160/3L/5R/ CB_bg_0.3D_BAG_GEk_NO12	ATMN280B
AOD150-1Bk	EMEA	Belgium	LU.S570B.165	AOD150-1Bk AOXPSTBE1 MC UMACK 1*1G/160/3L/5R/ CB_bg_0.3D_BAG_GEk_NL12	ATMN280B
AOD150-1Bk	EMEA	Germany	LU.S570B.170	AOD150-1Bk AOXPSTDE1 MC UMACK 1*1G/160/3L/5R/ CB_bg_0.3D_BAG_GEk_DE12	ATMN280B
AOD150-1Bk	EMEA	Luxembourg	LU.S570B.167	AOD150-1Bk AOXPSTLU3 MC UMACK 1*1G/160/3L/5R/ CB_bg_0.3D_BAG_GEk_IT41	ATMN280B
AOD150-1Bk	EMEA	Holland	LU.S570B.166	AOD150-1Bk AOXPSTNL1 MC UMACK 1*1G/160/3L/5R/ CB_bg_0.3D_BAG_GEk_NL12	ATMN280B

Model	RO	Country	Acer P/N	Description	CPU
AOD150-1Bk	EMEA	UK	LU.S570B.163	AOD150-1Bk AOXPSTGB1 MC UMACK 1*1G/160/3L/5R/ CB_bg_0.3D_BAG_GEk_EN12	ATMN280B
AOD150-0Bk	PA	ACLA-Spanish	LU.S570B.161	AOD150-0Bk EM AOXPSTEA1 MC UMACK 1*1G/160/3L/5R/ CB_bg_0.3D_BAG_GEk_ES21	ATMN270B
AOD150-0Bk	PA	ACLA-Portuguese	LU.S570B.162	AOD150-0Bk EM AOXPSTXC2 MC UMACK 1*1G/160/3L/5R/ CB_bg_0.3D_BAG_GEk_XC21	ATMN270B
AOD150-0Bk	PA	ACLA-Spanish	LU.S570B.158	AOD150-0Bk EM AOXPSTEA1 MC UMACK 1*1G/160/6L2.6/5R/ CB_bg_0.3D_BAG_GEk_ES21	ATMN270B
AOD150-0Bk	PA	ACLA-Spanish	LU.S570B.157	AOD150-0Bk EM AOXPSTEA3 MC UMACK 1*1G/160/6L2.6/5R/ CB_bg_0.3D_BAG_GEk_ES21	ATMN270B
AOD150-0Bk	PA	ACLA-Spanish	LU.S570B.160	AOD150-0Bk EM AOXPSTEA3 MC UMACK 1*1G/160/3L/5R/ CB_bg_0.3D_BAG_GEk_ES21	ATMN270B
AOD150-0Bk	PA	ACLA-Portuguese	LU.S570B.159	AOD150-0Bk EM AOXPSTXC2 MC UMACK 1*1G/160/6L2.6/5R/ CB_bg_0.3D_BAG_GEk_XC21	ATMN270B
AOD150-0Bk	AAP	Japan	LU.S570B.010	AOD150-0Bk AOXPSTJP1 MC UMACK 1*1G/160/BT/6L2.6/5R/ CB_bg_0.3D_BAG_GEk_JA11_Bk76	ATMN270B
AOD150-0Bk	AAP	Japan	LU.S570B.019	AOD150-0Bk AOXPSTJP1 MC UMACK 1*1G/160/BT/6L2.6/5R/ CB_bg_0.3D_BAG_GEk_JA11_Bk76f	ATMN270B
AOD150-1Bk	AAP	Japan	LU.S570B.026	AOD150-1Bk AOXPSTJP1 MC UMACK 1*1G/160/BT/6L2.6/5R/ CB_bg_0.3D_BAG_GEk_JA11_Bk86	ATMN280B
AOD150-0Bk	AAP	Indonesia	LU.S570B.153	AOD150-0Bk AOXPSTID1 MC UMACK 1*1G/160/BT/6L2.6/5R/ CB_bg_0.3D_BAG_GEk_ID23	ATMN270B
AOD150-0Bk	TWN	GCTWN	LU.S570B.005	AOD150-0Bk AOXPSTTW1 MC UMACK 1*1G/160/BT/6L2.6/ CB_bg_0.3D_BAG_GEk_TC11	ATMN270B
AOD150-1Bk	AAP	Philippines	LU.S570B.154	AOD150-1Bk AOXPSTPH1 MC UMACK 1*1G/160/BT/6L2.6/5R/ CB_bg_0.3D_BAG_GEk_EN12	ATMN280B
AOD150-0Bk	AAP	Philippines	LU.S570B.013	AOD150-0Bk AOXPSTPH1 MC UMACK 1*1G/160/6L2.6/5R/ CB_bg_0.3D_BAG_GEk_EN12	ATMN270B
AOD150-1Bk	AAP	Japan	LU.S570B.024	AOD150-1Bk AOXPSTJP1 MC UMACK 1*1G/160/BT/6L2.6/5R/ CB_bg_0.3D_BAG_GEk_JA11_Bk86f	ATMN280B
AOD150-0Bk	CHINA	China	LU.S570B.009	AOD150-0Bk AOXPSTCN1 MC UMACK 1*1G/160/BT/6L2.6/ CB_bg_0.3D_BAG_GEk_SC11	ATMN270B
AOD150-0Bk	CHINA	Hong Kong	LU.S570B.008	AOD150-0Bk AOXPSTHK2 MC UMACK 1*1G/160/BT/6L2.6/ CB_bg_0.3D_BAG_GEk_ZH31	ATMN270B
AOD150-1Bk	AAP	Vietnam	LU.S570B.022	AOD150-1Bk AOXPSTVN1 MC UMACK 1*1G/160/BT/3L/5R/ CB_bg_0.3D_BAG_GEk_EN12	ATMN280B

Model	RO	Country	Acer P/N	Description	CPU
AOD150-0Bk	AAP	Vietnam	LU.S570B.021	AOD150-0Bk AOXPSTVN1 MC UMACK 1*1G/160/3L/5R/ CB_bg_0.3D_BAG_GEk_EN12	ATMN270B
AOD150-1Bk	AAP	Thailand	LU.S570B.029	AOD150-1Bk AOXPSTTH1 MC UMACK 1*1G/160/BT/3L/5R/ CB_bg_0.3D_BAG_GEk_TH22	ATMN280B
AOD150-1Bk	AAP	Thailand	LU.S570B.028	AOD150-1Bk AOXPSTTH1 MC UMACK 1*1G/160/3L/5R/ CB_bg_0.3D_BAG_GEk_TH22	ATMN280B
AOD150-0Bk	AAP	Malaysia	LU.S570B.151	AOD150-0Bk AOXPSTMY1 MC UMACK 1*1G/160/BT/6L/5R/ CB_bg_0.3D_BAG_GEk_EN12	ATMN270B
AOD150-1Bk	AAP	Malaysia	LU.S570B.023	AOD150-1Bk AOXPSTMY1 MC UMACK 1*1G/160/BT/6L/5R/ CB_bg_0.3D_BAG_GEk_EN12	ATMN280B
AOD150-1Bk	AAP	Indonesia	LU.S570B.155	AOD150-1Bk AOXPSTID1 MC UMACK 1*1G/160/BT/6L/5R/ CB_bg_0.3D_BAG_GEk_ID23	ATMN280B
AOD150-0Bk	AAP	Philippines	LU.S570B.014	AOD150-0Bk AOXPSTPH1 MC UMACK 1*1G/160/BT/3L/5R/ CB_bg_0.3D_BAG_GEk_EN12	ATMN270B
AOD150-0Bk	AAP	Philippines	LU.S570B.012	AOD150-0Bk AOXPSTPH1 MC UMACK 1*512/160/BT/3L/5R/ CB_bg_0.3D_BAG_GEk_EN12	ATMN270B
AOD150-0Bk	PA	USA	LU.S570B.156	AOD150-0Bk AOXPSTUS1 MC UMACK 1*1G/160/6L/5R/ CB_bg_0.3D_GEk_EN35	ATMN270B
AOD150-1Bk	AAP	Japan	LU.S570B.027	AOD150-1Bk AOXPSTJP1 MC UMACK 1*1G/160/BT/3L/5R/ CB_bg_0.3D_BAG_GEk_JA11_Bk8 3	ATMN280B
AOD150-1Bk	AAP	Japan	LU.S570B.025	AOD150-1Bk AOXPSTJP1 MC UMACK 1*1G/160/BT/3L/5R/ CB_bg_0.3D_BAG_GEk_JA11_Bk8 3f	ATMN280B
AOD150-0Bk	AAP	Japan	LU.S570B.020	AOD150-0Bk AOXPSTJP1 MC UMACK 1*1G/160/BT/3L/5R/ CB_bg_0.3D_BAG_GEk_JA11_Bk7 3f	ATMN270B
AOD150-1Bk	AAP	Singapore	LU.S570B.152	AOD150-1Bk AOXPSTSG1 MC UMACK 1*1G/160/BT/6L/5R/ CB_bg_0.3D_BAG_GEk_EN11	ATMN280B
AOD150-1Bk	AAP	Australia/ New Zealand	LU.S570B.150	AOD150-1Bk AOXPSTAU1 MC UMACK 1*1G/160/BT/6L/5R/ CB_bg_0.3D_BAG_GEk_EN11	ATMN280B
AOD150-0Bk	PA	Canada	LU.S570B.149	AOD150-0Bk AOXPSTCA2 MC UMACK 1*1G/160/6L/5R/ CB_bg_0.3D_GEk_FR31	ATMN270B
AOD150-0Bk	PA	USA	LU.S570B.144	AOD150-0Bk AOXPSTUS1 MC UMACK 1*1G/160/6L/5R/ CB_bg_0.3D_GEk_EN34	ATMN270B
AOD150-0Bk	PA	USA	LU.S570B.145	AOD150-0Bk AOXPSTUS1 MC UMACK 1*1G/160/6L/5R/ CB_bg_0.3D_GEk_EN33	ATMN270B
AOD150-0Bk	PA	Canada	LU.S570B.147	AOD150-0Bk AOXPSTCA2 MC UMACK 1*1G/160/6L/5R/ CB_bg_0.3D_GEk_FR33	ATMN270B

Model	RO	Country	Acer P/N	Description	CPU
AOD150-0Bk	PA	Canada	LU.S570B.148	AOD150-0Bk AOXPSTCA2 MC UMACk 1*1G/160/6L/5R/ CB_bg_0.3D_GEk_FR34	ATMN270B
AOD150-1Bk	EMEA	Eastern Europe	LU.S570B.140	AOD150-1Bk AOXPSTEU7 MC UMACk 1*1G/160/3L/5R/ CB_bg_0.3D_BAG_GEk_ENR2	ATMN280B
AOD150-1Bk	EMEA	Russia	LU.S570B.143	AOD150-1Bk AOXPSTRU1 MC UMACk 1*1G/160/3L/5R/ CB_bg_0.3D_BAG_GEk_RU12	ATMN280B
AOD150-1Bk	EMEA	Austria	LU.S570B.142	AOD150-1Bk AOXPSTAT1 MC UMACk 1*1G/160/3L/5R/ CB_bg_0.3D_BAG_GEk_DE11	ATMN280B
AOD150-1Bk	EMEA	Eastern Europe	LU.S570B.139	AOD150-1Bk AOXPSTEU5 MC UMACk 1*1G/160/3L/5R/ CB_bg_0.3D_BAG_GEk_RO12	ATMN280B
AOD150-1Bk	EMEA	Eastern Europe	LU.S570B.138	AOD150-1Bk AOXPSTEU4 MC UMACk 1*1G/160/3L/5R/ CB_bg_0.3D_BAG_GEk_FI13	ATMN280B
AOD150-1Bk	EMEA	Sweden	LU.S570B.141	AOD150-1Bk AOXPSTSE1 MC UMACk 1*1G/160/3L/5R/ CB_bg_0.3D_BAG_GEk_FI13	ATMN280B
AOD150-1Bk	EMEA	Eastern Europe	LU.S570B.137	AOD150-1Bk AOXPSTEU7 MC UMACk 1*1G/160/3L/5R/ CB_bg_0.3D_BAG_GEk_SL11	ATMN280B
AOD150-1Bk	EMEA	Eastern Europe	LU.S570B.136	AOD150-1Bk AOXPSTEU7 MC UMACk 1*1G/160/3L/5R/ CB_bg_0.3D_BAG_GEk_EN11	ATMN280B
AOD150-1Bk	EMEA	Spain	LU.S570B.127	AOD150-1Bk AOXPSTES1 MC UMACk 1*1G/160/3L/5R/ CB_bg_0.3D_BAG_GEk_ES22	ATMN280B
AOD150-1Bk	EMEA	Hungary	LU.S570B.129	AOD150-1Bk AOXPSTHU1 MC UMACk 1*1G/160/3L/5R/ CB_bg_0.3D_BAG_GEk_HU14	ATMN280B
AOD150-1Bk	EMEA	Portugal	LU.S570B.128	AOD150-1Bk AOXPSTPT1 MC UMACk 1*1G/160/3L/5R/ CB_bg_0.3D_BAG_GEk_PT12	ATMN280B
AOD150-1Bk	EMEA	Eastern Europe	LU.S570B.134	AOD150-1Bk AOXPSTEU5 MC UMACk 1*1G/160/3L/5R/ CB_bg_0.3D_BAG_GEk_PL14	ATMN280B
AOD150-1Bk	EMEA	Finland	LU.S570B.130	AOD150-1Bk AOXPSTFI2 MC UMACk 1*1G/160/3L/5R/ CB_bg_0.3D_BAG_GEk_FI11	ATMN280B
AOD150-1Bk	EMEA	Finland	LU.S570B.131	AOD150-1Bk AOXPSTFI2 MC UMACk 1*1G/160/3L/5R/ CB_bg_0.3D_BAG_GEk_FI31	ATMN280B
AOD150-1Bk	EMEA	Finland	LU.S570B.132	AOD150-1Bk AOXPSTFI2 MC UMACk 1*1G/160/3L/5R/ CB_bg_0.3D_BAG_GEk_FI41	ATMN280B
AOD150-1Bk	EMEA	Finland	LU.S570B.133	AOD150-1Bk AOXPSTFI2 MC UMACk 1*1G/160/3L/5R/ CB_bg_0.3D_BAG_GEk_SV41	ATMN280B
AOD150-1Bk	EMEA	Eastern Europe	LU.S570B.135	AOD150-1Bk AOXPSTEU3 MC UMACk 1*1G/160/3L/5R/ CB_bg_0.3D_BAG_GEk_RU24	ATMN280B
AOD150-1Bk	EMEA	Middle East	LU.S570B.120	AOD150-1Bk EM AOXPSTME3 MC UMACk 1*1G/160/3L/5R/ CB_bg_0.3D_BAG_GEk_FR22	ATMN280B

Model	RO	Country	Acer P/N	Description	CPU
AOD150-1Bk	EMEA	Italy	LU.S570B.124	AOD150-1Bk AOXPHTIT1 MC UMACK 1*1G/160/3L/5R/ CB_bg_0.3D_BAG_GEk_IT12	ATMN280B
AOD150-1Bk	EMEA	Israel	LU.S570B.125	AOD150-1Bk AOXPHTIL1 MC UMACK 1*1G/160/3L/5R/ CB_bg_0.3D_BAG_GEk_HE13	ATMN280B
AOD150-1Bk	EMEA	Middle East	LU.S570B.119	AOD150-1Bk EM AOXPHTME2 MC UMACK 1*1G/160/3L/5R/ CB_bg_0.3D_BAG_GEk_EN12	ATMN280B
AOD150-1Bk	EMEA	Middle East	LU.S570B.121	AOD150-1Bk EM AOXPHTME2 MC UMACK 1*1G/160/3L/5R/ CB_bg_0.3D_BAG_GEk_AR22	ATMN280B
AOD150-1Bk	EMEA	Middle East	LU.S570B.118	AOD150-1Bk EM AOXPHTME4 MC UMACK 1*1G/160/3L/5R/ CB_bg_0.3D_BAG_GEk_EN12	ATMN280B
AOD150-1Bk	EMEA	Greece	LU.S570B.126	AOD150-1Bk AOXPHTGR1 MC UMACK 1*1G/160/3L/5R/ CB_bg_0.3D_BAG_GEk_EL32	ATMN280B
AOD150-1Bk	EMEA	Middle East	LU.S570B.122	AOD150-1Bk EM AOXPHTME9 MC UMACK 1*1G/160/3L/5R/ CB_bg_0.3D_BAG_GEk_FR22	ATMN280B
AOD150-1Bk	EMEA	Middle East	LU.S570B.123	AOD150-1Bk EM AOXPHTME2 MC UMACK 1*1G/160/3L/5R/ CB_bg_0.3D_BAG_GEk_AR12	ATMN280B
AOD150-1Bk	EMEA	Middle East	LU.S570B.117	AOD150-1Bk EM AOXPHTME6 MC UMACK 1*1G/160/3L/5R/ CB_bg_0.3D_BAG_GEk_EN12	ATMN280B
AOD150-1Bk	EMEA	South Africa	LU.S570B.111	AOD150-1Bk EM AOXPHTZA1 MC UMACK 1*1G/160/3L/5R/ CB_bg_0.3D_GEk_FR22	ATMN280B
AOD150-1Bk	EMEA	Turkey	LU.S570B.116	AOD150-1Bk AOXPHTTR1 MC UMACK 1*1G/160/3L/5R/ CB_bg_0.3D_BAG_GEk_TR33	ATMN280B
AOD150-1Bk	EMEA	Denmark	LU.S570B.110	AOD150-1Bk AOXPHTDK1 MC UMACK 1*1G/160/3L/5R/ CB_bg_0.3D_GEk_NO12	ATMN280B
AOD150-1Bk	EMEA	Switzerland	LU.S570B.114	AOD150-1Bk AOXPHTCH1 MC UMACK 1*1G/160/3L/5R/ CB_bg_0.3D_BAG_GEk_IT42	ATMN280B
AOD150-1Bk	EMEA	Germany	LU.S570B.108	AOD150-1Bk AOXPHTDE1 MC UMACK 1*1G/160/3L/5R/ CB_bg_0.3D_GEk_DE12	ATMN280B
AOD150-1Bk	EMEA	South Africa	LU.S570B.112	AOD150-1Bk EM AOXPHTZA2 MC UMACK 1*1G/160/3L/5R/ CB_bg_0.3D_GEk_EN12	ATMN280B
AOD150-1Bk	EMEA	Poland	LU.S570B.115	AOD150-1Bk AOXPHTPL1 MC UMACK 1*1G/160/3L/5R/ CB_bg_0.3D_BAG_GEk_PL11	ATMN280B
AOD150-1Bk	EMEA	Belgium	LU.S570B.107	AOD150-1Bk AOXPHTBE1 MC UMACK 1*1G/160/3L/5R/ CB_bg_0.3D_GEk_NL12	ATMN280B
AOD150-1Bk	EMEA	Ukraine	LU.S570B.113	AOD150-1Bk AOXPHTUK1 MC UMACK 1*1G/160/3L/5R/ CB_bg_0.3D_BAG_GEk_RU11	ATMN280B
AOD150-1Bk	EMEA	France	LU.S570B.109	AOD150-1Bk AOXPHTFR1 MC UMACK 1*1G/160/3L/5R/ CB_bg_0.3D_GEk_FR22	ATMN280B

Model	RO	Country	Acer P/N	Description	CPU
AOD150-1Bk	EMEA	Eastern Europe	LU.S570B.099	AOD150-1Bk AOXPHEU7 MC UMACK 1*1G/160/3L/5R/ CB_bg_0.3D_GEk_ENR2	ATMN280B
AOD150-1Bk	EMEA	Austria	LU.S570B.102	AOD150-1Bk AOXPHEU1 MC UMACK 1*1G/160/3L/5R/ CB_bg_0.3D_GEk_DE11	ATMN280B
AOD150-1Bk	EMEA	Luxembourg	LU.S570B.105	AOD150-1Bk AOXPHEU3 MC UMACK 1*1G/160/3L/5R/ CB_bg_0.3D_GEk_IT41	ATMN280B
AOD150-1Bk	EMEA	Eastern Europe	LU.S570B.098	AOD150-1Bk AOXPHEU5 MC UMACK 1*1G/160/3L/5R/ CB_bg_0.3D_GEk_RO12	ATMN280B
AOD150-1Bk	EMEA	Holland	LU.S570B.106	AOD150-1Bk AOXPHEU11 MC UMACK 1*1G/160/3L/5R/ CB_bg_0.3D_GEk_NL12	ATMN280B
AOD150-1Bk	EMEA	Eastern Europe	LU.S570B.097	AOD150-1Bk AOXPHEU4 MC UMACK 1*1G/160/3L/5R/ CB_bg_0.3D_GEk_FI13	ATMN280B
AOD150-1Bk	EMEA	Sweden	LU.S570B.101	AOD150-1Bk AOXPHEU1 MC UMACK 1*1G/160/3L/5R/ CB_bg_0.3D_GEk_FI13	ATMN280B
AOD150-1Bk	EMEA	Russia	LU.S570B.103	AOD150-1Bk AOXPHEU1 MC UMACK 1*1G/160/3L/5R/ CB_bg_0.3D_GEk_RU12	ATMN280B
AOD150-1Bk	EMEA	Norway	LU.S570B.104	AOD150-1Bk AOXPHEU1 MC UMACK 1*1G/160/3L/5R/ CB_bg_0.3D_GEk_NO12	ATMN280B
AOD150-1Bk	EMEA	Eastern Europe	LU.S570B.096	AOD150-1Bk AOXPHEU7 MC UMACK 1*1G/160/3L/5R/ CB_bg_0.3D_GEk_SL11	ATMN280B
AOD150-1Bk	EMEA	Eastern Europe	LU.S570B.095	AOD150-1Bk AOXPHEU7 MC UMACK 1*1G/160/3L/5R/ CB_bg_0.3D_GEk_EN11	ATMN280B
AOD150-1Bk	EMEA	Portugal	LU.S570B.087	AOD150-1Bk AOXPHEU1 MC UMACK 1*1G/160/3L/5R/ CB_bg_0.3D_GEk_PT12	ATMN280B
AOD150-1Bk	EMEA	Eastern Europe	LU.S570B.093	AOD150-1Bk AOXPHEU5 MC UMACK 1*1G/160/3L/5R/ CB_bg_0.3D_GEk_PL14	ATMN280B
AOD150-1Bk	EMEA	Finland	LU.S570B.089	AOD150-1Bk AOXPHEU12 MC UMACK 1*1G/160/3L/5R/ CB_bg_0.3D_GEk_FI11	ATMN280B
AOD150-1Bk	EMEA	Finland	LU.S570B.090	AOD150-1Bk AOXPHEU12 MC UMACK 1*1G/160/3L/5R/ CB_bg_0.3D_GEk_FI31	ATMN280B
AOD150-1Bk	EMEA	Finland	LU.S570B.091	AOD150-1Bk AOXPHEU12 MC UMACK 1*1G/160/3L/5R/ CB_bg_0.3D_GEk_FI41	ATMN280B
AOD150-1Bk	EMEA	Finland	LU.S570B.092	AOD150-1Bk AOXPHEU12 MC UMACK 1*1G/160/3L/5R/ CB_bg_0.3D_GEk_SV41	ATMN280B
AOD150-1Bk	EMEA	Eastern Europe	LU.S570B.094	AOD150-1Bk AOXPHEU3 MC UMACK 1*1G/160/3L/5R/ CB_bg_0.3D_GEk_RU24	ATMN280B
AOD150-1Bk	EMEA	Spain	LU.S570B.086	AOD150-1Bk AOXPHEU1 MC UMACK 1*1G/160/3L/5R/ CB_bg_0.3D_GEk_ES22	ATMN280B

Model	RO	Country	Acer P/N	Description	CPU
AOD150-1Bk	EMEA	Hungary	LU.S570B.088	AOD150-1Bk AOXPSTHU1 MC UMACK 1*1G/160/3L/5R/ CB_bg_0.3D_GEk_HU14	ATMN280B
AOD150-1Bk	EMEA	Middle East	LU.S570B.079	AOD150-1Bk EM AOXPSTME3 MC UMACk 1*1G/160/3L/5R/ CB_bg_0.3D_GEk_FR22	ATMN280B
AOD150-1Bk	EMEA	Greece	LU.S570B.085	AOD150-1Bk AOXPSTGR1 MC UMACK 1*1G/160/3L/5R/ CB_bg_0.3D_GEk_EL32	ATMN280B
AOD150-1Bk	EMEA	Middle East	LU.S570B.077	AOD150-1Bk EM AOXPSTME4 MC UMACk 1*1G/160/3L/5R/ CB_bg_0.3D_GEk_EN12	ATMN280B
AOD150-1Bk	EMEA	Middle East	LU.S570B.080	AOD150-1Bk EM AOXPSTME2 MC UMACk 1*1G/160/3L/5R/ CB_bg_0.3D_GEk_AR22	ATMN280B
AOD150-1Bk	EMEA	Israel	LU.S570B.084	AOD150-1Bk AOXPSTIL1 MC UMACK 1*1G/160/3L/5R/ CB_bg_0.3D_GEk_HE13	ATMN280B
AOD150-1Bk	EMEA	Italy	LU.S570B.083	AOD150-1Bk AOXPSTIT1 MC UMACK 1*1G/160/3L/5R/ CB_bg_0.3D_GEk_IT12	ATMN280B
AOD150-1Bk	EMEA	Middle East	LU.S570B.078	AOD150-1Bk EM AOXPSTME2 MC UMACk 1*1G/160/3L/5R/ CB_bg_0.3D_GEk_EN12	ATMN280B
AOD150-1Bk	EMEA	Middle East	LU.S570B.082	AOD150-1Bk EM AOXPSTME2 MC UMACk 1*1G/160/3L/5R/ CB_bg_0.3D_GEk_AR12	ATMN280B
AOD150-1Bk	EMEA	Middle East	LU.S570B.076	AOD150-1Bk EM AOXPSTME6 MC UMACk 1*1G/160/3L/5R/ CB_bg_0.3D_GEk_EN12	ATMN280B
AOD150-1Bk	EMEA	Middle East	LU.S570B.081	AOD150-1Bk EM AOXPSTME9 MC UMACk 1*1G/160/3L/5R/ CB_bg_0.3D_GEk_FR22	ATMN280B
AOD150-1Bk	EMEA	Turkey	LU.S570B.075	AOD150-1Bk AOXPSTTR1 MC UMACK 1*1G/160/3L/5R/ CB_bg_0.3D_GEk_TR33	ATMN280B
AOD150-1Bk	EMEA	Ukraine	LU.S570B.072	AOD150-1Bk AOXPSTUK1 MC UMACK 1*1G/160/3L/5R/ CB_bg_0.3D_GEk_RU11	ATMN280B
AOD150-1Bk	EMEA	Switzerland	LU.S570B.073	AOD150-1Bk AOXPSTCH1 MC UMACK 1*1G/160/3L/5R/ CB_bg_0.3D_GEk_IT42	ATMN280B
AOD150-1Bk	EMEA	Poland	LU.S570B.074	AOD150-1Bk AOXPSTPL1 MC UMACK 1*1G/160/3L/5R/ CB_bg_0.3D_GEk_PL11	ATMN280B
AOD150-1Bk	EMEA	UK	LU.S570B.071	AOD150-1Bk AOXPSTGB1 MC UMACK 1*1G/160/3L/5R/ CB_bg_0.3D_GEk_EN12	ATMN280B
AOD150-1Bk	EMEA	South Africa	LU.S570B.069	AOD150-1Bk EM AOXPSTZA1 MC UMACk 1*1G/160/BT/6L/5R/ CB_bg_0.3D_GEk_FR22	ATMN280B
AOD150-1Bk	EMEA	Denmark	LU.S570B.068	AOD150-1Bk AOXPSTDK1 MC UMACK 1*1G/160/BT/6L/5R/ CB_bg_0.3D_GEk_NO12	ATMN280B
AOD150-1Bk	EMEA	South Africa	LU.S570B.070	AOD150-1Bk EM AOXPSTZA2 MC UMACk 1*1G/160/BT/6L/5R/ CB_bg_0.3D_GEk_EN12	ATMN280B

Model	RO	Country	Acer P/N	Description	CPU
AOD150-1Bk	EMEA	Eastern Europe	LU.S570B.058	AOD150-1Bk AOXPSTEU7 MC UMACK 1*1G/160/BT/6L/5R/ CB_bg_0.3D_GEk_ENR2	ATMN280B
AOD150-1Bk	EMEA	Luxembourg	LU.S570B.061	AOD150-1Bk AOXPSTLU3 MC UMACK 1*1G/160/BT/6L/5R/ CB_bg_0.3D_GEk_IT41	ATMN280B
AOD150-1Bk	EMEA	Austria	LU.S570B.060	AOD150-1Bk AOXPSTAT1 MC UMACK 1*1G/160/BT/6L/5R/ CB_bg_0.3D_GEk_DE11	ATMN280B
AOD150-1Bk	EMEA	France	LU.S570B.064	AOD150-1Bk AOXPSTFR1 MC UMACK 1*1G/160/BT/6L/5R/ CB_bg_0.3D_GEk_FR22	ATMN280B
AOD150-1Bk	EMEA	Belgium	LU.S570B.066	AOD150-1Bk AOXPSTBE1 MC UMACK 1*1G/160/BT/6L/5R/ CB_bg_0.3D_GEk_NL12	ATMN280B
AOD150-1Bk	EMEA	Germany	LU.S570B.065	AOD150-1Bk AOXPSTDE1 MC UMACK 1*1G/160/BT/6L/5R/ CB_bg_0.3D_GEk_DE12	ATMN280B
AOD150-1Bk	EMEA	Sweden	LU.S570B.059	AOD150-1Bk AOXPSTSE1 MC UMACK 1*1G/160/BT/6L/5R/ CB_bg_0.3D_GEk_FI13	ATMN280B
AOD150-1Bk	EMEA	Russia	LU.S570B.063	AOD150-1Bk AOXPSTRU1 MC UMACK 1*1G/160/BT/6L/5R/ CB_bg_0.3D_GEk_RU12	ATMN280B
AOD150-1Bk	EMEA	Eastern Europe	LU.S570B.056	AOD150-1Bk AOXPSTEU7 MC UMACK 1*1G/160/BT/6L/5R/ CB_bg_0.3D_GEk_SL11	ATMN280B
AOD150-1Bk	EMEA	Eastern Europe	LU.S570B.052	AOD150-1Bk AOXPSTEU5 MC UMACK 1*1G/160/BT/6L/5R/ CB_bg_0.3D_GEk_PL14	ATMN280B
AOD150-1Bk	EMEA	Eastern Europe	LU.S570B.054	AOD150-1Bk AOXPSTEU5 MC UMACK 1*1G/160/BT/6L/5R/ CB_bg_0.3D_GEk_RO12	ATMN280B
AOD150-1Bk	EMEA	Eastern Europe	LU.S570B.055	AOD150-1Bk AOXPSTEU4 MC UMACK 1*1G/160/BT/6L/5R/ CB_bg_0.3D_GEk_FI13	ATMN280B
AOD150-1Bk	EMEA	Finland	LU.S570B.053	AOD150-1Bk AOXPSTFI2 MC UMACK 1*1G/160/BT/6L/5R/ CB_bg_0.3D_GEk_SV41	ATMN280B
AOD150-1Bk	EMEA	Finland	LU.S570B.050	AOD150-1Bk AOXPSTFI2 MC UMACK 1*1G/160/BT/6L/5R/ CB_bg_0.3D_GEk_FI41	ATMN280B
AOD150-1Bk	EMEA	Finland	LU.S570B.048	AOD150-1Bk AOXPSTFI2 MC UMACK 1*1G/160/BT/6L/5R/ CB_bg_0.3D_GEk_FI11	ATMN280B
AOD150-1Bk	EMEA	Finland	LU.S570B.049	AOD150-1Bk AOXPSTFI2 MC UMACK 1*1G/160/BT/6L/5R/ CB_bg_0.3D_GEk_FI31	ATMN280B
AOD150-1Bk	EMEA	Eastern Europe	LU.S570B.057	AOD150-1Bk AOXPSTEU7 MC UMACK 1*1G/160/BT/6L/5R/ CB_bg_0.3D_GEk_EN11	ATMN280B
AOD150-1Bk	EMEA	Eastern Europe	LU.S570B.051	AOD150-1Bk AOXPSTEU3 MC UMACK 1*1G/160/BT/6L/5R/ CB_bg_0.3D_GEk_RU24	ATMN280B
AOD150-1Bk	EMEA	Hungary	LU.S570B.047	AOD150-1Bk AOXPSTHU1 MC UMACK 1*1G/160/BT/6L/5R/ CB_bg_0.3D_GEk_HU14	ATMN280B

Model	RO	Country	Acer P/N	Description	CPU
AOD150-1Bk	EMEA	Italy	LU.S570B.042	AOD150-1Bk AOXPHTIT1 MC UMACK 1*1G/160/BT/6L/5R/ CB_bg_0.3D_GEk_IT12	ATMN280B
AOD150-1Bk	EMEA	Israel	LU.S570B.041	AOD150-1Bk AOXPHTIL1 MC UMACK 1*1G/160/BT/6L/5R/ CB_bg_0.3D_GEk_HE13	ATMN280B
AOD150-1Bk	EMEA	Middle East	LU.S570B.043	AOD150-1Bk EM AOXPHTME2 MC UMACK 1*1G/160/BT/6L/5R/ CB_bg_0.3D_GEk_AR12	ATMN280B
AOD150-1Bk	EMEA	Portugal	LU.S570B.046	AOD150-1Bk AOXPHTPT1 MC UMACK 1*1G/160/BT/6L/5R/ CB_bg_0.3D_GEk_PT12	ATMN280B
AOD150-1Bk	EMEA	Greece	LU.S570B.044	AOD150-1Bk AOXPHTGR1 MC UMACK 1*1G/160/BT/6L/5R/ CB_bg_0.3D_GEk_EL32	ATMN280B
AOD150-1Bk	EMEA	Middle East	LU.S570B.040	AOD150-1Bk EM AOXPHTME9 MC UMACK 1*1G/160/BT/6L/5R/ CB_bg_0.3D_GEk_FR22	ATMN280B
AOD150-1Bk	EMEA	Spain	LU.S570B.045	AOD150-1Bk AOXPHTES1 MC UMACK 1*1G/160/BT/6L/5R/ CB_bg_0.3D_GEk_ES22	ATMN280B
AOD150-1Bk	EMEA	Middle East	LU.S570B.038	AOD150-1Bk EM AOXPHTME3 MC UMACK 1*1G/160/BT/6L/5R/ CB_bg_0.3D_GEk_FR22	ATMN280B
AOD150-1Bk	EMEA	Middle East	LU.S570B.036	AOD150-1Bk EM AOXPHTME4 MC UMACK 1*1G/160/BT/6L/5R/ CB_bg_0.3D_GEk_EN12	ATMN280B
AOD150-1Bk	EMEA	Middle East	LU.S570B.037	AOD150-1Bk EM AOXPHTME2 MC UMACK 1*1G/160/BT/6L/5R/ CB_bg_0.3D_GEk_EN12	ATMN280B
AOD150-1Bk	EMEA	Poland	LU.S570B.033	AOD150-1Bk AOXPHTPL1 MC UMACK 1*1G/160/BT/6L/5R/ CB_bg_0.3D_GEk_PL11	ATMN280B
AOD150-1Bk	EMEA	Middle East	LU.S570B.035	AOD150-1Bk EM AOXPHTME6 MC UMACK 1*1G/160/BT/6L/5R/ CB_bg_0.3D_GEk_EN12	ATMN280B
AOD150-1Bk	EMEA	Turkey	LU.S570B.034	AOD150-1Bk AOXPHTTR1 MC UMACK 1*1G/160/BT/6L/5R/ CB_bg_0.3D_GEk_TR33	ATMN280B
AOD150-1Bk	EMEA	Ukraine	LU.S570B.031	AOD150-1Bk AOXPHTUK1 MC UMACK 1*1G/160/BT/6L/5R/ CB_bg_0.3D_GEk_RU11	ATMN280B
AOD150-1Bk	EMEA	UK	LU.S570B.030	AOD150-1Bk AOXPHTGB1 MC UMACK 1*1G/160/BT/6L/5R/ CB_bg_0.3D_GEk_EN12	ATMN280B
AOD150-1Bk	EMEA	Switzerland	LU.S570B.032	AOD150-1Bk AOXPHTCH1 MC UMACK 1*1G/160/BT/6L/5R/ CB_bg_0.3D_GEk_IT42	ATMN280B
AOD150-0Bk	PA	Canada	LU.S570B.002	AOD150-0Bk AOXPHTCA2 MC UMACK 1*1G/160/3L/ CB_bg_0.3D_GEk_FR31	ATMN270B
AOD150-0Bk	PA	Canada	LU.S570B.017	AOD150-0Bk AOXPHTCA2 MC UMACK 1*1G/160/3L/ CB_bg_0.3D_GEk_FR33	ATMN270B
AOD150-0Bk	TWN	GCTWN	LU.S570B.004	AOD150-0Bk AOXPHTTW1 MC UMACK 1*1G/160/BT/3L/ CB_bg_0.3D_BAG_GEk_TC11	ATMN270B

Model	RO	Country	Acer P/N	Description	CPU
AOD150-0Bk	AAP	Singapore	LU.S570B.003	AOD150-0Bk AOXPSTSG1 MC UMACk 1*1G/160/BT/6L/ CB_bg_0.3D_BAG_GEk_EN11	ATMN270B
AOD150-0Bk	WW	WW	S2.S570B.001	AOD150-0Bk AOXPSTWW1 MC UMACk 1*1G/160/BT/3L/ CB_bg_0.3D_GEk_EN11	ATMN270B
AOD150-0Bk	PA	USA	LU.S570B.001	AOD150-0Bk AOXPSTUS1 MC UMACk 1*1G/160/3L/ CB_bg_0.3D_GEk_EN31	ATMN270B
AOD150-0Bk	PA	USA	LU.S570B.015	AOD150-0Bk AOXPSTUS1 MC UMACk 1*1G/160/3L/ CB_bg_0.3D_GEk_EN34	ATMN270B
AOD150-0Bk	PA	USA	LU.S570B.016	AOD150-0Bk AOXPSTUS1 MC UMACk 1*1G/160/3L/ CB_bg_0.3D_GEk_EN33	ATMN270B
AOD150-0Bk	CHINA	Hong Kong	LU.S570B.006	AOD150-0Bk AOXPSTHK2 MC UMACk 1*1G/160/3L/ CB_bg_0.3D_BAG_GEk_ZH31	ATMN270B
AOD150-0Bk	CHINA	China	LU.S570B.007	AOD150-0Bk AOXPSTCN1 MC UMACk 1*1G/160/3L/ CB_bg_0.3D_BAG_GEk_SC11	ATMN270B
AOD150-0Bk	PA	Canada	LU.S570B.018	AOD150-0Bk AOXPSTCA2 MC UMACk 1*1G/160/3L/ CB_bg_0.3D_GEk_FR34	ATMN270B
AOD150-0Bk	AAP	Australia/ New Zealand	S2.S570B.004	AOD150-0Bk AOXPSTAU1 MC UMACk 1*1G/160/BT/3L/5R/ CB_bg_0.3D_BAG_GEk_EN11	ATMN270B
AOD150-1Bk	AAP	Australia/ New Zealand	S2.S570B.002	AOD150-1Bk AOXPSTAU1 MC UMACk 1*1G/160/BT/3L/5R/ CB_bg_0.3D_BAG_GEk_EN11	ATMN280B
AOD150-1Br	EMEA	Holland	LU.S560B.049	AOD150-1Br AOXPSTNL1 MC UMACr 1*1G/160/BT/6L/5R/ CB_bg_0.3D_GEk_NL12	ATMN280B
AOD150-1Br	AAP	Thailand	LU.S560B.107	AOD150-1Br AOXPSTTH1 MC UMACr 1*1G/160/BT/3L/5R/ CB_bg_0.3D_BAG_GEk_TH22	ATMN280B
AOD150-0Br	PA	USA	LU.S560B.103	AOD150-0Br AOXPSTUS1 MC UMACr 1*1G/160/6L/5R/ CB_bg_0.3D_GEk_EN31	ATMN270B
AOD150-0Br	AAP	Japan	LU.S560B.014	AOD150-0Br AOXPSTJP1 MC UMACr 1*1G/160/BT/3L/5R/ CB_bg_0.3D_BAG_GEk_JA11_Br7 3	ATMN270B
AOD150-1Br	EMEA	Norway	LU.S560B.047	AOD150-1Br AOXPSTNO1 MC UMACr 1*1G/160/BT/6L/5R/ CB_bg_0.3D_GEk_NO12	ATMN280B
AOD150-0Br	EMEA	France	LU.S560B.123	AOD150-0Br AOXPSTFR1 MC UMACr 1*1G/160/BT/3L/5R/ CB_bg_0.3D_GEk_FR22	ATMN270B
AOD150-0Br	EMEA	France	LU.S560B.122	AOD150-0Br AOXPSTFR1 MC UMACr 1*1G/160/BT/3L/5R/ CB_bg_0.3D_BAG_GEk_FR22	ATMN270B
AOD150-1Br	EMEA	Denmark	LU.S560B.121	AOD150-1Br AOXPSTDK2 MC UMACr 1*1G/160/3L/5R/ CB_bg_0.3D_GEk_ENS1	ATMN280B

Model	RO	Country	Acer P/N	Description	CPU
AOD150-1Br	EMEA	Denmark	LU.S560B.120	AOD150-1Br AOXPSTDK2 MC UMACr 1*1G/160/BT/6L/5R/ CB_bg_0.3D_GEk_ENS1	ATMN280B
AOD150-0Br	PA	ACLA- Spanish	LU.S560B.118	AOD150-0Br EM AOXPSTEA1 MC UMACr 1*1G/160/3L/5R/ CB_bg_0.3D_BAG_GEk_ES21	ATMN270B
AOD150-0Br	PA	ACLA- Spanish	LU.S560B.117	AOD150-0Br EM AOXPSTEA3 MC UMACr 1*1G/160/3L/5R/ CB_bg_0.3D_BAG_GEk_ES21	ATMN270B
AOD150-0Br	PA	ACLA- Spanish	LU.S560B.115	AOD150-0Br EM AOXPSTEA1 MC UMACr 1*1G/160/6L2.6/5R/ CB_bg_0.3D_BAG_GEk_ES21	ATMN270B
AOD150-0Br	PA	ACLA- Portuguese	LU.S560B.116	AOD150-0Br EM AOXPSTXC2 MC UMACr 1*1G/160/6L2.6/5R/ CB_bg_0.3D_BAG_GEk_XC21	ATMN270B
AOD150-0Br	PA	ACLA- Portuguese	LU.S560B.119	AOD150-0Br EM AOXPSTXC2 MC UMACr 1*1G/160/3L/5R/ CB_bg_0.3D_BAG_GEk_XC21	ATMN270B
AOD150-0Br	PA	ACLA- Spanish	LU.S560B.114	AOD150-0Br EM AOXPSTEA3 MC UMACr 1*1G/160/6L2.6/5R/ CB_bg_0.3D_BAG_GEk_ES21	ATMN270B
AOD150-0Br	AAP	Australia/ New Zealand	LU.S560B.113	AOD150-0Br AOXPSTAU1 MC UMACr 1*1G/160/BT/3L/5R/ CB_bg_0.3D_BAG_GEk_EN11	ATMN270B
AOD150-0Br	CHINA	China	LU.S560B.002	AOD150-0Br AOXPSTCN1 MC UMACr 1*1G/160/BT/6L2.6/ CB_bg_0.3D_BAG_GEk_SC11	ATMN270B
AOD150-0Br	CHINA	Hong Kong	LU.S560B.001	AOD150-0Br AOXPSTHK2 MC UMACr 1*1G/160/BT/6L2.6/ CB_bg_0.3D_BAG_GEk_ZH31	ATMN270B
AOD150-0Br	AAP	Japan	LU.S560B.009	AOD150-0Br AOXPSPJP1 MC UMACr 1*1G/160/BT/6L2.6/ CB_bg_0.3D_BAG_GEk_JA11	ATMN270B
AOD150-0Br	AAP	Japan	LU.S560B.013	AOD150-0Br AOXPSPJP1 MC UMACr 1*1G/160/BT/6L2.6/5R/ CB_bg_0.3D_BAG_GEk_JA11_Br7 6	ATMN270B
AOD150-0Br	AAP	Japan	LU.S560B.011	AOD150-0Br AOXPSPJP1 MC UMACr 1*1G/160/BT/6L2.6/5R/ CB_bg_0.3D_BAG_GEk_JA11_Br7 6f	ATMN270B
AOD150-0Br	TWN	GCTWN	LU.S560B.005	AOD150-0Br AOXPSTTW1 MC UMACr 1*1G/160/BT/6L2.6/ CB_bg_0.3D_BAG_GEk_TC11	ATMN270B
AOD150-0Br	AAP	Singapore	LU.S560B.010	AOD150-0Br AOXPSTSG1 MC UMACr 1*1G/160/BT/6L2.6/ CB_bg_0.3D_BAG_GEk_EN11	ATMN270B
AOD150-0Br	AAP	Philippines	LU.S560B.008	AOD150-0Br AOXPSTPH1 MC UMACr 1*1G/160/BT/6L2.6/5R/ CB_bg_0.3D_BAG_GEk_EN12	ATMN270B
AOD150-0Br	AAP	Vietnam	LU.S560B.015	AOD150-0Br AOXPSTVN1 MC UMACr 1*1G/160/6L2.6/5R/ CB_bg_0.3D_BAG_GEk_EN12	ATMN270B
AOD150-0Br	AAP	Indonesia	LU.S560B.109	AOD150-0Br AOXPSTID1 MC UMACr 1*1G/160/BT/3L/5R/ CB_bg_0.3D_BAG_GEk_ID23	ATMN270B

Model	RO	Country	Acer P/N	Description	CPU
AOD150-1Br	AAP	Indonesia	LU.S560B.112	AOD150-1Br AOXPSTID1 MC UMACr 1*1G/160/BT/6L/5R/ CB_bg_0.3D_BAG_GEk_ID23	ATMN280B
AOD150-0Br	AAP	Philippines	LU.S560B.007	AOD150-0Br AOXPSTPH1 MC UMACr 1*1G/160/BT/3L/5R/ CB_bg_0.3D_BAG_GEk_EN12	ATMN270B
AOD150-0Br	AAP	Australia/ New Zealand	LU.S560B.111	AOD150-0Br AOXPSTAU1 MC UMACr 1*1G/160/BT/6L/5R/ CB_bg_0.3D_BAG_GEk_EN11	ATMN270B
AOD150-0Br	AAP	Japan	LU.S560B.110	AOD150-0Br AOXPSTJP1 MC UMACr 1*1G/160/BT/6L/5R/ CB_bg_0.3D_BAG_GEk_JA11	ATMN270B
AOD150-0Br	AAP	Japan	LU.S560B.012	AOD150-0Br AOXPSTJJP1 MC UMACr 1*1G/160/BT/3L/5R/ CB_bg_0.3D_BAG_GEk_JA11_Br7 3f	ATMN270B
AOD150-1Br	AAP	Singapore	LU.S560B.108	AOD150-1Br AOXPSTSG1 MC UMACr 1*1G/160/BT/6L/5R/ CB_bg_0.3D_BAG_GEk_EN11	ATMN280B
AOD150-0Br	PA	USA	LU.S560B.106	AOD150-0Br AOXPSTUS1 MC UMACr 1*1G/160/3L/5R/ CB_bg_0.3D_GEk_EN31	ATMN270B
AOD150-0Br	PA	Canada	LU.S560B.105	AOD150-0Br AOXPSTCA2 MC UMACr 1*1G/160/6L/5R/ CB_bg_0.3D_GEk_FR31	ATMN270B
AOD150-0Br	PA	Canada	LU.S560B.104	AOD150-0Br AOXPSTCA2 MC UMACr 1*1G/160/6L/5R/ CB_bg_0.3D_GEk_FR34	ATMN270B
AOD150-0Br	PA	USA	LU.S560B.101	AOD150-0Br AOXPSTUS1 MC UMACr 1*1G/160/6L/5R/ CB_bg_0.3D_GEk_EN33	ATMN270B
AOD150-0Br	PA	USA	LU.S560B.099	AOD150-0Br AOXPSTUS1 MC UMACr 1*1G/160/6L/5R/ CB_bg_0.3D_GEk_EN35	ATMN270B
AOD150-0Br	PA	Canada	LU.S560B.098	AOD150-0Br AOXPSTCA2 MC UMACr 1*1G/160/3L/5R/ CB_bg_0.3D_GEk_FR31	ATMN270B
AOD150-0Br	PA	Canada	LU.S560B.102	AOD150-0Br AOXPSTCA2 MC UMACr 1*1G/160/6L/5R/ CB_bg_0.3D_GEk_FR33	ATMN270B
AOD150-1Br	EMEA	Denmark	LU.S560B.095	AOD150-1Br AOXPSTDK1 MC UMACr 1*1G/160/3L/5R/ CB_bg_0.3D_GEk_NO12	ATMN280B
AOD150-1Br	EMEA	Germany	LU.S560B.093	AOD150-1Br AOXPSTDE1 MC UMACr 1*1G/160/3L/5R/ CB_bg_0.3D_GEk_DE12	ATMN280B
AOD150-1Br	EMEA	South Africa	LU.S560B.097	AOD150-1Br EM AOXPSTZA2 MC UMACr 1*1G/160/3L/5R/ CB_bg_0.3D_GEk_EN12	ATMN280B
AOD150-1Br	EMEA	France	LU.S560B.094	AOD150-1Br AOXPSTFR1 MC UMACr 1*1G/160/3L/5R/ CB_bg_0.3D_GEk_FR22	ATMN280B
AOD150-1Br	EMEA	South Africa	LU.S560B.096	AOD150-1Br EM AOXPSTZA1 MC UMACr 1*1G/160/3L/5R/ CB_bg_0.3D_GEk_FR22	ATMN280B

Model	RO	Country	Acer P/N	Description	CPU
AOD150-1Br	EMEA	Holland	LU.S560B.091	AOD150-1Br AOXPSTNL1 MC UMACr 1*1G/160/3L/5R/ CB_bg_0.3D_GEk_NL12	ATMN280B
AOD150-1Br	EMEA	Luxembourg	LU.S560B.090	AOD150-1Br AOXPSTLU3 MC UMACr 1*1G/160/3L/5R/ CB_bg_0.3D_GEk_IT41	ATMN280B
AOD150-1Br	EMEA	Norway	LU.S560B.089	AOD150-1Br AOXPSTNO1 MC UMACr 1*1G/160/3L/5R/ CB_bg_0.3D_GEk_NO12	ATMN280B
AOD150-1Br	EMEA	Belgium	LU.S560B.092	AOD150-1Br AOXPSTBE1 MC UMACr 1*1G/160/3L/5R/ CB_bg_0.3D_GEk_NL12	ATMN280B
AOD150-1Br	EMEA	Eastern Europe	LU.S560B.084	AOD150-1Br AOXPSTEU5 MC UMACr 1*1G/160/3L/5R/ CB_bg_0.3D_GEk_RO12	ATMN280B
AOD150-1Br	EMEA	Eastern Europe	LU.S560B.083	AOD150-1Br AOXPSTEU4 MC UMACr 1*1G/160/3L/5R/ CB_bg_0.3D_GEk_FI13	ATMN280B
AOD150-1Br	EMEA	Austria	LU.S560B.087	AOD150-1Br AOXPSTAT1 MC UMACr 1*1G/160/3L/5R/ CB_bg_0.3D_GEk_DE11	ATMN280B
AOD150-1Br	EMEA	Russia	LU.S560B.088	AOD150-1Br AOXPSTRU1 MC UMACr 1*1G/160/3L/5R/ CB_bg_0.3D_GEk_RU12	ATMN280B
AOD150-1Br	EMEA	Eastern Europe	LU.S560B.085	AOD150-1Br AOXPSTEU7 MC UMACr 1*1G/160/3L/5R/ CB_bg_0.3D_GEk_ENR2	ATMN280B
AOD150-1Br	EMEA	Sweden	LU.S560B.086	AOD150-1Br AOXPSTSE1 MC UMACr 1*1G/160/3L/5R/ CB_bg_0.3D_GEk_FI13	ATMN280B
AOD150-1Br	EMEA	Portugal	LU.S560B.073	AOD150-1Br AOXPSTPT1 MC UMACr 1*1G/160/3L/5R/ CB_bg_0.3D_GEk_PT12	ATMN280B
AOD150-1Br	EMEA	Hungary	LU.S560B.074	AOD150-1Br AOXPSTHU1 MC UMACr 1*1G/160/3L/5R/ CB_bg_0.3D_GEk_HU14	ATMN280B
AOD150-1Br	EMEA	Eastern Europe	LU.S560B.080	AOD150-1Br AOXPSTEU3 MC UMACr 1*1G/160/3L/5R/ CB_bg_0.3D_GEk_RU24	ATMN280B
AOD150-1Br	EMEA	Eastern Europe	LU.S560B.081	AOD150-1Br AOXPSTEU7 MC UMACr 1*1G/160/3L/5R/ CB_bg_0.3D_GEk_EN11	ATMN280B
AOD150-1Br	EMEA	Eastern Europe	LU.S560B.082	AOD150-1Br AOXPSTEU7 MC UMACr 1*1G/160/3L/5R/ CB_bg_0.3D_GEk_SL11	ATMN280B
AOD150-1Br	EMEA	Finland	LU.S560B.075	AOD150-1Br AOXPSTFI2 MC UMACr 1*1G/160/3L/5R/ CB_bg_0.3D_GEk_FI11	ATMN280B
AOD150-1Br	EMEA	Finland	LU.S560B.076	AOD150-1Br AOXPSTFI2 MC UMACr 1*1G/160/3L/5R/ CB_bg_0.3D_GEk_FI31	ATMN280B
AOD150-1Br	EMEA	Finland	LU.S560B.077	AOD150-1Br AOXPSTFI2 MC UMACr 1*1G/160/3L/5R/ CB_bg_0.3D_GEk_FI41	ATMN280B
AOD150-1Br	EMEA	Finland	LU.S560B.078	AOD150-1Br AOXPSTFI2 MC UMACr 1*1G/160/3L/5R/ CB_bg_0.3D_GEk_SV41	ATMN280B

Model	RO	Country	Acer P/N	Description	CPU
AOD150-1Br	EMEA	Eastern Europe	LU.S560B.079	AOD150-1Br AOXPHESTU5 MC UMACr 1*1G/160/3L/5R/ CB_bg_0.3D_GEk_PL14	ATMN280B
AOD150-1Br	EMEA	Israel	LU.S560B.070	AOD150-1Br AOXPHESTIL1 MC UMACr 1*1G/160/3L/5R/ CB_bg_0.3D_GEk_HE13	ATMN280B
AOD150-1Br	EMEA	Middle East	LU.S560B.063	AOD150-1Br EM AOXPHESTME4 MC UMACr 1*1G/160/3L/5R/ CB_bg_0.3D_GEk_EN12	ATMN280B
AOD150-1Br	EMEA	Italy	LU.S560B.069	AOD150-1Br AOXPHESTIT1 MC UMACr 1*1G/160/3L/5R/ CB_bg_0.3D_GEk_IT12	ATMN280B
AOD150-1Br	EMEA	Middle East	LU.S560B.067	AOD150-1Br EM AOXPHESTME9 MC UMACr 1*1G/160/3L/5R/ CB_bg_0.3D_GEk_FR22	ATMN280B
AOD150-1Br	EMEA	Middle East	LU.S560B.068	AOD150-1Br EM AOXPHESTME2 MC UMACr 1*1G/160/3L/5R/ CB_bg_0.3D_GEk_AR12	ATMN280B
AOD150-1Br	EMEA	Middle East	LU.S560B.066	AOD150-1Br EM AOXPHESTME2 MC UMACr 1*1G/160/3L/5R/ CB_bg_0.3D_GEk_AR22	ATMN280B
AOD150-1Br	EMEA	Middle East	LU.S560B.065	AOD150-1Br EM AOXPHESTME3 MC UMACr 1*1G/160/3L/5R/ CB_bg_0.3D_GEk_FR22	ATMN280B
AOD150-1Br	EMEA	Greece	LU.S560B.071	AOD150-1Br AOXPHESTGR1 MC UMACr 1*1G/160/3L/5R/ CB_bg_0.3D_GEk_EL32	ATMN280B
AOD150-1Br	EMEA	Spain	LU.S560B.072	AOD150-1Br AOXPHESTES1 MC UMACr 1*1G/160/3L/5R/ CB_bg_0.3D_GEk_ES22	ATMN280B
AOD150-1Br	EMEA	Middle East	LU.S560B.064	AOD150-1Br EM AOXPHESTME2 MC UMACr 1*1G/160/3L/5R/ CB_bg_0.3D_GEk_EN12	ATMN280B
AOD150-1Br	EMEA	Middle East	LU.S560B.062	AOD150-1Br EM AOXPHESTME6 MC UMACr 1*1G/160/3L/5R/ CB_bg_0.3D_GEk_EN12	ATMN280B
AOD150-1Br	EMEA	Poland	LU.S560B.060	AOD150-1Br AOXPHESTPL1 MC UMACr 1*1G/160/3L/5R/ CB_bg_0.3D_GEk_PL11	ATMN280B
AOD150-1Br	EMEA	Turkey	LU.S560B.061	AOD150-1Br AOXPHESTTR1 MC UMACr 1*1G/160/3L/5R/ CB_bg_0.3D_GEk_TR33	ATMN280B
AOD150-1Br	EMEA	UK	LU.S560B.057	AOD150-1Br AOXPHESTGB1 MC UMACr 1*1G/160/3L/5R/ CB_bg_0.3D_GEk_EN12	ATMN280B
AOD150-1Br	EMEA	Ukraine	LU.S560B.058	AOD150-1Br AOXPHESTUK1 MC UMACr 1*1G/160/3L/5R/ CB_bg_0.3D_GEk_RU11	ATMN280B
AOD150-1Br	EMEA	Switzerland	LU.S560B.059	AOD150-1Br AOXPHESTCH1 MC UMACr 1*1G/160/3L/5R/ CB_bg_0.3D_GEk_IT42	ATMN280B
AOD150-1Br	EMEA	Eastern Europe	LU.S560B.056	AOD150-1Br AOXPHESTU5 MC UMACr 1*1G/160/BT/6L/5R/ CB_bg_0.3D_GEk_PL14	ATMN280B
AOD150-1Br	EMEA	South Africa	LU.S560B.055	AOD150-1Br EM AOXPHESTZA2 MC UMACr 1*1G/160/BT/6L/5R/ CB_bg_0.3D_GEk_EN12	ATMN280B

Model	RO	Country	Acer P/N	Description	CPU
AOD150-1Br	EMEA	South Africa	LU.S560B.054	AOD150-1Br EM AOXPSTZA1 MC UMACr 1*1G/160/BT/6L/5R/ CB_bg_0.3D_GEk_FR22	ATMN280B
AOD150-1Br	EMEA	Denmark	LU.S560B.053	AOD150-1Br AOXPSTDK1 MC UMACr 1*1G/160/BT/6L/5R/ CB_bg_0.3D_GEk_NO12	ATMN280B
AOD150-1Br	EMEA	Russia	LU.S560B.046	AOD150-1Br AOXPSTRU1 MC UMACr 1*1G/160/BT/6L/5R/ CB_bg_0.3D_GEk_RU12	ATMN280B
AOD150-1Br	EMEA	Austria	LU.S560B.045	AOD150-1Br AOXPSTAT1 MC UMACr 1*1G/160/BT/6L/5R/ CB_bg_0.3D_GEk_DE11	ATMN280B
AOD150-1Br	EMEA	France	LU.S560B.052	AOD150-1Br AOXPSTFR1 MC UMACr 1*1G/160/BT/6L/5R/ CB_bg_0.3D_GEk_FR22	ATMN280B
AOD150-1Br	EMEA	Belgium	LU.S560B.050	AOD150-1Br AOXPSTBE1 MC UMACr 1*1G/160/BT/6L/5R/ CB_bg_0.3D_GEk_NL12	ATMN280B
AOD150-1Br	EMEA	Luxembourg	LU.S560B.048	AOD150-1Br AOXPSTLU3 MC UMACr 1*1G/160/BT/6L/5R/ CB_bg_0.3D_GEk_IT41	ATMN280B
AOD150-1Br	EMEA	Germany	LU.S560B.051	AOD150-1Br AOXPSTDE1 MC UMACr 1*1G/160/BT/6L/5R/ CB_bg_0.3D_GEk_DE12	ATMN280B
AOD150-1Br	EMEA	Eastern Europe	LU.S560B.042	AOD150-1Br AOXPSTEU5 MC UMACr 1*1G/160/BT/6L/5R/ CB_bg_0.3D_GEk_RO12	ATMN280B
AOD150-1Br	EMEA	Eastern Europe	LU.S560B.040	AOD150-1Br AOXPSTEU7 MC UMACr 1*1G/160/BT/6L/5R/ CB_bg_0.3D_GEk_SL11	ATMN280B
AOD150-1Br	EMEA	Eastern Europe	LU.S560B.038	AOD150-1Br AOXPSTEU3 MC UMACr 1*1G/160/BT/6L/5R/ CB_bg_0.3D_GEk_RU24	ATMN280B
AOD150-1Br	EMEA	Eastern Europe	LU.S560B.039	AOD150-1Br AOXPSTEU7 MC UMACr 1*1G/160/BT/6L/5R/ CB_bg_0.3D_GEk_EN11	ATMN280B
AOD150-1Br	EMEA	Eastern Europe	LU.S560B.043	AOD150-1Br AOXPSTEU7 MC UMACr 1*1G/160/BT/6L/5R/ CB_bg_0.3D_GEk_ENR2	ATMN280B
AOD150-1Br	EMEA	Eastern Europe	LU.S560B.041	AOD150-1Br AOXPSTEU4 MC UMACr 1*1G/160/BT/6L/5R/ CB_bg_0.3D_GEk_FI13	ATMN280B
AOD150-1Br	EMEA	Sweden	LU.S560B.044	AOD150-1Br AOXPSTSE1 MC UMACr 1*1G/160/BT/6L/5R/ CB_bg_0.3D_GEk_FI13	ATMN280B
AOD150-1Br	EMEA	Finland	LU.S560B.035	AOD150-1Br AOXPSTFI2 MC UMACr 1*1G/160/BT/6L/5R/ CB_bg_0.3D_GEk_FI31	ATMN280B
AOD150-1Br	EMEA	Finland	LU.S560B.036	AOD150-1Br AOXPSTFI2 MC UMACr 1*1G/160/BT/6L/5R/ CB_bg_0.3D_GEk_FI41	ATMN280B
AOD150-1Br	EMEA	Finland	LU.S560B.037	AOD150-1Br AOXPSTFI2 MC UMACr 1*1G/160/BT/6L/5R/ CB_bg_0.3D_GEk_SV41	ATMN280B
AOD150-1Br	EMEA	Portugal	LU.S560B.033	AOD150-1Br AOXPSTPT1 MC UMACr 1*1G/160/BT/6L/5R/ CB_bg_0.3D_GEk_PT12	ATMN280B

Model	RO	Country	Acer P/N	Description	CPU
AOD150-1Br	EMEA	Middle East	LU.S560B.025	AOD150-1Br EM AOXPSTME4 MC UMACr 1*1G/160/BT/6L/5R/ CB_bg_0.3D_GEk_EN12	ATMN280B
AOD150-1Br	EMEA	Italy	LU.S560B.030	AOD150-1Br AOXPSTIT1 MC UMACr 1*1G/160/BT/6L/5R/ CB_bg_0.3D_GEk_IT12	ATMN280B
AOD150-1Br	EMEA	Middle East	LU.S560B.026	AOD150-1Br EM AOXPSTME9 MC UMACr 1*1G/160/BT/6L/5R/ CB_bg_0.3D_GEk_FR22	ATMN280B
AOD150-1Br	EMEA	Greece	LU.S560B.028	AOD150-1Br AOXPSTGR1 MC UMACr 1*1G/160/BT/6L/5R/ CB_bg_0.3D_GEk_EL32	ATMN280B
AOD150-1Br	EMEA	Spain	LU.S560B.034	AOD150-1Br AOXPSTES1 MC UMACr 1*1G/160/BT/6L/5R/ CB_bg_0.3D_GEk_ES22	ATMN280B
AOD150-1Br	EMEA	Middle East	LU.S560B.027	AOD150-1Br EM AOXPSTME2 MC UMACr 1*1G/160/BT/6L/5R/ CB_bg_0.3D_GEk_AR12	ATMN280B
AOD150-1Br	EMEA	Finland	LU.S560B.031	AOD150-1Br AOXPSTFI2 MC UMACr 1*1G/160/BT/6L/5R/ CB_bg_0.3D_GEk_FI11	ATMN280B
AOD150-1Br	EMEA	Israel	LU.S560B.029	AOD150-1Br AOXPSTIL1 MC UMACr 1*1G/160/BT/6L/5R/ CB_bg_0.3D_GEk_HE13	ATMN280B
AOD150-1Br	EMEA	Hungary	LU.S560B.032	AOD150-1Br AOXPSTHU1 MC UMACr 1*1G/160/BT/6L/5R/ CB_bg_0.3D_GEk_HU14	ATMN280B
AOD150-1Br	EMEA	Middle East	LU.S560B.019	AOD150-1Br EM AOXPSTME6 MC UMACr 1*1G/160/BT/6L/5R/ CB_bg_0.3D_GEk_EN12	ATMN280B
AOD150-1Br	EMEA	Switzerland	LU.S560B.018	AOD150-1Br AOXPSTCH1 MC UMACr 1*1G/160/BT/6L/5R/ CB_bg_0.3D_GEk_IT42	ATMN280B
AOD150-1Br	EMEA	Middle East	LU.S560B.023	AOD150-1Br EM AOXPSTME3 MC UMACr 1*1G/160/BT/6L/5R/ CB_bg_0.3D_GEk_FR22	ATMN280B
AOD150-1Br	EMEA	Ukraine	LU.S560B.017	AOD150-1Br AOXPSTUK1 MC UMACr 1*1G/160/BT/6L/5R/ CB_bg_0.3D_GEk_RU11	ATMN280B
AOD150-1Br	EMEA	Turkey	LU.S560B.020	AOD150-1Br AOXPSTTR1 MC UMACr 1*1G/160/BT/6L/5R/ CB_bg_0.3D_GEk_TR33	ATMN280B
AOD150-1Br	EMEA	UK	LU.S560B.016	AOD150-1Br AOXPSTGB1 MC UMACr 1*1G/160/BT/6L/5R/ CB_bg_0.3D_GEk_EN12	ATMN280B
AOD150-1Br	EMEA	Middle East	LU.S560B.022	AOD150-1Br EM AOXPSTME2 MC UMACr 1*1G/160/BT/6L/5R/ CB_bg_0.3D_GEk_AR22	ATMN280B
AOD150-1Br	EMEA	Middle East	LU.S560B.024	AOD150-1Br EM AOXPSTME2 MC UMACr 1*1G/160/BT/6L/5R/ CB_bg_0.3D_GEk_EN12	ATMN280B
AOD150-1Br	EMEA	Poland	LU.S560B.021	AOD150-1Br AOXPSTPL1 MC UMACr 1*1G/160/BT/6L/5R/ CB_bg_0.3D_GEk_PL11	ATMN280B
AOD150-0Br	CHINA	Hong Kong	LU.S560B.004	AOD150-0Br AOXPSTHK2 MC UMACr 1*1G/160/3L/ CB_bg_0.3D_BAG_GEk_ZH31	ATMN270B

Model	RO	Country	Acer P/N	Description	CPU
AOD150-0Br	TWN	GCTWN	LU.S560B.006	AOD150-0Br AOXPSTTW1 MC UMACr 1*1G/160/BT/3L/ CB_bg_0.3D_BAG_GEk_TC11	ATMN270B
AOD150-0Br	CHINA	China	LU.S560B.003	AOD150-0Br AOXPSTCN1 MC UMACr 1*1G/160/3L/ CB_bg_0.3D_BAG_GEk_SC11	ATMN270B
AOD150-1Bw	EMEA	Belgium	LU.S550B.055	AOD150-1Bw AOXPSTBE1 MC UMACw 1*1G/160/BT/6L/5R/ CB_bg_0.3D_GEW_NL12	ATMN280B
AOD150-0Bw	CHINA	China	LU.S550B.133	AOD150-0Bw AOXPSTCN1 MC UMACw 1*1G/160/BT/3L/5R/ CB_bg_0.3D_BAG_GEW_SC11	ATMN270B
AOD150-1Bw	EMEA	Holland	LU.S550B.056	AOD150-1Bw AOXPSTNL1 MC UMACw 1*1G/160/BT/6L/5R/ CB_bg_0.3D_GEW_NL12	ATMN280B
AOD150-1Bw	EMEA	Finland	LU.S550B.084	AOD150-1Bw AOXPSTFI2 MC UMACw 1*1G/160/3L/5R/ CB_bg_0.3D_GEW_FI11	ATMN280B
AOD150-1Bw	EMEA	Italy	LU.S550B.034	AOD150-1Bw AOXPSTIT1 MC UMACw 1*1G/160/BT/6L/5R/ CB_bg_0.3D_GEW_IT12	ATMN280B
AOD150-1Bw	EMEA	Luxembourg	LU.S550B.057	AOD150-1Bw AOXPSTLU3 MC UMACw 1*1G/160/BT/6L/5R/ CB_bg_0.3D_GEW_IT41	ATMN280B
AOD150-0Bw	PA	USA	LU.S550B.111	AOD150-0Bw AOXPSTUS1 MC UMACw 1*1G/160/6L/5R/ CB_bg_0.3D_GEW_EN31	ATMN270B
AOD150-0Bw	EMEA	France	LU.S550B.132	AOD150-0Bw AOXPSTFR1 MC UMACw 1*1G/160/BT/3L/5R/ CB_bg_0.3D_GEW_FR22	ATMN270B
AOD150-0Bw	PA	ACLA- Spanish	LU.S550B.126	AOD150-0Bw EM AOXPSTEA1 MC UMACw 1*1G/160/3L/5R/ CB_bg_0.3D_BAG_GEW_ES21	ATMN270B
AOD150-1Bw	EMEA	Russia	LU.S550B.053	AOD150-1Bw AOXPSTRU1 MC UMACw 1*1G/160/BT/6L/5R/ CB_bg_0.3D_GEW_RU12	ATMN280B
AOD150-0Bw	CHINA	China	LU.S550B.002	AOD150-0Bw AOXPSTCN1 MC UMACw 1*1G/160/3L/ CB_bg_0.3D_BAG_GEW_SC11	ATMN270B
AOD150-1Bw	EMEA	Norway	LU.S550B.054	AOD150-1Bw AOXPSTNO1 MC UMACw 1*1G/160/BT/6L/5R/ CB_bg_0.3D_GEW_NO12	ATMN280B
AOD150-0Bw	AAP	Australia/ New Zealand	LU.S550B.117	AOD150-0Bw AOXPSTAU1 MC UMACw 1*1G/160/BT/6L/5R/ CB_bg_0.3D_BAG_GEW_EN11	ATMN270B
AOD150-1Bw	EMEA	Germany	LU.S550B.061	AOD150-1Bw AOXPSTDE1 MC UMACw 1*1G/160/BT/6L/5R/ CB_bg_0.3D_GEW_DE12	ATMN280B
AOD150-1Bw	EMEA	Spain	LU.S550B.035	AOD150-1Bw AOXPSTES1 MC UMACw 1*1G/160/BT/6L/5R/ CB_bg_0.3D_GEW_ES22	ATMN280B
AOD150-1Bw	EMEA	Spain	LU.S550B.081	AOD150-1Bw AOXPSTES1 MC UMACw 1*1G/160/3L/5R/ CB_bg_0.3D_GEW_ES22	ATMN280B
AOD150-0Bw	AAP	Singapore	LU.S550B.127	AOD150-0Bw AOXPSTSG1 MC UMACw 1*1G/160/BT/6L/5R/ CB_bg_0.3D_BAG_GEW_EN11	ATMN270B

Model	RO	Country	Acer P/N	Description	CPU
AOD150-0Bw	AAP	Australia/ New Zealand	LU.S550B.120	AOD150-0Bw AOXPSTAU1 MC UMACw 1*1G/160/BT/3L/5R/ CB_bg_0.3D_BAG_GEW_EN11	ATMN270B
AOD150-0Bw	EMEA	France	LU.S550B.131	AOD150-0Bw AOXPSTFR1 MC UMACw 1*1G/160/3L/5R/ CB_bg_0.3D_BAG_GEW_FR22	ATMN270B
AOD150-1Bw	EMEA	Denmark	LU.S550B.129	AOD150-1Bw AOXPSTDK2 MC UMACw 1*1G/160/BT/6L/5R/ CB_bg_0.3D_GEW_ENS1	ATMN280B
AOD150-1Bw	EMEA	Denmark	LU.S550B.130	AOD150-1Bw AOXPSTDK2 MC UMACw 1*1G/160/3L/5R/ CB_bg_0.3D_GEW_ENS1	ATMN280B
AOD150-0Bw	AAP	Indonesia	LU.S550B.128	AOD150-0Bw AOXPSTID1 MC UMACw 1*1G/160/BT/6L/5R/ CB_bg_0.3D_BAG_GEW_ID23	ATMN270B
AOD150-0Bw	WW	WW	S2.S550B.003	AOD150-0Bw AOXPSTWW1 MC UMACw 1*1G/160/BT/6L2.6/5R/ CB_bg_0.3D_GEW_EN11	ATMN270B
AOD150-1Bw	EMEA	Hungary	LU.S550B.040	AOD150-1Bw AOXPSTHU1 MC UMACw 1*1G/160/BT/6L/5R/ CB_bg_0.3D_GEW_HU14	ATMN280B
AOD150-1Bw	AAP	Philippines	LU.S550B.118	AOD150-1Bw AOXPSTPH1 MC UMACw 1*1G/160/BT/6L2.6/5R/ CB_bg_0.3D_BAG_GEW_EN12	ATMN280B
AOD150-1Bw	AAP	Indonesia	LU.S550B.119	AOD150-1Bw AOXPSTID1 MC UMACw 1*1G/160/BT/6L/5R/ CB_bg_0.3D_BAG_GEW_ID23	ATMN280B
AOD150-0Bw	PA	ACLA- Portuguese	LU.S550B.125	AOD150-0Bw EM AOXPSTXC2 MC UMACw 1*1G/160/3L/5R/ CB_bg_0.3D_BAG_GEW_XC21	ATMN270B
AOD150-0Bw	PA	ACLA- Spanish	LU.S550B.124	AOD150-0Bw EM AOXPSTEA3 MC UMACw 1*1G/160/3L/5R/ CB_bg_0.3D_BAG_GEW_ES21	ATMN270B
AOD150-0Bw	PA	ACLA- Spanish	LU.S550B.121	AOD150-0Bw EM AOXPSTEA3 MC UMACw 1*1G/160/6L2.6/5R/ CB_bg_0.3D_BAG_GEW_ES21	ATMN270B
AOD150-0Bw	PA	ACLA- Spanish	LU.S550B.123	AOD150-0Bw EM AOXPSTEA1 MC UMACw 1*1G/160/6L2.6/5R/ CB_bg_0.3D_BAG_GEW_ES21	ATMN270B
AOD150-0Bw	PA	ACLA- Portuguese	LU.S550B.122	AOD150-0Bw EM AOXPSTXC2 MC UMACw 1*1G/160/6L2.6/5R/ CB_bg_0.3D_BAG_GEW_XC21	ATMN270B
AOD150-0Bw	AAP	Malaysia	LU.S550B.009	AOD150-0Bw AOXPSTMY1 MC UMACw 1*1G/160/BT/6L/5R/ CB_bg_0.3D_BAG_GEW_EN12	ATMN270B
AOD150-1Bw	AAP	Indonesia	LU.S550B.114	AOD150-1Bw AOXPSTID1 MC UMACw 1*1G/160/BT/6L2.6/5R/ CB_bg_0.3D_BAG_GEW_ID23	ATMN280B
AOD150-0Bw	TWN	GCTWN	LU.S550B.005	AOD150-0Bw AOXPSTTW1 MC UMACw 1*1G/160/BT/6L2.6/ CB_bg_0.3D_BAG_GEW_TC11	ATMN270B
AOD150-1Bw	AAP	Japan	LU.S550B.015	AOD150-1Bw AOXPSTJP1 MC UMACw 1*1G/160/BT/6L2.6/5R/ CB_bg_0.3D_BAG_GEW_JA11_Bw 86	ATMN280B

Model	RO	Country	Acer P/N	Description	CPU
AOD150-0Bw	AAP	Japan	LU.S550B.011	AOD150-0Bw AOXPHSPJP1 MC UMACw 1*1G/160/BT/6L2.6/5R/ CB_bg_0.3D_BAG_GEW_JA11_Bw 76f	ATMN270B
AOD150-0Bw	AAP	Japan	LU.S550B.013	AOD150-0Bw AOXPHSJP1 MC UMACw 1*1G/160/BT/6L2.6/5R/ CB_bg_0.3D_BAG_GEW_JA11_Bw 76	ATMN270B
AOD150-1Bw	AAP	Japan	LU.S550B.016	AOD150-1Bw AOXPHSPJP1 MC UMACw 1*1G/160/BT/6L2.6/5R/ CB_bg_0.3D_BAG_GEW_JA11_Bw 86f	ATMN280B
AOD150-0Bw	CHINA	China	LU.S550B.003	AOD150-0Bw AOXPHSTCN1 MC UMACw 1*1G/160/BT/6L2.6/ CB_bg_0.3D_BAG_GEW_SC11	ATMN270B
AOD150-0Bw	CHINA	Hong Kong	LU.S550B.004	AOD150-0Bw AOXPHSTHK2 MC UMACw 1*1G/160/BT/6L2.6/ CB_bg_0.3D_BAG_GEW_ZH31	ATMN270B
AOD150-0Bw	AAP	Vietnam	LU.S550B.014	AOD150-0Bw AOXPHSTVN1 MC UMACw 1*1G/160/3L/5R/ CB_bg_0.3D_BAG_GEW_EN12	ATMN270B
AOD150-1Bw	AAP	Thailand	LU.S550B.113	AOD150-1Bw AOXPHSTTH1 MC UMACw 1*1G/160/3L/5R/ CB_bg_0.3D_BAG_GEW_TH22	ATMN280B
AOD150-1Bw	AAP	Thailand	LU.S550B.021	AOD150-1Bw AOXPHSTTH1 MC UMACw 1*1G/160/BT/3L/5R/ CB_bg_0.3D_BAG_GEW_TH22	ATMN280B
AOD150-0Bw	AAP	Philippines	LU.S550B.116	AOD150-0Bw AOXPHSTPH1 MC UMACw 1*1G/160/BT/6L/5R/ CB_bg_0.3D_BAG_GEW_EN12	ATMN270B
AOD150-0Bw	CHINA	Hong Kong	LU.S550B.115	AOD150-0Bw AOXPHSTHK2 MC UMACw 1*1G/160/BT/3L/5R/ CB_bg_0.3D_BAG_GEW_ZH31	ATMN270B
AOD150-1Bw	AAP	Japan	LU.S550B.018	AOD150-1Bw AOXPHSJP1 MC UMACw 1*1G/160/BT/3L/5R/ CB_bg_0.3D_BAG_GEW_JA11_Bw 83	ATMN280B
AOD150-1Bw	AAP	Japan	LU.S550B.017	AOD150-1Bw AOXPHSPJP1 MC UMACw 1*1G/160/BT/3L/5R/ CB_bg_0.3D_BAG_GEW_JA11_Bw 83f	ATMN280B
AOD150-0Bw	AAP	Japan	LU.S550B.012	AOD150-0Bw AOXPHSPJP1 MC UMACw 1*1G/160/BT/3L/5R/ CB_bg_0.3D_BAG_GEW_JA11_Bw 76f	ATMN270B
AOD150-0Bw	AAP	Japan	LU.S550B.010	AOD150-0Bw AOXPHSJP1 MC UMACw 1*1G/160/BT/3L/5R/ CB_bg_0.3D_BAG_GEW_JA11_Bw 73	ATMN270B
AOD150-0Bw	PA	Canada	LU.S550B.112	AOD150-0Bw AOXPHSTCA2 MC UMACw 1*1G/160/6L/5R/ CB_bg_0.3D_GEW_FR31	ATMN270B
AOD150-0Bw	PA	USA	LU.S550B.108	AOD150-0Bw AOXPHSTUS1 MC UMACw 1*1G/160/6L/5R/ CB_bg_0.3D_GEW_EN33	ATMN270B
AOD150-0Bw	PA	USA	LU.S550B.107	AOD150-0Bw AOXPHSTUS1 MC UMACw 1*1G/160/6L/5R/ CB_bg_0.3D_GEW_EN35	ATMN270B

Model	RO	Country	Acer P/N	Description	CPU
AOD150-0Bw	PA	Canada	LU.S550B.110	AOD150-0Bw AOXPSTCA2 MC UMACw 1*1G/160/6L/5R/ CB_bg_0.3D_GEW_FR33	ATMN270B
AOD150-0Bw	PA	Canada	LU.S550B.109	AOD150-0Bw AOXPSTCA2 MC UMACw 1*1G/160/6L/5R/ CB_bg_0.3D_GEW_FR34	ATMN270B
AOD150-1Bw	AAP	Singapore	LU.S550B.106	AOD150-1Bw AOXPSTSG1 MC UMACw 1*1G/160/6L/5R/ CB_bg_0.3D_BAG_GEW_EN11	ATMN280B
AOD150-1Bw	AAP	Japan	LU.S550B.105	AOD150-1Bw AOXPSTJP1 MC UMACw 1*1G/160/BT/6L/5R/ CB_bg_0.3D_BAG_GEW_JA11	ATMN280B
AOD150-1Bw	EMEA	South Africa	LU.S550B.104	AOD150-1Bw EM AOXPSTZA2 MC UMACw 1*1G/160/3L/5R/ CB_bg_0.3D_GEW_EN12	ATMN280B
AOD150-1Bw	EMEA	South Africa	LU.S550B.103	AOD150-1Bw EM AOXPSTZA1 MC UMACw 1*1G/160/3L/5R/ CB_bg_0.3D_GEW_FR22	ATMN280B
AOD150-1Bw	EMEA	France	LU.S550B.101	AOD150-1Bw AOXPSTFR1 MC UMACw 1*1G/160/3L/5R/ CB_bg_0.3D_GEW_FR22	ATMN280B
AOD150-1Bw	EMEA	Denmark	LU.S550B.102	AOD150-1Bw AOXPSTDK1 MC UMACw 1*1G/160/3L/5R/ CB_bg_0.3D_GEW_NO12	ATMN280B
AOD150-1Bw	EMEA	Norway	LU.S550B.093	AOD150-1Bw AOXPSTNO1 MC UMACw 1*1G/160/3L/5R/ CB_bg_0.3D_GEW_NO12	ATMN280B
AOD150-1Bw	EMEA	Austria	LU.S550B.095	AOD150-1Bw AOXPSTAT1 MC UMACw 1*1G/160/3L/5R/ CB_bg_0.3D_GEW_DE11	ATMN280B
AOD150-1Bw	EMEA	Germany	LU.S550B.096	AOD150-1Bw AOXPSTDE1 MC UMACw 1*1G/160/3L/5R/ CB_bg_0.3D_GEW_DE12	ATMN280B
AOD150-1Bw	EMEA	Luxembourg	LU.S550B.099	AOD150-1Bw AOXPSTLU3 MC UMACw 1*1G/160/3L/5R/ CB_bg_0.3D_GEW_IT41	ATMN280B
AOD150-1Bw	EMEA	Sweden	LU.S550B.092	AOD150-1Bw AOXPSTSE1 MC UMACw 1*1G/160/3L/5R/ CB_bg_0.3D_GEW_FI13	ATMN280B
AOD150-1Bw	EMEA	Eastern Europe	LU.S550B.090	AOD150-1Bw AOXPSTEU5 MC UMACw 1*1G/160/3L/5R/ CB_bg_0.3D_GEW_RO12	ATMN280B
AOD150-1Bw	EMEA	Holland	LU.S550B.098	AOD150-1Bw AOXPSTNL1 MC UMACw 1*1G/160/3L/5R/ CB_bg_0.3D_GEW_NL12	ATMN280B
AOD150-1Bw	EMEA	Russia	LU.S550B.094	AOD150-1Bw AOXPSTRU1 MC UMACw 1*1G/160/3L/5R/ CB_bg_0.3D_GEW_RU12	ATMN280B
AOD150-1Bw	EMEA	Belgium	LU.S550B.097	AOD150-1Bw AOXPSTBE1 MC UMACw 1*1G/160/3L/5R/ CB_bg_0.3D_GEW_NL12	ATMN280B
AOD150-1Bw	EMEA	Eastern Europe	LU.S550B.091	AOD150-1Bw AOXPSTEU7 MC UMACw 1*1G/160/3L/5R/ CB_bg_0.3D_GEW_ENR2	ATMN280B
AOD150-1Bw	EMEA	Eastern Europe	LU.S550B.088	AOD150-1Bw AOXPSTEU7 MC UMACw 1*1G/160/3L/5R/ CB_bg_0.3D_GEW_SL11	ATMN280B

Model	RO	Country	Acer P/N	Description	CPU
AOD150-1Bw	EMEA	Eastern Europe	LU.S550B.089	AOD150-1Bw AOXPSTEU4 MC UMACw 1*1G/160/3L/5R/ CB_bg_0.3D_GEW_FI13	ATMN280B
AOD150-1Bw	EMEA	Greece	LU.S550B.080	AOD150-1Bw AOXPSTGR1 MC UMACw 1*1G/160/3L/5R/ CB_bg_0.3D_GEW_EL32	ATMN280B
AOD150-1Bw	EMEA	Hungary	LU.S550B.085	AOD150-1Bw AOXPSTHU1 MC UMACw 1*1G/160/3L/5R/ CB_bg_0.3D_GEW_HU14	ATMN280B
AOD150-1Bw	EMEA	Finland	LU.S550B.086	AOD150-1Bw AOXPSTFI2 MC UMACw 1*1G/160/3L/5R/ CB_bg_0.3D_GEW_SV41	ATMN280B
AOD150-1Bw	EMEA	Finland	LU.S550B.087	AOD150-1Bw AOXPSTFI2 MC UMACw 1*1G/160/3L/5R/ CB_bg_0.3D_GEW_FI41	ATMN280B
AOD150-1Bw	EMEA	Portugal	LU.S550B.082	AOD150-1Bw AOXPSTPT1 MC UMACw 1*1G/160/3L/5R/ CB_bg_0.3D_GEW_PT12	ATMN280B
AOD150-1Bw	EMEA	Finland	LU.S550B.083	AOD150-1Bw AOXPSTFI2 MC UMACw 1*1G/160/3L/5R/ CB_bg_0.3D_GEW_FI31	ATMN280B
AOD150-1Bw	EMEA	Turkey	LU.S550B.070	AOD150-1Bw AOXPSTTR1 MC UMACw 1*1G/160/3L/5R/ CB_bg_0.3D_GEW_TR33	ATMN280B
AOD150-1Bw	EMEA	Israel	LU.S550B.076	AOD150-1Bw AOXPSTIL1 MC UMACw 1*1G/160/3L/5R/ CB_bg_0.3D_GEW_HE13	ATMN280B
AOD150-1Bw	EMEA	Middle East	LU.S550B.072	AOD150-1Bw EM AOXPSTME4 MC UMACw 1*1G/160/3L/5R/ CB_bg_0.3D_GEW_EN12	ATMN280B
AOD150-1Bw	EMEA	Middle East	LU.S550B.074	AOD150-1Bw EM AOXPSTME3 MC UMACw 1*1G/160/3L/5R/ CB_bg_0.3D_GEW_FR22	ATMN280B
AOD150-1Bw	EMEA	Italy	LU.S550B.077	AOD150-1Bw AOXPSTIT1 MC UMACw 1*1G/160/3L/5R/ CB_bg_0.3D_GEW_IT12	ATMN280B
AOD150-1Bw	EMEA	Middle East	LU.S550B.079	AOD150-1Bw EM AOXPSTME9 MC UMACw 1*1G/160/3L/5R/ CB_bg_0.3D_GEW_FR22	ATMN280B
AOD150-1Bw	EMEA	Middle East	LU.S550B.071	AOD150-1Bw EM AOXPSTME6 MC UMACw 1*1G/160/3L/5R/ CB_bg_0.3D_GEW_EN12	ATMN280B
AOD150-1Bw	EMEA	Middle East	LU.S550B.073	AOD150-1Bw EM AOXPSTME2 MC UMACw 1*1G/160/3L/5R/ CB_bg_0.3D_GEW_AR22	ATMN280B
AOD150-1Bw	EMEA	Middle East	LU.S550B.075	AOD150-1Bw EM AOXPSTME2 MC UMACw 1*1G/160/3L/5R/ CB_bg_0.3D_GEW_EN12	ATMN280B
AOD150-1Bw	EMEA	Middle East	LU.S550B.078	AOD150-1Bw EM AOXPSTME2 MC UMACw 1*1G/160/3L/5R/ CB_bg_0.3D_GEW_AR12	ATMN280B
AOD150-1Bw	EMEA	Eastern Europe	LU.S550B.065	AOD150-1Bw AOXPSTEU7 MC UMACw 1*1G/160/3L/5R/ CB_bg_0.3D_GEW_EN11	ATMN280B
AOD150-1Bw	EMEA	Poland	LU.S550B.066	AOD150-1Bw AOXPSTPL1 MC UMACw 1*1G/160/3L/5R/ CB_bg_0.3D_GEW_PL11	ATMN280B

Model	RO	Country	Acer P/N	Description	CPU
AOD150-1Bw	EMEA	UK	LU.S550B.069	AOD150-1Bw AOXPSTGB1 MC UMACw 1*1G/160/3L/5R/ CB_bg_0.3D_GEW_EN12	ATMN280B
AOD150-1Bw	EMEA	Switzerland	LU.S550B.067	AOD150-1Bw AOXPSTCH1 MC UMACw 1*1G/160/3L/5R/ CB_bg_0.3D_GEW_IT42	ATMN280B
AOD150-1Bw	EMEA	Eastern Europe	LU.S550B.063	AOD150-1Bw AOXPSTEU5 MC UMACw 1*1G/160/3L/5R/ CB_bg_0.3D_GEW_PL14	ATMN280B
AOD150-1Bw	EMEA	Eastern Europe	LU.S550B.064	AOD150-1Bw AOXPSTEU3 MC UMACw 1*1G/160/3L/5R/ CB_bg_0.3D_GEW_RU24	ATMN280B
AOD150-1Bw	EMEA	Ukraine	LU.S550B.068	AOD150-1Bw AOXPSTUK1 MC UMACw 1*1G/160/3L/5R/ CB_bg_0.3D_GEW_RU11	ATMN280B
AOD150-1Bw	EMEA	South Africa	LU.S550B.062	AOD150-1Bw EM AOXPSTZA2 MC UMACw 1*1G/160/BT/6L/5R/ CB_bg_0.3D_GEW_EN12	ATMN280B
AOD150-1Bw	EMEA	Denmark	LU.S550B.059	AOD150-1Bw AOXPSTDK1 MC UMACw 1*1G/160/BT/6L/5R/ CB_bg_0.3D_GEW_NO12	ATMN280B
AOD150-1Bw	EMEA	Austria	LU.S550B.052	AOD150-1Bw AOXPSTAT1 MC UMACw 1*1G/160/BT/6L/5R/ CB_bg_0.3D_GEW_DE11	ATMN280B
AOD150-1Bw	EMEA	South Africa	LU.S550B.058	AOD150-1Bw EM AOXPSTZA1 MC UMACw 1*1G/160/BT/6L/5R/ CB_bg_0.3D_GEW_FR22	ATMN280B
AOD150-1Bw	EMEA	France	LU.S550B.060	AOD150-1Bw AOXPSTFR1 MC UMACw 1*1G/160/BT/6L/5R/ CB_bg_0.3D_GEW_FR22	ATMN280B
AOD150-1Bw	EMEA	Eastern Europe	LU.S550B.049	AOD150-1Bw AOXPSTEU7 MC UMACw 1*1G/160/BT/6L/5R/ CB_bg_0.3D_GEW_ENR2	ATMN280B
AOD150-1Bw	EMEA	Eastern Europe	LU.S550B.045	AOD150-1Bw AOXPSTEU7 MC UMACw 1*1G/160/BT/6L/5R/ CB_bg_0.3D_GEW_SL11	ATMN280B
AOD150-1Bw	EMEA	Eastern Europe	LU.S550B.046	AOD150-1Bw AOXPSTEU7 MC UMACw 1*1G/160/BT/6L/5R/ CB_bg_0.3D_GEW_EN11	ATMN280B
AOD150-1Bw	EMEA	Finland	LU.S550B.042	AOD150-1Bw AOXPSTFI2 MC UMACw 1*1G/160/BT/6L/5R/ CB_bg_0.3D_GEW_FI41	ATMN280B
AOD150-1Bw	EMEA	Finland	LU.S550B.043	AOD150-1Bw AOXPSTFI2 MC UMACw 1*1G/160/BT/6L/5R/ CB_bg_0.3D_GEW_SV41	ATMN280B
AOD150-1Bw	EMEA	Eastern Europe	LU.S550B.051	AOD150-1Bw AOXPSTEU4 MC UMACw 1*1G/160/BT/6L/5R/ CB_bg_0.3D_GEW_FI13	ATMN280B
AOD150-1Bw	EMEA	Sweden	LU.S550B.048	AOD150-1Bw AOXPSTSE1 MC UMACw 1*1G/160/BT/6L/5R/ CB_bg_0.3D_GEW_FI13	ATMN280B
AOD150-1Bw	EMEA	Eastern Europe	LU.S550B.044	AOD150-1Bw AOXPSTEU5 MC UMACw 1*1G/160/BT/6L/5R/ CB_bg_0.3D_GEW_PL14	ATMN280B
AOD150-1Bw	EMEA	Eastern Europe	LU.S550B.050	AOD150-1Bw AOXPSTEU5 MC UMACw 1*1G/160/BT/6L/5R/ CB_bg_0.3D_GEW_RO12	ATMN280B

Model	RO	Country	Acer P/N	Description	CPU
AOD150-1Bw	EMEA	Eastern Europe	LU.S550B.047	AOD150-1Bw AOXPHEU3 MC UMACw 1*1G/160/BT/6L/5R/ CB_bg_0.3D_GEW_RU24	ATMN280B
AOD150-1Bw	EMEA	Greece	LU.S550B.036	AOD150-1Bw AOXPSTGR1 MC UMACw 1*1G/160/BT/6L/5R/ CB_bg_0.3D_GEW_EL32	ATMN280B
AOD150-1Bw	EMEA	Israel	LU.S550B.037	AOD150-1Bw AOXPSTIL1 MC UMACw 1*1G/160/BT/6L/5R/ CB_bg_0.3D_GEW_HE13	ATMN280B
AOD150-1Bw	EMEA	Finland	LU.S550B.038	AOD150-1Bw AOXPSTFI2 MC UMACw 1*1G/160/BT/6L/5R/ CB_bg_0.3D_GEW_FI31	ATMN280B
AOD150-1Bw	EMEA	Finland	LU.S550B.039	AOD150-1Bw AOXPSTFI2 MC UMACw 1*1G/160/BT/6L/5R/ CB_bg_0.3D_GEW_FI11	ATMN280B
AOD150-1Bw	EMEA	Portugal	LU.S550B.041	AOD150-1Bw AOXPSTPT1 MC UMACw 1*1G/160/BT/6L/5R/ CB_bg_0.3D_GEW_PT12	ATMN280B
AOD150-1Bw	EMEA	Middle East	LU.S550B.032	AOD150-1Bw EM AOXPSTME9 MC UMACw 1*1G/160/BT/6L/5R/ CB_bg_0.3D_GEW_FR22	ATMN280B
AOD150-1Bw	EMEA	Middle East	LU.S550B.033	AOD150-1Bw EM AOXPSTME2 MC UMACw 1*1G/160/BT/6L/5R/ CB_bg_0.3D_GEW_AR12	ATMN280B
AOD150-1Bw	EMEA	Turkey	LU.S550B.026	AOD150-1Bw AOXPSTTR1 MC UMACw 1*1G/160/BT/6L/5R/ CB_bg_0.3D_GEW_TR33	ATMN280B
AOD150-1Bw	EMEA	Ukraine	LU.S550B.023	AOD150-1Bw AOXPSTUK1 MC UMACw 1*1G/160/BT/6L/5R/ CB_bg_0.3D_GEW_RU11	ATMN280B
AOD150-1Bw	EMEA	Middle East	LU.S550B.029	AOD150-1Bw EM AOXPSTME3 MC UMACw 1*1G/160/BT/6L/5R/ CB_bg_0.3D_GEW_FR22	ATMN280B
AOD150-1Bw	EMEA	Switzerland	LU.S550B.024	AOD150-1Bw AOXPSTCH1 MC UMACw 1*1G/160/BT/6L/5R/ CB_bg_0.3D_GEW_IT42	ATMN280B
AOD150-1Bw	EMEA	Poland	LU.S550B.027	AOD150-1Bw AOXPSTPL1 MC UMACw 1*1G/160/BT/6L/5R/ CB_bg_0.3D_GEW_PL11	ATMN280B
AOD150-1Bw	EMEA	Middle East	LU.S550B.025	AOD150-1Bw EM AOXPSTME6 MC UMACw 1*1G/160/BT/6L/5R/ CB_bg_0.3D_GEW_EN12	ATMN280B
AOD150-1Bw	EMEA	Middle East	LU.S550B.028	AOD150-1Bw EM AOXPSTME2 MC UMACw 1*1G/160/BT/6L/5R/ CB_bg_0.3D_GEW_AR22	ATMN280B
AOD150-1Bw	EMEA	Middle East	LU.S550B.030	AOD150-1Bw EM AOXPSTME2 MC UMACw 1*1G/160/BT/6L/5R/ CB_bg_0.3D_GEW_EN12	ATMN280B
AOD150-1Bw	EMEA	Middle East	LU.S550B.031	AOD150-1Bw EM AOXPSTME4 MC UMACw 1*1G/160/BT/6L/5R/ CB_bg_0.3D_GEW_EN12	ATMN280B
AOD150-1Bw	EMEA	UK	LU.S550B.022	AOD150-1Bw AOXPSTGB1 MC UMACw 1*1G/160/BT/6L/5R/ CB_bg_0.3D_GEW_EN12	ATMN280B
AOD150-0Bw	PA	Canada	LU.S550B.007	AOD150-0Bw AOXPSTCA2 MC UMACw 1*1G/160/3L/ CB_bg_0.3D_GEW_FR31	ATMN270B

Model	RO	Country	Acer P/N	Description	CPU
AOD150-0Bw	CHINA	Hong Kong	LU.S550B.001	AOD150-0Bw AOXPSTHK2 MC UMACw 1*1G/160/3L/ CB_bg_0.3D_BAG_GEW_ZH31	ATMN270B
AOD150-0Bw	PA	USA	LU.S550B.008	AOD150-0Bw AOXPSTUS1 MC UMACw 1*1G/160/3L/ CB_bg_0.3D_GEW_EN31	ATMN270B
AOD150-0Bw	WW	WW	S2.S550B.002	AOD150-0Bw AOXPSTWW1 MC UMACw 1*1G/160/3L/ CB_bg_0.3D_GEW_EN11for Taiwan	ATMN270B
AOD150-0Bw	TWN	GCTWN	LU.S550B.006	AOD150-0Bw AOXPSTTW1 MC UMACw 1*1G/160/BT/3L/ CB_bg_0.3D_BAG_GEW_TC11	ATMN270B
AOD150-0Bw	WW	WW	S2.S550B.001	AOD150-0Bw AOXPSTWW1 MC UMACw 1*1G/160/BT/3L/ CB_bg_0.3D_GEW_EN11	ATMN270B
AOD150-0Bw	AAP	Japan	LU.S550B.020	AOD150-0Bw AOXPSTJP1 MC UMACw 1*1G/160/BT/3L/5R/ CB_bg_0.3D_BAG_GEW_JA11_Bw 73f	ATMN270B
AOD150-1BGb	AAP	Singapore	LU.S630B.014	AOD150-1BGb AOXPSTSG1 MC UMAGCb 1*1G/160/BT/6L/5R/ CB_bg_0.3D_3G_BAG_GEb_EN11	ATMN280B
AOD150-0BGb	AAP	Singapore	LU.S630B.013	AOD150-0BGb AOXPSTSG1 MC UMAGCb 1*1G/160/BT/6L/5R/ CB_bg_0.3D_3G_BAG_GEb_EN11	ATMN270B
AOD150-0BGb	PA	USA	LU.S630B.011	AOD150-0BGb AOXPSTUS1 MC UMAGCb 1*1G/160/3L/5R/ CB_bg_0.3D_3G_BAG_GEb_EN31	ATMN270B
AOD150-0BGb	PA	ACLA- Portuguese	LU.S630B.010	AOD150-0BGb EM AOXPSTXC2 MC UMAGCb 1*1G/160/3L/5R/ CB_bg_0.3D_3G_BAG_GEb_XC21	ATMN270B
AOD150-0BGb	PA	ACLA- Spanish	LU.S630B.008	AOD150-0BGb EM AOXPSTEA3 MC UMAGCb 1*1G/160/3L/5R/ CB_bg_0.3D_3G_BAG_GEb_ES21	ATMN270B
AOD150-0BGb	PA	Canada	LU.S630B.007	AOD150-0BGb AOXPSTCA2 MC UMAGCb 1*1G/160/6L2.6/5R/ CB_bg_0.3D_3G_BAG_GEb_FR31	ATMN270B
AOD150-0BGb	PA	Canada	LU.S630B.012	AOD150-0BGb AOXPSTCA2 MC UMAGCb 1*1G/160/3L/5R/ CB_bg_0.3D_3G_BAG_GEb_FR31	ATMN270B
AOD150-0BGb	PA	USA	LU.S630B.006	AOD150-0BGb AOXPSTUS1 MC UMAGCb 1*1G/160/6L2.6/5R/ CB_bg_0.3D_3G_BAG_GEb_EN31	ATMN270B
AOD150-0BGb	PA	ACLA- Portuguese	LU.S630B.005	AOD150-0BGb EM AOXPSTXC2 MC UMAGCb 1*1G/160/6L2.6/5R/ CB_bg_0.3D_3G_BAG_GEb_XC21	ATMN270B
AOD150-0BGb	PA	ACLA- Spanish	LU.S630B.009	AOD150-0BGb EM AOXPSTEA1 MC UMAGCb 1*1G/160/3L/5R/ CB_bg_0.3D_3G_BAG_GEb_ES21	ATMN270B
AOD150-0BGb	PA	ACLA- Spanish	LU.S630B.004	AOD150-0BGb EM AOXPSTEA1 MC UMAGCb 1*1G/160/6L2.6/5R/ CB_bg_0.3D_3G_BAG_GEb_ES21	ATMN270B
AOD150-0BGb	PA	ACLA- Spanish	LU.S630B.003	AOD150-0BGb EM AOXPSTEA3 MC UMAGCb 1*1G/160/6L2.6/5R/ CB_bg_0.3D_3G_BAG_GEb_ES21	ATMN270B

Model	RO	Country	Acer P/N	Description	CPU
AOD150-1BGb	AAP	Thailand	LU.S630B.001	AOD150-1BGb AOXPHSTTH1 MC UMAGCb 1*1G/160/BT/6L2.6/5R/ CB_bg_0.3D_3G_BAG_GEb_TH22	ATMN280B
AOD150-1BGb	AAP	Indonesia	LU.S630B.002	AOD150-1BGb AOXPHSTID1 MC UMAGCb 1*1G/160/BT/6L2.6/5R/ CB_bg_0.3D_3G_BAG_GEb_ID23	ATMN280B
AOD150-0BGk	AAP	Singapore	LU.S610B.007	AOD150-0BGk AOXPHSTSG1 MC UMAGCk 1*1G/160/BT/6L2.6/5R/ CB_bg_0.3D_3G_BAG_GEk_EN11	ATMN270B
AOD150-1BGk	AAP	Singapore	LU.S610B.006	AOD150-1BGk AOXPHSTSG1 MC UMAGCk 1*1G/160/BT/6L2.6/5R/ CB_bg_0.3D_3G_BAG_GEk_EN11	ATMN280B
AOD150-1BGk	EMEA	France	LU.S610B.005	AOD150-1BGk AOXPHSTFR1 MC UMAGCk 1*1G/160/BT/6L/5R/ CB_bg_0.3D_3G_BAG_GEk_FR22	ATMN280B
AOD150-1BGk	AAP	Thailand	LU.S610B.003	AOD150-1BGk AOXPHSTTH1 MC UMAGCk 1*1G/160/BT/6L2.6/5R/ CB_bg_0.3D_3G_BAG_GEk_TH22	ATMN280B
AOD150-1BGk	AAP	Indonesia	LU.S610B.004	AOD150-1BGk AOXPHSTID1 MC UMAGCk 1*1G/160/BT/6L2.6/5R/ CB_bg_0.3D_3G_BAG_GEk_ID23_ UNDP-1	ATMN280B
AOD150-1BGr	AAP	Singapore	LU.S590B.007	AOD150-1BGr AOXPHSTSG1 MC UMAGCr 1*1G/160/BT/6L/5R/ CB_bg_0.3D_3G_BAG_GEk_EN11	ATMN280B
AOD150-0BGr	AAP	Singapore	LU.S590B.006	AOD150-0BGr AOXPHSTSG1 MC UMAGCr 1*1G/160/BT/6L/5R/ CB_bg_0.3D_3G_BAG_GEk_EN11	ATMN270B
AOD150-1BGr	EMEA	France	LU.S590B.005	AOD150-1BGr AOXPHSTFR1 MC UMAGCr 1*1G/160/BT/6L/5R/ CB_bg_0.3D_3G_BAG_GEk_FR22	ATMN280B
AOD150-1BGr	AAP	Thailand	LU.S590B.003	AOD150-1BGr AOXPHSTTH1 MC UMAGCr 1*1G/160/BT/6L2.6/5R/ CB_bg_0.3D_3G_BAG_GEk_TH22	ATMN280B
AOD150-1BGr	AAP	Indonesia	LU.S590B.004	AOD150-1BGr AOXPHSTID1 MC UMAGCr 1*1G/160/BT/6L2.6/5R/ CB_bg_0.3D_3G_BAG_GEk_ID23	ATMN280B
AOD150-0BGw	WW	WW	S2.S580B.006	AOD150-0BGw AOXPHSTWW1 MC UMAGCw 1*1G/160/6L2.6/5R/ CB_bg_0.3D_3G_GEw_EN11GTM3 80E	ATMN270B
AOD150-0BGw	WW	WW	S2.S580B.005	AOD150-0BGw AOXPHSTWW1 MC UMAGCw 1*1G/160/6L2.6/5R/ CB_bg_0.3D_3G_GEw_EN11	ATMN270B
AOD150-1BGw	AAP	Singapore	LU.S580B.009	AOD150-1BGw AOXPHSTSG1 MC UMAGCw 1*1G/160/BT/6L/5R/ CB_bg_0.3D_3G_BAG_GEw_EN11	ATMN280B
AOD150-0BGw	AAP	Singapore	LU.S580B.008	AOD150-0BGw AOXPHSTSG1 MC UMAGCw 1*1G/160/BT/6L/5R/ CB_bg_0.3D_3G_BAG_GEw_EN11	ATMN270B
AOD150-1BGw	AAP	Indonesia	LU.S580B.005	AOD150-1BGw AOXPHSTID1 MC UMAGCw 1*1G/160/BT/6L/5R/ CB_bg_0.3D_3G_BAG_GEw_ID23	ATMN280B
AOD150-1BGw	EMEA	France	LU.S580B.007	AOD150-1BGw AOXPHSTFR1 MC UMAGCw 1*1G/160/BT/6L/5R/ CB_bg_0.3D_3G_BAG_GEw_FR22	ATMN280B

Model	RO	Country	Acer P/N	Description	CPU
AOD150-0BGw	AAP	Indonesia	LU.S580B.006	AOD150-0BGw AOXPSTID1 MC UMAGCw 1*1G/160/BT/6L/5R/ CB_bg_0.3D_3G_BAG_GEW_ID23	ATMN270B
AOD150-1BGw	AAP	Indonesia	LU.S580B.004	AOD150-1BGw AOXPSTID1 MC UMAGCw 1*1G/160/BT/6L2.6/5R/ CB_bg_0.3D_3G_BAG_GEW_ID23	ATMN280B
AOD150-0BGw	WW	WW	S2.S580B.002	AOD150-0BGw AOXPSTWW1 MC UMAGCw 1*1G/160/BT/6L2.6/ CB_bg_0.3D_3G_GEW_EN11for Taiwan	ATMN270B
AOD150-0BGw	WW	WW	S2.S580B.001	AOD150-0BGw AOXPSTWW1 MC UMAGCw 1*1G/160/BT/6L2.6/ CB_bg_0.3D_3G_GEW_EN11	ATMN270B
AOD150-1BGw	AAP	Thailand	LU.S580B.003	AOD150-1BGw AOXPSTTH1 MC UMAGCw 1*1G/160/BT/6L2.6/5R/ CB_bg_0.3D_3G_BAG_GEW_TH22	ATMN280B
AOD150-0BGw	WW	WW	S2.S580B.003	AOD150-0BGw AOXPSTWW1 MC UMAGCw 1*1G/160/BT/6L/ CB_bg_0.3D_3G_GEW_EN11for Gobi	ATMN270B
AOD150-0BGw	WW	WW	S2.S580B.004	AOD150-0BGw AOXPSTWW1 MC UMAGCw 1*1G/160/6L/ CB_bg_0.3D_3G_GEW_EN11for Gobi Taiwan	ATMN270B

Model	LCD	Memory 1	HDD 1(GB)	Card Reader	Wireless LAN	BT
AOD150-0Bb	NLED10.1WSV GAG	SO1GBI16	N160GB5.4KS	5 in 1-Build in	3rd WiFi BG	N
AOD150-0Bb	NLED10.1WSV GAG	SO1GBI16	N160GB5.4KS	5 in 1-Build in	3rd WiFi BG	N
AOD150-1Bb	NLED10.1WSV GAG	SO1GBI16	N160GB5.4KS	5 in 1-Build in	3rd WiFi BG	BT 2.0
AOD150-0Bb	NLED10.1WSV GAG	SO1GBI16	N160GB5.4KS	5 in 1-Build in	3rd WiFi BG	BT 2.0
AOD150-1Bb	NLED10.1WSV GAG	SO1GBI16	N160GB5.4KS	5 in 1-Build in	3rd WiFi BG	BT 2.0
AOD150-0Bb	NLED10.1WSV GAG	SO1GBI16	N160GB5.4KS	5 in 1-Build in	3rd WiFi BG	N
AOD150-0Bb	NLED10.1WSV GAG	SO1GBI16	N160GB5.4KS	5 in 1-Build in	3rd WiFi BG	N
AOD150-0Bb	NLED10.1WSV GAG	SO1GBI16	N160GB5.4KS	5 in 1-Build in	3rd WiFi BG	N
AOD150-0Bb	NLED10.1WSV GAG	SO1GBI16	N160GB5.4KS	5 in 1-Build in	3rd WiFi BG	N
AOD150-0Bb	NLED10.1WSV GAG	SO1GBI16	N160GB5.4KS	5 in 1-Build in	3rd WiFi BG	N
AOD150-1Bb	NLED10.1WSV GAG	SO1GBI16	N160GB5.4KS	5 in 1-Build in	3rd WiFi BG	N
AOD150-1Bb	NLED10.1WSV GAG	SO1GBI16	N160GB5.4KS	5 in 1-Build in	3rd WiFi BG	N
AOD150-1Bb	NLED10.1WSV GAG	SO1GBI16	N160GB5.4KS	5 in 1-Build in	3rd WiFi BG	N
AOD150-1Bb	NLED10.1WSV GAG	SO1GBI16	N160GB5.4KS	5 in 1-Build in	3rd WiFi BG	N
AOD150-1Bb	NLED10.1WSV GAG	SO1GBI16	N160GB5.4KS	5 in 1-Build in	3rd WiFi BG	N
AOD150-1Bb	NLED10.1WSV GAG	SO1GBI16	N160GB5.4KS	5 in 1-Build in	3rd WiFi BG	N

Model	LCD	Memory 1	HDD 1(GB)	Card Reader	Wireless LAN	BT
AOD150-0Bb	NLED10.1WSV GAG	SO1GBII6	N160GB5.4KS	5 in 1-Build in	3rd WiFi BG	BT 2.0
AOD150-0Bb	NLED10.1WSV GAG	SO1GBII6	N160GB5.4KS	5 in 1-Build in	3rd WiFi BG	N
AOD150-0Bb	NLED10.1WSV GAG	SO1GBII6	N160GB5.4KS	5 in 1-Build in	3rd WiFi BG	N
AOD150-0Bb	NLED10.1WSV GAG	SO1GBII6	N160GB5.4KS	5 in 1-Build in	3rd WiFi BG	N
AOD150-1Bb	NLED10.1WSV GAG	SO1GBII6	N160GB5.4KS	5 in 1-Build in	3rd WiFi BG	N
AOD150-1Bb	NLED10.1WSV GAG	SO1GBII6	N160GB5.4KS	5 in 1-Build in	3rd WiFi BG	N
AOD150-0Bb	NLED10.1WSV GAG	SO1GBII6	N160GB5.4KS	5 in 1-Build in	3rd WiFi BG	N
AOD150-0Bb	NLED10.1WSV GAG	SO1GBII6	N160GB5.4KS	5 in 1-Build in	3rd WiFi BG	N
AOD150-0Bb	NLED10.1WSV GAG	SO1GBII6	N160GB5.4KS	5 in 1-Build in	3rd WiFi BG	N
AOD150-0Bb	NLED10.1WSV GAG	SO1GBII6	N160GB5.4KS	5 in 1-Build in	3rd WiFi BG	N
AOD150-0Bb	NLED10.1WSV GAG	SO1GBII6	N160GB5.4KS	5 in 1-Build in	3rd WiFi BG	N
AOD150-0Bb	NLED10.1WSV GAG	SO1GBII6	N160GB5.4KS	5 in 1-Build in	3rd WiFi BG	N
AOD150-0Bb	NLED10.1WSV GAG	SO1GBII6	N160GB5.4KS	5 in 1-Build in	3rd WiFi BG	N
AOD150-0Bb	NLED10.1WSV GAG	SO1GBII6	N160GB5.4KS	5 in 1-Build in	3rd WiFi BG	N
AOD150-0Bb	NLED10.1WSV GAG	SO1GBII6	N160GB5.4KS	5 in 1-Build in	3rd WiFi BG	N
AOD150-0Bb	NLED10.1WSV GAG	SO1GBII6	N160GB5.4KS	5 in 1-Build in	3rd WiFi BG	N
AOD150-0Bb	NLED10.1WSV GAG	SO1GBII6	N160GB5.4KS	5 in 1-Build in	3rd WiFi BG	N
AOD150-1Bb	NLED10.1WSV GAG	SO1GBII6	N160GB5.4KS	5 in 1-Build in	3rd WiFi BG	BT 2.0
AOD150-0Bb	NLED10.1WSV GAG	SO1GBII6	N160GB5.4KS	5 in 1-Build in	3rd WiFi BG	BT 2.0
AOD150-0Bb	NLED10.1WSV GAG	SO1GBII6	N160GB5.4KS	5 in 1-Build in	3rd WiFi BG	N
AOD150-0Bb	NLED10.1WSV GAG	SO1GBII6	N160GB5.4KS	5 in 1-Build in	3rd WiFi BG	N
AOD150-0Bb	NLED10.1WSV GAG	SO1GBII6	N160GB5.4KS	5 in 1-Build in	3rd WiFi BG	BT 2.0
AOD150-1Bk	NLED10.1WSV GAG	SO1GBII6	N160GB5.4KS	5 in 1-Build in	3rd WiFi BG	BT 2.0
AOD150-1Bk	NLED10.1WSV GAG	SO1GBII6	N160GB5.4KS	5 in 1-Build in	3rd WiFi BG	BT 2.0
AOD150-0Bk	NLED10.1WSV GAG	SO1GBII6	N160GB5.4KS	5 in 1-Build in	3rd WiFi BG	BT 2.0
AOD150-1Bk	NLED10.1WSV GAG	SO1GBII6	N160GB5.4KS	5 in 1-Build in	3rd WiFi BG	BT 2.0
AOD150-0Bk	NLED10.1WSV GAG	SO1GBII6	N160GB5.4KS	5 in 1-Build in	3rd WiFi BG	N
AOD150-0Bk	NLED10.1WSV GAG	SO1GBII6	N160GB5.4KS	5 in 1-Build in	3rd WiFi BG	BT 2.0
AOD150-1Bk	NLED10.1WSV GAG	SO1GBII6	N160GB5.4KS	5 in 1-Build in	3rd WiFi BG	N

Model	LCD	Memory 1	HDD 1(GB)	Card Reader	Wireless LAN	BT
AOD150-1Bk	NLED10.1WSV GAG	SO1GBI16	N160GB5.4KS	5 in 1-Build in	3rd WiFi BG	BT 2.0
AOD150-0Bk	NLED10.1WSV GAG	SO1GBI16	N160GB5.4KS	5 in 1-Build in	3rd WiFi BG	BT 2.0
AOD150-1Bk	NLED10.1WSV GAG	SO1GBI16	N160GB5.4KS	5 in 1-Build in	3rd WiFi BG	N
AOD150-1Bk	NLED10.1WSV GAG	SO1GBI16	N160GB5.4KS	5 in 1-Build in	3rd WiFi BG	N
AOD150-1Bk	NLED10.1WSV GAG	SO1GBI16	N160GB5.4KS	5 in 1-Build in	3rd WiFi BG	N
AOD150-1Bk	NLED10.1WSV GAG	SO1GBI16	N160GB5.4KS	5 in 1-Build in	3rd WiFi BG	N
AOD150-1Bk	NLED10.1WSV GAG	SO1GBI16	N160GB5.4KS	5 in 1-Build in	3rd WiFi BG	N
AOD150-1Bk	NLED10.1WSV GAG	SO1GBI16	N160GB5.4KS	5 in 1-Build in	3rd WiFi BG	N
AOD150-1Bk	NLED10.1WSV GAG	SO1GBI16	N160GB5.4KS	5 in 1-Build in	3rd WiFi BG	N
AOD150-1Bk	NLED10.1WSV GAG	SO1GBI16	N160GB5.4KS	5 in 1-Build in	3rd WiFi BG	N
AOD150-1Bk	NLED10.1WSV GAG	SO1GBI16	N160GB5.4KS	5 in 1-Build in	3rd WiFi BG	N
AOD150-1Bk	NLED10.1WSV GAG	SO1GBI16	N160GB5.4KS	5 in 1-Build in	3rd WiFi BG	N
AOD150-1Bk	NLED10.1WSV GAG	SO1GBI16	N160GB5.4KS	5 in 1-Build in	3rd WiFi BG	N
AOD150-1Bk	NLED10.1WSV GAG	SO1GBI16	N160GB5.4KS	5 in 1-Build in	3rd WiFi BG	N
AOD150-0Bk	NLED10.1WSV GAG	SO1GBI16	N160GB5.4KS	5 in 1-Build in	3rd WiFi BG	N
AOD150-0Bk	NLED10.1WSV GAG	SO1GBI16	N160GB5.4KS	5 in 1-Build in	3rd WiFi BG	N
AOD150-0Bk	NLED10.1WSV GAG	SO1GBI16	N160GB5.4KS	5 in 1-Build in	3rd WiFi BG	N
AOD150-0Bk	NLED10.1WSV GAG	SO1GBI16	N160GB5.4KS	5 in 1-Build in	3rd WiFi BG	N
AOD150-0Bk	NLED10.1WSV GAG	SO1GBI16	N160GB5.4KS	5 in 1-Build in	3rd WiFi BG	N
AOD150-0Bk	NLED10.1WSV GAG	SO1GBI16	N160GB5.4KS	5 in 1-Build in	3rd WiFi BG	N
AOD150-0Bk	NLED10.1WSV GAG	SO1GBI16	N160GB5.4KS	5 in 1-Build in	3rd WiFi BG	N
AOD150-0Bk	NLED10.1WSV GAG	SO1GBI16	N160GB5.4KS	5 in 1-Build in	3rd WiFi BG	N
AOD150-0Bk	NLED10.1WSV GAG	SO1GBI16	N160GB5.4KS	5 in 1-Build in	3rd WiFi BG	BT 2.0
AOD150-0Bk	NLED10.1WSV GAG	SO1GBI16	N160GB5.4KS	5 in 1-Build in	3rd WiFi BG	BT 2.0
AOD150-1Bk	NLED10.1WSV GAG	SO1GBI16	N160GB5.4KS	5 in 1-Build in	3rd WiFi BG	BT 2.0
AOD150-0Bk	NLED10.1WSV GAG	SO1GBI16	N160GB5.4KS	5 in 1-Build in	3rd WiFi BG	BT 2.0
AOD150-0Bk	NLED10.1WSV GAG	SO1GBI16	N160GB5.4KS	5 in 1-Build in	3rd WiFi BG	BT 2.0
AOD150-1Bk	NLED10.1WSV GAG	SO1GBI16	N160GB5.4KS	5 in 1-Build in	3rd WiFi BG	BT 2.0
AOD150-0Bk	NLED10.1WSV GAG	SO1GBI16	N160GB5.4KS	5 in 1-Build in	3rd WiFi BG	N
AOD150-1Bk	NLED10.1WSV GAG	SO1GBI16	N160GB5.4KS	5 in 1-Build in	3rd WiFi BG	BT 2.0

Model	LCD	Memory 1	HDD 1(GB)	Card Reader	Wireless LAN	BT
AOD150-0Bk	NLED10.1WSV GAG	SO1GBII6	N160GB5.4KS	5 in 1-Build in	3rd WiFi BG	BT 2.0
AOD150-0Bk	NLED10.1WSV GAG	SO1GBII6	N160GB5.4KS	5 in 1-Build in	3rd WiFi BG	BT 2.0
AOD150-1Bk	NLED10.1WSV GAG	SO1GBII6	N160GB5.4KS	5 in 1-Build in	3rd WiFi BG	BT 2.0
AOD150-0Bk	NLED10.1WSV GAG	SO1GBII6	N160GB5.4KS	5 in 1-Build in	3rd WiFi BG	N
AOD150-1Bk	NLED10.1WSV GAG	SO1GBII6	N160GB5.4KS	5 in 1-Build in	3rd WiFi BG	BT 2.0
AOD150-1Bk	NLED10.1WSV GAG	SO1GBII6	N160GB5.4KS	5 in 1-Build in	3rd WiFi BG	N
AOD150-0Bk	NLED10.1WSV GAG	SO1GBII6	N160GB5.4KS	5 in 1-Build in	3rd WiFi BG	BT 2.0
AOD150-1Bk	NLED10.1WSV GAG	SO1GBII6	N160GB5.4KS	5 in 1-Build in	3rd WiFi BG	BT 2.0
AOD150-1Bk	NLED10.1WSV GAG	SO1GBII6	N160GB5.4KS	5 in 1-Build in	3rd WiFi BG	BT 2.0
AOD150-0Bk	NLED10.1WSV GAG	SO1GBII6	N160GB5.4KS	5 in 1-Build in	3rd WiFi BG	BT 2.0
AOD150-0Bk	NLED10.1WSV GAG	SO512MBII6	N160GB5.4KS	5 in 1-Build in	3rd WiFi BG	BT 2.0
AOD150-0Bk	NLED10.1WSV GAG	SO1GBII6	N160GB5.4KS	5 in 1-Build in	3rd WiFi BG	N
AOD150-1Bk	NLED10.1WSV GAG	SO1GBII6	N160GB5.4KS	5 in 1-Build in	3rd WiFi BG	BT 2.0
AOD150-1Bk	NLED10.1WSV GAG	SO1GBII6	N160GB5.4KS	5 in 1-Build in	3rd WiFi BG	BT 2.0
AOD150-0Bk	NLED10.1WSV GAG	SO1GBII6	N160GB5.4KS	5 in 1-Build in	3rd WiFi BG	BT 2.0
AOD150-1Bk	NLED10.1WSV GAG	SO1GBII6	N160GB5.4KS	5 in 1-Build in	3rd WiFi BG	BT 2.0
AOD150-1Bk	NLED10.1WSV GAG	SO1GBII6	N160GB5.4KS	5 in 1-Build in	3rd WiFi BG	BT 2.0
AOD150-0Bk	NLED10.1WSV GAG	SO1GBII6	N160GB5.4KS	5 in 1-Build in	3rd WiFi BG	N
AOD150-0Bk	NLED10.1WSV GAG	SO1GBII6	N160GB5.4KS	5 in 1-Build in	3rd WiFi BG	N
AOD150-0Bk	NLED10.1WSV GAG	SO1GBII6	N160GB5.4KS	5 in 1-Build in	3rd WiFi BG	N
AOD150-0Bk	NLED10.1WSV GAG	SO1GBII6	N160GB5.4KS	5 in 1-Build in	3rd WiFi BG	N
AOD150-0Bk	NLED10.1WSV GAG	SO1GBII6	N160GB5.4KS	5 in 1-Build in	3rd WiFi BG	N
AOD150-1Bk	NLED10.1WSV GAG	SO1GBII6	N160GB5.4KS	5 in 1-Build in	3rd WiFi BG	N
AOD150-1Bk	NLED10.1WSV GAG	SO1GBII6	N160GB5.4KS	5 in 1-Build in	3rd WiFi BG	N
AOD150-1Bk	NLED10.1WSV GAG	SO1GBII6	N160GB5.4KS	5 in 1-Build in	3rd WiFi BG	N
AOD150-1Bk	NLED10.1WSV GAG	SO1GBII6	N160GB5.4KS	5 in 1-Build in	3rd WiFi BG	N
AOD150-1Bk	NLED10.1WSV GAG	SO1GBII6	N160GB5.4KS	5 in 1-Build in	3rd WiFi BG	N
AOD150-1Bk	NLED10.1WSV GAG	SO1GBII6	N160GB5.4KS	5 in 1-Build in	3rd WiFi BG	N
AOD150-1Bk	NLED10.1WSV GAG	SO1GBII6	N160GB5.4KS	5 in 1-Build in	3rd WiFi BG	N
AOD150-1Bk	NLED10.1WSV GAG	SO1GBII6	N160GB5.4KS	5 in 1-Build in	3rd WiFi BG	N

Model	LCD	Memory 1	HDD 1(GB)	Card Reader	Wireless LAN	BT
AOD150-1Bk	NLED10.1WSV GAG	SO1GBI16	N160GB5.4KS	5 in 1-Build in	3rd WiFi BG	N
AOD150-1Bk	NLED10.1WSV GAG	SO1GBI16	N160GB5.4KS	5 in 1-Build in	3rd WiFi BG	N
AOD150-1Bk	NLED10.1WSV GAG	SO1GBI16	N160GB5.4KS	5 in 1-Build in	3rd WiFi BG	N
AOD150-1Bk	NLED10.1WSV GAG	SO1GBI16	N160GB5.4KS	5 in 1-Build in	3rd WiFi BG	N
AOD150-1Bk	NLED10.1WSV GAG	SO1GBI16	N160GB5.4KS	5 in 1-Build in	3rd WiFi BG	N
AOD150-1Bk	NLED10.1WSV GAG	SO1GBI16	N160GB5.4KS	5 in 1-Build in	3rd WiFi BG	N
AOD150-1Bk	NLED10.1WSV GAG	SO1GBI16	N160GB5.4KS	5 in 1-Build in	3rd WiFi BG	N
AOD150-1Bk	NLED10.1WSV GAG	SO1GBI16	N160GB5.4KS	5 in 1-Build in	3rd WiFi BG	N
AOD150-1Bk	NLED10.1WSV GAG	SO1GBI16	N160GB5.4KS	5 in 1-Build in	3rd WiFi BG	N
AOD150-1Bk	NLED10.1WSV GAG	SO1GBI16	N160GB5.4KS	5 in 1-Build in	3rd WiFi BG	N
AOD150-1Bk	NLED10.1WSV GAG	SO1GBI16	N160GB5.4KS	5 in 1-Build in	3rd WiFi BG	N
AOD150-1Bk	NLED10.1WSV GAG	SO1GBI16	N160GB5.4KS	5 in 1-Build in	3rd WiFi BG	N
AOD150-1Bk	NLED10.1WSV GAG	SO1GBI16	N160GB5.4KS	5 in 1-Build in	3rd WiFi BG	N
AOD150-1Bk	NLED10.1WSV GAG	SO1GBI16	N160GB5.4KS	5 in 1-Build in	3rd WiFi BG	N
AOD150-1Bk	NLED10.1WSV GAG	SO1GBI16	N160GB5.4KS	5 in 1-Build in	3rd WiFi BG	N
AOD150-1Bk	NLED10.1WSV GAG	SO1GBI16	N160GB5.4KS	5 in 1-Build in	3rd WiFi BG	N
AOD150-1Bk	NLED10.1WSV GAG	SO1GBI16	N160GB5.4KS	5 in 1-Build in	3rd WiFi BG	N
AOD150-1Bk	NLED10.1WSV GAG	SO1GBI16	N160GB5.4KS	5 in 1-Build in	3rd WiFi BG	N
AOD150-1Bk	NLED10.1WSV GAG	SO1GBI16	N160GB5.4KS	5 in 1-Build in	3rd WiFi BG	N
AOD150-1Bk	NLED10.1WSV GAG	SO1GBI16	N160GB5.4KS	5 in 1-Build in	3rd WiFi BG	N
AOD150-1Bk	NLED10.1WSV GAG	SO1GBI16	N160GB5.4KS	5 in 1-Build in	3rd WiFi BG	N
AOD150-1Bk	NLED10.1WSV GAG	SO1GBI16	N160GB5.4KS	5 in 1-Build in	3rd WiFi BG	N
AOD150-1Bk	NLED10.1WSV GAG	SO1GBI16	N160GB5.4KS	5 in 1-Build in	3rd WiFi BG	N
AOD150-1Bk	NLED10.1WSV GAG	SO1GBI16	N160GB5.4KS	5 in 1-Build in	3rd WiFi BG	N
AOD150-1Bk	NLED10.1WSV GAG	SO1GBI16	N160GB5.4KS	5 in 1-Build in	3rd WiFi BG	N
AOD150-1Bk	NLED10.1WSV GAG	SO1GBI16	N160GB5.4KS	5 in 1-Build in	3rd WiFi BG	N

Model	LCD	Memory 1	HDD 1(GB)	Card Reader	Wireless LAN	BT
AOD150-0Bk	NLED10.1WSV GAG	SO1GBII6	N160GB5.4KS	5 in 1-Build in	3rd WiFi BG	BT 2.0
AOD150-0Bk	NLED10.1WSV GAG	SO1GBII6	N160GB5.4KS	5 in 1-Build in	3rd WiFi BG	BT 2.0
AOD150-0Bk	NLED10.1WSV GAG	SO1GBII6	N160GB5.4KS	5 in 1-Build in	3rd WiFi BG	N
AOD150-0Bk	NLED10.1WSV GAG	SO1GBII6	N160GB5.4KS	5 in 1-Build in	3rd WiFi BG	N
AOD150-0Bk	NLED10.1WSV GAG	SO1GBII6	N160GB5.4KS	5 in 1-Build in	3rd WiFi BG	N
AOD150-0Bk	NLED10.1WSV GAG	SO1GBII6	N160GB5.4KS	5 in 1-Build in	3rd WiFi BG	N
AOD150-0Bk	NLED10.1WSV GAG	SO1GBII6	N160GB5.4KS	5 in 1-Build in	3rd WiFi BG	N
AOD150-0Bk	NLED10.1WSV GAG	SO1GBII6	N160GB5.4KS	5 in 1-Build in	3rd WiFi BG	N
AOD150-0Bk	NLED10.1WSV GAG	SO1GBII6	N160GB5.4KS	5 in 1-Build in	3rd WiFi BG	BT 2.0
AOD150-1Bk	NLED10.1WSV GAG	SO1GBII6	N160GB5.4KS	5 in 1-Build in	3rd WiFi BG	BT 2.0
AOD150-1Br	NLED10.1WSV GAG	SO1GBII6	N160GB5.4KS	5 in 1-Build in	3rd WiFi BG	BT 2.0
AOD150-1Br	NLED10.1WSV GAG	SO1GBII6	N160GB5.4KS	5 in 1-Build in	3rd WiFi BG	BT 2.0
AOD150-0Br	NLED10.1WSV GAG	SO1GBII6	N160GB5.4KS	5 in 1-Build in	3rd WiFi BG	N
AOD150-0Br	NLED10.1WSV GAG	SO1GBII6	N160GB5.4KS	5 in 1-Build in	3rd WiFi BG	BT 2.0
AOD150-1Br	NLED10.1WSV GAG	SO1GBII6	N160GB5.4KS	5 in 1-Build in	3rd WiFi BG	BT 2.0
AOD150-0Br	NLED10.1WSV GAG	SO1GBII6	N160GB5.4KS	5 in 1-Build in	3rd WiFi BG	BT 2.0
AOD150-0Br	NLED10.1WSV GAG	SO1GBII6	N160GB5.4KS	5 in 1-Build in	3rd WiFi BG	BT 2.0
AOD150-1Br	NLED10.1WSV GAG	SO1GBII6	N160GB5.4KS	5 in 1-Build in	3rd WiFi BG	N
AOD150-1Br	NLED10.1WSV GAG	SO1GBII6	N160GB5.4KS	5 in 1-Build in	3rd WiFi BG	BT 2.0
AOD150-0Br	NLED10.1WSV GAG	SO1GBII6	N160GB5.4KS	5 in 1-Build in	3rd WiFi BG	N
AOD150-0Br	NLED10.1WSV GAG	SO1GBII6	N160GB5.4KS	5 in 1-Build in	3rd WiFi BG	N
AOD150-0Br	NLED10.1WSV GAG	SO1GBII6	N160GB5.4KS	5 in 1-Build in	3rd WiFi BG	N
AOD150-0Br	NLED10.1WSV GAG	SO1GBII6	N160GB5.4KS	5 in 1-Build in	3rd WiFi BG	N
AOD150-0Br	NLED10.1WSV GAG	SO1GBII6	N160GB5.4KS	5 in 1-Build in	3rd WiFi BG	N
AOD150-0Br	NLED10.1WSV GAG	SO1GBII6	N160GB5.4KS	5 in 1-Build in	3rd WiFi BG	N
AOD150-0Br	NLED10.1WSV GAG	SO1GBII6	N160GB5.4KS	5 in 1-Build in	3rd WiFi BG	BT 2.0
AOD150-0Br	NLED10.1WSV GAG	SO1GBII6	N160GB5.4KS	5 in 1-Build in	3rd WiFi BG	BT 2.0

Model	LCD	Memory 1	HDD 1(GB)	Card Reader	Wireless LAN	BT
AOD150-0Br	NLED10.1WSV GAG	SO1GBI16	N160GB5.4KS	5 in 1-Build in	3rd WiFi BG	BT 2.0
AOD150-0Br	NLED10.1WSV GAG	SO1GBI16	N160GB5.4KS	5 in 1-Build in	3rd WiFi BG	BT 2.0
AOD150-0Br	NLED10.1WSV GAG	SO1GBI16	N160GB5.4KS	5 in 1-Build in	3rd WiFi BG	BT 2.0
AOD150-0Br	NLED10.1WSV GAG	SO1GBI16	N160GB5.4KS	5 in 1-Build in	3rd WiFi BG	BT 2.0
AOD150-0Br	NLED10.1WSV GAG	SO1GBI16	N160GB5.4KS	5 in 1-Build in	3rd WiFi BG	BT 2.0
AOD150-0Br	NLED10.1WSV GAG	SO1GBI16	N160GB5.4KS	5 in 1-Build in	3rd WiFi BG	BT 2.0
AOD150-0Br	NLED10.1WSV GAG	SO1GBI16	N160GB5.4KS	5 in 1-Build in	3rd WiFi BG	BT 2.0
AOD150-0Br	NLED10.1WSV GAG	SO1GBI16	N160GB5.4KS	5 in 1-Build in	3rd WiFi BG	N
AOD150-0Br	NLED10.1WSV GAG	SO1GBI16	N160GB5.4KS	5 in 1-Build in	3rd WiFi BG	BT 2.0
AOD150-1Br	NLED10.1WSV GAG	SO1GBI16	N160GB5.4KS	5 in 1-Build in	3rd WiFi BG	BT 2.0
AOD150-0Br	NLED10.1WSV GAG	SO1GBI16	N160GB5.4KS	5 in 1-Build in	3rd WiFi BG	BT 2.0
AOD150-0Br	NLED10.1WSV GAG	SO1GBI16	N160GB5.4KS	5 in 1-Build in	3rd WiFi BG	BT 2.0
AOD150-0Br	NLED10.1WSV GAG	SO1GBI16	N160GB5.4KS	5 in 1-Build in	3rd WiFi BG	BT 2.0
AOD150-0Br	NLED10.1WSV GAG	SO1GBI16	N160GB5.4KS	5 in 1-Build in	3rd WiFi BG	BT 2.0
AOD150-0Br	NLED10.1WSV GAG	SO1GBI16	N160GB5.4KS	5 in 1-Build in	3rd WiFi BG	BT 2.0
AOD150-1Br	NLED10.1WSV GAG	SO1GBI16	N160GB5.4KS	5 in 1-Build in	3rd WiFi BG	BT 2.0
AOD150-0Br	NLED10.1WSV GAG	SO1GBI16	N160GB5.4KS	5 in 1-Build in	3rd WiFi BG	N
AOD150-0Br	NLED10.1WSV GAG	SO1GBI16	N160GB5.4KS	5 in 1-Build in	3rd WiFi BG	N
AOD150-0Br	NLED10.1WSV GAG	SO1GBI16	N160GB5.4KS	5 in 1-Build in	3rd WiFi BG	N
AOD150-0Br	NLED10.1WSV GAG	SO1GBI16	N160GB5.4KS	5 in 1-Build in	3rd WiFi BG	N
AOD150-0Br	NLED10.1WSV GAG	SO1GBI16	N160GB5.4KS	5 in 1-Build in	3rd WiFi BG	N
AOD150-0Br	NLED10.1WSV GAG	SO1GBI16	N160GB5.4KS	5 in 1-Build in	3rd WiFi BG	N
AOD150-1Br	NLED10.1WSV GAG	SO1GBI16	N160GB5.4KS	5 in 1-Build in	3rd WiFi BG	N
AOD150-1Br	NLED10.1WSV GAG	SO1GBI16	N160GB5.4KS	5 in 1-Build in	3rd WiFi BG	N
AOD150-1Br	NLED10.1WSV GAG	SO1GBI16	N160GB5.4KS	5 in 1-Build in	3rd WiFi BG	N
AOD150-1Br	NLED10.1WSV GAG	SO1GBI16	N160GB5.4KS	5 in 1-Build in	3rd WiFi BG	N
AOD150-1Br	NLED10.1WSV GAG	SO1GBI16	N160GB5.4KS	5 in 1-Build in	3rd WiFi BG	N
AOD150-1Br	NLED10.1WSV GAG	SO1GBI16	N160GB5.4KS	5 in 1-Build in	3rd WiFi BG	N

Model	LCD	Memory 1	HDD 1(GB)	Card Reader	Wireless LAN	BT
AOD150-1Br	NLED10.1WSV GAG	SO1GBII6	N160GB5.4KS	5 in 1-Build in	3rd WiFi BG	N
AOD150-1Br	NLED10.1WSV GAG	SO1GBII6	N160GB5.4KS	5 in 1-Build in	3rd WiFi BG	N
AOD150-1Br	NLED10.1WSV GAG	SO1GBII6	N160GB5.4KS	5 in 1-Build in	3rd WiFi BG	N
AOD150-1Br	NLED10.1WSV GAG	SO1GBII6	N160GB5.4KS	5 in 1-Build in	3rd WiFi BG	N
AOD150-1Br	NLED10.1WSV GAG	SO1GBII6	N160GB5.4KS	5 in 1-Build in	3rd WiFi BG	N
AOD150-1Br	NLED10.1WSV GAG	SO1GBII6	N160GB5.4KS	5 in 1-Build in	3rd WiFi BG	N
AOD150-1Br	NLED10.1WSV GAG	SO1GBII6	N160GB5.4KS	5 in 1-Build in	3rd WiFi BG	N
AOD150-1Br	NLED10.1WSV GAG	SO1GBII6	N160GB5.4KS	5 in 1-Build in	3rd WiFi BG	N
AOD150-1Br	NLED10.1WSV GAG	SO1GBII6	N160GB5.4KS	5 in 1-Build in	3rd WiFi BG	N
AOD150-1Br	NLED10.1WSV GAG	SO1GBII6	N160GB5.4KS	5 in 1-Build in	3rd WiFi BG	N
AOD150-1Br	NLED10.1WSV GAG	SO1GBII6	N160GB5.4KS	5 in 1-Build in	3rd WiFi BG	N
AOD150-1Br	NLED10.1WSV GAG	SO1GBII6	N160GB5.4KS	5 in 1-Build in	3rd WiFi BG	N
AOD150-1Br	NLED10.1WSV GAG	SO1GBII6	N160GB5.4KS	5 in 1-Build in	3rd WiFi BG	N
AOD150-1Br	NLED10.1WSV GAG	SO1GBII6	N160GB5.4KS	5 in 1-Build in	3rd WiFi BG	N
AOD150-1Br	NLED10.1WSV GAG	SO1GBII6	N160GB5.4KS	5 in 1-Build in	3rd WiFi BG	N
AOD150-1Br	NLED10.1WSV GAG	SO1GBII6	N160GB5.4KS	5 in 1-Build in	3rd WiFi BG	N
AOD150-1Br	NLED10.1WSV GAG	SO1GBII6	N160GB5.4KS	5 in 1-Build in	3rd WiFi BG	N
AOD150-1Br	NLED10.1WSV GAG	SO1GBII6	N160GB5.4KS	5 in 1-Build in	3rd WiFi BG	N
AOD150-1Br	NLED10.1WSV GAG	SO1GBII6	N160GB5.4KS	5 in 1-Build in	3rd WiFi BG	N
AOD150-1Br	NLED10.1WSV GAG	SO1GBII6	N160GB5.4KS	5 in 1-Build in	3rd WiFi BG	N
AOD150-1Br	NLED10.1WSV GAG	SO1GBII6	N160GB5.4KS	5 in 1-Build in	3rd WiFi BG	N
AOD150-1Br	NLED10.1WSV GAG	SO1GBII6	N160GB5.4KS	5 in 1-Build in	3rd WiFi BG	N
AOD150-1Br	NLED10.1WSV GAG	SO1GBII6	N160GB5.4KS	5 in 1-Build in	3rd WiFi BG	N

Model	LCD	Memory 1	HDD 1(GB)	Card Reader	Wireless LAN	BT
AOD150-1Br	NLED10.1WSV GAG	SO1GBI16	N160GB5.4KS	5 in 1-Build in	3rd WiFi BG	BT 2.0
AOD150-1Br	NLED10.1WSV GAG	SO1GBI16	N160GB5.4KS	5 in 1-Build in	3rd WiFi BG	BT 2.0
AOD150-1Br	NLED10.1WSV GAG	SO1GBI16	N160GB5.4KS	5 in 1-Build in	3rd WiFi BG	BT 2.0
AOD150-1Br	NLED10.1WSV GAG	SO1GBI16	N160GB5.4KS	5 in 1-Build in	3rd WiFi BG	BT 2.0
AOD150-1Br	NLED10.1WSV GAG	SO1GBI16	N160GB5.4KS	5 in 1-Build in	3rd WiFi BG	BT 2.0
AOD150-1Br	NLED10.1WSV GAG	SO1GBI16	N160GB5.4KS	5 in 1-Build in	3rd WiFi BG	BT 2.0
AOD150-1Br	NLED10.1WSV GAG	SO1GBI16	N160GB5.4KS	5 in 1-Build in	3rd WiFi BG	BT 2.0
AOD150-1Br	NLED10.1WSV GAG	SO1GBI16	N160GB5.4KS	5 in 1-Build in	3rd WiFi BG	BT 2.0
AOD150-1Br	NLED10.1WSV GAG	SO1GBI16	N160GB5.4KS	5 in 1-Build in	3rd WiFi BG	BT 2.0
AOD150-1Br	NLED10.1WSV GAG	SO1GBI16	N160GB5.4KS	5 in 1-Build in	3rd WiFi BG	BT 2.0
AOD150-1Br	NLED10.1WSV GAG	SO1GBI16	N160GB5.4KS	5 in 1-Build in	3rd WiFi BG	BT 2.0
AOD150-1Br	NLED10.1WSV GAG	SO1GBI16	N160GB5.4KS	5 in 1-Build in	3rd WiFi BG	BT 2.0
AOD150-1Br	NLED10.1WSV GAG	SO1GBI16	N160GB5.4KS	5 in 1-Build in	3rd WiFi BG	BT 2.0
AOD150-1Br	NLED10.1WSV GAG	SO1GBI16	N160GB5.4KS	5 in 1-Build in	3rd WiFi BG	BT 2.0
AOD150-1Br	NLED10.1WSV GAG	SO1GBI16	N160GB5.4KS	5 in 1-Build in	3rd WiFi BG	BT 2.0
AOD150-1Br	NLED10.1WSV GAG	SO1GBI16	N160GB5.4KS	5 in 1-Build in	3rd WiFi BG	BT 2.0
AOD150-1Br	NLED10.1WSV GAG	SO1GBI16	N160GB5.4KS	5 in 1-Build in	3rd WiFi BG	BT 2.0
AOD150-1Br	NLED10.1WSV GAG	SO1GBI16	N160GB5.4KS	5 in 1-Build in	3rd WiFi BG	BT 2.0
AOD150-1Br	NLED10.1WSV GAG	SO1GBI16	N160GB5.4KS	5 in 1-Build in	3rd WiFi BG	BT 2.0
AOD150-1Br	NLED10.1WSV GAG	SO1GBI16	N160GB5.4KS	5 in 1-Build in	3rd WiFi BG	BT 2.0
AOD150-1Br	NLED10.1WSV GAG	SO1GBI16	N160GB5.4KS	5 in 1-Build in	3rd WiFi BG	BT 2.0
AOD150-0Br	NLED10.1WSV GAG	SO1GBI16	N160GB5.4KS	5 in 1-Build in	3rd WiFi BG	N
AOD150-0Br	NLED10.1WSV GAG	SO1GBI16	N160GB5.4KS	5 in 1-Build in	3rd WiFi BG	BT 2.0
AOD150-0Br	NLED10.1WSV GAG	SO1GBI16	N160GB5.4KS	5 in 1-Build in	3rd WiFi BG	N
AOD150-1Bw	NLED10.1WSV GAG	SO1GBI16	N160GB5.4KS	5 in 1-Build in	3rd WiFi BG	BT 2.0
AOD150-0Bw	NLED10.1WSV GAG	SO1GBI16	N160GB5.4KS	5 in 1-Build in	3rd WiFi BG	BT 2.0
AOD150-1Bw	NLED10.1WSV GAG	SO1GBI16	N160GB5.4KS	5 in 1-Build in	3rd WiFi BG	BT 2.0

Model	LCD	Memory 1	HDD 1(GB)	Card Reader	Wireless LAN	BT
AOD150-1Bw	NLED10.1WSV GAG	SO1GBII6	N160GB5.4KS	5 in 1-Build in	3rd WiFi BG	N
AOD150-1Bw	NLED10.1WSV GAG	SO1GBII6	N160GB5.4KS	5 in 1-Build in	3rd WiFi BG	BT 2.0
AOD150-1Bw	NLED10.1WSV GAG	SO1GBII6	N160GB5.4KS	5 in 1-Build in	3rd WiFi BG	BT 2.0
AOD150-0Bw	NLED10.1WSV GAG	SO1GBII6	N160GB5.4KS	5 in 1-Build in	3rd WiFi BG	N
AOD150-0Bw	NLED10.1WSV GAG	SO1GBII6	N160GB5.4KS	5 in 1-Build in	3rd WiFi BG	BT 2.0
AOD150-0Bw	NLED10.1WSV GAG	SO1GBII6	N160GB5.4KS	5 in 1-Build in	3rd WiFi BG	N
AOD150-1Bw	NLED10.1WSV GAG	SO1GBII6	N160GB5.4KS	5 in 1-Build in	3rd WiFi BG	BT 2.0
AOD150-0Bw	NLED10.1WSV GAG	SO1GBII6	N160GB5.4KS	5 in 1-Build in	3rd WiFi BG	N
AOD150-1Bw	NLED10.1WSV GAG	SO1GBII6	N160GB5.4KS	5 in 1-Build in	3rd WiFi BG	BT 2.0
AOD150-0Bw	NLED10.1WSV GAG	SO1GBII6	N160GB5.4KS	5 in 1-Build in	3rd WiFi BG	BT 2.0
AOD150-1Bw	NLED10.1WSV GAG	SO1GBII6	N160GB5.4KS	5 in 1-Build in	3rd WiFi BG	BT 2.0
AOD150-1Bw	NLED10.1WSV GAG	SO1GBII6	N160GB5.4KS	5 in 1-Build in	3rd WiFi BG	BT 2.0
AOD150-1Bw	NLED10.1WSV GAG	SO1GBII6	N160GB5.4KS	5 in 1-Build in	3rd WiFi BG	N
AOD150-0Bw	NLED10.1WSV GAG	SO1GBII6	N160GB5.4KS	5 in 1-Build in	3rd WiFi BG	BT 2.0
AOD150-0Bw	NLED10.1WSV GAG	SO1GBII6	N160GB5.4KS	5 in 1-Build in	3rd WiFi BG	BT 2.0
AOD150-0Bw	NLED10.1WSV GAG	SO1GBII6	N160GB5.4KS	5 in 1-Build in	3rd WiFi BG	N
AOD150-1Bw	NLED10.1WSV GAG	SO1GBII6	N160GB5.4KS	5 in 1-Build in	3rd WiFi BG	BT 2.0
AOD150-1Bw	NLED10.1WSV GAG	SO1GBII6	N160GB5.4KS	5 in 1-Build in	3rd WiFi BG	N
AOD150-0Bw	NLED10.1WSV GAG	SO1GBII6	N160GB5.4KS	5 in 1-Build in	3rd WiFi BG	BT 2.0
AOD150-0Bw	NLED10.1WSV GAG	SO1GBII6	N160GB5.4KS	5 in 1-Build in	3rd WiFi BG	BT 2.0
AOD150-1Bw	NLED10.1WSV GAG	SO1GBII6	N160GB5.4KS	5 in 1-Build in	3rd WiFi BG	BT 2.0
AOD150-1Bw	NLED10.1WSV GAG	SO1GBII6	N160GB5.4KS	5 in 1-Build in	3rd WiFi BG	BT 2.0
AOD150-1Bw	NLED10.1WSV GAG	SO1GBII6	N160GB5.4KS	5 in 1-Build in	3rd WiFi BG	BT 2.0
AOD150-0Bw	NLED10.1WSV GAG	SO1GBII6	N160GB5.4KS	5 in 1-Build in	3rd WiFi BG	N
AOD150-0Bw	NLED10.1WSV GAG	SO1GBII6	N160GB5.4KS	5 in 1-Build in	3rd WiFi BG	N
AOD150-0Bw	NLED10.1WSV GAG	SO1GBII6	N160GB5.4KS	5 in 1-Build in	3rd WiFi BG	N
AOD150-0Bw	NLED10.1WSV GAG	SO1GBII6	N160GB5.4KS	5 in 1-Build in	3rd WiFi BG	N

Model	LCD	Memory 1	HDD 1(GB)	Card Reader	Wireless LAN	BT
AOD150-0Bw	NLED10.1WSV GAG	SO1GBII6	N160GB5.4KS	5 in 1-Build in	3rd WiFi BG	N
AOD150-0Bw	NLED10.1WSV GAG	SO1GBII6	N160GB5.4KS	5 in 1-Build in	3rd WiFi BG	BT 2.0
AOD150-1Bw	NLED10.1WSV GAG	SO1GBII6	N160GB5.4KS	5 in 1-Build in	3rd WiFi BG	BT 2.0
AOD150-0Bw	NLED10.1WSV GAG	SO1GBII6	N160GB5.4KS	5 in 1-Build in	3rd WiFi BG	BT 2.0
AOD150-1Bw	NLED10.1WSV GAG	SO1GBII6	N160GB5.4KS	5 in 1-Build in	3rd WiFi BG	BT 2.0
AOD150-0Bw	NLED10.1WSV GAG	SO1GBII6	N160GB5.4KS	5 in 1-Build in	3rd WiFi BG	BT 2.0
AOD150-0Bw	NLED10.1WSV GAG	SO1GBII6	N160GB5.4KS	5 in 1-Build in	3rd WiFi BG	BT 2.0
AOD150-1Bw	NLED10.1WSV GAG	SO1GBII6	N160GB5.4KS	5 in 1-Build in	3rd WiFi BG	BT 2.0
AOD150-0Bw	NLED10.1WSV GAG	SO1GBII6	N160GB5.4KS	5 in 1-Build in	3rd WiFi BG	BT 2.0
AOD150-0Bw	NLED10.1WSV GAG	SO1GBII6	N160GB5.4KS	5 in 1-Build in	3rd WiFi BG	BT 2.0
AOD150-0Bw	NLED10.1WSV GAG	SO1GBII6	N160GB5.4KS	5 in 1-Build in	3rd WiFi BG	N
AOD150-1Bw	NLED10.1WSV GAG	SO1GBII6	N160GB5.4KS	5 in 1-Build in	3rd WiFi BG	N
AOD150-1Bw	NLED10.1WSV GAG	SO1GBII6	N160GB5.4KS	5 in 1-Build in	3rd WiFi BG	BT 2.0
AOD150-0Bw	NLED10.1WSV GAG	SO1GBII6	N160GB5.4KS	5 in 1-Build in	3rd WiFi BG	BT 2.0
AOD150-0Bw	NLED10.1WSV GAG	SO1GBII6	N160GB5.4KS	5 in 1-Build in	3rd WiFi BG	BT 2.0
AOD150-1Bw	NLED10.1WSV GAG	SO1GBII6	N160GB5.4KS	5 in 1-Build in	3rd WiFi BG	BT 2.0
AOD150-1Bw	NLED10.1WSV GAG	SO1GBII6	N160GB5.4KS	5 in 1-Build in	3rd WiFi BG	BT 2.0
AOD150-0Bw	NLED10.1WSV GAG	SO1GBII6	N160GB5.4KS	5 in 1-Build in	3rd WiFi BG	BT 2.0
AOD150-0Bw	NLED10.1WSV GAG	SO1GBII6	N160GB5.4KS	5 in 1-Build in	3rd WiFi BG	BT 2.0
AOD150-0Bw	NLED10.1WSV GAG	SO1GBII6	N160GB5.4KS	5 in 1-Build in	3rd WiFi BG	N
AOD150-0Bw	NLED10.1WSV GAG	SO1GBII6	N160GB5.4KS	5 in 1-Build in	3rd WiFi BG	N
AOD150-0Bw	NLED10.1WSV GAG	SO1GBII6	N160GB5.4KS	5 in 1-Build in	3rd WiFi BG	N
AOD150-0Bw	NLED10.1WSV GAG	SO1GBII6	N160GB5.4KS	5 in 1-Build in	3rd WiFi BG	N
AOD150-1Bw	NLED10.1WSV GAG	SO1GBII6	N160GB5.4KS	5 in 1-Build in	3rd WiFi BG	BT 2.0
AOD150-1Bw	NLED10.1WSV GAG	SO1GBII6	N160GB5.4KS	5 in 1-Build in	3rd WiFi BG	BT 2.0
AOD150-1Bw	NLED10.1WSV GAG	SO1GBII6	N160GB5.4KS	5 in 1-Build in	3rd WiFi BG	N

Model	LCD	Memory 1	HDD 1(GB)	Card Reader	Wireless LAN	BT
AOD150-1BGw	NLED10.1WSV GAG	SO1GBI16	N160GB5.4KS	5 in 1-Build in	3rd WiFi BG	BT 2.0
AOD150-0BGw	NLED10.1WSV GAG	SO1GBI16	N160GB5.4KS	5 in 1-Build in	3rd WiFi BG	BT 2.0
AOD150-0BGw	NLED10.1WSV GAG	SO1GBI16	N160GB5.4KS	5 in 1-Build in	3rd WiFi BG	BT 2.0
AOD150-1BGw	NLED10.1WSV GAG	SO1GBI16	N160GB5.4KS	5 in 1-Build in	3rd WiFi BG	BT 2.0
AOD150-0BGw	NLED10.1WSV GAG	SO1GBI16	N160GB5.4KS	5 in 1-Build in	3rd WiFi BG	BT 2.0
AOD150-0BGw	NLED10.1WSV GAG	SO1GBI16	N160GB5.4KS	5 in 1-Build in	3rd WiFi BG	N

Test Compatible Components

This computer's compatibility is tested and verified by Acer's internal testing department. All of its system functions are tested under Windows® XP Home, Windows® XP Pro environment.

Refer to the following lists for components, adapter cards, and peripherals which have passed these tests. Regarding configuration, combination and test procedures, please refer to the Aspire one series Compatibility Test Report released by the Acer Mobile System Testing Department.

Windows XP Environment Test

Vendor	Type	Description
3G Card		
9999995 ONE TIME VENDER	GTM380E	3G GTM380E
9999995 ONE TIME VENDER	UNDP-1	3G UNDP-1
9999995 ONE TIME VENDER	GTM380E	3G GTM380E
10000981 MISC	GTM382E	Option 3G GTM382EL
9999995 ONE TIME VENDER	GTM380E	3G GTM380E
9999995 ONE TIME VENDER	GTM380E	3G GTM380E
10000981 MISC	GTM382E	Option 3G GTM382EL
10000981 MISC	GTM382E	Option 3G GTM382EL
Adapter		
10001081 DELTA	30W	Adapter DELTA 30W 19V 1.7x5.5x11 Black ADP-30JH BA LF
60003544 LITE-ON OPT	30W	Adapter LITE-ON 30W 19V 1.7x5.5x11 Black PA-1300-04AC LF
60002015 HIPRO	30W	Adapter HIPRO 30W 19V 1.7x5.5x11 Black HP-A0301R3 B1LF LF
Audio Codec		
9999995 ONE TIME VENDER	ALC268	ALC268
9999995 ONE TIME VENDER	ALC268	ALC268
10001028 QUANTA	ALC272X	Realtek Audio Codec ALC272X
9999995 ONE TIME VENDER	ALC268	ALC268
Battery		
60001921 SANYO	3CELL2.2	Battery SANYO UM-2008A Li-Ion 3S1P SANYO 3 cell 2200mAh Main COMMON Macles
60001921 SANYO	3CELL2.2	Battery SANYO UM-2008AW Li-Ion 3S1P SANYO 3 cell 2200mAh Main COMMON Macles / White
60001535 PANASONIC	3CELL2.2	Battery PANASONIC UM-2008A Li-Ion 3S1P PANASONIC 3 cell 2200mAh Main COMMON Macles

Vendor	Type	Description
60001535 PANASONIC	3CELL2.2	Battery PANASONIC UM-2008AW Li-Ion 3S1P PANASONIC 3 cell 2200mAh Main COMMON Macles / White
60001535 PANASONIC	3CELL2.9	Battery PANASONIC UM-2008A Li-Ion 3S1P PANASONIC 3 cell 2900mAh Main COMMON
60001535 PANASONIC	3CELL2.9	Battery PANASONIC UM-2008AW Li-Ion 3S1P PANASONIC 3 cell 2900mAh Main COMMON white color
60002162 SIMPLO	3CELL2.2	Battery SIMPLO UM-2008A Li-Ion 3S1P PANASONIC 3 cell 2200mAh Main COMMON Macles
60002162 SIMPLO	3CELL2.2	Battery SIMPLO UM-2008A Li-Ion 3S1P SAMSUNG 3 cell 2200mAh Main COMMON Macles
60001535 PANASONIC	6CELL2.9	Battery PANASONIC UM-2008B Li-Ion 3S2P PANASONIC 6 cell 5800mAh Main COMMON Black, Macles
60001535 PANASONIC	6CELL2.9	Battery PANASONIC UM-2008BW Li-Ion 3S2P PANASONIC 6 cell 5800mAh Main COMMON white, Macles
60002162 SIMPLO	6CELL2.2	Battery SIMPLO UM-2008A Li-Ion 3S2P PANASONIC 6 cell 4400mAh Main COMMON Macles
60002162 SIMPLO	6CELL2.2	Battery SIMPLO UM-2008A Li-Ion 3S2P SAMSUNG 6 cell 4400mAh Main COMMON Macles
60002162 SIMPLO	6CELL2.2	Battery SIMPLO UM-2008BW Li-Ion 3S2P SAMSUNG 6 cell 4400mAh Main COMMON white color, F type
60002162 SIMPLO	6CELL2.6	Battery SIMPLO UM-2008B Li-Ion 3S2P PANASONIC 6 cell 5200mAh Main COMMON Macles Black
60002162 SIMPLO	6CELL2.2	Battery SIMPLO UM-2008BW Li-Ion 3S2P PANASONIC 6 cell 4400mAh Main COMMON White color, PSS CG type
60002162 SIMPLO	6CELL2.6	Battery SIMPLO UM-2008B Li-Ion 3S2P SAMSUNG 6 cell 5200mAh Main COMMON Macles Black
60002162 SIMPLO	6CELL2.6	Battery SIMPLO UM-2008BW Li-Ion 3S2P PANASONIC 6 cell 5200mAh Main COMMON Macles White
60002162 SIMPLO	6CELL2.6	Battery SIMPLO UM-2008BW Li-Ion 3S2P SAMSUNG 6 cell 5200mAh Main COMMON Macles White
60002162 SIMPLO	6CELL2.6	Battery SIMPLO UM-2008B Li-Ion 3S2P LGC 6 cell 5200mAh Main COMMON Black, LGC 2.6 (B3)
60002162 SIMPLO	6CELL2.6	Battery SIMPLO UM-2008BW Li-Ion 3S2P LGC 6 cell 5200mAh Main COMMON White, LGC 2.6 (B3)
60002162 SIMPLO	6CELL2.6	Battery SIMPLO UM-2008B Li-Ion 3S2P SAMSUNG 6 cell 5200mAh Main COMMON 2.6(C), black, new fuse (NEC)
60002162 SIMPLO	6CELL2.6	Battery SIMPLO UM-2008BW Li-Ion 3S2P SAMSUNG 6 cell 5200mAh Main COMMON 2.6(C), white, new fuse (NEC)
60002162 SIMPLO	3CELL2.2	Battery SIMPLO UM-2008AW Li-Ion 3S1P PANASONIC 3 cell 2200mAh Main COMMON Macles / White
60002162 SIMPLO	3CELL2.2	Battery SIMPLO UM-2008AW Li-Ion 3S1P SAMSUNG 3 cell 2200mAh Main COMMON Macles / White
60002162 SIMPLO	3CELL2.2	Battery SIMPLO UM-2008A Li-Ion 3S1P SAMSUNG 3 cell 2200mAh Main COMMON 2.2(F), black, new fuse
60002162 SIMPLO	3CELL2.2	Battery SIMPLO UM-2008AW Li-Ion 3S1P SAMSUNG 3 cell 2200mAh Main COMMON 2.2 (F), white, new fuse (NEC)
60001921 SANYO	6CELL2.6	Battery SANYO UM-2008BW Li-Ion 3S2P SANYO 6 cell 5200mAh Main COMMON white
60001921 SANYO	6CELL2.2	Battery SANYO UM-2008B Li-Ion 3S2P SANYO 6 cell 4400mAh Main COMMON Black, 2.2Ah (A)

Vendor	Type	Description
60001921 SANYO	6CELL2.6	Battery SANYO UM-2008B Li-Ion 3S2P SANYO 6 cell 5200mAh Main COMMON Black
60001921 SANYO	6CELL2.2	Battery SANYO UM-2008BW Li-Ion 3S2P SANYO 6 cell 4400mAh Main COMMON White, 2.2 Ah (A)
Bluetooth		
9999995 ONE TIME VENDER	BT 2.0	Foxconn Bluetooth FOX_BRM_2.0 F/W 300
Camera		
9999995 ONE TIME VENDER	0.3M LDV	Suyin Camera Rosa
9999995 ONE TIME VENDER	0.3M LDV	Liteon Camera Lily
Card Reader		
9999995 ONE TIME VENDER	5 in 1-Build in	5 in 1-Build in MS, MS Pro, SD, SC, XD
CPU/Processor		
10001067 INTEL	ATMN270B	CPU Intel Atom N270 1.6G 512K 533 2.5W
10001067 INTEL	ATMN280B	CPU Intel Atom N280 BGA 1.66G 512K 667 2.5W C-0
HDD		
60002036 SEAGATE	N160GB5.4KS	HDD SEAGATE 2.5" 5400rpm 160GB ST9160310AS Crockett SATA LF F/W:0303
60002036 SEAGATE	N250GB5.4KS	HDD SEAGATE 2.5" 5400rpm 250GB ST9250315AS Wyatt SATA LF F/W:0001SDM1
60002005 HGST SG	N250GB5.4KS	HDD HGST 2.5" 5400rpm 250GB HTS543225L9A300 Falcon-B SATA LF F/W:C40C
60001994 WD	N250GB5.4KS	HDD WD 2.5" 5400rpm 250GB WD2500BEVT-22ZCT0 ML160 SATA LF F/W:11.01A11
60001922 TOSHIBA DIGI	N160GB5.4KS	HDD TOSHIBA 2.5" 5400rpm 160GB MK1652GSX Virgo - BS SATA LF F/W:LV010J
60002005 HGST SG	N160GB5.4KS	HDD HGST 2.5" 5400rpm 160GB HTS543216L9A300 Falcon-B SATA LF F/W:C40C
60001994 WD	N160GB5.4KS	HDD WD 2.5" 5400rpm 160GB WD1600BEVT-22ZCTO ML160 SATA LF F/W:11.01A11
60002036 SEAGATE	N250GB5.4KS	HDD SEAGATE 2.5" 5400rpm 250GB ST9250827AS Corsair SATA LF F/W:3.AAA
60002215 SAMSUNG	F160GB	Flash Disk SAMSUNG Flash Module NAND 16GB MMBRE16GSMPP-MVA LF
60001922 TOSHIBA DIGI	N160GB5.4KS	HDD TOSHIBA 2.5" 5400rpm 160GB MK1655GSX Libra SATA LF F/W: FG011J
Keyboard		
820123 DARFON	8KB-FV1 Black	Keyboard 8KB-FV1 Black Macles Standard

Vendor	Type	Description
820123 DARFON	L8KB-FV1 Black	Keyboard 8KB-FV1L Black Macles Standard Linux
820123 DARFON	8KB-FV2 White	Keyboard 8KB-FV2 White Macles Internal Standard White
820123 DARFON	L8KB-FV2 White	Keyboard 8KB-FV2L White Macles Internal Standard White Linux
LAN		
60003333 ZERO ONE	AR8114	Atheros AR8114 AR8114
LCD		
10001038 CMO	NLED10.1WS VGAG	LED LCD CMO 10.1" WSVGA Glare N101L6-L02 LF 200nit 8ms 400:1
60003316 AUO	NLED10.1WS VGAG	LED LCD AUO 10.1" WSVGA Glare B101AW03 V0 LF 200nit 8ms 500:1
60003089 LG	NLED10.1WS VGAG	LED LCD LPL 10.1" WSVGA Glare LP101WSA-TLA1 LF 200nit 16ms 400:1
60002215 SAMSUNG	NLED10.1WS VGAG	LED LCD SAMSUNG 10.1" WSVGA Glare LTN101NT02-A01 LF 200nit 16ms 400:1
Memory		
60002215 SAMSUNG	SO1GBII6	Memory SAMSUNG SO-DIMM DDRII 667 1GB M470T2864EH3-CE6 LF 64*16 0.055um
60002045 HYNIX	SO1GBII6	Memory HYNIX SO-DIMM DDRII 667 1GB HMP112S6EFR6C-Y5 LF 64*16 0.055um
60001993 NANYA	SO1GBII6	Memory NANYA SO-DIMM DDRII 667 1GB NT1GT64UH8D0FN-3C LF 64*16 0.07um
60001993 NANYA	SO2GBII6	Memory NANYA SO-DIMM DDRII 667 2GB NT2GT64U8HD0BN-3C LF 128*8 0.07um
60002215 SAMSUNG	SO2GBII6	Memory SAMSUNG SO-DIMM DDRII 667 2GB M470T5663EH3-CE6 LF 128*8 0.055um
60002045 HYNIX	SO2GBII6	Memory HYNIX SO-DIMM DDRII 667 2GB HMP125S6EFR8C-Y5 LF 128*8 0.055um
60002215 SAMSUNG	SO512MBII6	Memory SAMSUNG SO-DIMM DDRII 667 512MB M470T6464QZ3-CE6 LF
60002045 HYNIX	SO512MBII6	Memory HYNIX SO-DIMM DDRII 667 512MB HYMP164S64CP6-Y5 LF 64*16 0.065um
60002215 SAMSUNG	SO1GBII6	Memory SAMSUNG SO-DIMM DDRII 667 1GB M470T2864QZ3-CE6 LF
60002045 HYNIX	SO1GBII6	Memory HYNIX SO-DIMM DDRII 667 1GB HYMP112S64CP6-Y5 LF
16081942 MICRON	SO1GBII6	Memory MICRON SO-DIMM DDRII 667 1GB MT8HTF12864HDY-667G1 LF 64*16 0.065um
Norhtbridge Chipset		
10001067 INTEL	945GSE	NB Chipset Intel CS QG82945GSE MM#897840
ODD		
60001535 PANASONIC	NVMROM2X	ODD PANASONIC VMedia ROM 13mm Cartridge 2X UJ610 LF W/ O bezel PATA For Jasper
60001535 PANASONIC	NVMROM2X	ODD PANASONIC VMedia ROM 13mm Cartridge 2X UJ610 LF W/ O bezel PATA For Jasper

Vendor	Type	Description
60001535 PANASONIC	NVMROM2X	ODD PANASONIC VMedia ROM 13mm Cartridge 2X UJ610 LF W/ O bezel PATA For Jasper
Southbridge		
10001067 INTEL	ICH7M	ICH7M
Software		
10000981 MISC	McAfee	Antivirus application McAfee
WiFi Antenna		
9999995 ONE TIME VENDER	PIFA	PIFA
WLAN		
10001067 INTEL	EP1x2MMW	WiMax Intel WLAN 512ANXMMWG Echo Peak 5150 MM#895364
23707801 FOXCONN TW	3rd WiFi BG	Foxconn FOX_ATH_XB63 Foxconn Atheros XB63 minicard b/g
9999995 ONE TIME VENDER	3rd WiFi BG	Foxconn Wireless LAN Broadcom 4312 minicard b/g

Online Support Information

This section describes online technical support services available to help you repair your Acer Systems.

If you are a distributor, dealer, ASP or TPM, please refer your technical queries to your local Acer branch office. Acer Branch Offices and Regional Business Units may access our website. However some information sources will require a user i.d. and password. These can be obtained directly from Acer CSD Taiwan.

Acer's Website offers you convenient and valuable support resources whenever you need them.

In the Technical Information section you can download information on all of Acer's Notebook, Desktop and Server models including:

- Service guides for all models
- User's manuals
- Training materials
- Bios updates
- Software utilities
- Spare parts lists
- TABs (Technical Announcement Bulletin)

For these purposes, we have included an Acrobat File to facilitate the problem-free downloading of our technical material.

Also contained on this website are:

- Detailed information on Acer's International Traveler's Warranty (ITW)
- Returned material authorization procedures
- An overview of all the support services we offer, accompanied by a list of telephone, fax and email contacts for all your technical queries.

We are always looking for ways to optimize and improve our services, so if you have any suggestions or comments, please do not hesitate to communicate these to us.

A

Antennas 88

B

Battery Pack 42

BIOS

ROM size 15

ROM type 15

vendor 15

Version 15

BIOS Utility 19–30

Advanced 23

Boot 28

Exit 29

Navigating 19

Power 26

Save and Exit 29

Security 23

System Security 29

Bluetooth Module 69

Board Layout

Top View 135

brightness

hotkeys 11

C

Camera Board 82

Camera Cable 87

caps lock

on indicator 7

Common Problems 118

D

DIMM Module 48

Display 3

display

hotkeys 11

E

Euro 12

External Module Disassembly

Flowchart 41

F

Features 1

FLASH Utility 30

Flash Utility 30

FPC Cable 84

FRU (Field Replaceable Unit) List 139

H

Hard Disk Drive Module 46

Hibernation mode

hotkey 11

Hot Keys 9

I

Indicators 7

Intermittent Problems 128

Internal Microphone Failure 124

Internal Power Cable 71

Internal Speaker Failure 122

J

Jumper and Connector Locations 135

Top View 135

K

Keyboard 52

Keyboard Failure 121

L

LCD Bezel 80

LCD Bracket Extensions 79

LCD Brackets 84

LCD Failure 121

LCD Module Disassembly

Flowchart 78

LCD Panel 83

Lower Covers 44

M

Main Unit Disassembly
 Flowchart 51
Mainboard 71
media access
 on indicator 7
Memory Check 118
MIC Board 86
Model Definition 158

N

No Display Issue 119
Notebook Manager
 hotkey 11
num lock
 on indicator 7

O

ODD Failure 126
Online Support Information 217

P

Panel 4
 Bottom 6
 left 4
PC Card 7
POST Codes
 Reference Tables 129
Power Button Failure 126
Power On Failure 118

R

RTC Battery 66

S

SD Dummy Card 43
Speaker Module 74
speakers
 hotkey 11
System
 Block Diagram 3

T

Test Compatible Components 211

Thermal Module 76
Top 135
Touch Pad
 hotkey 11
Touch Pad Failure 122
Troubleshooting
 Built-in KB Failure 121
 Internal Microphone 124
 Internal Speakers 122
 LCD Failure 121
 No Display 119
 ODD 126
 Other Failures 127
 Power Button 126
 Power On 118
 Touch Pad 122
 USB 126
 WLAN 127

U

Undetermined Problems 128
Upper Cover 54
USB Board 67
USB Cable 67
USB Failure (Rightside) 126
utility
 BIOS 19–30

V

volume
 hotkeys 11

W

Windows 2000 Environment Test 212
Wireless Function Failure 127
WLAN Board 49, 51
WLAN Module 49