

# SENCOR®

## SMC 603

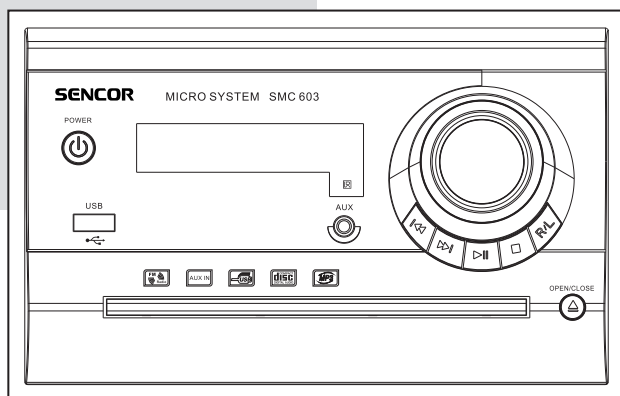

**USER MANUAL**

**UŽIVATELSKÁ PŘÍRUČKA**

**NÁVOD NA OBSLUHU**

**FELHASZNÁLÓI KÉZIKÖNYV**

**INSTRUKCJA OBSŁUGI**

**MICRO HI-FI SYSTEM**

**MIKROSYSTÉM**

**MIKROSYSTÉM**

**MIKRORENDSZER**

**MIKROSYSTEM**

**EN CZ SK HU PL**

# Catalogue

SAFETY INSTRUCTIONS.....	3
PRECAUTIONS.....	4
SYSTEM CONNECTION.....	6
PANEL INSTRUCTION.....	7
REMOTE CONTROL.....	7
BASIC OPERATION.....	9-10
USB COPY.....	11
RADIO/AUDIO INPUT OPERATION.....	12-13
TROUBLESHOOTING GUIDE.....	14
SPECIFICATION.....	15

# Safety Instructions

When designing this product, designers take full consideration of safety and other problems. However, it will cause electric shock or fire if operating inappropriately. Therefore, users should operate this machine according to the following instructions.

This CD Player adopts semiconductor unit, not including spare parts for users to replace. Don't take apart the machine by yourself to avoid electric shock. If the machine is damaged, please ask the qualified maintenance worker to repair.

## **Power**

Power of this player should be used corresponding to the information on the rating label.

## **Ventilation**

The function of air vent on the main case is to keep CD Player from overheating. Don't block or cover the air vent and put the player on the bed or sofa.

## **Heat Source**

The machine should be kept away from heat source, such as stoves and direct sunlight.

## **Water and Moisture**

Don't use this machine in the humid environment, such as bathroom, kitchen, humid basement and so on.

## **Cleaning**

Before cleaning, please put the power off first. Don't use liquid cleaners or corrosive fluid to clean the machine, just clean it by a soft cloth.

## **Disc Tray Door**

While closing the disc tray door, keep fingers away from it to avoid being damaged.

## **Loading Weight**

Don't put any heavy objects on the machine in order to keep the machine from being damaged.

## **Connecting Other Equipments**

Before connecting other equipments with the CD Player, make sure to put off the power. Otherwise, it will make equipments or users damaged.

## **Radium Laser**

While the case is open and the CD Player is working, don't look at the laser directly with naked eyes, otherwise, it will have a bad influence on the eyesight.

## **Disc**

Avoid using the disc which is cracking, deformed or repaired, otherwise, the machine will appear malfunction or shorten usage life.

## **Malfunction Requirng Maintenance**

If the following problems appear, please put off the power, and contact the qualified maintenance worker.

- A. The power cord or plug is damaged.
- B. Liquid or other foreign matters in the unit.
- C. The machine is caught in the rain or watered.
- D. While the machine can't work even according to the manual operation, don't press other button which aren't mentioned on the manual. Otherwise, it will cause the machine damaged and take the mainantence worker more time to fix.

- E. The machine drops from high place.
- F. The inner part gives out a burnt smell.

### **Maintenance**

If you aren't familiar with the maintenance technical skill of the machine, don't try to fix it by yourself. If you open the main case, you might get electric shock. If needed, contact the qualified maintenance worker.

### **Spare Parts Replacement**

While needing spare parts replacement, ask maintenance worker to replace the same model spare parts. If replacing different model parts, it may cause more serious malfunction, electric shock or shorten usage life.

### **Safety Inspection**

After maintenance, request maintenance worker to implement site safety inspection to make sure the machine works safely.

*Note: Please read the manual carefully before using the machine, and keep it well for using in the future.*

## **Precautions**

1. When carrying the CD Player, use the original shipping carton and packing materials. It's the best way to protect the player with the factory package.
2. Don't place the CD Player nearby volatile liquid, and don't let the rubber or plastics product to connect with the player for a long time, which will leave traces on the machine cover.
3. After working for a long time, the upper cover or rear panel will give out heat, which belongs to normal phenomenon not malfunction.
4. While not using the CD Player, please take disc out and close the disc chamber, then turn off the power.
5. While not using the CD Player for a long time, some functional button may not work. In order to avoid appearing that phenomenon, advise to use it for a while or pay attention to moistureproof.

### **Location Precautions**

While placing the CD Player at the side of TV, Radio or Video Recorder, it may appear phenomenon like the sound loses true. Therefore, keep the CD Player away from that kind of equipment.

### **Cleaning Precautions**

1. Cleaning by a soft cloth
2. Using a cloth with a little bit diluted detergent to wash the stain. Please remind that don't use any dissolvent such as thinner, gasoline solvents and volatile liquid, for which will damage the player cover.
3. Using chemical soaked cloth to clean the CD Player, Please wash the player according to the usage instruction.

*Note: Cleaning and adjusting interior parts have to be operated by qualified maintenance worker, otherwise damage the player or shorten usage life.*

## Disc Usage Precautions

1. How to get a disc: don't touch the side of playing



2. Cleaning Disc: clean the disc from the center to outside by a soft cloth. If the picture and sound quality was influenced because of fingerprints or dust on the disc, wiping the disc by a wet cloth and then wiping by a dry cloth. Don't use Dissolved in toluene, detergent or Anti static spray to wash the disc, or damage it.



3. Storing the disc: placing the disc to the disc box instead of humid or dusty place and direct sunshine place.



## Battery Precautions

If using batteries incorrectly, the battery fluid would leak or the battery will be corroded. Therefore, please operate correctly as the following instruction.

1. While putting batteries into remote control, don't take anti to the positive and negative polarity of the battery.
2. Don't charge the battery (not rechargeable batteries), disassemble and decompose the battery or put it into fire.
3. Don't use different models batteries together or new batteries with old ones.
4. Don't leave damaged or dead battery into the remote control.
5. If not using the remote control for a long time, put batteries out to protect it from being damaged for battery fluid leaking.
6. If the remote control work abnormally or effective picture narrows, replace new batteries.
7. If battery fluid leaks, clean the battery case first and then replace new battery.

## Remote Control Precautions

If using the remote control incorrectly, it would appear that the CD Player reception is not good enough or there is no reception. Therefore, please use it correctly as following instructions.

1. Keeping remote control launch head from being illuminated directly by intensive light source like sunlight, which leads to no reception or bad reception.
2. Put the remote control aim at the receiving window on the CD Player.
3. Don't drop the remote control or shock intensively.
4. Don't put water or other liquids into the remote control.
5. Don't take apart the remote control.

### Note:

1. Keep the distance within about 7 meters between the remote control and the CD Player.
2. Keep omnibearing 30 degrees from the remote to receiving window.
3. Put the batteries into battery case of remote control, and then operate it.

# System Connection

## Audio Input Instruction

Audio Input

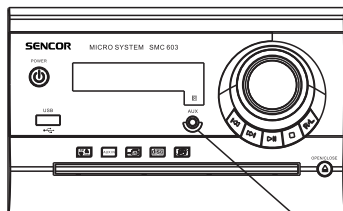

The left and right channel audio conjunction line



Connect DVD, MP3 and other audio-visual products to the audio input jack according to left/ right sound track.

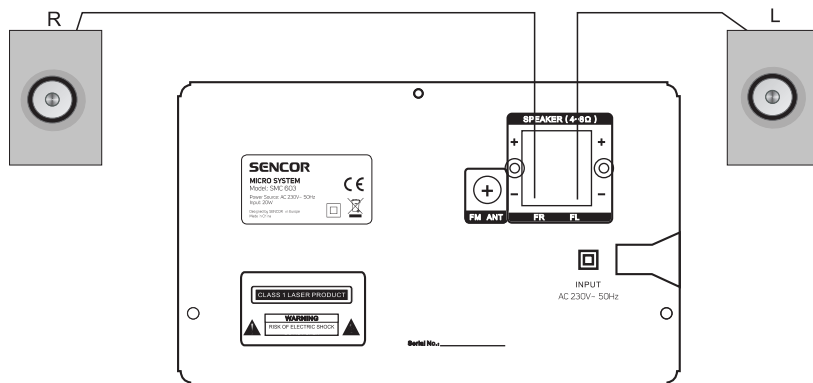

**Note:**

While connecting the speakers, don't make a short circuit of anode and cathode or short circuit of shell, which will cause the system damaged.

While connecting the CD Player with other audio-visual products, please make sure to turn off the power and pull out the plug.

# Panel Instruction

## Front Panel Function

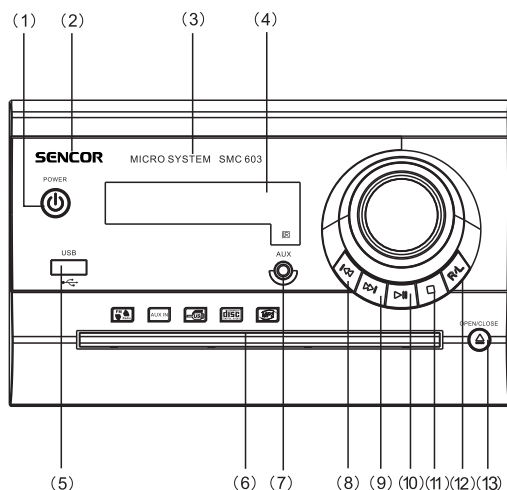

1. Power switch function key
2. Logo function key
3. Product model function key
4. Display function key
5. Usb function key
6. CD door
7. AUX Input Jack
8. Previous function key
9. Next function key
10. Play/pause function key
11. Stop function key
12. R/L sound track
13. Open/close function key

## Rear Panel Function

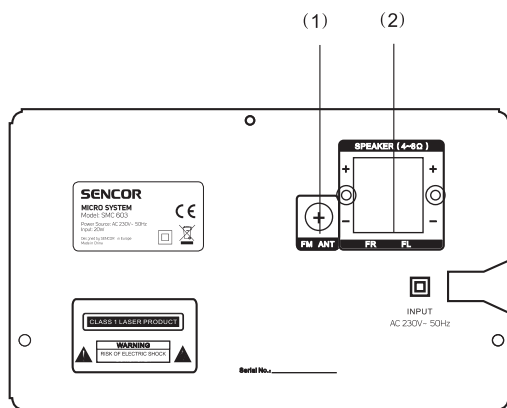

1. FM Radio Antenna Jack
2. Wire Clamp for Speakers

# Remote Control

## Remote Control Instruction

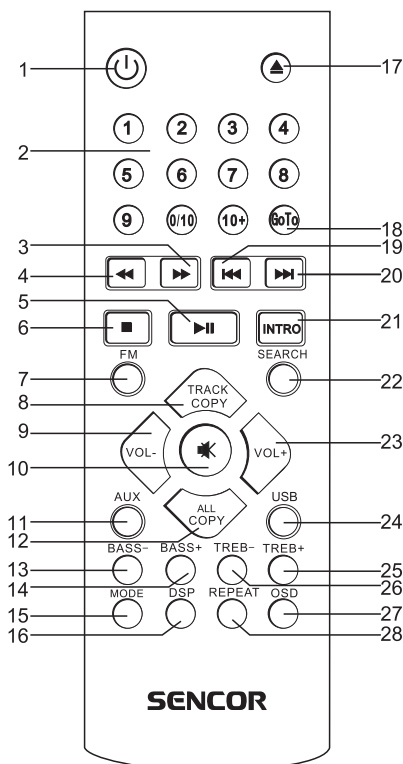

1. Standby Function key
2. Number Function key
3. Forward Function key
4. Reverse Function key
5. Play/Pause Function key
6. Stop Function key
7. FM Radio Function key
8. Single Copy Function key
9. Volume - Function key
10. Mute Function key
11. AUX Input Function key
12. All Copy Function key
13. Bass - Function key
14. Bass + Function key
15. Audio Mode Function key
16. Display Function key
17. Disc Chamber Function key
18. FM frequency selection Function key
19. Previous Function key
20. Next Function key
21. Audition Function key
22. Radio Search Function key
23. Volume + Function key
24. USB Function key
25. Treble + Function key
26. Treble - Function key
27. On-Screen Display Function key
28. Repeat Function key

### Note:

key 1 : press for standby, on, off mode sequentially when powered on.

key 12 : press for whole disc copy to USB.

key 15 : DISC mode: press for sequential option of Steres, MONO L, and then MONO R; FM mode: press for option of Mono or Stereo.

key 18 : for FM frequency selection.

eg : for 90 MHZ , press „Go To“, then press number 09000; for 100.3 MHZ, Press „Go To“, then press number 10030.

key 21 : press for sequential audition from track one to end, each 10 seconds.

key 27 : press for displaying minutes track remained, total minutes from track one to track played, minutes whole disc remained.

key 28 : disc mode :press sequentially for rep 1, rep all and rep off; USB mode: press sequentially for rep 1, rep dlr, rep all and rep off.



# Basic Operation

## 1. Power Switch

After connecting the CD player lines, press POWER button on the front panel, and the screen is bright, then insert CD Disk or USB to play.

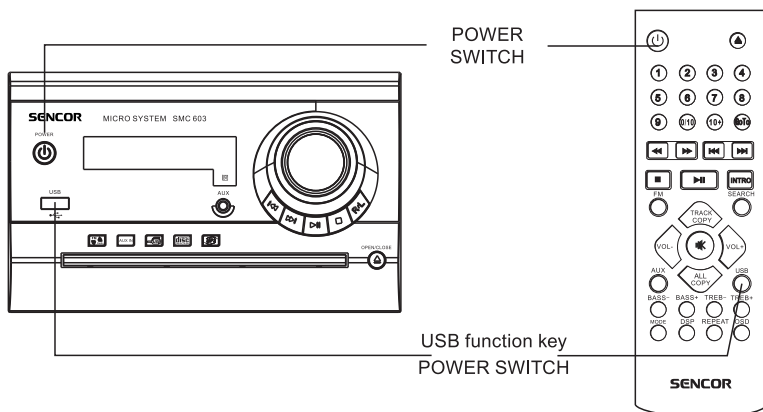

## 2. Volume Adjustment

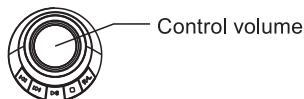

## 3. Tone Setup

1. Bass Setup: Press BASS-/BASS+ on the remote control to turn down or up Bass (between -14 and +14)

BA 14 ~ BA -14

2. Treble Setup: Press TREBLE-/TREBLE+ on the remote control to turn down or up Treble (between -14 and +14).

TR 14 ~ TR -14

3. Dual Mono: Press MODE on the remote control, there are three kinds of sound output to be selected: MONO L, MONO R and STEREO.

STEREO MONO L MONO R

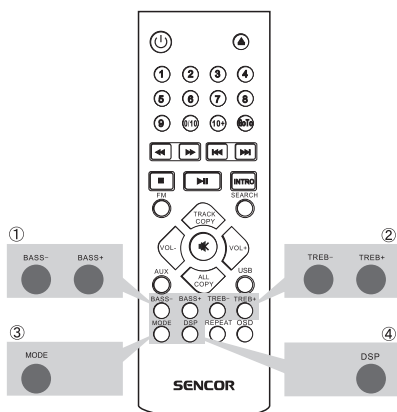

4. Display Setup: Press DSP on the remote control, then the sound five kinds of different sound field to be chosen.

DSP 00  
 }  
 DSP 04



# Basic Operation

## 4. CD Player

Stiskněte tlačítko POWER na předním panelu pro zapnutí a pak stiskněte tlačítko  na předním panelu nebo tlačítko  na dálkovém ovladači pro otevření diskové mechaniky. Pak vložte správným způsobem disk a znovu stiskněte tlačítko  - po několika sekundách se automaticky spustí přehrávání disku.

## 5. Play Pause Stop

While playing, press  on the front panel or  on the remote control to stop for a while, then the Disc will be paused to play. Press  once more, the Disc resumes to play.

While playing, press  on the front panel or  on the remote control to stop for a while, then the Disc will be stopped to play. Press , the Disc replays.

## 6. Previous Next

While playing, press  on the front panel or  on the remote control to the previous chapter played.

While playing, press  on the front panel or  on the remote control to the next chapter.

### Note:

Change to disc mode (from either USB, FM, AUX), press key 5 „play“.

When playing a CD with MP3 files, the number of tracks is shown on the screen. The individual folders are not shown.

## USB Usage

1. When no disc is in the CD PLAYER, inserting USB to the USB jack and playing the chapters on the USB automatically after several minutes.



2. When disc and USB are in the CD PLAYER, the disc will be played first. If swifiting to USB, press USB button on the remote control, then the disc will be stopped playing, and chapters on the USB will be played.

### Note:

1. When playing the chapters on the USB, other operations are the same as the Disc's.

2. Supportive USB files: MP3, WMA.

When playing a USB device, the number of tracks is shown on the screen. The individual folders are not shown.

The USB memory device should not contain any files with the .exe extension. This could damage the micro hi-fi system.

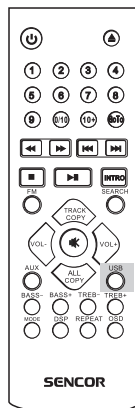

USB

# USB Copy

## USB Record

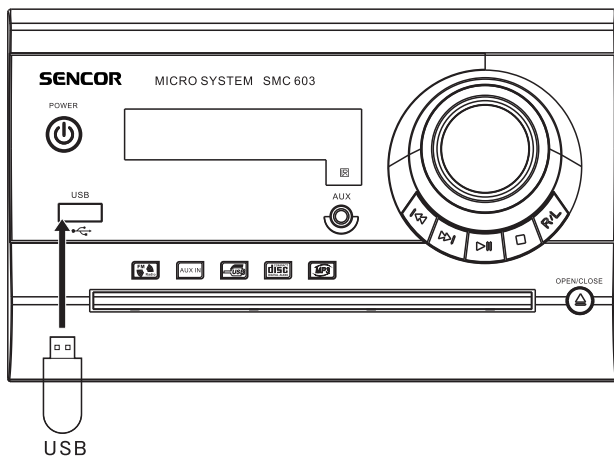

## USB Copy

1. While the CD Player is playing CD disc, you can insert USB to USB jack, and press TRACK COPY on the remote control or ALL COPY to record.
2. While the CD Player is playing MP3 disc, you can insert USB to USB jack, and press TRACK COPY to record.

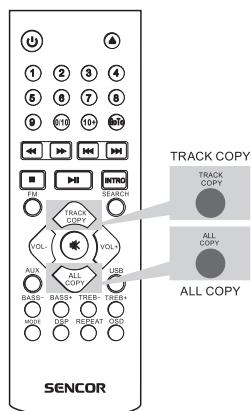



# Radio / Audio Input Operation

## Setup

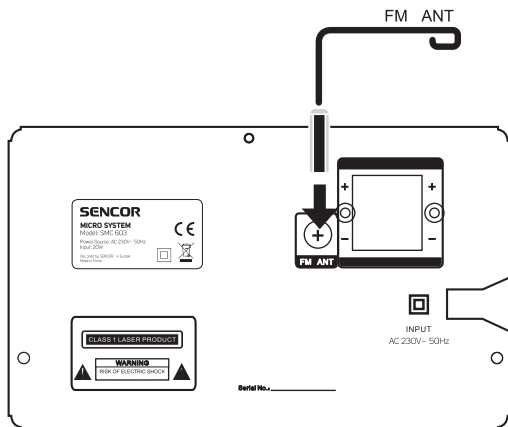
When you want to listen to radio program, put the radio antenna into the antenna jack on the rear panel, and put FM button on the remote control. The CD Player is on the situation of radio, and press SEARCH button to search radio channel automatically between 87.5 MHz and 108 MHz. The micro hi-fi system automatically remembers the radio stations after scanning them.



## Basic Operation

1. When you are listening to radio program, press MODE button on the remote control, then you can swift the sound track between stereo and mono lang.
2. When you are listening to radio program, press  on the remote control to the next channel; press  won the remote control to the previous channel.
3. When you are listening to radio program, press  on the remote control to search channels up and down.

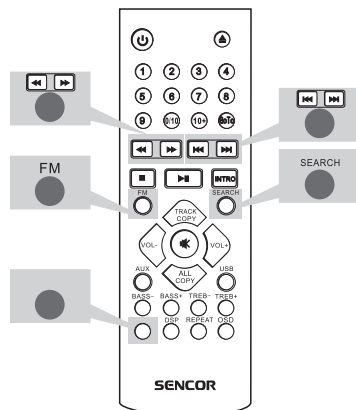

# Radio/Audio Input Operation

## Connection with Other Audio Equipment

When you connect another e.g. DVD or MP3, please connect audio input lines, and press AUX button on the remote control. Then the output of CD Player is changed to the external audio, you can press VOL-/VOL+ button on the panel or remote control.

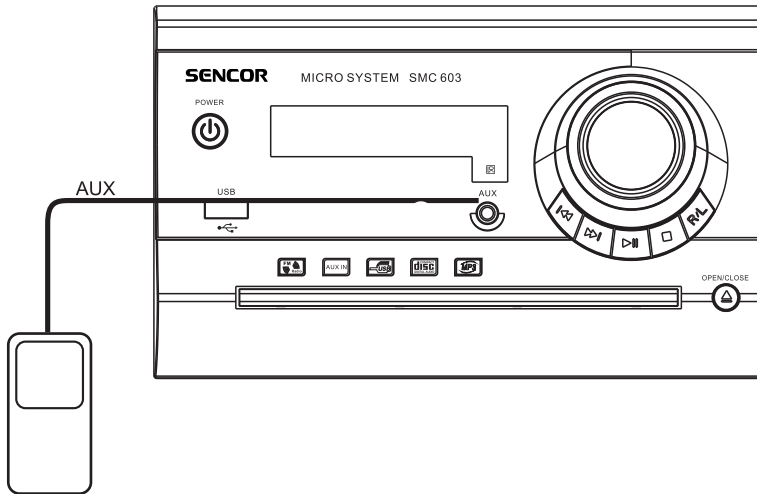

LCD DISPLAYE

LINE

# Trouble Shooting

## Trouble Shooting

Breakdown guide

Before service, please inspects the question below

Phenomenon	Cause	Measurement
No power	Disconnect the power plug	Connect the power plug right
Don't work after being energized	No Disc	Put Disc into the CD player
No sound	Not connecting to the right jack	Connecting to the right jack
	Disconnect the Audio Input lines	Connect the Audio Input lines
	Equipment connected doesn't work or Volume is 0	Make Equipment connected work or turn the volume up
CD player can't work	No disc	Put disc into the CD player
	Put disc upside down	Put disc in the right side
	Put disc out of guide slot	Put disc on the guide slot
	Disc is with stain	Clean disc
Remote control out of order	Not aiming to the receiving window	Aiming to the receiving window
	The distance between the remote control and receiving window	Operating within 7 meters
	The big obstacles in the middle of the remote control and receiving window	Put the obstacles away
	The battery of remote control run out of electricity	Replace new batteries
MP3 without sound or with noise	Disc has other modes files	Jump those files
Can't play files in USB	Can't play files in USB	Put the supported files to the USB s files
	USB is damaged	USB is damaged

# Specification

## The Main Technical Parameter

Item	Parameter
Output interface	Frequency: 2.0 sound channel independent output
FM radio	87.5 – 108 MHz
Disc supported	MP3
	CD
	CD-R, CD-RW
Audio characteristic	Frequency scope: 20-20KHZ(+/-2dB)
	Signal to noise ratio:>/80dB
	Total harmonic distortion:<0.01%
Output power (RMS)	2×5W Load 4Ω
Supply voltage	AC230V~ 50Hz
Consumption	≤ 20 W
Measurement of CD Player (MM)	L180×W205×H115
Measurement of Speakers (MM)	L110×W205×H140
Operating Temperature	-10°C ~+45°C
Operating Humidity	15-75% (without the waterdrop)
Accessories	Remote control, Manual, Warranty card, FM radio antenna

## **INSTRUCTIONS AND INFORMATION REGARDING THE DISPOSAL OF USED PACKAGING MATERIALS**

Dispose of packaging material at a public waste disposal site.

### **DISPOSAL OF USED ELECTRICAL AND ELECTRONIC APPLIANCES**



The meaning of the symbol on the product, its accessory or packaging indicates that this product shall not be treated as household waste. Please, dispose of this product at your applicable collection point for the recycling of electrical & electronic equipment waste. Alternatively in some states of the European Union or other European states you may return your products to your local retailer when buying an equivalent new product. The correct disposal of this product will help save valuable natural resources and help in preventing the potential negative impact on the environment and human health, which could be caused as a result of improper liquidation of waste. Please ask your local authorities or the nearest waste collection centre for further details. The improper disposal of this type of waste may fall subject to national regulations for fines.

#### **For business entities in the European Union**

If you wish to dispose of an electrical or electronic device, request the necessary information from your seller or supplier.

#### **Disposal in other countries outside the European Union**

If you wish to dispose of this product, request the necessary information about the correct disposal method from local government departments or from your seller.



This product meets all the basic EU regulation requirements that relate to it.

Changes to the text, design and technical specifications may occur without prior notice and we reserve the right to make these changes.