

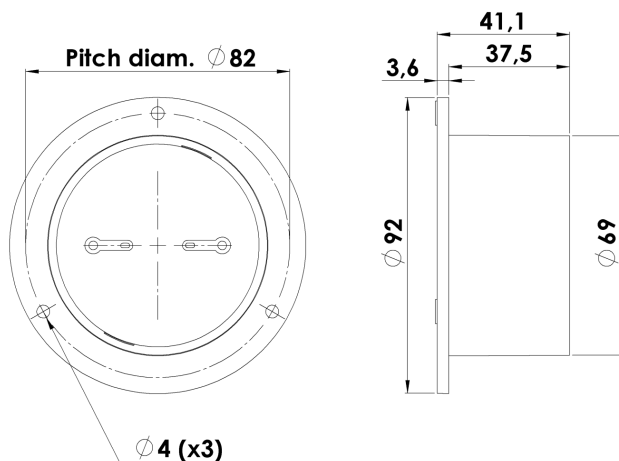

TWEETER

D2008/851200

The 3/4" tweeters D2008 and D2010 are among the many highly praised designs in Classic series. They have enjoyed success for more than 35 years. And still among the best tweeters available.



KEY FEATURES:

- 3/4" Textile Dome Diaphragm
- Dual Rear Chamber
- Wide Dispersion
- Ferro Fluid

T-S Parameters

Resonance frequency [fs]	800 Hz
Mechanical Q factor [Qms]	1.26
Electrical Q factor [Qes]	1.24
Total Q factor [Qts]	0.63
Force factor [Bl]	2.4 Tm
Mechanical resistance [Rms]	1.00 kg/s
Moving mass [Mms]	0.25 g
Suspension compliance [Cms]	0.16 mm/N
Effective diaph. diameter [D]	22 mm
Effective piston area [Sd]	3.8 cm ²
Equivalent volume [Vas]	0.01 l
Sensitivity (2.83V/1m)	88 dB
Ratio Bl/√Re	1.01 N/√W
Ratio fs/Qts	1280 Hz

Notes:

IEC specs. refer to IEC 60268-5 third edition.
All Scan-Speak products are RoHS compliant.
Data are subject to change without notice.
Datasheet updated: February 22, 2011.

Electrical Data

Nominal impedance [Zn]	8 Ω
Minimum impedance [Zmin]	6.5 Ω
Maximum impedance [Zo]	11.5 Ω
DC resistance [Re]	5.7 Ω
Voice coil inductance [Le]	0.08 mH

Power Handling

100h RMS noise test (IEC 17.1)*	90 W
Long-term max power (IEC 17.3)*	150 W

*Filter: 2. order HP Butterworth, 4 kHz

Voice Coil and Magnet Data

Voice coil diameter	19 mm
Voice coil height	3.1 mm
Voice coil layers	2
Height of gap	2 mm
Linear excursion	± 0.7 mm
Max mech. excursion	± 1.2 mm
Unit weight	0.4 kg



TWEETER

D2008/851200

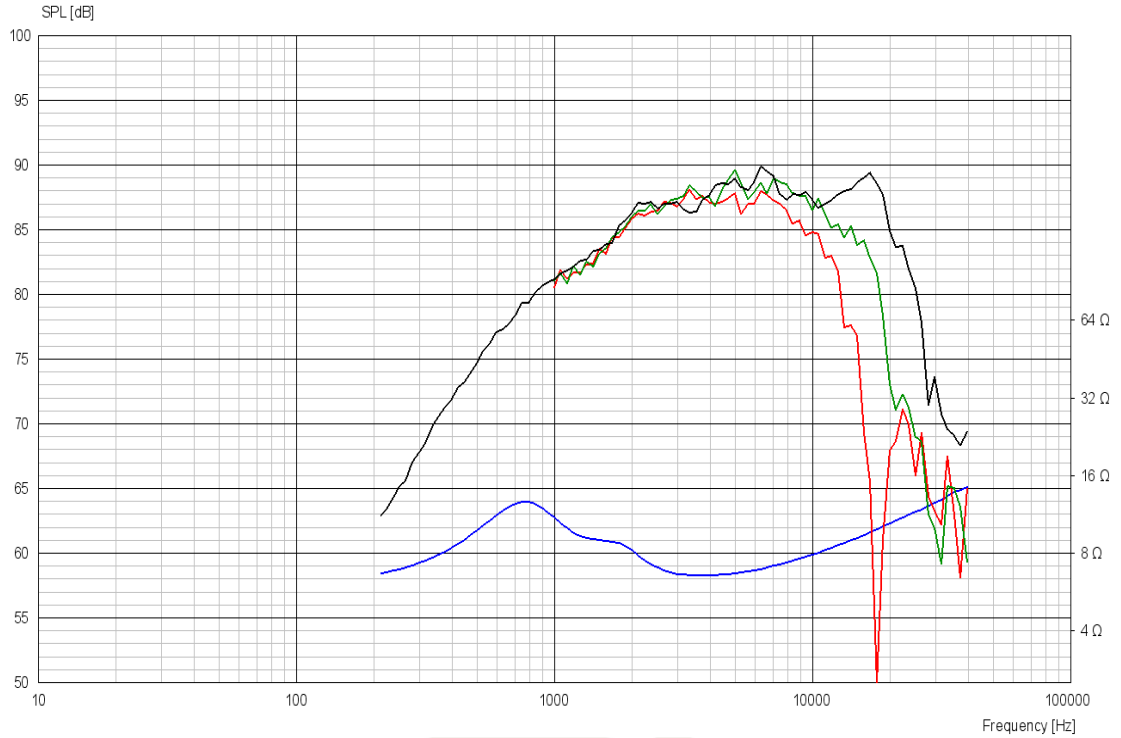

Advanced Parameters (Preliminary)



Electrical data:

Resistance [Re']	- Ω
Free inductance [Leb]	- mH
Bound inductance [Le]	- mH
Semi-inductance [Ke]	- SH
Shunt resistance [Rss]	- Ω

Mechanical Data

Force Factor [Bl]	- Tm
Moving mass [Mms]	- g
Compliance [Cms]	- mm/N
Mechanical resistance [Rms]	- kg/s
Admittance [Ams]	- mm/N