

Model Number: XXLS-P835016  
 Product Line: Peerless Platinum

Revision: Rev 1\_0  
 Date: 12-Apr-10



**Product Description:**

This 10 inch 4 ohm member of the XXLS product family has all the design features suitable for a high performance, high excursion subwoofer driver. The motor features a double ferrite magnet motor, supporting high excursion, and aluminium shorting rings and pole extenders, lowering and linearizing the inductance of the overhung voice coil. The PP cone is vented under the dust cap, to reduce air compression. The suspension system features a low-creep rubber surround, and a nomex spider, ensuring long-term reliability under high power conditions. The product also features a rigid cast aluminium basket.



**Mechanical 2D Drawing:**

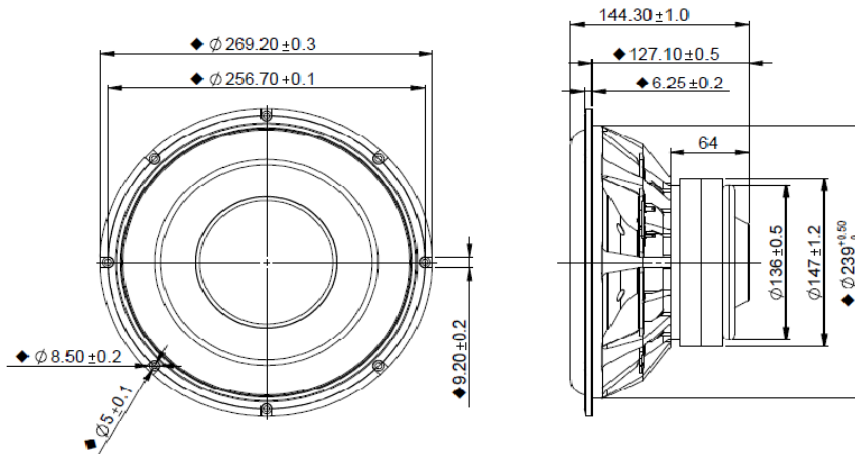

**Specifications:**

DC Resistance	$R_{evc}$	$\Omega$	2.5	5.0%	Energy Bandwidth Product	EBP	$(1/Q_{es})f_s$	68
Minimum Impedance	$Z_{min}$	$\Omega$	3.3	7.5%	Moving Mass	$M_{ms}$	g	102.1
Voice Coil Inductance	$L_e$	mH	0.51		Suspension Compliance	$C_{ms}$	um/N	365
Resonant Frequency	$f_s$	Hz	26	15.0%	Effective Cone Diameter	D	cm	21.30
Mechanical Q Factor	$Q_{ms}$	-	11.27		Effective Piston Area	$S_D$	cm <sup>2</sup>	356.3
Electrical Q Factor	$Q_{es}$	-	0.38		Equivalent Volume	$V_{as}$	L	65.093
Total Q Factor	$Q_{ts}$	-	0.37		Motor Force Factor	BL	T·m	10.36
Ratio $f_s / Q_{ts}$	F	$f_s / Q_{ts}$	70		Motor Efficiency Factor	$\beta$	$(T \cdot m^2) / \Omega$	43.74
Half Space Sensitivity @ 2.83V	$dB@2.83V/1m$	dB	89.0	+/-1.0 <sup>1</sup>	Voice Coil Former Material	$VC_{fm}$	-	GSV
Sensitivity @ 1W/1m	$1W/1m$	dB	83.8	+/-1.0 <sup>1</sup>	Voice Coil Inner Diameter	$VC_d$	mm	51.00
Rated Noise Power (IEC 2685 18.1)	P	W	100		Gap Height	Gh	mm	8.00
Test Spectrum Bandwidth	20Hz - 4kHz	12 dB/Oct			Maximum Linear Excursion	$X_{max}$	mm	12.30
					Ferrofluid Type	FF	-	N/A
					Transducer Size	-	inch	10
					Transducer Mass	-	Kg	6.14

1 - Piston Band Sensitivity Tolerance

**Frequency and Impedance Response:**

