

OCTAVE

V 70 SE

INTRODUCTION

Congratulations and thank you for choosing OCTAVE!

V 70 SE

You are now the owner of one of the world's most innovative and reliable amplifiers. Look after it, and it will provide you many years of listening pleasure.

You often hear people claim that tube amplifier design has not progressed for years. The operating principles of tubes have indeed been documented extensively and are well known to amplifier designers. Of course, the same can be said for transistor amplifiers.

However, advances in both technologies are still possible thanks to the development of innovative and improved components, our greater appreciation of the fundamental principles and, of course, deeper and more advanced insights into the interaction of amplifier and loudspeaker. With tube amplifiers in particular, a general reluctance to depart from the classic circuit designs has not done the technology any favors. Although today's loudspeakers and source equipment provide better performance than ever before, they also present greater demands on amplifiers. Modern sound reproduction equipment delivers a level of performance at a price that simply would not have been possible 20 or even 10 years ago.

These advances have been achieved through the application of the latest technological developments as they become available and affordable. OCTAVE has specialized in tube amplification for the past 25 years, during which time we have developed a number of innovative technologies that have earned us a reputation as one of the leaders in the field.

Here's wishing you many happy hours of musical pleasure!



Andreas Hofmann

CONTENTS

	Page
Introduction	3
1. Description of the V 70 SE	7
2. Safety instructions	8
2.1 Before you begin	8
2.2 Placement	9
2.3 Warranty	9
3. Getting started	10
3.1 Unpacking, package contents	10
3.2 Removing the grille	10
3.3 Installing the power tubes	11
3.4 Switching on for the first time: the soft-start feature	11
3.5 Checking the tubes (BIAS)	12
3.6 Connecting other components	12
3.7 Connection options: overview	13
4. Front panel controls	14
5. Rear panel connections	16
6. Advanced functions and connection options	18
6.1 Protection	18
6.2 Soft-Start	18
6.3 Ecomode	19
6.4 Front Channel	20
6.5 Pre-Out regulated	20
6.5.1. Using with an active subwoofer	20
6.5.2. Using in bi-amped systems	20
7. Tubes	21
7.1 Removing the grille (see 3.2)	21
7.2 Tube layout	21
7.3 BIAS measurement facility	22
7.4 Replacing the tubes	24
7.5 Running in the tubes	24
7.6 Tube service life	24
8. The programmable remote control	25
9. Optional Phono - MC/MM	25
10. Using Black Box or Super Black Box	26
10.1 The Black Box option	26
10.2 The Super Black Box option	27
11. Troubleshooting	28
11.1 Faults caused by external issues	28
11.2 Faults caused by tubes	30
12. Specifications and dimensions	32
13. Frequently Asked Questions (FAQ)	35

1. DESCRIPTION OF THE V 70 SE

The new **Octave V 70 SE** integrated amplifier is a push-pull pentode design delivering 2 x 70 W RMS output power (into 4 ohm loads). As with all Octave models, all research and development (R&D) and production has been conducted exclusively in-house, and the amplifier is comprehensively safeguarded against user error and parts wear – including catastrophic power tube failure.

The V 70 SE improves upon the V 70 predecessor, with upgrades made in the amplification stages as well as the power supply. Ultra-low leakage Tantalum electrolytic caps are now used instead of Aluminium electrolytic caps in the driver circuit. The heater voltage of the driver tubes has been precisely stabilized to reduce hum and noise that would otherwise be caused by the heater system. The heater and the supply voltage are both controlled via the power management circuit. The stabilization of the heater and power supply voltages ensures the stable, drift free operation in the mains range of +/- 15%. Every output tube in the V 70 SE is protected against over-current and other tube problems caused by aging.

BIAS Measurement

The V 70 SE is fixed **BIAS**, and utilizes external precision BIAS trim pots and LED confirmation which allows the user to readily monitor the output tubes and simply correct their BIAS individually at the front panel of the unit without the need of a micrometer let alone any special knowledge or tools – just the supplied 3 mm flat-head screwdriver.

Black Box Option

The V 70 SE is fitted with a connector for the optional Octave “**Black Box**” capacitance modules – available in normal and “Super” versions. The use of the Black Box or Super Black Box significantly increases power supply capacitance to stabilize current delivery and reduce impedance interaction of the load, thus improving dynamic range, separation, depth, soundstage size and articulation. This enables optimizing the V 70 SE in respect to the speaker, which is a tremendous benefit if the speaker is difficult to drive.

Input Section

The input section of the V 70 SE features five line level single ended Inputs with an optional internal Phono board, one balanced Input and two single ended Outputs. One is a standard record output; the other Pre-Out is a regulated preamplifier output. This output is buffered with an integrated circuit to reduce the negative influence of any connected unit (typically an active subwoofer).

The Input labeled “Front Channel” is coupled with a relay that bypasses the volume regulator. The V 70 SE functions as a stereo amplifier the when the “Front Channel” Input position is selected.

Power Management and Ecomode

The V 70 SE input and output tube heaters as well as its high-voltage rails are logic-controlled to ensure that the conduction of the output tubes as well as the input stage voltages are constantly monitored and controlled by the **Power Management System**, which serves to protect the vital internal parts (tubes, rectifier, electrolytic caps, switches, etc.) against excessive turn-on current. This increases the lifetime of not only the tubes, but all power related components as each derives benefit through this system.

The **Ecomode** serves to reduce heat and unnecessary power consumption when the unit is switched on but not in use. After 9 minutes without receiving signal, the V 70 SE Ecomode is activated, turning down the power. In this “sleep” mode, the V 70 SE draws only 20 W Idle current. Therefore, the unit produces no heat while it remains switched on. When a music signal is once again detected by the V 70 SE, the Ecomode circuit will power the unit back on, with a short warm-up/start-up delay (approximately 35 seconds) before the unit will operate.

The Ecomode also serves to increase the lifetime of the tubes, while providing an added benefit of **increased safety** allowing the V 70 SE owner a level of security against any problems when leaving the unit switched on.

2. SAFETY INSTRUCTIONS

2.1. Before you begin

Before using the V 70 SE for the first time, remove the grille and install the power tubes! (See Section 3.2 "Removing the grille"). Replace the grille before switching the V 70 SE on. Operating the amplifier without its protective grille is dangerous and not recommended.

In case of emergency: unplug the unit from the wall outlet

Never use an amplifier that is damaged or faulty. Make sure that no one can use it until it has been repaired by a qualified service technician. Ensure that there is easy access to the IEC socket and power cord.

Do not open the case

There are dangerously high voltages and hot tubes inside this equipment. To avoid a burn or the risk of electric shock, never allow anyone except qualified personnel to open the case.

Servicing and maintenance

For reasons of safety, please ensure that any servicing, repairs or other modifications to OCTAVE equipment are carried out only by a qualified technician. Always get an engineer to replace blown fuses with ones of the same type and rating. If your amplifier requires servicing, please ship or take your equipment directly to OCTAVE or to one of our authorized service centers.

Modifications to OCTAVE equipment

Use "audio grade" fuses and other power cables at your own risk. The use of such devices will void the warranty. This also applies to the use contact fluids on the tube sockets.

Explanation of the warning symbols:



The lightning flash with arrowhead symbol within an equilateral triangle is intended to alert the user to the presence of un-insulated, 'dangerous voltages' within the product's enclosure that may be sufficient to constitute a risk of electric shock to persons



The exclamation point within an equilateral triangle is intended to alert the user to important operating and maintenance instructions

Before connecting up

Make sure that the voltage of your amplifier matches your electricity supply voltage.

Grounding

This amplifier is a protection class I device (with an earth conductor). To avoid the risk of electric shock in the event of a fault, the unit must be grounded. To do this, use the power cable supplied with the amplifier.

2. SAFETY INSTRUCTIONS

2.2. Placement

1. Location

OCTAVE equipment is designed strictly for use in a dry domestic environment. Do not use it in the open air or in damp environments!

Never place plants or liquid-filled containers on your OCTAVE equipment. Take care to avoid dropping objects or spilling liquids into the case. Should this happen, remove the mains plug immediately and have your amplifier checked by a qualified service technician.

Condensation may form if the amplifier is taken from a cold environment into a warm one. If you do this, wait until the amplifier has reached room temperature and is dry before switching it on.

Avoid installing the unit close to sources of heat such as radiators or anywhere that may be in direct sunlight.

Do not operate the unit near flammable materials, gases or vapors. Avoid areas where there may be heavy accumulations of dust or where the unit may be subject to mechanical vibration.

Place your OCTAVE amplifier on a stable, level surface.

2. Grille

Never operate the amplifier without the protective grille in place.

3. Ventilation

Make sure that your amplifier has an adequate flow of air around it. If you intend to install your equipment into a cupboard or on a wall shelf unit, ensure that there is at least a ten centimeter (4 inch) gap between the ventilation slots and the walls all around the amplifier. The rear panel of cupboards should have ventilation holes to prevent heat build up. Do not rest the equipment on a soft surface such as carpet or foam sheeting.

2.3. Warranty

OCTAVE can only guarantee the safety, reliability and performance of this unit if modifications and repairs are carried out by specialized personnel and when the amplifier is operated in accordance with the instructions contained in this manual.

3. GETTING STARTED

3.1. Unpack and check the contents of the box.

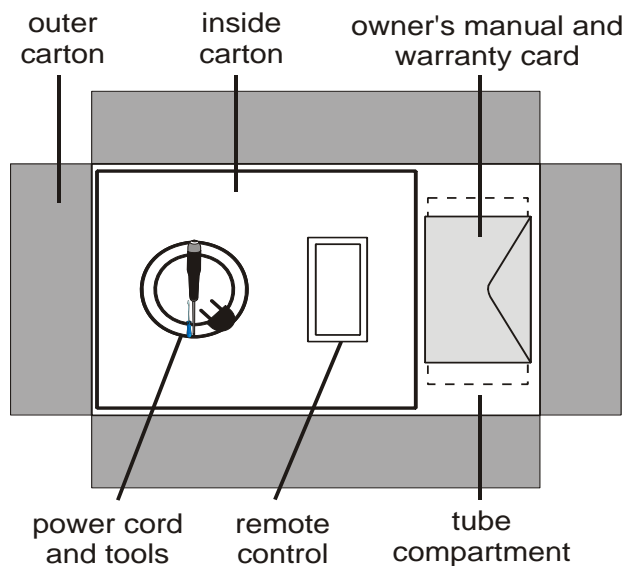

Package contents standard

- V 70 SE serial equipped with 6550 C power tubes
- 5 power tubes packed separately
- Power cord
- Remote control with owner's manual
- 2 screwdrivers: 1 x 2 mm flat-bladed screwdriver for adjusting the BIAS
1 x 2,5 mm Allen key for removing the cover
- Owner's manual with warranty card

3.2. Removing the grille

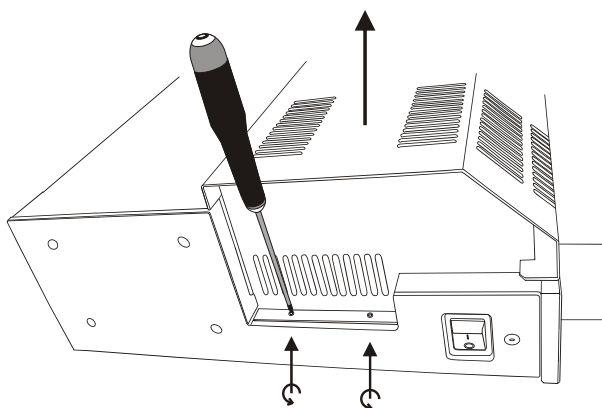

- 1) For your own safety, make sure that the amplifier is not connected to power outlet.
- 2) Completely remove the 4 hexagonal screws using the Allan key supplied. There are 2 screws on each side.
- 3) Carefully pull the grille upward to remove.

3. GETTING STARTED

3.3. Installing the power tubes

The power tubes are in a separate box in the tube compartment

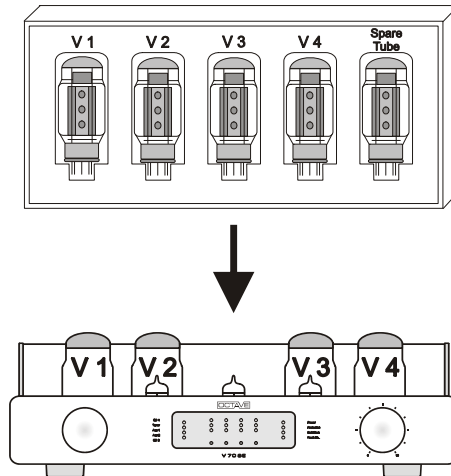

Insert the power tubes into their sockets as shown on the tube layout. Ensure that you correctly locate the anti-rotation lug on each of the tubes.

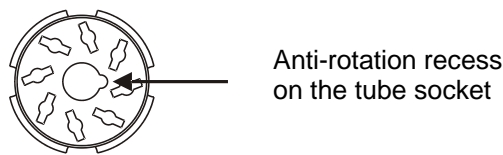

3.4. Switching on for the first time – the Soft-Start feature

The V 70 SE is equipped with a multi-stage Soft-Start-Turn-On protection circuit which extends component as well as tube life considerably by protecting against stress caused by typical high inrush currents during switch on.

- 1) Check that the Ecomode switch on the rear panel is in the "Eco off" position
- 2) Connect the V 70 SE to the mains. (On new units, this switch is set to "off" at the factory).

Ecomode



Eco off Eco on Amp off

- 3) Switch on the V 70 SE using the amplifier's mains power on/off switch. Some LEDs will illuminate, depending on the position of the input rotary switch. In any case the **Power LED** (indicates that the unit is switched on) and the **Soft-Start LED** will be lit. The **Soft-Start LED** will extinguish a **minute later** once the unit has booted up. The V70SE is now ready for work.

3. GETTING STARTED

3.5. Checking the power tubes – setting the BIAS

- 4) Turn the mode selector knob clockwise to position 6 = BIAS. The input LEDs will extinguish.

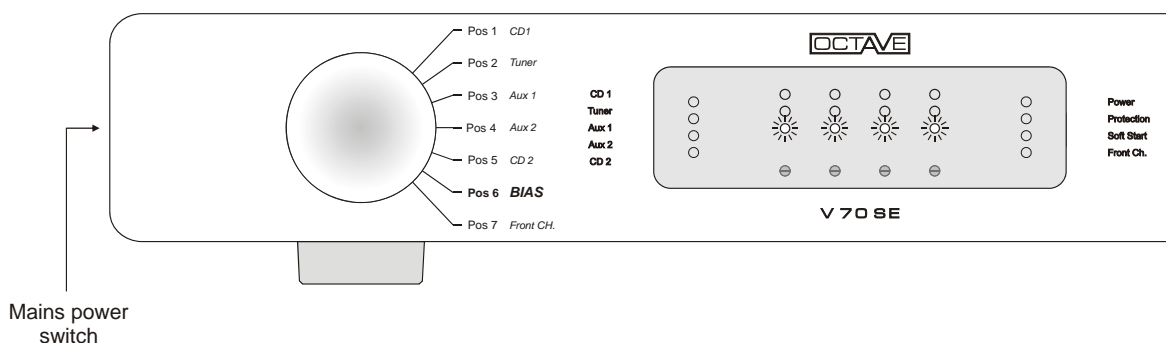

- 5) Five LEDs will now illuminate: The power LED and the 4 BIAS LEDs in the centre of the display, one for each power tube. If the amplifier is still cold, the LEDs will initially illuminate "yellow".

Please wait five to ten minutes:

Please don't turn the BIAS regulators until the Soft-Start-LED is extinguished.

(Because the tubes are still cold you would adjust the wrong BIAS)

After an additional 5 to 10 minutes, the BIAS control LEDs will change from yellow to green.

This indicates the correct bias and the unit is ready. If you notice any irregularity in the display please refer to chapter 7.3.

3.6. Connecting other components to the V 70 SE

- 1) Be sure to switch off the V 70 SE again!
- 2) Connect the other components in your system to the appropriate sockets on the rear of the V 70 SE. (See chapter 5 "Rear panel connections". See also chapter 3.7. "Connection options: overview")
- 3) Check that the switch positions on the front and rear of the amplifier are in their recommended settings.
- 4) Switch on the V 70 SE using the on/off switch and wait until the Soft-Start LED extinguishes. Now you can play music.

3. GETTING STARTED

3.7. Connection options: overview

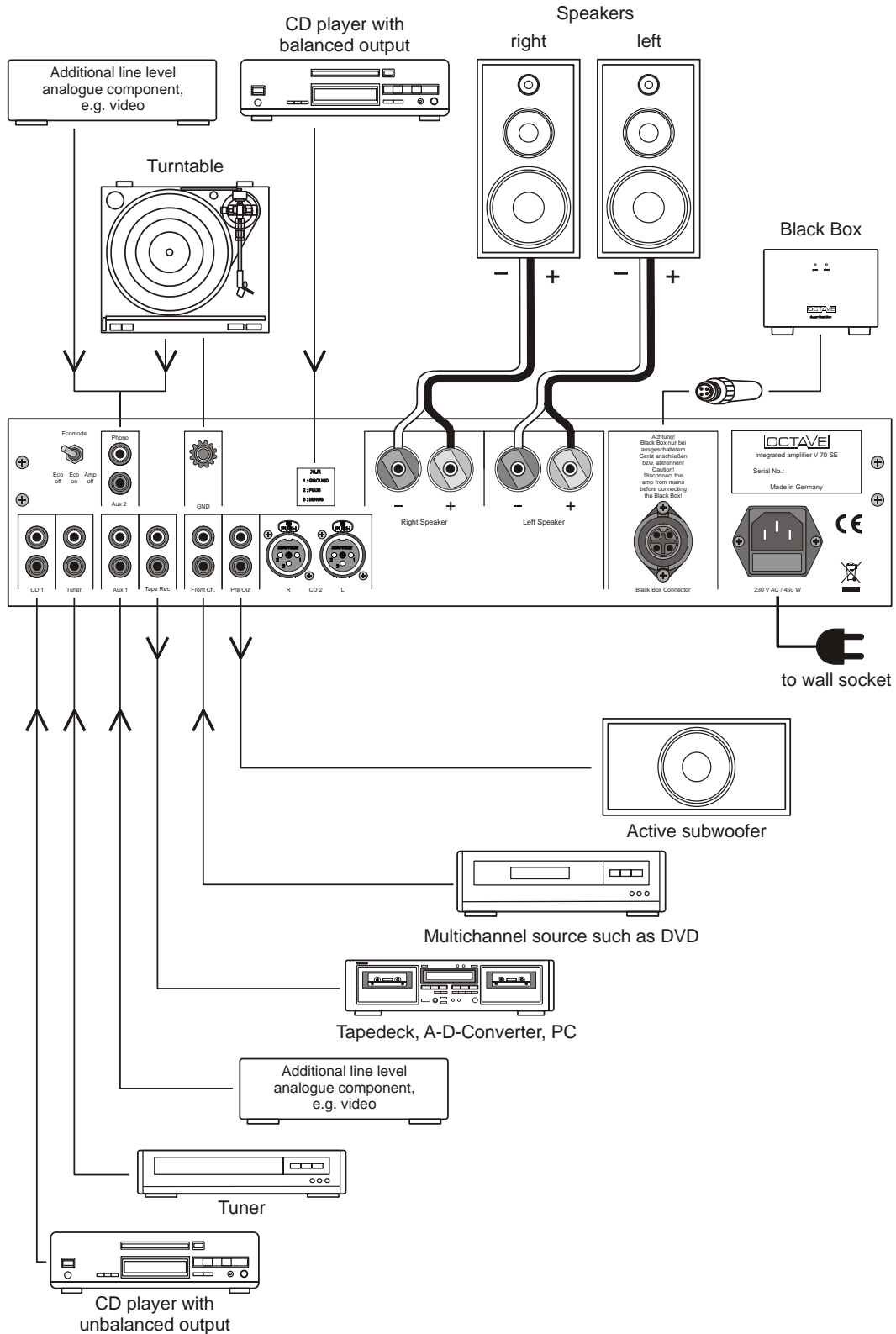

4. CONTROLS – the front panel

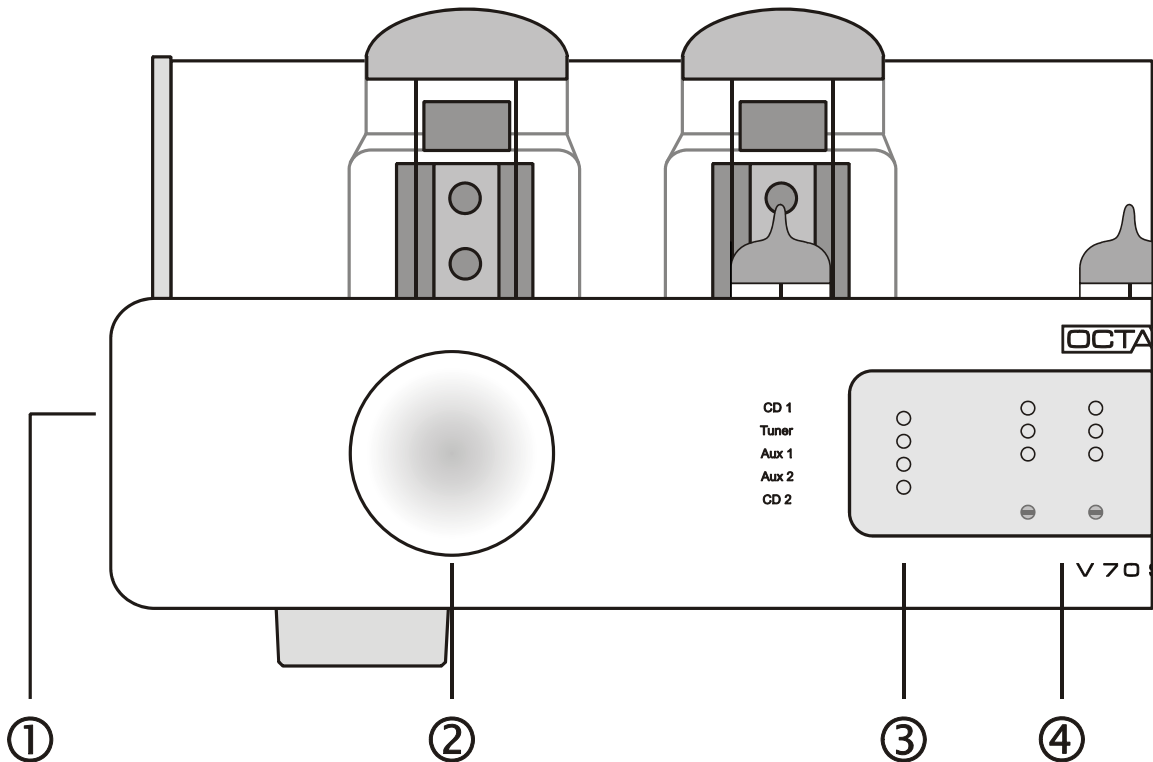

- ① **Power switch** 0 = off; 1 = on. Power LED and Soft-Start LED illuminate. The Soft-Start LED extinguishes after the start-up period of 50 seconds.
- ② **Input selector** This is used to select the desired input signal. A green LED indicates the selected input on the display.
- Pos 1: **CD 1** RCA line level input for CD, SACD and similar
- Pos 2: **Tuner** RCA line level input for tuner, etc.
- Pos 3: **Aux 1** RCA line level input for video, etc.
- Pos 4: **Aux 2** RCA line level input for video, etc.
- Pos 5: **CD 2** XLR line level input for CD, SACD or similar.
- Pos 6: The electronic **BIAS** measurement system is activated (see chap. 7.3).
- Pos 7: **Front Ch.** Multichannel input. In this mode, the V 70 SE functions as a two-channel power amplifier. The volume control is bypassed. (See chap. 6.4)
The record output is switched off in this position.
- ③ **LED indicators** Indicating the active input
- ④ **BIAS adjustment** BIAS regulators and corresponding LED array for each power tube

4. CONTROLS – the front panel

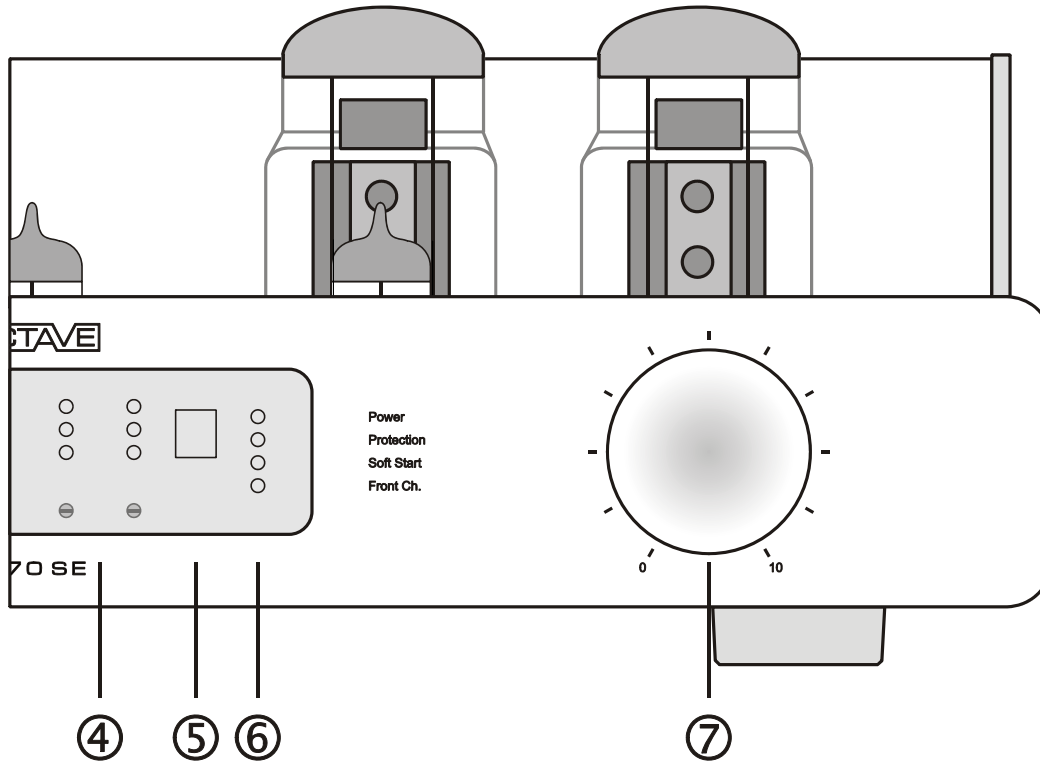

- | | | | | | | | | | | |
|------------|--|---|-------|---|------------|--|------------|--|-----------|---|
| ④ | BIAS adjustment | BIAS regulators and corresponding LED array for each power tube. | | | | | | | | |
| ⑤ | Remote control receiver | To ensure optimum operation of the IR remote control, do not cover this window. | | | | | | | | |
| ⑥ | Status indicators | <table border="0"> <tr> <td style="vertical-align: top;">Power</td> <td style="vertical-align: top;">Indicates that the unit is switched on.</td> </tr> <tr> <td style="vertical-align: top;">Protection</td> <td style="vertical-align: top;">Red LED lights up when the electronic protection system has switched off the amplifier in response to an amplifier fault (see chapter 6.1.).</td> </tr> <tr> <td style="vertical-align: top;">Soft-start</td> <td style="vertical-align: top;">Lights up during the soft-start process immediately after switch-on. This LED extinguishes after about 1 minute when soft-start has been completed (see chapter 6.2.).</td> </tr> <tr> <td style="vertical-align: top;">Front Ch.</td> <td style="vertical-align: top;">Illuminates when multichannel-bypass function is selected (see chapter 6.4.).</td> </tr> </table> | Power | Indicates that the unit is switched on. | Protection | Red LED lights up when the electronic protection system has switched off the amplifier in response to an amplifier fault (see chapter 6.1.). | Soft-start | Lights up during the soft-start process immediately after switch-on. This LED extinguishes after about 1 minute when soft-start has been completed (see chapter 6.2.). | Front Ch. | Illuminates when multichannel-bypass function is selected (see chapter 6.4.). |
| Power | Indicates that the unit is switched on. | | | | | | | | | |
| Protection | Red LED lights up when the electronic protection system has switched off the amplifier in response to an amplifier fault (see chapter 6.1.). | | | | | | | | | |
| Soft-start | Lights up during the soft-start process immediately after switch-on. This LED extinguishes after about 1 minute when soft-start has been completed (see chapter 6.2.). | | | | | | | | | |
| Front Ch. | Illuminates when multichannel-bypass function is selected (see chapter 6.4.). | | | | | | | | | |
| ⑦ | Volume control | Remote controlled motorized potentiometer. | | | | | | | | |

6. CONNECTIONS – the rear panel

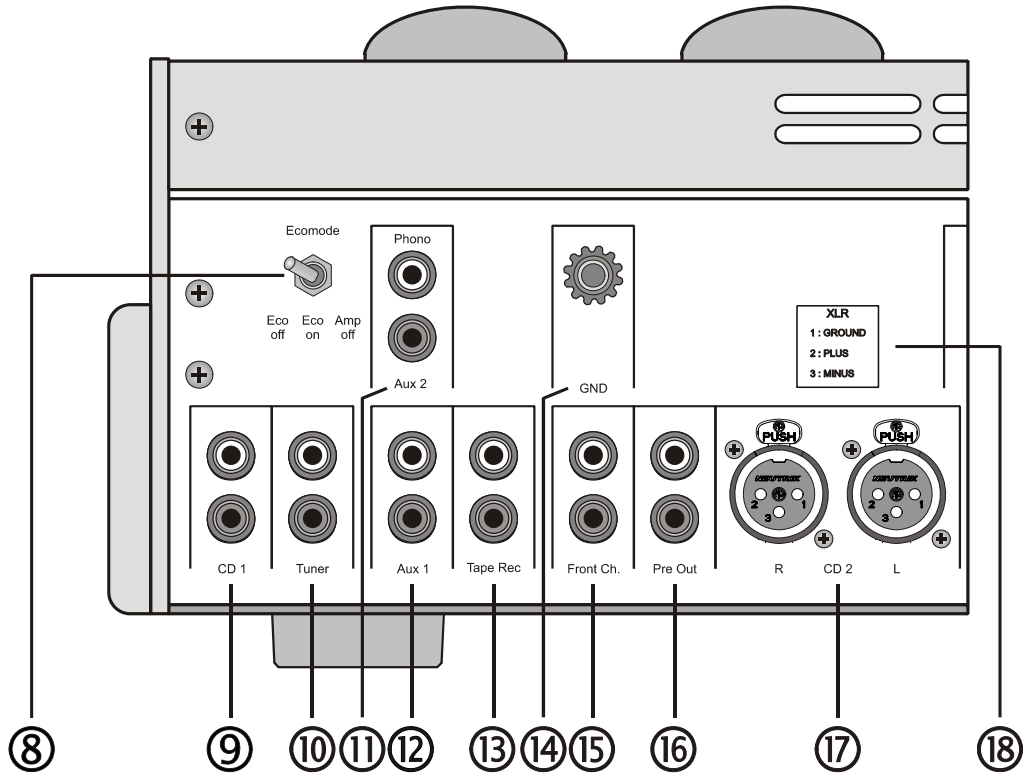

⑧ Ecomode

Ecomode



Eco off Eco on Amp off

Eco off: Ecomode automatic is off.
 Eco on: Ecomode automatic is on.
 Amp off: The power stage of the amplifier is off (see chap. 6.3.).

⑨ CD 1

CD line level input, RCA.

⑩ Tuner

Tuner line level input, RCA.

⑪ AUX 2

RCA line level input for Video etc, or MM/MC input with Phono option.

⑫ AUX 1

RCA line level input for Video, etc.

⑬ Tape rec

Record output for tape or DAT.

⑭ GND

Ground connector for Turntable.

⑮ Front Channel

Input for the front channel of a multichannel receiver / DVD player (see chapter 6.4).

⑯ Pre Out

Regulated preamp output for active subwoofer, etc. (see chapter 6.5.).

⑰ CD 2

CD line level input, XLR.

⑱

Pin configuration for XLR connectors.

6. CONNECTIONS – the rear panel

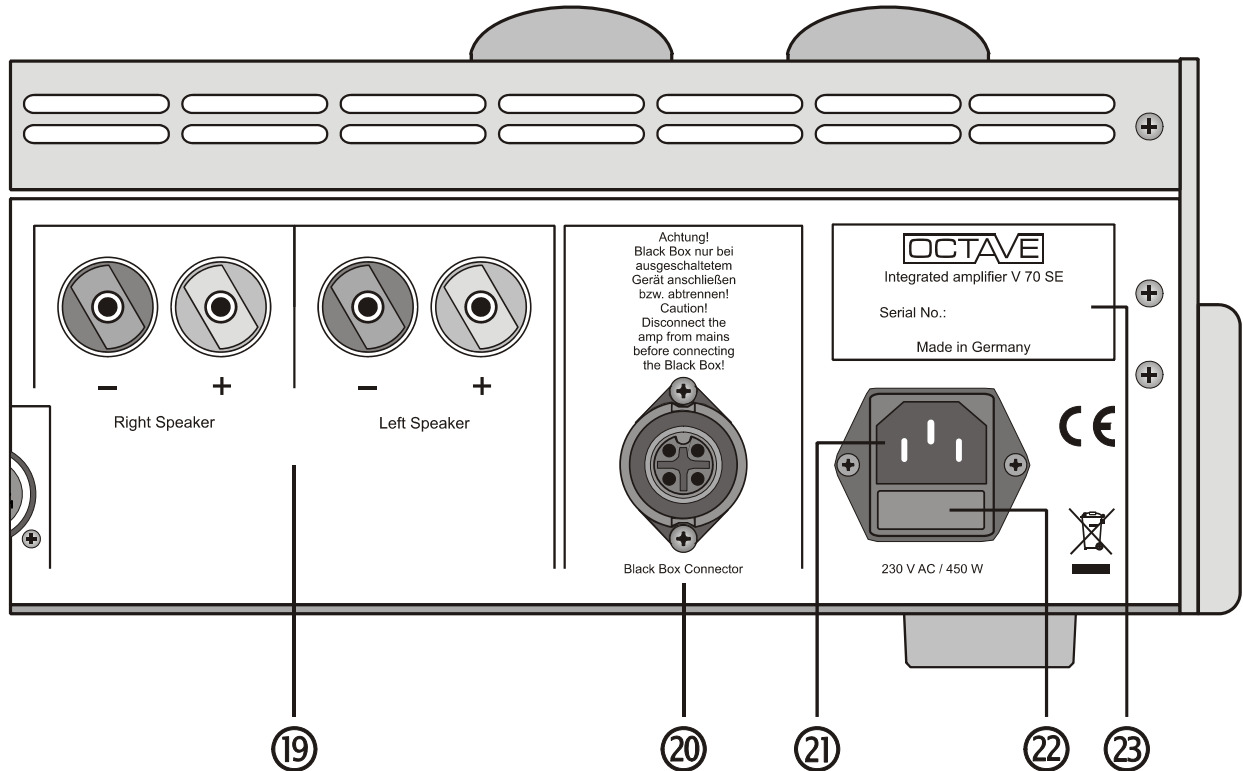

19 Loudspeaker outputs

Speaker connection terminals.
Red = positive terminal, Black = negative terminal.
The speaker negative terminal is connected to ground.

20 (Super) Black Box connection



The (Super) Black Box is an outboard power supply capacitance upgrade for the power amplifier section (see chapter 10).
You should switch off the V 70 SE using the power switch before connecting and disconnecting the Black Box!

21 AC supply socket

IEC socket with integrated fuse holder.
The fuse is located in a pullout compartment underneath the socket. You can open the fuse compartment after removing the plug.

22 Fuse

For 230/240V: 3.15A slow-blow H (5 x 20 mm).
For 115/240V: 5A slow-blow H (5 x 20 mm).
For 100V: 6.3 A slow-blow H (5 x 20 mm).

23 Model identification plate

Model and serial number.

6. ADVANCED FUNCTIONS

6.1. Protection

The V 70 SE features a comprehensive electronic monitoring and protection system. This system will automatically switch off the V 70 SE in case of a fault occurring in the power section.

The protection system has been designed to keep the unit safe from the consequences of overloads of any kind and to protect the output tubes from current surges.

The red "Protection" LED lights up in [No. 6, chapter 4] to indicate that the protection system has tripped.



The amplifier will not play music once the protection system has tripped and you will not be able to check or adjust the BIAS setting.

The BIAS LEDs will show "yellow" for each of the four output tubes.

If a Black Box or a Super Black Box is connected to the V 70 SE, the front panel (operate) LED of the Black Box / Super Black Box will go out. If the Super Black Box is connected, tripping the protection system will automatically activate the discharge circuit of the (Super) Black Box (see chapter 10).

The following conditions can cause the protection system to trip:

- Overdriving the V 70 SE to excessive levels or with excessive levels of low frequency.
- A speaker cable short circuit while the speakers are being driven at high listening levels.
- A fault in one or more of the output tubes.
- A fault in one of the preamp tubes which overloads the affected channel.

Once the protection system has cut in, the only way you can turn the V 70 SE back on is to turn the on/off switch off and then on again. Allow the unit two minutes to cool down before switching it back on. If possible, identify and eliminate the cause of the problem (see chapter 11 "Troubleshooting").

If it is not clear what has caused the protection system to trip, we recommend that you check the BIAS before attempting to use the amplifier again. Tube faults can often result in widely varying BIAS settings. When these settings exceed a particular value they can cause the protection system to trip.

6.2. Soft-Start

The V 70 SE input and output tube heaters as well as its high-voltage rails are logic controlled to ensure that the conduction of the output tubes as well as input stage voltages are constantly monitored and controlled by the **Power Management system** to protect the vital internal parts (tubes, rectifier, electrolytic caps, switches, etc.) against excessive turn-on current. This increases the lifetime not only of the tubes, but also the caps, while all power related components derive benefit through this system.

The Soft-Start is always activated within the first 60 seconds after the unit is switched on. During this time you cannot listen. The Soft-Start delay is indicated with the Soft-Start-LED.



During the Soft-Start-phase, adjusting the BIAS is not possible.

6. ADVANCED FUNCTIONS

6.3. Ecomode

The **Ecomode** serves to reduce heat and unnecessary power consumption when the unit is switched on but not in use. After 9 minutes without receiving signal, the V 70 SE Ecomode is activated, turning down the power. In this “sleep” mode, the V 70 SE draws less than 20 W Idle current. Therefore the running unit produces no heat, because the heater voltage and the high voltage for the power amplifier section are switched off. When the music signal is once again sensed by the V 70 SE, the Ecomode circuit will turn the unit back on, with a warm-up/start-up delay of approximately 35 seconds before the unit will operate.

The Ecomode also serves to increase the lifetime of the tubes, while having an added benefit of **improved safety** allowing the V 70 SE owner a level of security against any problems when leaving the unit powered on. The Ecomode is a safety and energy-saving feature that automatically switches off the amplifier's tube circuitry during breaks of more than 9 minutes.

Ecomode reduces the overall power consumption of the amplifier to under 20W, compared with 140W in normal operation. When detecting a signal, the V 70 SE reactivates automatically and is ready for use again within 30 seconds.

Rear panel switch settings

Ecomode



Eco off Eco on Amp off

Eco off: The Ecomode electronic is off, the amplifier is on.

Eco on: The Ecomode electronic is activated. Ecomode is signal-actuated; after a 9-minute silence, Ecomode switches in automatically. The soft-start LED [6] indicates that the Ecomode was turning down the unit. As soon as the Ecomode circuit detects the presence of an input signal (from the CD player, for example) it will automatically power the V 70 SE up. The process takes approximately 30 seconds, after which time the soft-start LED will extinguish to show that the V 70 SE is ready for use.

Note:

If you switch on the V 70 SE with Ecomode active, it will go through the start procedure. If it fails to detect a music signal, it will shut down after 10 minutes.

As well as saving electricity, Ecomode has a number of other advantages:

- Extended tube life
- Reduced heating of the whole unit
- Increased passive safety if the unit is left on by mistake

Ecomode is not the same as standby, however, because certain sections of the amplifier remain on.

Important!

You cannot adjust the BIAS in Ecomode once the amplifier has powered down! Powered down during Ecomode is indicated by the soft-start-LED.

Amp off: The power section of the amplifier is off.
This setting is recommended if only the input section is in use. For example, this would make sense by using the V 70 SE as a distributor for a signal for an external headphone amplifier perhaps. Record-Out and regulated Pre-Out is active. The signal is not activating the Ecomode to turn on the power section.

6. ADVANCED FUNCTIONS

6.4. Front Channel Input - Bypass function

The Input labeled "Front Channel" is coupled with a relay that bypasses the volume regulator. In the "Front Channel" selector position, the V 70 SE functions as a stereo amplifier.

The signal of the front channel input is not available on the record output.

6.5. Regulated preamplifier output – Pre-Out

6.5.1. Using with a subwoofer

The regulated preamplifier output is most commonly used to drive an active subwoofer. The Pre Out is decoupled via a separate buffer to prevent the V 70 SE against the load of the subwoofer. The input impedance of the subwoofer is therefore non-critical.

The Pre Out does not have a separate muting function to prevent switch-on or switch-off plops from the V 70 SE. This is not normally needed, however, since the active crossover in the subwoofer electronics will block unwanted DC and low frequency signals.

6.5.2. Using the V 70 SE in bi-amped systems

Another option provided by the adjustable Pre Out is Bi-amping via the V 70 SE's internal preamplifier. The V 70 SE would ideally handle the mid/high portion of a bi-amping setup, using a second power amplifier fitted with its own volume control to take care of the bass. In this configuration, switch-on/switch-off noises from the Pre Out may prove to be a problem. The best way to deal with this is to make sure the you first switch on the V 70 SE, then the external power amplifier - and when switching the units off do such in the reverse order.

If you do not have a power amplifier with a separate volume control, you should match the input sensitivities (or gain) of each amplifier. You will normally find the gain listed in dB in the amplifier's specification. The figures for each power amplifier should be within 2 dB of each other.

The ideal gain of the external power amplifier is 25 dB / +/-2 dB.

Configuration of the V 70 SE in bi-amped systems

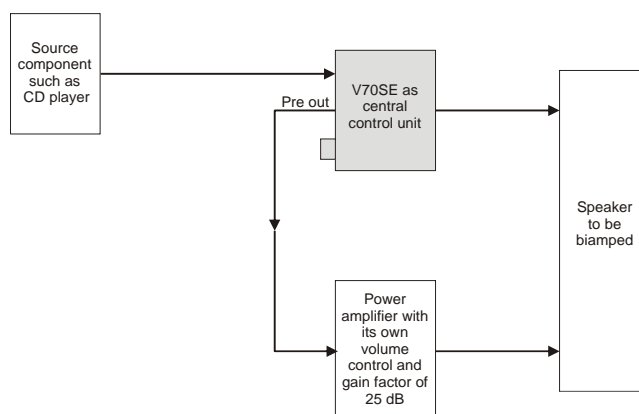

7. TUBES

7.1. Removing the grille

See chapter 3.2.

7.2. Tube layout

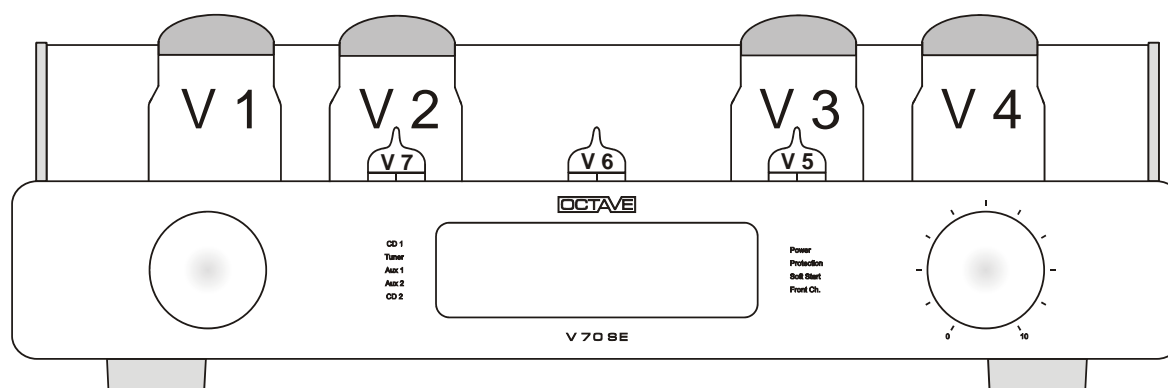

Output tubes: V1 - V4: 6550 C standard
 V1 + V2 left channel
 V3 + V4 right channel

Driver tubes: V5 ECC83 (12 AX 7)
 V6 + V7 ECC81 (E 81CC, 12AT 7) alternatively 2 x ECC 82

The pentode output stage topology of the V 70 SE makes it possible to use of a variety of output tubes. Because the specification limits of the tubes are never exceeded in pentode mode, weaker output tubes may also be considered. This is facilitated by the option of setting the BIAS current to two different values: low and high.

Output tubes can be divided into two broad classes – classic pentode output tubes for medium power amplifiers and modern, high performance pentodes for power amplifiers up to 80W output.

Low BIAS output tubes include: 6L6, KT 66, EL 34, KT 77, 5881, 6 CA 7.
 High BIAS output tubes include: 6550, KT 88, KT 90, KT 100.

Note: Low BIAS tubes will not allow you to achieve the maximum output of the V 70 SE. We do not recommend using them with low efficiency or low impedance loudspeakers.

Some tubes will fit into the sockets but will still not work with the V 70 SE – such as the EL 509 / 519, for example.

7. TUBES

7.3. THE BIAS MEASUREMENT SYSTEM

The BIAS measurement facility makes it easy for you to check and adjust the idle current of the output tubes. Getting the BIAS setting right for all four tubes is critical for both the sound of the power amplifier section and for the service life of the tubes. This feature guarantees consistent sound quality over the entire lifetime of the output tubes.

That is why we have built this BIAS measurement facility into the V 70 SE – to allow you, the user, to carry out the adjustment yourself without the need for test equipment. The use of precision op amps makes it possible for you to set the BIAS to an **accuracy** within 0.3%, making it superior to any other method.

Using selected output tubes only makes sense if the idle current is adjusted accurately, as is clearly shown in Fig. 1 Technical Data.

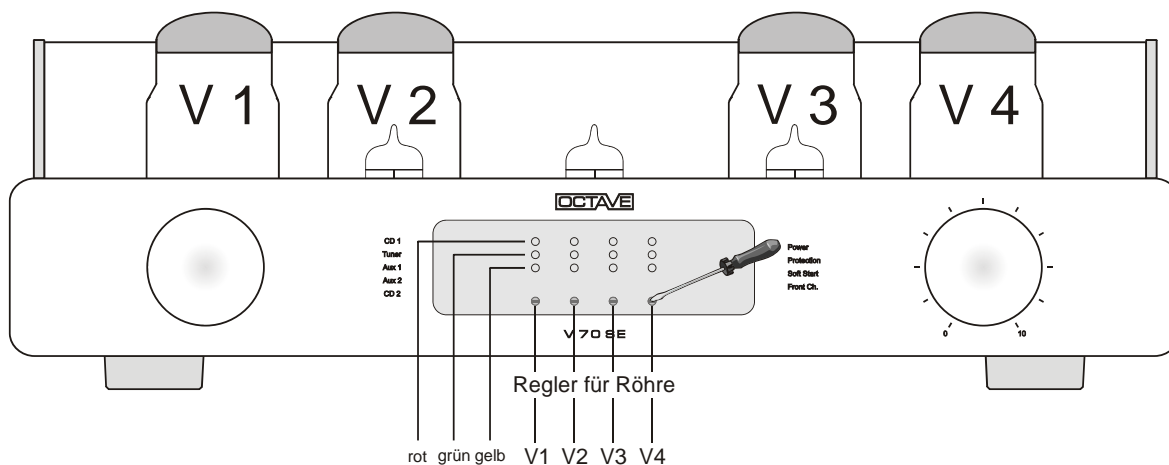

How to set the BIAS

Turn the Input selector knob [2] clockwise to the BIAS position to activate the measurement circuit. (pos. 6); Signal/input selection is disabled. The 3 LEDs above each screw in the display panel show whether the BIAS setting is too low, correct, or too high. Use the small screwdriver supplied to adjust the BIAS.

To increase the BIAS current to each output tube, turn the screwdriver clockwise.

The adjusting screws are fully insulated. There is no risk of electric shock and the adjustment procedure is completely safe.

The LED display:

Red LED only	Setting is too high
Green + red LED	Setting is OK for KT 88 6550, etc. = high BIAS
Green LED only	Setting is OK.
Yellow + green LED	Setting is OK for EL 34, 6L6, KT 66, etc. = low BIAS
Yellow LED	Setting is too low

7. TUBES

There is an upper adjustment limit to the "high" BIAS setting, which is indicated by the green and red LEDs lighting up at the same time, and a lower limit to the "low setting, where the yellow and green LEDs light up. The lower limit should be used with "smaller" output tubes such as the EL 34 and similar. The upper value, which provides a higher BIAS current for the output tubes, should be used with the more powerful tube types such as the KT 88, KT100, 6550, KT 90. (See chapter 7.2.) These tube types do not have to be operated at a high BIAS setting; they will work perfectly well on the low setting. However, certain loudspeakers may benefit from the higher BIAS current, as it will increase the damping factor and provide slightly better control of the movement of the speakers.

LED graphs

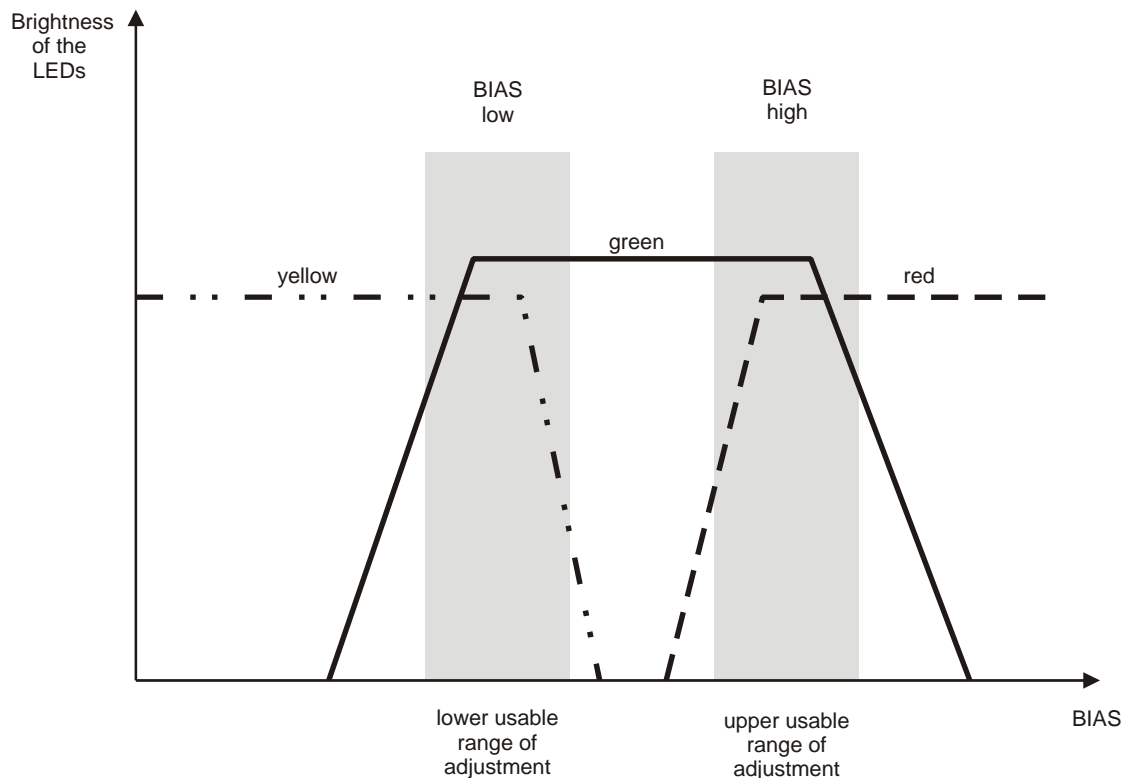

Important note:

If the protection system is activated, adjusting the BIAS is impossible. The BIAS display always indicates yellow. Please do not turn the regulators in this mode (see chapter 6.1.)

7. TUBES



7.4. Replacing the tubes

- **Driver tubes**

Replacement driver tubes require no adjustment.

- **Output tubes**

General procedure:

1. Switch off the amplifier and allow it to cool down for 10 minutes. Remove the old tubes and fit the new ones.
2.  Before you switch the amplifier back on, turn all BIAS adjustment screws (see chapter 7.3) counter clockwise (this greatly reduces the anode current). You will hear a click when the screws reach the minimum setting. These screws are three-turn potentiometers, i.e. it takes three revolutions to go from the maximum to the minimum setting.
3. Switch on the amplifier and turn the mode selector switch [No. 2, chapter 4] to the BIAS position. Following the Soft-Start phase, all 4 "minus" LEDs (yellow) will illuminate. If from this point of time any of the LEDs are green or red, this indicates a faulty tube that must be replaced. After a 10-minute warm-up period, set the BIAS as explained in chapter 7.3.
- 3.1.  Original Octave tubes. **There is no need to burn in original Octave replacement tubes. Allow the tubes 10 minutes to warm up and adjust them to the appropriate setting for the tube type.**
- 3.2. New, untested output tubes should be allowed a longer warm up period. You should adjust these tubes after about 20 minutes.

7.5. Running in

All OCTAVE equipment is subject to a 48-hour soak test at the factory to burn in the tubes. The tubes are preselected for use in each particular model.

New tubes can take up to three months to run in and start sounding their best.

Daily use is beneficial in speeding up this process but is not mandatory. Continuous operation does very little to help reduce the running-in time and is therefore ***not*** recommended.

7.6. Tube service life

- Thanks to the protection circuits and soft-start electronics, the output tubes in your amplifier should achieve a service life of up to 3 - 5 years.
- Driver tubes can be used for 10 years or even longer.
- Because tubes have different service lives, you will never have to renew the entire tube complement at the same time. The facility for setting the BIAS for each output tube individually makes it unnecessary to use matched sets of output tubes. You can replace output tubes individually if you wish.
- Some tubes require a long time (up to 300 hours) to achieve their optimum sound quality. Depending on how long the tubes have been stored, it may be necessary to adjust the BIAS several times in the first two to three weeks after installing them.

8. THE PROGRAMMABLE REMOTE CONTROL

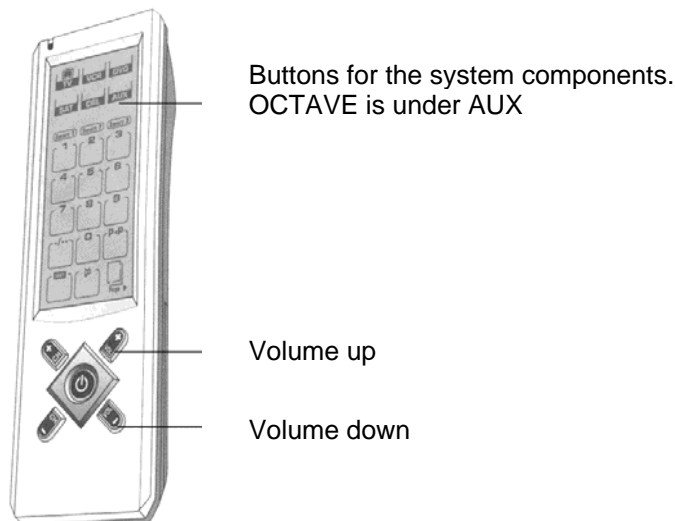

Select the V 70 SE by pressing the AUX button once. You can now adjust the volume by repeatedly pressing the VOL + and VOL - buttons. You will find more detailed information on programming the remote control in the separate operating instructions.

9. PHONO (MC / MM) OPTION

A MM or MC Phono board is available as an option for the V 70 SE. This additional board is connected internally to the phono input. When the board is installed, this input can no longer be used as a line level input. The phono preamplifier incorporates active RIAA equalization with an active, 2nd order subsonic filter. The phono preamplifier uses semiconductor technology throughout.

The subsonic filter suppresses undesirable low frequency signals in the sub-audio range caused by warped disks and pickup/tone arm resonances. The inverting active equalization guarantees absolutely natural tonality of the phono preamplifier. Traditional equalization topologies lacking effective subsonic filtering and carrying out the equalization within the negative feedback loop can never achieve better than average sound quality, particularly as subsonic interference will cause substandard reproduction of the lower registers.

Two phono boards are available, one for MC and one for MM. Installation is straightforward and can be carried out by your authorized retailer or a specialist workshop.

The MC board is recommended without reservation for use with virtually all MC systems and has been optimized for both low and medium output systems. The MM board has a standard input impedance and is thus suitable for all high output MC and MM systems.

Specification:

Input impedance:	MC 150 ohm, MM 47k ohm
Signal-to-noise ratio	MC 73 dB, MM 85 dB
Input sensitivity	MC 0.5 mV, MM 4 mV
Subsonic filter	-12 dB/octave, 20 Hz cut off frequency

10. USING THE (SUPER) BLACK BOX

Description

OCTAVE, with the Black Box technology, offers an instrument for optimizing the OCTAVE amplifier in respect to the speaker. This flexibility is a unique feature of the OCTAVE brand.

The dynamic and tonal stability of an amplifier is strongly dependent upon the stability and capacity of the power supply, therefore the Black Box and Super Black Box were developed as external upgrades to the OCTAVE amplifiers' power supply storage capacitors by increasing their capacitance by a factor of 4 (Black Box) or 10 (Super Black Box), respectively. This is a tremendous benefit if the speaker is difficult to drive. Loudspeaker efficiency is made less critical, while the amplifier is enabled to handle speakers with minimum impedances as low as 2 ohms.

The power supply capacitance increase realized via use of the Black Box or Super Black Box stabilizes current delivery and reduces the impedance interaction of the load. This improves dynamic range, separation, depth, soundstage size and articulation, rendering the musical reproduction clearer throughout the entire frequency range. The amplifier remains unaffected by mains variations and interferences due to the noise filtering characteristics of the capacitors

12.1. The Black Box option

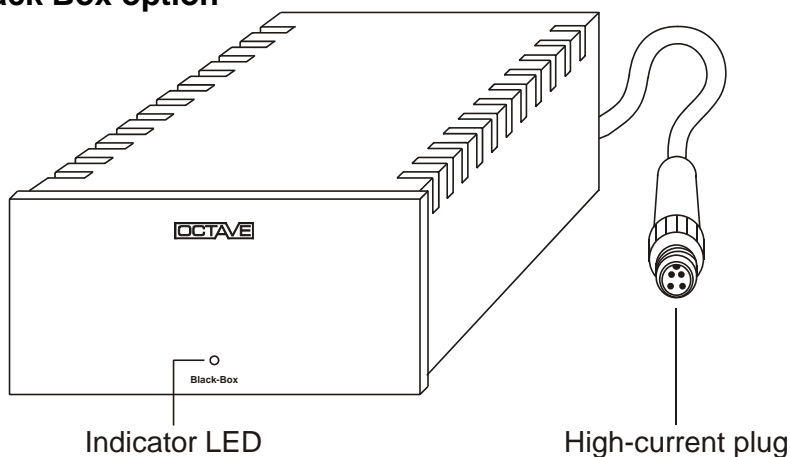

The LED illuminates continuously when the power amplifier is on.

The LED goes out when the protection circuitry trips. This is normal, as the protection circuitry cuts the power to the amplifier.

Specification

Dimensions	170 X 97 X 257 mm (W x H x D)
Weight	2.5 kg
Connection cable	Length: 70 cm. Longer lengths are available upon request.

Connecting to the amplifier



- Important! Before connecting the Black Box, switch **off** the unit using **the power switch and wait for 1 minute**.

When inserting the connector, guide the anti-rotation lug carefully into the mating recess in the socket.



- When you switch the amplifier on, the LED on the front panel of the Black Box will illuminate.

Note: The LED on the Black Box goes off when the amplifier's electronic protection circuitry is activated, as the protection circuitry shuts off the power to the amplifier.

- Should you wish to disconnect the Black Box, switch off the amplifier first and **wait until the LED on the Black Box has gone out**.

12. USING THE (SUPER) BLACK BOX

12.2. Super Black Box option

Operation

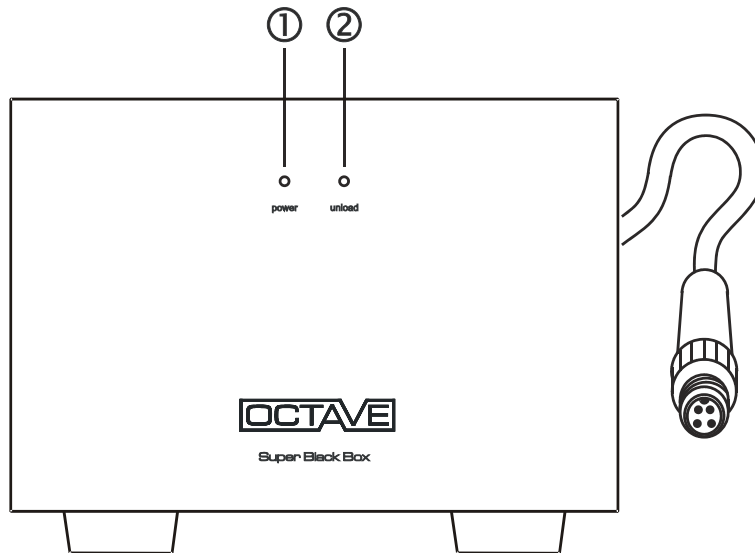

- ① **Blue power LED**
The blue "power" LED illuminates when the power amplifier (or integrated amplifier) is switched on via the amplifier's power on/off switch.
- ② **Yellow unload LED**
The yellow "unload" LED (discharge control circuit) illuminates for approximately two seconds after switch-off, and also in case the electronic protection is activated and if the V 70 SE is powered down through Ecomode on. The Super Black Box is equipped with a rapid discharge circuit, which discharges the unit's electrolytics. The yellow LED indicates that that this procedure is taking place. The discharge circuit also activates if the SBB connecting cable is accidentally removed. This is to prevent the SBB maintaining its charge when it has not been properly disconnected.

Specifications

Dimensions	203 X 159 X 320 mm (W x H x D)
Weight	7.5 kg
Connection cable	Length: 80 cm. Longer lengths are available upon request.

Connecting to the amplifier (Please see Black Box option).

11. TROUBLESHOOTING

11.1. Faults caused by external issues

Buzzing and hum in the speakers

◆ **Possible cause: multiple grounds**

Hum in an audio system is often caused by several system components having their own separate grounds. It is particularly common in systems containing tuners, VCRs or satellite receivers, as these components are connected to an aerial. Because aerials and cables are always grounded, ground loops can form between the aerial connection and other grounded equipment. Other equipment that is normally grounded may include PCs with sound cards, and some CD/DVD players and DACs.

Although the V 70 SE is grounded, its signal ground is a "floating" ground, which means that the V 70 SE cannot itself create ground loops. Hum can only be caused when it is connected to other items of equipment.

To fix the problem

Before trying to fix the problem, find out which of your system components is responsible for generating the hum.

Procedure:

- Unplug all source equipment, including any equalizer if used, from the V 70 SE, leaving only the loudspeakers connected.
- Reconnect the components back to the V 70 SE one at a time. As soon as the hum reappears, you have two grounded components connected to the V 70 SE. You must now unplug your components in reverse order to find out which of them is grounded.

Usually, the hum will still appear even when the problem components are switched off. The ground causing the problem is always connected, since it is not broken when the power switch is operated.

Now that you know which components are grounded, you can discuss the problem with your dealer.

One option might be to use a signal-isolating filter on the aerials or cable networks. These devices do not normally have any adverse affect on the sound or picture quality of tuners or TVs. Other possible solutions could include using an isolating transformer or an isolating device offering complete galvanic isolation. Please seek the advice of a specialist.

Power strips with built-in filters, mains filters or replacement mains cables are not appropriate solutions.

Note

Switching power supplies are quite common nowadays. These are often fitted with a protective earth terminal (PE) and an RFI filter. When using such units, the protective earth terminal **must** be connected to the wall socket. **You must never remove this protective terminal, as doing so could cause high levels of radio frequency interference to enter your system, which could affect the operation of other digital equipment, including remote controls.**

11. TROUBLESHOOTING

◆ Possible cause: induction

Another possible cause of hum could be the stray field of a transformer generating interference in a device or cable. You can easily diagnose this problem by switching off the problem component.

To fix the problem

To reduce this kind of interference, move the transformer/component or the affected component/cable to a different location.

The transformer in the V 70 SE will not generate interference, as it is electromagnetically shielded and has a very low stray field.

◆ "Phase" does not cause noise and hum

The mains polarity of the components in your system has no affect on noise and hum. That is a common fallacy. Swapping positive and negative in your mains plug will not make any difference to an earth loop. If it does, there is a fault with that component and you should not be using it.

Switching interference

Older fridges and 12V halogen lamps can produce strong radio interference when they turn on and off. Depending on the wiring in your home, this can result in clicks and pops in your loudspeakers.

To fix the problem

Modern domestic mains systems with a separate protective earth (PE) will normally suppress this interference. If you experience this type of switching interference, you either have a poor protective earth connection in your home or else your house does not use a PE system. In the latter case, you may not be able to eliminate switching interference entirely. In any event, the use of mains filters (in front of the device responsible for the problem) is certainly recommended.

Channels are not balanced

Level differences can have a variety of causes, although tubes are unlikely to be one of these.

1. The acoustics of the listening room may be affecting what you hear.
2. One of the drivers in your loudspeakers may be faulty.
3. There may be a faulty cable in your system

To fix the problem

You can trace the cause of this kind of problem by swapping speakers, cables, etc.

11. TROUBLESHOOTING

11.2. Faults caused by tubes, faulty tubes

Like other OCTAVE products, the V 70 SE is equipped with a double safety system. This means that the amplifier will be protected from damage if a component (tube) should fail and trip the electronic protection. The protection system protects the amplifier and the tubes from overload. This technology has proven its worth in recent years. *It has enabled us to reduce our overall failure rate (except for output tubes, which we are unable to control 100 percent) to virtually zero. OCTAVE equipment will achieve a service life of 10 to 15 years without needing to be serviced. We feel that this is particularly important aspect of tube equipment design, as many preconceptions still exist about the technology's durability and long-term stability.*

There are a number of reasons why tubes might fail at some point in their lifetime. You can fault-find tubes by examining their behavior.

Mechanical fault that does not trip the V 70 SE's protection

◆ The tube's heater filament no longer glows

No matter whether it is a driver tube or an output tube, no tube can work without a properly functioning heater.

Output tube heater fault

When the heater system on an output tube fails, you will be unable to adjust the BIAS. The particular tube will refuse to move from the minus setting. A loose connection inside the tube could have caused the heater to fail. It may be possible to repair the connection by mechanical means. If the BIAS was previously badly misadjusted, the BIAS might "run away", tripping the electronic protection.

This is why you should never turn the BIAS screws to the extreme right and leave them there. If you have not been able to adjust the BIAS satisfactorily, turn the adjuster screw back to its extreme left position.

Driver tube heater fault

When a driver tube heater fault occurs, you will normally lose an entire channel (depending on which driver tube system is affected by the faulty heater). This can only be established by a visual examination. The heater filaments are often difficult to see inside the driver tubes, since they only protrude very slightly from the tube system. OCTAVE uses double triodes exclusively, i.e. there are always two identical tube systems within the glass envelope. Because each of these triode systems has its own heater, you should always be able to see two glowing filaments. If you can only see one, it means that the tube is faulty.

◆ A tube has developed an air leak

The glass envelope of all tubes normally contains a vacuum. In order to maintain the vacuum throughout the service life of the tube, there is a device inside the tube that absorbs the residual gas. It is called the getter pill. It normally takes the form of a small crucible near the top of the tube. It contains a substance known as the getter, which absorbs and permanently retains the residual gas. This device ensures that the tube maintains a high vacuum during its entire service life. Hairline cracks around the base and leaks around the socket pins can cause the tube to take in air. Because the getter is only able to absorb a finite amount of gas, it will soon stop working. The silver coating at the top of the tube will then begin to discolor. If a tube has an air leak, you will not be able to adjust its BIAS voltage. As soon as a certain amount of air leaks into the tube, it will stop working completely and the heater filament will burn through.

11. TROUBLESHOOTING

Tube faults that trip the protection system

The protection system continuously measures the current flowing into the four power tubes. Depending on the problem, this current may exceed a specified limit and cause the protection system to switch the power stage off. The red protection LED will light up to show that this has happened. Once the protection circuit has been tripped, you will no longer be able to measure the BIAS of the power tubes and your amplifier will not produce any output. Exceeding the specified current limit can have a variety of causes.

◆ Faulty output tube

Aging and mechanical stresses from rough handling during transport can create an unwanted connection inside the tube, which can lead to failure of the tube.

How can you recognize a faulty tube? If you do not know what fault caused your amplifier to cut out, it is a good idea to disconnect the speakers and switch the V 70 SE off and on again. Before switching it back on, turn the mode selector to the BIAS position. Now check the correct operation of the tubes via the BIAS display. If the tubes are good, the sequence of events will be as follows:

- Four LEDs illuminate until the soft-start phase is complete.
- After the soft-start phase, the power tubes will begin to heat up and will visibly glow as current flows into the tubes. After approximately one minute, the BIAS display should read "green".
- A fault in one of the power tubes would result in an uncontrolled rise in current, which would cause the top, red BIAS LED of the relevant tube to illuminate after a short time. A further rise in current to the tube would then cause the protection system to trip. Should this happen, switch the V 70 SE off and replace the problem tube.

◆ Faulty driver tube

In very rare cases, a problem with one of the driver tubes can cause the V 70 SE to switch off. You can use the BIAS display to troubleshoot problems in the driver stage. The procedure is the same as the one described earlier, although the display will behave differently after the amplifier has warmed up. If one of these tubes is indeed responsible for the problem, both output tubes in the affected channel will behave erratically. This behavior may take the form of short, rapid changes in LED color - from yellow to green and red and back again. If the BIAS of both output tubes in one channel appears unstable, one of the driver tubes is generally responsible.

◆ Tube faults that degrade the sound

These faults are relatively uncommon and usually a result of a fault already described above. Thanks to the controlled soft-start circuitry, the tubes will retain their tone throughout their working life.

The V 70 SE's sophisticated, low-noise power supply circuits push hum and noise down to negligible levels. Tubes do not inherently produce hum or hiss: these problems are simply side effects of older, classic tube technology.

Noise, crackling or similar undesirable noises can be caused by residual gas or other residues in the tubes. This kind of noise does not often reach a level that could be considered annoying, although the nearer to the "front" the particular tube is, the more it will tend to make itself felt. In the V 70 SE, this would be tube V 5. As it is rare for both systems in a double triode to be equally affected, the noise levels in each stereo channel will be different. If you experience noise that is louder on one channel than on the other, the first thing to do is to change the V 5 tube (ECC 83 / 12AX7).

12. SPECIFICATIONS AND DIMENSIONS

In- and Outputs:

Inputs:	5 x RCA, 1 x XLR 1 x RCA Home Theatre Bypass input
Outputs:	1 x RCA Record Output, 1 x Regulated Preamplifier Output, 1 x Loudspeaker Output

Power amplifier

Output Configuration: Push Pull, advanced Pentode Mode, Grid 2 Voltage 300 V, Idle Current Tubes 28 mA - BIAS Low, 34 mA - BIAS High. Negative Grid Voltage separately adjustable for each Tube. Range: -16 to -40 V, 3 turn precision regulators.

Wideband Output Transformers using Silicon steel PMZ Core, single Impedance Output.

Optimum Load Impedance 3 - 16 ohms Nominal Speaker Impedance. Efficiency greater than 83 dB. Amplifier remains stable with No Load and Output short-circuited.

Output	2 x 70 W @ 4 ohms
Frequency response	20 Hz - 70 kHz @ 40 W -1 / - 3 dB 5 Hz - 70 kHz @ 10 W - 0 / - 2 dB
THD	0.1% at 10W @ 4 ohms
Signal-to-noise ratio	-100 dB / 40 W
Output Noise	less than 300µV
Optimal load impedance	3 - 16 ohms
Minimum load impedance	2 ohms
Gain	38 dB
NFB	10 dB
Tube set	4 x 6550 C
Quiescent current; output tubes	28 mA - BIAS Low, 34 mA - BIAS High

Preamplifier

Input sensitivity	180 mV Line Level Inputs
Input Impedance	50 k ohms
Crosstalk input to input	- 105 dB
Output Impedance Pre Out	240 ohms
Channel Balance	0.5 dB to - 70 dB on volume control
Channel Separation	55 dB
Max. Level Pre Out	5 V RMS
Tube set	1 x ECC 83, 2 x ECC 81

General

Soft Start, Inrush Current Limitation, Inrush Current on mains limited to approximately 350 W. Turn on Delay to Operation: 50 seconds.

Power consumption	< 20 W in Ecomode, 140 W idle, 400 W at full power
Weight	22 kg
Mains	100 V / 120 / 240 VAC available
Dimensions	451 x 150 x 415 mm (W x H x D)

12. SPECIFICATIONS AND DIMENSIONS

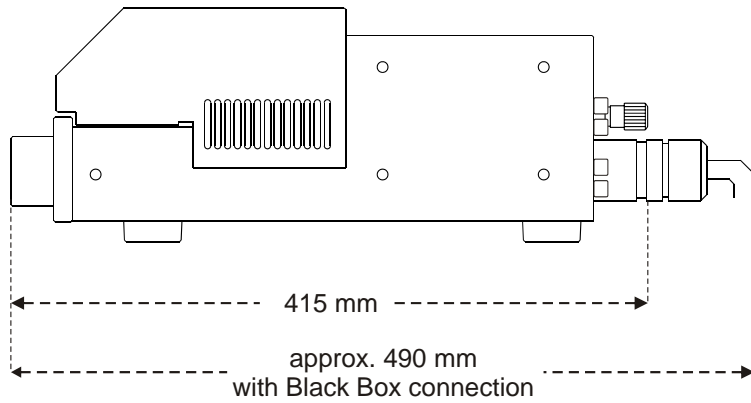
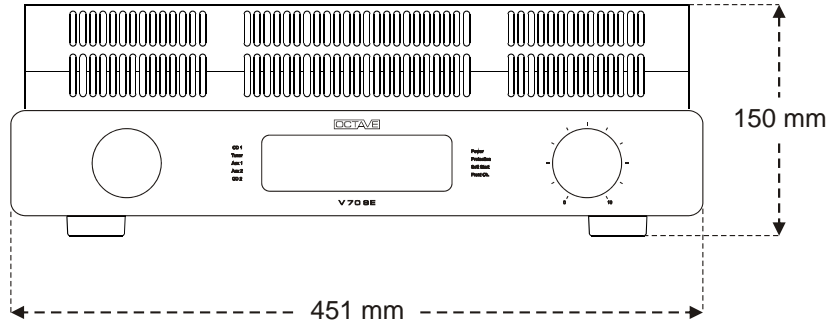

Diagrams

THD at 4V into 4 ohms from 30 Hz to 20 kHz at a variety of BIAS settings

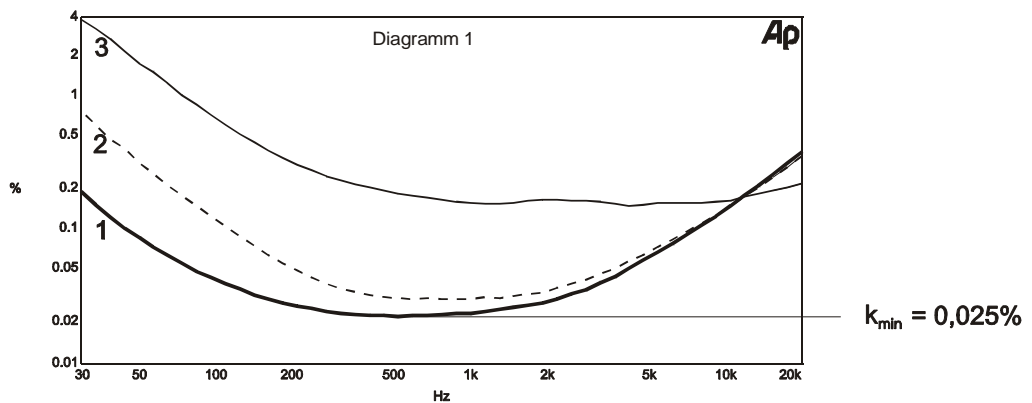

- Curve 1: BIAS adjusted correctly
- Curve 2: BIAS 10% out
- Curve 3: BIAS 30% out

12. SPECIFICATIONS AND DIMENSIONS

Graph 2: Frequency response, 5 W into 4 ohms

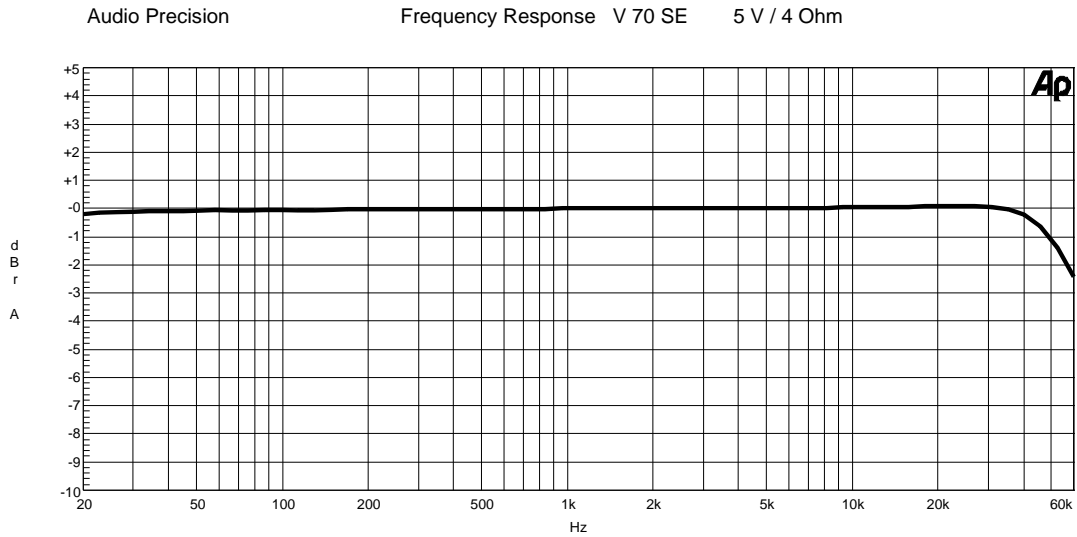

The frequency response curve clearly shows the low frequency extension of the V 70 SE linear to 10 Hz The loss at 20 Hz is less than 0,2 dB

Graph 3: Noise spectrum

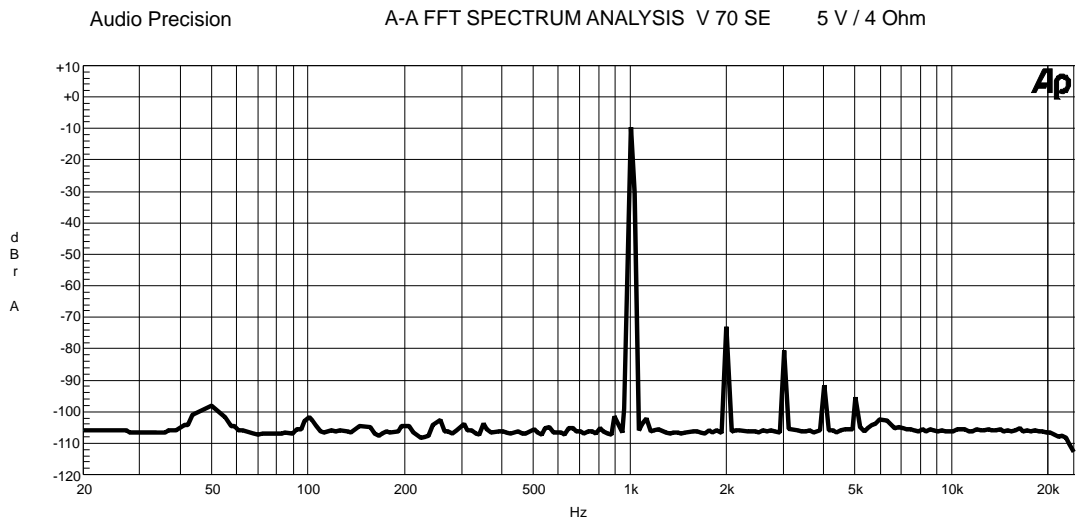

Noise spectrum at 1 kHz / 5 W into 4 ohm – there is no mains interference to be seen. (50 Hz < 200 μ V, 100 Hz < 70 μ V) The k2, k3, k4 and k5 noise spectrum is extremely low and falls quickly.

13. FAQ

1. Can you operate the V 70 SE when no loudspeakers are connected?

Yes. The V70SE, like all OCTAVE amplifiers, is fully protected against open circuit operation, i.e. the amplifier will come to no harm if it is operated without loudspeakers connected.

2. How do you recognize a faulty tube?

There are 3 different symptoms indicating a faulty tube:

1. A broken heater filament: the tube stops glowing.
2. A defective cathode layer: the tube glows, but no current can flow. You can confirm this fault using the bias display LEDs – no matter how much you try to adjust the bias, the minus LED will always remain on.
3. A short circuit inside the tube. Normally, this will cause the electronic protection to cut in and the red "off" LED to illuminate, or else the tube will refuse to respond to bias adjustment (the display keeps returning to the red area).

The amplifier will still operate with either of these faults present, but the channel containing the faulty tube will be quieter than normal. The fault may not be obvious at low listening levels but distortion will become evident at higher listening levels.

If fault 3 occurs, the protection circuits will normally switch the amplifier off. You may also hear loud background noises just before it switches off, although these will not harm the amplifier. (see chapter 6.1).

3. Is there a loss of sound quality as tubes age?

No. Tubes normally sound the same throughout their service life. Our soft-start technology contributes greatly to extending the service life of tubes. You can tell when an output tube has reached the end of its useful life: it becomes impossible to adjust it correctly. Driver tubes cannot be checked, but these will generally last for well over 10 years.

4. Does the V 70 SE have to have all of its tubes fitted?

In principle, the V 70 SE will also operate without tubes. It is sometimes useful to do this when testing the operation of the switching functions such as the selector switch, remote control, etc. Of course, it is not possible to play music under these circumstances.

For test purposes or as a temporary measure one channel may be fitted with just a single power tube, although its power output will, of course, be reduced. The amplifier will come to no harm if it is operated continuously like this.

Operation without driver tubes is also possible for test purposes, although, for obvious reasons, music playback is not possible.

5. What is the significance of loudspeaker impedance and efficiency?

The impedance and efficiency of modern loudspeakers is not an issue for OCTAVE amplifiers. The often-quoted damping factor is not normally a guarantee that an amplifier will exert tight control over the loudspeakers. In practice, speakers of 85 dB efficiency and above are suitable for use with tube amplifiers. The high stability of the OCTAVE power amplifier technology even allows the use of speakers whose impedance dips as low as 2 ohms.

6. What cables are suitable for tube power amplifiers?

The cable manufacturers are now offering cables that have supposedly been designed specifically for tube amplifiers. Although such cables may be of good quality, there is no need to use special cables with tube amplifiers. Speaker cable can exhibit high values of capacitance and inductance, and tube power amplifiers deal with such loads better than transistor power amplifiers. The only exception would be if you needed to use a tube pre-to-power amp interconnect cable longer than 5 metres. In that case, a low capacitance cable would be advisable.



We reserve the right to alter and improve the specifications in pursuit of better. OCTAVE logo is a registered trade mark of Andreas Hofmann. Copyright by Andreas Hofmann. Reproduction in whole or part is prohibited.
edited EN2010

OCTAVE AUDIO
Germany
www.octave.de