

Operating Manual

DVD

■ Viewvision DR+



LOEWE.

233-32818.022



Contents

Remote control Assist – recorder operation	3
Front Panel	4
Rear Panel & Display	5
Welcome	6
Scope of delivery	6
Set up	6
Shipping the Unit	7
Disposal	7
Advantages of connection to a Loewe TV set	7
About the internal hard disk	7
For your safety	8
Essential Information	9
Rewritable discs	9
Playable Discs	10
Notes on Discs	11
Disc-related Terms	11
Symbols	11
Initial Installation	12
Initial Remote Control Setup	12
Resetting the DVD Recorder	12
Switching over to Progressive Scan	12
Connections - General	12
Connecting to the Aerial	12
Connecting to the Television	13
Connecting to a set-top box / Satellite Receiver	13
Connecting to an External Decoder Box	14
Connecting to an Amplifier	14
Connecting Audio/Video (A/V) Accessories	15
Connecting a digital camcorder	15
Activating Digital Link	15
Basic Settings	15
Main menu	16
Setup menu	16
The General Menu	17
Language Menu	21
Audio Menu	22
Lock Menu	22
Recording Menu	25
Disc Menu	26
Additional Screen Menus	28
HDMI mode	29
Video mode	30
Playing back a DVD or video CD	30
Playing memory media with mixed contents	33
PIP (Picture In Picture)	33
DivX mode	34
Audio mode	35
Copy/move files/folders	36
Program list	37

Photo mode	38
Card-Reader mode	39
Remote control Assist – Card-Reader operation	40
Recording	41
Recordings on the HDD	41
Delayed TV viewing – Timeshift mode	41
Simultaneous record and display	42
Manual Record	42
Timer Recording	43
Timer recordings with the ShowView® system	43
Timer Record List	44
Record from external sources	44
Digital Video	44
Edit recordings	46
Menu Title List and Chapter List	46
Edit Original and Playlist	47
Add chapter markers	47
Create new Playlist	47
Add title/chapter to the Playlist	48
Delete title/chapter from Original/Playlist	49
Delete part	49
Title Name	50
Select title start point	50
Select chapter	50
Sorting	51
Undo/redo deletion	51
Combine titles	51
Divide title	52
Combine chapters	52
Move Playlists Chapters	53
Hide title/chapter	53
Protect title	53
Dubbing	54
Dub from HDD to DVD	55
Dub from DVD to HDD	55
Overwrite recordings	56
Title List menus on other devices	56
Playing on other devices	56
Troubleshooting	57
Technical Specifications	59
Masthead	59
Operating additional devices	60
Setting the remote control	60
Operating Loewe equipment	60
Remote control Assist – TV-operation	61
Language Code List	62
List of country codes	63
Glossary	64
Index	65
Service	66

Remote control Assist – recorder operation

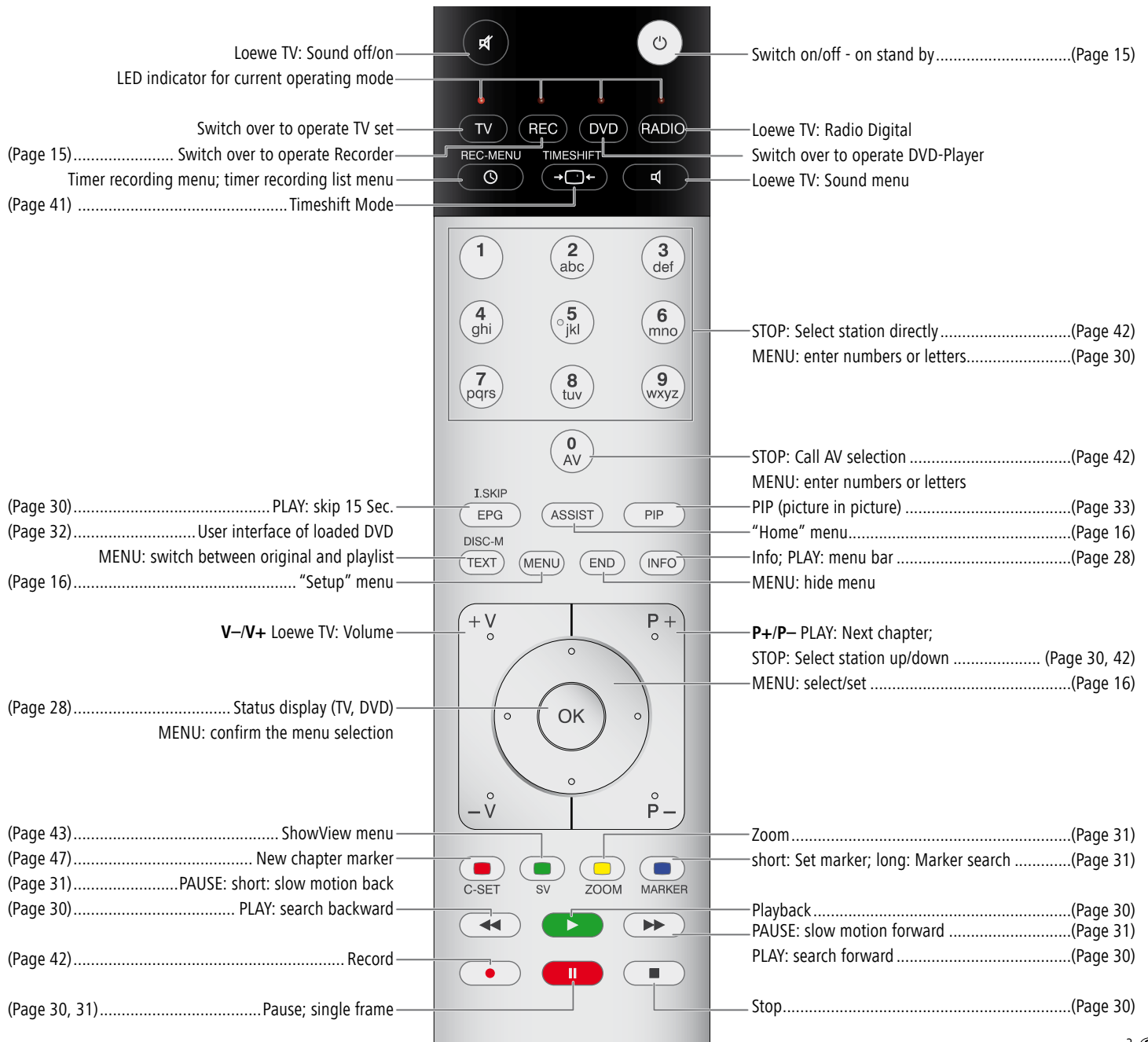

Front Panel

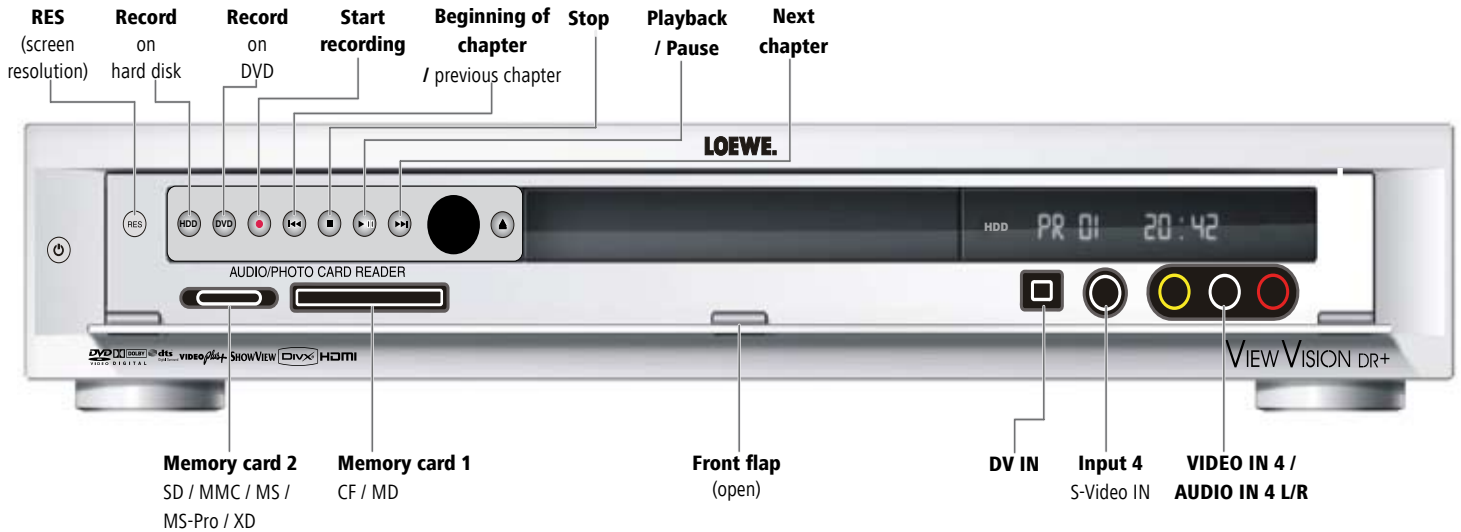
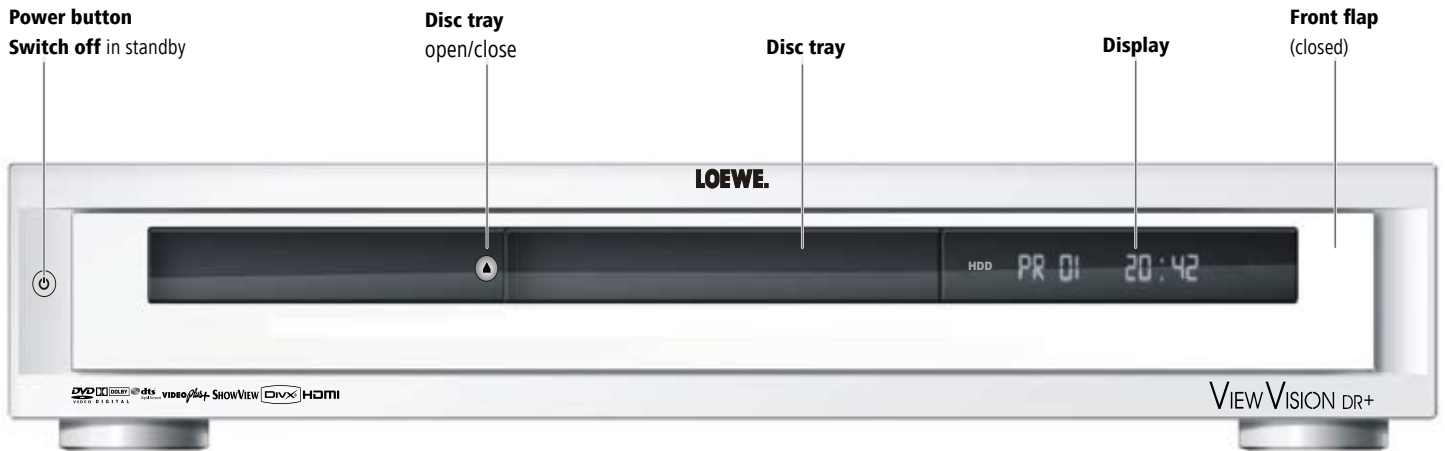

Rear Panel & Display

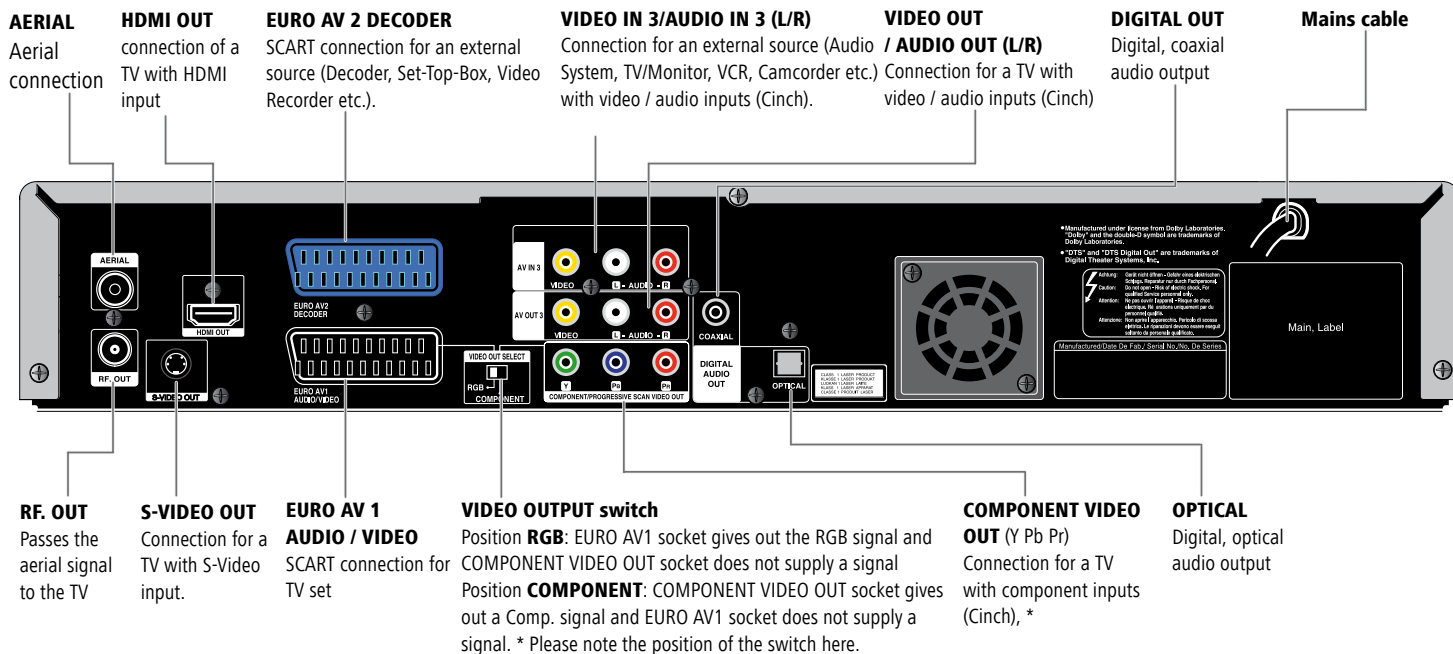

Caution: Do not touch the inner pins of connection sockets on the rear panel. Electrostatic discharge may cause permanent damage to the unit.

- T/S** Timeshift mode active
- REC** recording mode active
- HDD** hard disk in operation
- DVD** DVD in operation
- HDD ◀▶ DVD** dubbing mode active
- TV** TV reception active
- 🕒 Timer recording active or programmed

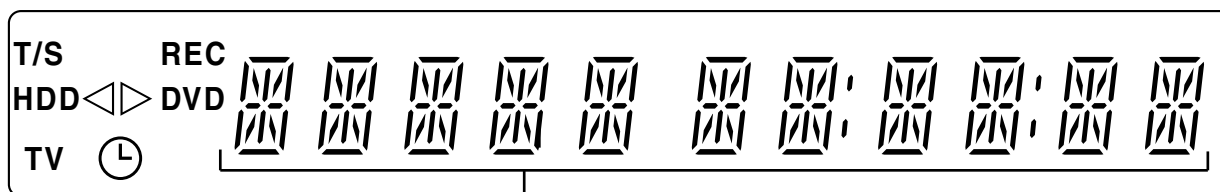

Character specifications
time, total playing time, time elapsed, title, chapter / track number, station, status etc.

Welcome

Thank you

for choosing a Loewe product. We are happy to welcome you as our customer. At Loewe we combine the highest standards of technology, design and user friendliness. This is equally true of TV, DVD, video, audio and accessories. Neither technology nor design is an end in itself, but both are intended to provide our customers with the best possible audio and visual experience. Our design is not influenced by short-term, fashionable trends. You have, after all, purchased a high-quality piece of equipment which you do not want to get tired of looking at tomorrow or the day after.

Scope of delivery

- recorder Loewe ViewVision DR+
- Assist remote control with 2 batteries
- Euro AV cable (Scart cable)
- Digital audio coaxial cable
- Audio cinch cable
- Video cinch cable
- Antenna cable
- HDMI cable
- 1x DVD-RW disc
- this operating manual

You can control three units with the remote control, apart from this recorder also a Loewe TV set and a Loewe DVD player or a Loewe Audio System.

Trademark rights

Manufactured under license from Dolby Laboratories. Dolby, ProLogic and the double-D symbol are trademarks of Dolby Laboratories. "DTS" and "DTS Digital Out" are trademarks of Digital Theater Systems, Inc. ShowView is a registered trademark of Gemstar Development Corporation. The ShowView System is manufactured under license from Gemstar Development Corporation. HDMI, the HDMI Logo and High-Definition Multimedia Interface are trademarks or registered trademarks of HDMI licensing LLC.

Set up

- Place the recorder on a firm, level base.
- Do not move the recorder during operation or just after switching it off.
- Do not place the recorder in the vicinity of sources of intense heat or in direct sunlight.
- When installing in a cabinet or enclosed shelf: Leave at least 2.5 cm free around the recorder to allow unhindered circulation of air and avoid build-up of heat. Do not cover up fan and openings on the rear.
- There can be interference to the images and sound of any nearby television, video recorder or radio. If this is the case, do not position the unit in the direct vicinity of a TV set, video recorder or radio, or switch the unit off after removing the disc.
- Position the recorder so that the infrared signal of the remote control can reach the display of the recorder unobstructed (or if this is not possible, see "Advantages of connection to a Loewe TV set", page 7).
- Do not place strong artificial light sources in front of the device. This may affect infrared reception.
- Incorrect voltages can damage the device. This device may only be connected to a power supply with the voltage and frequency specified on the rating plate, using the power cable provided.
- If there is an electrical storm, disconnect the antenna and mains plug. Power surges caused by lightning strikes can damage the unit through the antenna system or the mains.
- The antenna and mains should also be disconnected if the unit is to remain unsupervised for a long period of time.
- The mains plug must be easily accessible so that the unit can be disconnected at any time.
- Lay the cable in such a way that it cannot get damaged. The power cable should not be kinked or laid over sharp edges, not stood upon or exposed to chemicals - the latter also applies to the device as a whole. A mains cable with damaged insulation can cause electric shocks and is a fire hazard.
- Do not tug the cable when you remove the mains plug but hold the plug by the housing. The wires in the mains plug may be damaged and cause a short-circuit when you plug it back in.

You should also read and follow the safety advice on the following pages.

Welcome

Shipping the Unit

The original shipping box and packaging materials should be used to ship the unit. To give the unit the best possible protection, repack it as it was originally packed by the manufacturer.

Disposal

Cardboard box and packaging

In line with national regulations regarding the disposal of packaging materials, we pay a fee to authorised recyclers who collect packaging from dealers. However, we recommend that you keep the original cardboard box and the rest of the packaging materials so that the unit can, if necessary, be transported in the safest possible conditions.

The unit



Important: The EU Directive 2002/96/EG governs the proper re-acceptance, handling and recycling of used electronic appliances. Old electronic appliances must therefore be disposed of separately. Never throw this set in the normal domestic waste. You can hand in your old set free of charge at identified collection points or at your dealer if you buy a similar new set. Other details about re-acceptance (also for non-EU countries) are available from your local administration.

Remote control batteries

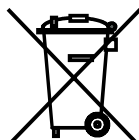

The batteries provided contain no harmful materials such as cadmium, lead or mercury. Regulations concerning used batteries mean that batteries may no longer be thrown out with the household rubbish. You can dispose of used batteries free of charge at the collection points in commercial outlets. Your dealer will also have a collection point for used batteries.

Advantages of connection to a Loewe TV set

With **Digital Link** you can install the recorder for example in a closed rack or a cupboard without direct visual contact with the recorder. With the DVD remote control, you operate the recorder via the Loewe TV set. **Digital Link** must be switched on on the recorder (page 15).

If you use the HDMI connection, the TV set is automatically switched over to this input if your TV set supports this function.

If you want to make timer recordings from the TV satellite tuner, **Digital Link Plus** controls the recording. With **Digital Link Plus** the station data of the aerial and cable stations of the TV set are transferred to the recorder so that the same stations are saved in the same order in both devices. This enables timer recordings of aerial and cable stations to be made comfortably on the TV set with the EPG (Electronic Program Guide). The timer data are transferred to the recorder which then makes the timer recording independently of the TV set. For timer data for satellite stations, the TV set starts and stops the recorder and sets it to the Euro AV 1 input. When play is started, this is shown immediately on the TV set regardless of which TV station you are currently watching (if the TV is switched off, it will be switched back on automatically first).

About the internal hard disk

The internal hard disk (HDD) is very sensitive. Operate the recorder according to the following regulations to avoid HDD errors.

Important recordings should be saved on DVDs to avoid losing data (page 54).

Do not move the recorder immediately after switching it off. To move the recorder, proceed as follows:

1. Wait at least two minutes after the message POWER OFF.
2. Pull out the mains plug.
3. Move the recorder.

Data on the HDD may be lost if the power fails during recorder operation.

The HDD is very sensitive. Improper handling or an unsuitable environment could damage the HDD after a few years in operation.

Sudden stopping during playing and visible mosaic effects in the picture are an indication of this. There may be no advance warning signs for an HDD defect.

Recordings cannot be played if the HDD is defective. The HDD must be replaced in this case.

For your safety

For your own safety and to avoid unnecessary damage to your unit, please read and follow the safety advice below:

Use for the intended purpose and ambient conditions

This recorder is intended exclusively for the reception, recording and playing of video and audio signals and is designed for the home and office and may not be operated in rooms with a high **humidity** (e.g. bathroom, sauna) or high **concentration of dust** (e.g. workshops).

The terms of the warranty only cover normal use of the recorder.

If the device is used outdoors, make sure that it is protected against **moisture** (rain, drips and splashes or dew). High humidity and dust concentrations lead to leak currents in the device which may lead to electric shocks or fires.

If you have moved the device out of the **cold** into a warm environment, leave it switched off for about an hour to avoid formation of **condensation**.

Always switch off your system (ViewVision DR+, TV set and any other audio components which may be connected) before connecting or disconnecting other devices or loudspeakers.

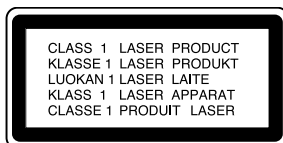

Do not open up the housing, or you could be directly exposed to the laser beam. The laser beam will be visible if the unit is open.

DO NOT LOOK INTO THE LASER BEAM.

Protect your recorder from:

- liquids and damp
- shock and mechanical stress
- magnetic and electrical fields
- cold, heat, direct sunlight and extreme fluctuations in temperature
- dust
- anything which obstructs ventilation
- manual interference with the unit's interior

PLEASE NOTE: TO AVOID RISK OF ELECTRICAL SHOCK, DO NOT REMOVE THE COVER (OR THE REAR OF THE UNIT). THERE ARE NO PARTS INSIDE THE UNIT THAT CAN BE REPAIRED BY THE USER. REPAIRS SHOULD ONLY BE CARRIED OUT BY A LOEWE DEALER.

Only use **original accessories** such as Loewe installation systems if possible.

Supervision

Do not allow **children** to use the recorder/TV set unsupervised. Do not allow children to play in the immediate vicinity of the recorder/TV set. They could knock, push or pull the equipment over and cause injury.

Cleaning

Only clean your recorder with a slightly damp, soft, clean cloth (without any aggressive cleaning agents).

If the recorder does not read a disc correctly, the reading unit in the device may be soiled. Use a commercially available cleaning disc.

Keep the disc drawer closed to prevent dust from the drawer getting onto the lens.

About this user guide

The information in this guide refers to the Loewe product Viewvision DR+ and Viewvision DR+ Secam - (version for France).

Unless stated otherwise, the instructions refer to the operating elements on the Assist remote control.

The explanations for DVDs in this guide refer to the DVDs recorded with this recorder. They do not apply for DVDs recorded on other recorders and played on this recorder.

Paragraphs beginning with the **►** symbol indicate important hints, tips or conditions for perfect operation.

Terms which you will find in the menu or printed on the recorder are printed in **bold** type.

In the functional descriptions, the necessary operating elements are arranged to the left of the text which contains the handling instructions.

Essential Information

Rewritable discs

DVD-RW (Digital Versatile Disc - ReWritable)



DVD-RW discs can be formatted for recording in the VR mode or in the video mode. These discs can be rewritten several times. Recordings can be deleted and the disc can then be rewritten.

VR mode Recordings can be extensively edited.

They can only be played on VR mode compatible players (after finalisation).

Video mode Limited editing possible.

Play on normal DVD players (after finalisation).

DVD-R (Digital Versatile Disc - Recordable)



These discs can be recorded once. A DVD-R disc cannot be rewritten or edited after finalisation. DVD-R discs can only be formatted for recording in video mode. Play on normal DVD players (after finalisation). Limited editing possible.

DVD+RW (Digital Versatile Disc + ReWritable)



DVD+ReWritable

These discs can be rewritten several times. Recordings can be deleted and the disc can then be rewritten. Play only on DVD+RW-compatible players (automatic finalisation). Edited contents can only be played after finalisation on DVD+RW-compatible players. Titles/chapters of recordings can be edited.

DVD+R (Digital Versatile Disc + Recordable)



DVD+R

These discs can be recorded once. A DVD+R disc cannot be rewritten or edited after finalisation. Play only on DVD+R-compatible players (after finalisation). Edited contents can only be played after finalisation on DVD+R-compatible players. Title/chapters can be edited conditionally.

➡ This recorder cannot write to CD-R or CD-RW discs.

➡ This recorder cannot write data discs (e.g. no MP3 or JPEG files).

➡ The displayed recording time is not exact because the recorder uses a variable bit rate video compression. This means that the exact recording time depends on the contents being recorded.

➡ When recording a television broadcast the remaining recording time may be shorter if the reception is poor or the picture contains interference.

➡ If you record only still pictures or audio, the recording time may be longer.

➡ The displayed recording time and remaining time may not always add up to the total length of the disc.

➡ The available recording time may be shorter following intensive editing of the disc.

➡ If you use a DVD-R disc you can continue recording until the disc is full or until you finalize it. Before you start recording check how much recording time is available on the disc.

➡ If you use a DVD-RW disc in video mode, the available recording time is extended again when you delete the last title recorded on the disc.

➡ The **Delete Parts** function (page 49) only hides the title but does not delete it from the disc and does not extend the recording time (except for the last recorded title on a DVD-RW disc in video mode).

➡ Overwrite recording is only possible on DVD+RW discs (Page 56).

Essential Information

Recording TV-Audio Channels

This recorder can also record NICAM audio. If the NICAM setting (page 20) is set to "Auto", NICAM audio will be recorded in the case of a NICAM transmission.

Restrictions on Video Recording

- You cannot record movie material with copy protection with this recorder. If a copy protection is encountered during recording, the recording stops or is interrupted automatically and a message is displayed on the screen.
- A video that can only be copied once can only be recorded using a DVD-RW disc in VR mode with CPRM (see below).
- NTSC format signals from analog or DV inputs cannot be recorded correctly with this recorder.
- SECAM format video signals (from an integrated TV tuner or from analog inputs) are recorded in PAL format.

CPRM

CPRM is a copy protection system (with scramble system) that only allows the recording of "copy once" broadcasts. CPRM is the abbreviation for "Content Protection for Recordable Media".

This recorder is CPRM compatible. You can therefore record copy-once broadcasts but cannot make copies of these recordings. CPRM recordings are only possible with VR mode formatted DVD-RW discs and can only be played on players with CPRM compatibility.

Copyright

- The recording equipment should only be used for lawful copying. You should find out what constitutes lawful copying in the country in which you are making a copy. Copying of copyrighted material e.g. films or music is only lawful if permitted by a legal exception or consented to by the rights owner.
- The product contains copyright protection technology through certain US patents and other intellectual property rights and is the property of the Macrovision Corporation and other companies. Use of this protection technology must be authorized by the Macrovision Corporation. It is only intended for private or other limited use unless otherwise authorized by the Macrovision Corporation. Reverse engineering and disassembly are prohibited.

Playable Discs



Video-DVD (8 cm- / 12 cm disc)



Video-CD (VCD, SVCD, 8 cm- / 12 cm disc)



Audio-CD
(8 cm- / 12 cm disc)



CD-R/RW

DVD-R/DVD-RW discs, DVD+R/DVD+RW discs, CDR/CD-RW discs with audio titles, DivX, *MP3/WMA or JPEG files, VCD/SVCD and Kodak Picture-CDs (JPEG) can also be played on this unit.

* including MP3 discs with ID3-Tag.

- ➡ DVD-R/RW, DVD+R/RW and CD-R/RW discs written to using a PC or a DVD or CD recorder cannot be played if the disc is damaged or dirty or if there is condensation on the recorder's lens.
- ➡ If you record a disc using a PC, even if it is in a compatible format, the disc may not play depending on the settings of the application software used to create the disc. (Further information can be obtained from the software provider).
- ➡ Depending on the recording unit or the CD-R/RW (or DVD±R/±RW) disc itself, some CD-R/RW (or DVD±R/±RW) discs cannot be played with this unit.
- ➡ Do not attach any labels to either side (the labeled side or the written side) of a disc.
- ➡ Do not use any irregularly shaped CDs (e.g. heart-shaped or octagonal). If you use these discs malfunctions may occur.
- ➡ Fingerprints and scratches on the disc can affect playback and/or recording. Take proper care of your discs.

Essential Information

Regional code of the Recorder and DVDs



This Recorder can only play Region "2" or "all" coded DVDs.

The region code on the label of some DVDs shows which type of DVD recorder can play those discs. If you play other discs the error message "Incorrect region code. Playback not possible." will be displayed on the TV screen.

Some discs may not have the label with the region code even though they cannot be played in all regions.

Notes on Discs

Handling Discs

Do not touch the prerecorded side of the disc. Hold the disc at the edges so as not to touch the surface with your fingers. Do not stick paper or tape to either side of the disc.

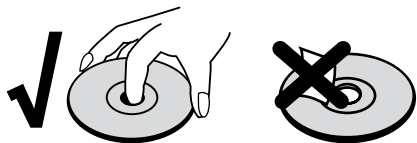

Storing Discs

After playing, store the disc in its case. Do not expose the disc to direct sunlight or a source of heat and never leave it in a parked car exposed to direct sunlight as there may be a considerable increase in temperature inside the car.

Cleaning Discs

Fingerprints and dust on the disc can affect the picture and sound quality. Clean the disc before playing it with a clean cloth. Wipe the disc from the center outwards.

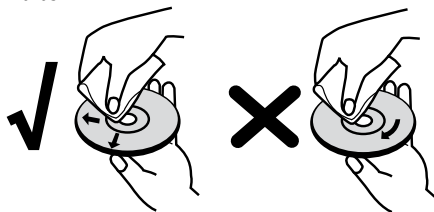

Do not use any strong solvents such as alcohol, benzene, thinner, commercially available cleaners or anti-static sprays intended for vinyl records.

Disc-related Terms

Title

A title is the main movie content or the music album. You have easy access by the title number.

Chapter (DVD)

Chapters are movie sequences or a piece of music which are parts of a title. You have easy access by the assigned chapter number.

Track (only Video-CD or Audio-CD)

Movie sequences or a piece of music on a Video-CD or an Audio-CD. You have easy access by the assigned track number.

Scene

On a Video-CD with PBC functions (Playback Control) the moving pictures and freeze frames are divided into sections called "scenes". You have easy access by the assigned scene number.

Symbols

The symbol on the screen

During operation,  may appear on the screen. This symbol means that the desired function is not available at the moment.

Disc symbols in the operating instructions

If part of the operating instructions contains one of the symbols listed below, the section is only applicable to the disc shown on the symbol.

Many functions of this recorder are dependent on the selected recording quality. One or more of the symbols (DVD, Video, +RW, MP3) are displayed for each function described in the manual so that you can immediately see whether the disc supports this function.

<i>HDD</i>	Title on HDD
<i>DVD ALL</i>	All DVDs listed below
<i>-RW Video</i>	DVD-RW Disc with video mode
<i>-RW VR</i>	DVD-RW Disc with VR mode
<i>-R</i>	DVD-R disc
<i>+R</i>	DVD+R disc
<i>+RW</i>	DVD+RW disc
<i>DVD-V</i>	DVD-Video disc
<i>VCD</i>	Video-CD
<i>CD</i>	Audio-CD
<i>DivX</i>	DivX/Xvid files
<i>MP3</i>	MP3 files
<i>WMA</i>	WMA files
<i>JPEG</i>	JPEG files

Initial Installation

Initial Remote Control Setup



To insert or change the batteries, press on the imprinted arrow. Slide off and remove the battery compartment cover. Insert alkaline-manganese LR 03 (AAA) type batteries and make sure the + and – poles are aligned correctly. Then, replace the cover.

Resetting the DVD Recorder

If any of the following problems occur.

- The unit is plugged in but will not turn on or off.
- The display panel does not work.
- The Recorder is not functioning normally.

the Recorder can be reset in the following way:

- ⏻ Hold down the button on the device for at least five seconds. The device switches off or pull out the power cable, wait at least 20 seconds and reconnect the cable.
- ⏻ Press the button again to switch the device back on.

Switching over to Progressive Scan

With the “Progressive Scan” mode you get the best possible picture quality without flicker the “Component Video” mode (**VIDEO OUTPUT** switch on the back of the recorder in position **COMPONENT** page 13) in display units which support this operating mode.

➡ Your recorder must be switched on.



Button **on the recorder**.

On: **576 P** appears briefly in the recorder display.

Off: **576 I** appears briefly in the recorder display.

Connections - General

➡ Depending on your television set and the other units you want to connect, there are several ways of connecting your recorder to your TV set. Only use the connection methods described below.

➡ Refer as necessary to the manuals for your television, recorder, stereo system and other units in order to make the best possible connections.

➡ The recorder must be connected directly to the TV set. Use the “connection wizard” for this in Loewe TV sets.

➡ Do not connect the Recorder **AUDIO OUT** socket to the audio system Phono In socket.

Connecting to the Aerial

Remove the existing aerial cable plug (**R**) for analog, terrestrial or cable TV from the TV and plug it into the aerial socket on the back of the recorder (**AERIAL** socket). Then plug one end of the aerial cable provided into the TV socket on the recorder (**RF-OUT**) and the other end into the aerial socket on the TV.

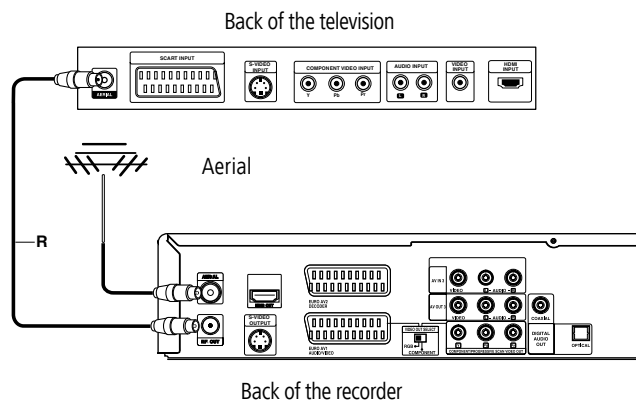

Initial Installation

Connecting to the Television

Make the following connections depending on the scope of functions of your existing equipment:

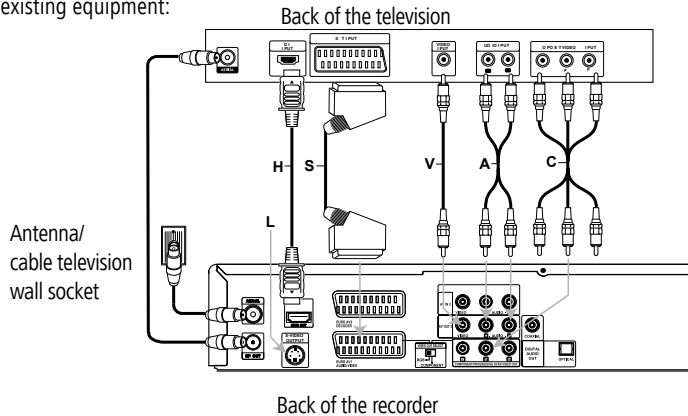

SCART connection

Connect the **EURO AV1 AUDIO/VIDEO** scart socket of the recorders to the appropriate input socket on the TV with the scart cable (S). Move the **VIDEO OUTPUT** switch to position **RGB**.

HDMI connection

Connect the **HDMI OUT** socket of the recorder to the HDMI input socket on the TV set with the HDMI cable (H) provided (HDMI socket 1 in Loewe). Make the settings as described on page 29. The SCART connection is required additionally for recording from the TV set.

Video connection

Connect the **VIDEO OUT** socket of the DVD player to the video input socket on the TV set with the video cable (V).

S-Video connection

Connect the **S-VIDEO OUT** socket of the recorder to the S-Video input socket of the TV set with the S-Video cable (L).

Component Video connection

Connect the **COMPONENT VIDEO OUT** sockets on the recorder to the appropriate input sockets on the TV set with a Y Pb Pr cable (available from your dealer) (C). Move the **VIDEO OUTPUT** switch to position **COMPONENT**.

Audio connection (left/right)

Connect the left and right **AUDIO OUT** socket of the recorder to the left and right **AUDIO IN** sockets on the TV set with the audio cables (A).

Digital Audio output

Connect the **DIGITAL-OUT** socket of the recorder to the **DIGITAL-IN** socket of the surround amplifier.

Connecting to a set-top box / Satellite Receiver

If you use a cable or satellite receiver with integrated decoder, connect it to your recorder and television set as described below. If you use a separate decoder box for your cable/satellite television, follow the instructions in the next section "Connecting to an External Decoder Box".

1. Connect the aerial cable as shown. This enables you to watch and record TV channels.
2. Connect the **EURO AV1 AUDIO/VIDEO** connection to a EURO AV socket on your TV set with the Scart cable. This enables you to view discs.
3. Connect the **EURO AV2 DECODER** connection to a EURO AV socket on your set-top box / your satellite receiver. This enables you to watch its TV channels.

► This recorder is equipped with a "Loop-Through" function. The function enables you to record a TV program from the integrated analog terrestrial TV tuner of this recorder while watching a satellite or set-top box channel. Do not connect the recorder "via" your video recorder, satellite receiver or set-top box.

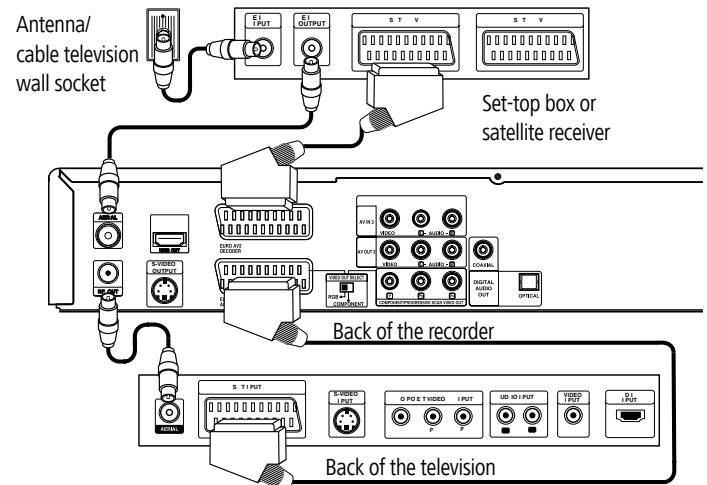

Initial Installation

Connecting to an External Decoder Box

If you use an external decoder box for your satellite or cable TV system, follow the connection procedure described below.

1. Connect your aerial socket in the wall to the aerial input socket on your set-top box / satellite receiver using an aerial cable.
2. Connect the decoder to the EURO AV DECODER socket on the set-top box /satellite receiver using a SCART cable. Further instructions can be found in the manual for your decoder box.
3. Connect the EURO AV2 socket on the DVD recorder to a **EURO AV 2** socket on your set-top box / satellite receiver using a SCART cable.
4. Connect the EURO AV1 socket on the DVD recorder to a **EURO AV 1** socket on your television using the SCART cable.

➡ Do not connect the Decoder-Box directly to the recorder but as shown in the figure below to the satellite/set-top box.

➡ Stations from the decoder (e.g. via Pay-TV services) can only be viewed when the recorder is switched off (standby mode).

➡ For timer recordings to work properly on this recorder, the satellite / set-top box must also be switched on during recording.

➡ With this configuration you cannot watch one television broadcast and record another at the same time.

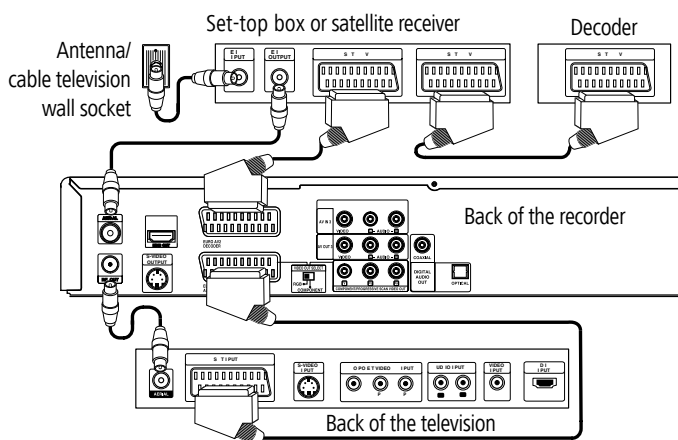

Connecting to an Amplifier

Connecting to an analog amplifier with analog 2-channel stereo or Dolby Pro Logic II / Pro Logic

Connect the left and right **AUDIO OUT** socket of the recorder to the left and right **AUDIO IN** sockets of the amplifier, receiver or stereo system with the audio cables (A).

Connecting to a digital amplifier with two-channel digital stereo (PCM) or to an audio/video receiver with a multi-channel decoder (Dolby Digital™, MPEG 2 or DTS)

1. Connect one of the **DIGITAL AUDIO OUT** sockets (**OPTICAL O** or **COAXIAL X**) of the recorder to the appropriate input socket on your amplifier. Use an appropriate digital audio cable (optical **O** or coaxial **X** - available from your dealer).
2. You must configure the digital output of the recorder (Page 22).

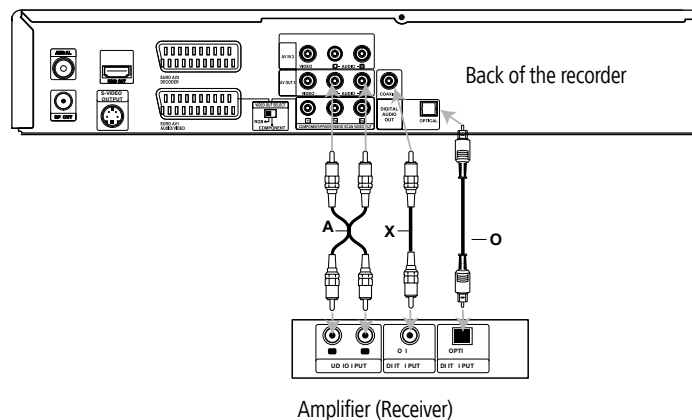

Digital multi-channel sound

A digital multi-channel connection offers the best sound quality. You will need a multi-channel audio/video receiver which supports one or more audio formats, e.g. MPEG 2, Dolby Digital and DTS. You will find information in the documentation enclosed with the receiver.

➡ Due to the DTS licensing agreement the digital output will be to DTS **DIGITAL-OUT** when a DTS audio stream is selected.

This recorder does not perform a (2-channel) decoding (downmix) of a DTS sound track internally. In order to enjoy DTS multi-channel surround sound, you have to connect this recorder to a DTS-compatible receiver via one of the recorder's digital audio outputs.

Initial Installation

► If the audio format of the digital output does not correspond to the capabilities of your receiver, the receiver will emit a strong distorted sound or no sound at all.

5.1 Digital surround sound via the digital connection can only be obtained if your receiver is equipped with a digital multi-channel decoder.

You can obtain information about the audio format of the current DVD via the "Disc Info" menu (Page 28).

Connecting Audio/Video (A/V) Accessories

Connect the input sockets (**AV2**, **AV3** = AUDIO IN 3 / VIDEO IN 3 on the back of the device or **AV4** = input 4 on the front of the device (page 4)) of the recorder to the audio/video out sockets of the accessory components with the audio/video cables.

► You can use either the **S-VIDEO IN** socket on the front panel or the **VIDEO IN** socket on the rear.

If you have connected a device to **AV2** and switched off its power supply, the Digital Link Plus function to the recorder is not possible.

Connector block for an accessory component (VCR, Camcorder, etc.)

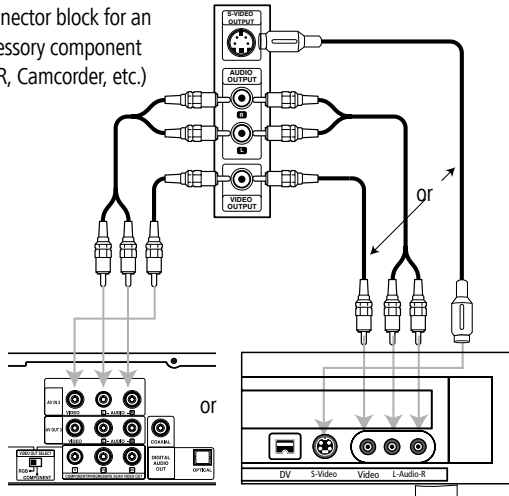

Back of the recorder

Front of the recorder

Connecting a digital camcorder

You can connect a digital camcorder (DV) or a digital DVD-R/RW recorder to the **DV IN** socket and transfer contents of DV tapes or DVDs digitally. Use a DV cable (not included in delivery) to connect the **DV IN-/OUT** socket of your DV-camcorder/video deck to the **DV IN** socket on the front control panel of this recorder.

► Only DV units can be connected to this socket (the source signal must be in the DV-25 format; see page 44). It is not compatible with digital satellite tuners or S-VHS video decks.

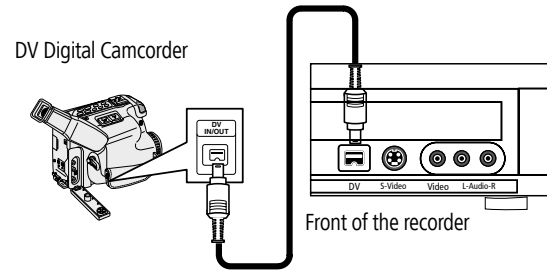

Activating Digital Link

With Digital Link, Loewe TV sets pass on the signals from the remote control through the Euro-AV connection on the recorder. Digital Link is useful when you want to put the recorder in a concealed place, e.g. in a closed rack.

► Your recorder must be switched on.



Button **on the recorder** for > 3 s

Digital Link on: **LINK** appears in the recorder display.

Digital Link off: **FRONT** appears in the recorder display.

Basic Settings



Set the remote control for recorder operation.



Push the On/Off button on the DVD recorder or



the On/Off switch on the remote control.

Initial Installation

Main menu

All media files can be called from the main menu for playing and recording with the recorder.

ASSIST

Call main menu.

◀ ▶ Select desired operating mode.

▲ ▼ Call options.

Confirm selection with **OK**.

ASSIST

Exit main menu.

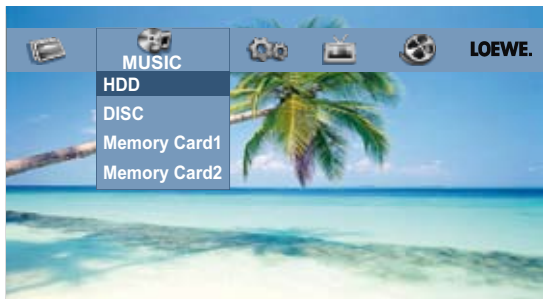

TV HDD: Live TV picture on – record on HDD.

DVD: Live TV picture on – record on DVD.

MOVIE HDD: Display the **Title List** menu of the HDD (page 46).

HDD DivX: Display the **Movie List** menu of the HDD (page 34).

Disc: a.) Display of **Title List** of a rewritable disc (page 46).

b.) Display of the **Movie List** menu of a DivX disc (page 34).

c.) Play a Video-CD or DVD-Video-Disc (page 30).

PHOTO (page 38)

HDD: Display the **Photo List** menu of the HDD.

Disc: Display the **Photo List** menu of the disc.

Memory card 1/2: Display the **Photo List** menu

MUSIC (page 35)

HDD: Display the **Music List** menu of the HDD.

Disc: Display the **Music List** menu (or Audio-CD) of a disc.

Memory card 1/2: Display the **Music List** menu.

Setup Call the **Setup** menu (this page).

Setup menu

The menu system offers several ways of changing settings. Most menus consist of three levels for setting up options. If you press **(MENU)** only the first and second levels of the menu system are displayed on the screen. You can display the third level by pressing ▶. When navigating in the menus, ▶ on the right side of the menu tab shows you that the next level can be called up.

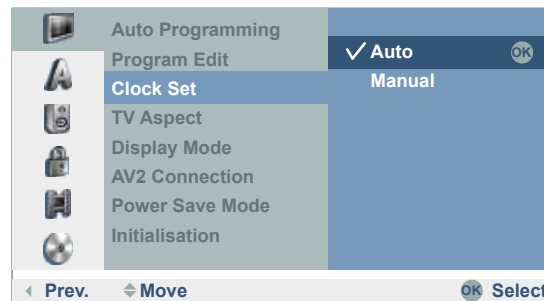

1. Level

2. Level

3. Level

Navigation in the menu

The arrow buttons of the Assist remote control are illustrated as follows in this user guide:



The arrows correspond in the text: “▲▼◀▶”.

The OK function is shown in the text as **OK**.



Call menu.

▲ ▼ Select desired option.

▶ Call second level.

▲ ▼ Select second option.

▶ Call third level.

▲ ▼ or ▶ to select the desired setting.

Confirm selection with **OK**.



Exit menu.

Initial Installation

The General Menu



Automatic programming

This recorder is equipped with an analog receiver (tuner) which can receive a maximum of 88 channels.

- When using Digital Link Plus, the channel setting is adapted to the TV set (on this page).
- Connect the recorder to the aerial system (page 12).



Call menu.

- ▲ ▼ Select **General** symbol.
- ▶ Call second level.
- ▲ ▼ Select **Auto Programming**.
- ▶ Mark country option.
- ▲ ▼ Select **Country**.
- ▶ Mark **Start**.



Start channel search.

The tuner runs through all the available channels automatically and transfers the found stations to the tuner memory.

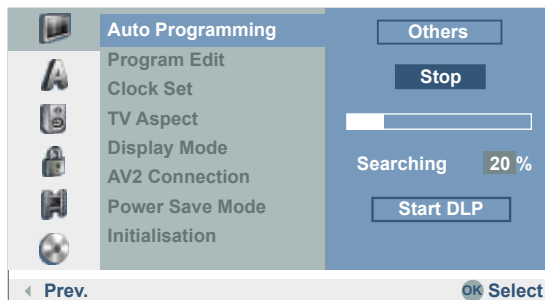

Digital Link Plus

If you have connected the recorder to a Loewe TV set with Digital Link Plus or a comparable system of another make (e.g. EasyLink, Mega Logic, Project 50), the station list will be transferred from the TV to the recorder. This happens when you log in the recorder to the TV set or when you change the stations on the TV set (resort, delete, add others). After such a change, the TV will prompt you to start transfer of the changed station list.

The recorder detects a connected TV set with Digital Link Plus or the comparable system of a different make and sets the recorder accordingly. Then you can no longer search for, delete or sort TV stations on the recorder. The menu items are displayed in grey, in the automatic search it is only possible to transfer the station data from the TV set.

Please note that all stations which you receive via aerial or cable have to be stored at channel slots 1 to 88 in the TV set. If the TV set does not prompt you to transfer the station data, start the transmission on the recorder.

Please make all station changes only on the TV set if your TV set is equipped with Digital Link Plus or a comparable system of another make.

If your TV set to which you have connected the recorder does not have Digital Link Plus or a comparable system, you should match up the stations lists of the recorder and the TV set. This makes it easier for you to find the channels on the TV set and the recorder.

- Connect the recorder to the TV set with Digital Link Plus with a SCART connection (page 13).
- If the recorder has taken over the stations from a Loewe TV via Digital Link Plus (DLP), the functions **Program Edit**, **Move** and **Delete** are locked and cannot be used again until the channels have been overwritten again by automatic programming.

Transfer station list



Call menu.

- ▲ ▼ Select **General** symbol.
- ▶ Call second level.
- ▲ ▼ Select **Auto Programming**.
- ▶ Press 3 times. The Start DLP button is marked.

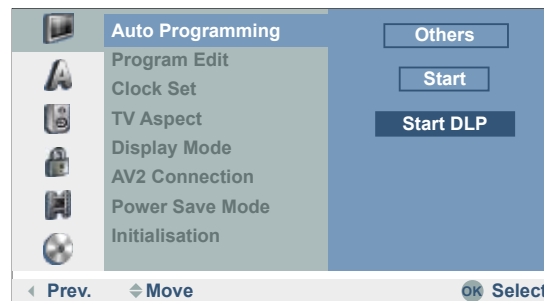

Start transfer of the station list from the TV to the recorder.

This may last a few seconds. The display on the recorder shows **DLP** during the transfer.

- (Viewvision DR+ Secam). French stations will only be transferred in the correct standard with Digital Link Plus if you select **France** as the country (see above) first.

Initial Installation

Program Edit

You can edit a channel manually (add, delete, rename, move etc.).



Call menu.

- ▲ ▼ Select **General** symbol.
- ▶ Call second level.
- ▲ ▼ Select **Program Edit**.
- ▶ Mark **Edit**.

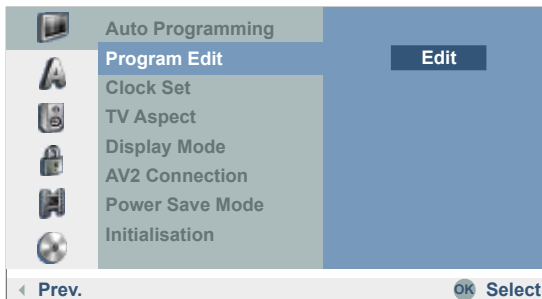

Confirm. The **Station List** menu is displayed.

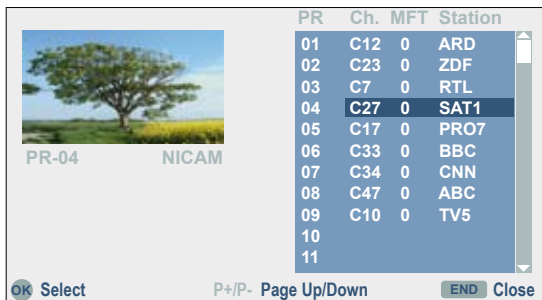

- ▲ ▼ Select **PR** number.

Confirm with **OK**.

The available options are displayed at the bottom left.

- ▲ ▼ Select option.

Confirm with **OK**.

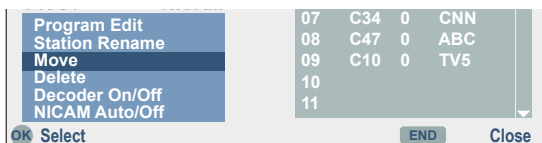

Explanations of the settings

- Program Edit** search, channel input, fine adjustment
- Station Rename** Change name
- Move** Move station in the station list
- Delete** Delete station from the station list.
- Decoder On/Off** Divert station via decoder (**on**).
- NICAM Auto/Off** Switch off NICAM reception (**off**).



Close menu.

Program Edit

In addition to the automatic programming, it is also possible to set and store stations manually.

▶ Not with Digital Link Plus (DLP).



- ▲ ▼ Select station in the **Station List** menu.

Confirm. The **Station List** menu is displayed.

The available options are displayed at the bottom left.

- ▲ ▼ Select **Program Edit**.

Confirm with **OK**.

The **Program Edit** menu is displayed.

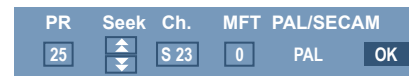

- ◀ ▶ Move the cursor to the previous / next column.

- ▲ ▼ Edit the setting at the current cursor position.

Explanations of the settings

- PR** Indicates the selected station number (display only).
- Seek** Searches for stations automatically.
 - ◀ ▶ Select **Seek** and then
 - ▲ ▼ start. The search is stopped when the recorder receives a station.
- Ch.** Changes the channel number.
 - ◀ ▶ Select **Channel** and then
 - ▲ ▼ set.
- MFT** Changes the frequency for manual fine tuning.
 - ◀ ▶ Select **MFT** and then
 - ▲ ▼ set.
- PAL/SECAM** Changes the reception standard in Viewvision DR+ Secam.
 - ◀ ▶ With distorted negative picture select **PAL/SECAM**
 - ▲ ▼ Select **SECAM** for the SECAM-L standard.

Confirm with **OK**.

Initial Installation

Station Rename

You can give whatever name you like to a station. Names should have a maximum of five characters.



▲ ▼ Select station in the **Station List** menu.

Confirm with **OK**.

The available options are displayed at the bottom left.

▲ ▼ Select **Station Rename**.

Confirm with **OK**. The **Keyboard** menu is displayed.

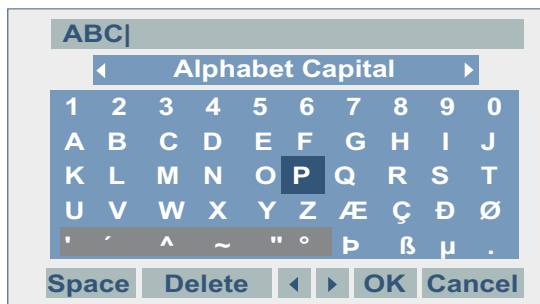

Enter a name for the station.

▲ ▼ ◀ ▶ Select character or function.

OK Insert character.

Explanations of the settings

Alphabet Capital Switches the keyboard to capitals.

Alphabet Small Switches the keyboard to small letters.

ABC...123 Inserts the selected character at the cursor position (shaded grey for special characters).

OK Save setting and exit.

Cancel Exit setting without saving.

Space Inserts a space at the cursor.

Delete Deletes characters to the left of the cursor.

◀ ▶ Moves the marker in the selection.

Inserts a space at the cursor.

Deletes the characters to the right of the cursor.

Deletes the character to the left of the cursor.

P+ / P- Moves the cursor to the left or right.

, Switches the keyboard back and forth between capitals and small letters.

Press the **OK** button at the end to confirm the settings and return to the **Station List** menu.

Moving stations

You can sort the order of stations in the **Station List** menu.

▣ Not with Digital Link Plus (DLP).



▲ ▼ Select station in the **Station List** menu.

Confirm with **OK**.

The available options are displayed at the bottom left.

▲ ▼ Select **Move**.

Confirm with **OK**.

▲ ▼ Select desired slot.

OK to go to the station list.

Delete Station

You can delete a station in the **Station List** menu.

▣ Not with Digital Link Plus (DLP).



▲ ▼ Select station in the **Station List** menu.

Confirm with **OK**.

The available options are displayed at the bottom left.

▲ ▼ Select **Delete**.

OK The station is deleted.

Decoder on/off



▲ ▼ Select the station which you want to divert via the decoder.

Confirm with **OK**.

The available options are displayed at the bottom left.

▲ ▼ Select **Decoder on/off**.

Confirm with **OK**.

When you select **On**, **Decoder** (with Secam: **Canal+**) appears underneath the station shown in the small picture.

Initial Installation

NICAM

This recorder can receive HiFi sound broadcasts in NICAM-Stereo. However, distortions may occur under unfavourable reception conditions. Switch off the function in this case (**off**).



▲ ▼ Select station in the **Station List** menu.

Confirm with **OK**.

The available options are displayed at the bottom left.

▲ ▼ Select **NICAM Auto/Off** under station list.

Confirm with **OK**.

When you select **Auto**, **NICAM** appears underneath the station shown in the small picture.

Clock set

When the automatic station search has finished, the date and time are set automatically (depending on the transmitting station), also when power is recovered. The **Auto** option must be set for this.

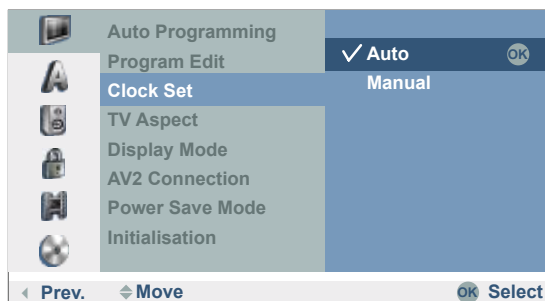

Call menu.

▲ ▼ Select **General** symbol.

▶ Call second level.

▲ ▼ Select **Clock set**.

▶ Call third level.

▲ ▼ Select **Auto**.

Confirm with **OK**.



Exit menu.

► Please check by pressing **INFO** in TV mode whether the year and date have been automatically set correctly. You may have to set it manually as described under "Manual setting of date / time".

Manual Setting of the Date / Time

It is possible that the television station may broadcast incorrect date and / or time information or no information at all and that the Recorder sets the incorrect time. If this is the case we recommend that you set the clock manually.



Call menu.

▲ ▼ Select **General** symbol.

▶ Call second level.

▲ ▼ Select **Clock set**.

▶ Call third level.

▲ ▼ Select **Manual**.

Confirm with **OK**.

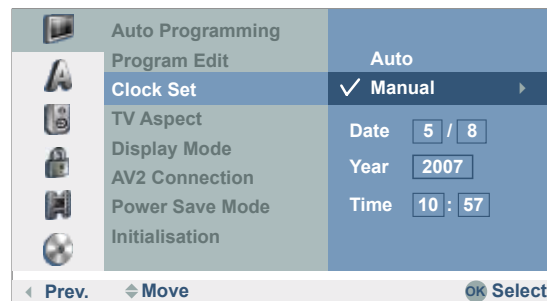

Enter the date and time.

◀ ▶ Move cursor.

▲ ▼ Enter data.

Confirm with **OK**.



Exit menu.

TV Aspect

You can choose:

4:3 Select this setting if a television set with 4:3 picture format is connected.

16:9 Select this setting if a widescreen television set with 16:9 picture format is connected.

Screen Mode

The screen mode setting is only available if the TV aspect of the television is set to 4:3. You can choose:

Letter Box Widescreen format recordings appear with black borders at the top and bottom of the screen.

Pan Scan The picture fills the whole screen but cuts off areas at either side that do not fit on the screen if required.

Initial Installation

AV2 connection

You can connect the following devices to the **EURO AV2 DECODER** connection on the back of the recorder:

Decoder Connect a Pay-TV or Canal+ decoder.

Others Connect a video recorder or similar device.

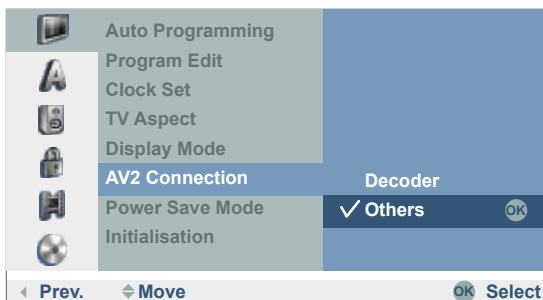

Energy saving mode

You can set the recorder so that it consumes < 1 Watt on standby. In the **On** setting, the VPS timer, the decoder signal transfer from AV2 to AV1 and "Digital Link Plus" are switched off (no recording via recording wizard of the TV set possible - page 44).

Initialisation

You can reset the recorder to its factory settings if necessary. Select Factory set and press **OK**.

➡ Some options cannot be reset with this (security stage, password, country code, station list, timer list).

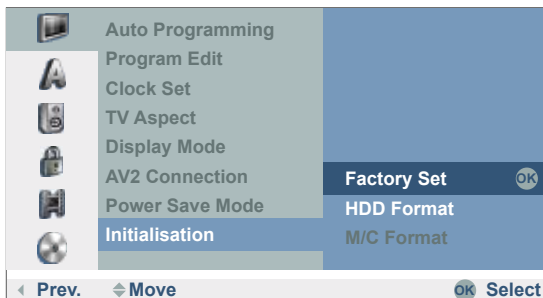

You can format the HDD and an inserted memory card by selecting the menu item **Format HDD** or **Format M/C**. Press **OK** and confirm the option **yes** with **OK**.

Language Menu

A

Menu Language

Select a language for the menus and dialogues displayed by the recorder.

(MENU)

Call menu.

▲ ▼ Select symbol **A** **Language**.

▶ Call second level.

▲ ▼ Select **Display Menu**.

▶ Call third level.

▲ ▼ Select **English**.

Confirm with **OK**.



Disc Languages

Select a language for the disc's menu, audio and subtitles.



If another language is to be used as the "original" version of the disc, select this here if it is available on the Disc.

Original The original language of the disc is selected.

Others Select other language with **Other** and confirm with **OK**. Enter the corresponding four-digit number from the "language code list" on page 62 and confirm with **OK**.

Initial Installation

Audio Menu



Each DVD disc offers a variety of audio formats. Set the audio format for the recorder according to the type of audio system you are using.

Dolby Digital / DTS / MPEG

PCM Select this option if the unit is connected to a digital two channel stereo amplifier. The DVD recorder's digital audio outputs emit sound in PCM 2 channel format if you play a DVD-Video disc with Dolby Digital audio format.

Bitstream Select "Bitstream" if you have a Dolby Digital decoder (or amplifier, a Loewe TV with AC3 or DIS module or another unit with Dolby Digital decoder) connected to the DIGITAL OUT socket of the DVD recorder.

OFF If you select "Off" the DTS signal is not emitted from the DIGITAL OUT socket.

Sampling Frequency

If your receiver or amplifier is NOT designed for 96 kHz signals, select 48 kHz. If you have made this selection, the unit automatically converts the 96 kHz signals to 48 kHz signals that the system can decode. If your receiver or amplifier is designed for 96 kHz signals, select 96 kHz.

Night Mode

Thanks to digital audio technology the DVD format enables you to hear soundtracks in the most accurate and realistic way possible. However, you may wish to limit the dynamics (i.e. the difference between the loudest and the quietest sounds). In this way you can play a film with minimum volume differences. For this purpose switch DRC to **ON**.

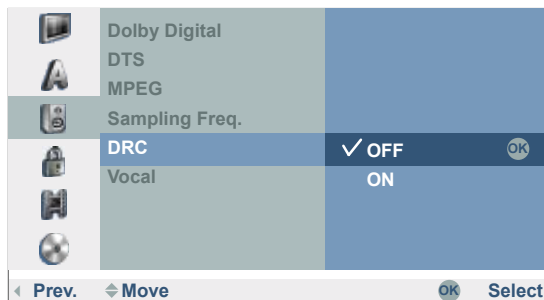

Karaoke Audio

Switch the singing option (**Vocal**) on, if you want to play a multi-channel karaoke DVD. The karaoke channels on the disc are mixed into normal stereo sound.

Lock Menu



Films on DVD can contain scenes that are not suitable for children. For this reason discs can contain child protection information that applies to the whole disc or only to certain scenes on the disc. The ratings are country-dependent. The child lock function enables you to prevent your children watching certain discs or scenes.

Set Password

Change the four-digit code.

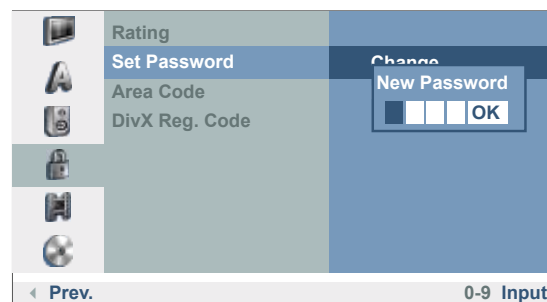

Call menu.

▲ ▼ Select symbol **Lock**.

▶ Call second level.

▲ ▼ Select **Set Password**.

▶ Call third level.

If you have not yet entered a password

Enter a four-digit number with **number buttons**.

Confirm with **OK**.

Enter password to check.

Confirm with **OK**.

If you have already entered a password

Select **Change**.

Confirm with **OK**.

Enter current password.

Confirm with **OK**.

Then enter a new four-digit password.

Confirm with **OK**.



Initial Installation

Enter password to check.

Confirm with **OK**.

► If you make a mistake, press ◀ repeatedly before you press **OK** to delete or correct the password numbers one after another.

Switching off the password

Proceed as follows if you want to switch off the password.



Call menu.



▲ ▼ Select symbol **Lock**.

▶ Call second level.

▲ ▼ Select **Set Password**.

▶ Call third level.

▲ ▼ Select **Delete**.

Confirm with **OK**.



Enter a four-digit number with **number buttons**.

Confirm with **OK**.

Delete Password

If you forget your password, proceed as follows to delete the current password.



Call menu.



Enter the six-digit number "210499" with the **number buttons**.

A message is displayed.



◀ ▶ Select the **yes** button.

Confirm with **OK**.

The four-digit password is deleted. Enter a new password as described above.

Rating

This function prevents playing of DVDs unsuitable for children if these contain the appropriate code.



Call menu.



▲ ▼ Select symbol **Lock**.

▶ Call second level.

▲ ▼ Select **Rating**.

	Rating	No Limit	OK
	Set Password	8 (Adult)	
	Area Code	7	
	DivX Reg. Code	6	
		5	
		4	
		3	
		2	
		1 (Children)	
◀ Prev.		Move ▶	OK Select

▶ Call third level.

Enter the four-digit password with the **number buttons** (see **Set Password**).



Confirm with **OK**.

▲ ▼ Select security stage between 1 and 8.

No Limit If you select "No Limit", the parental lock is not active. The disc will be played fully.

Step 1 to 8 Some discs contain scenes which are unsuitable for children. If you assign the recorder a security stage, only those scenes of the inserted disc will be played which correspond to the assigned security stage or have a security stage below it.

"1" has the most play restrictions.

"8" has the least play restrictions.

Scenes with a higher rating on the DVD are only played when appropriate substitute scenes are available on the disc. The alternative scene must have the same or a lower security stage. If no suitable alternative is found, the recorder stops playing. You have to enter the four-digit password or change the rating to play the disc.

Confirm with **OK**.

Initial Installation

Area Code

Enter the code for a country/region whose standards are to be used to rate the DVD-Video disc. (See "List of country code" on page 63). For Great Britain select "G B".

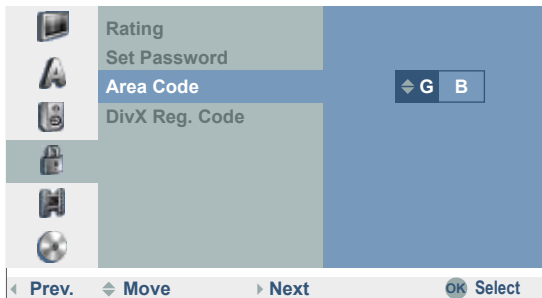

Call menu.



▲ ▼ Select symbol  **Lock**.

▶ Call second level.

▲ ▼ Select **Area Code**.

▶ Call third level.



Enter the four-digit password with the **number buttons** (see "Set Password").

Confirm with **OK**.

▲ ▼ Enter data.

◀ ▶ Move cursor.

Confirm with **OK**.

DivX registration code

You receive the DivX® VOD (Video On Demand) registration identification for hiring and purchasing films through the DivX® VOD-Service. Further information is available under:
www.divx.com/vod.



Call menu.



▲ ▼ Select symbol  **Lock**.

▶ Call second level.

▲ ▼ Select **DivX Reg. Code**.

▶ Call **View**.

Confirm with **OK**.

The "registration code" valid for your device is now displayed.

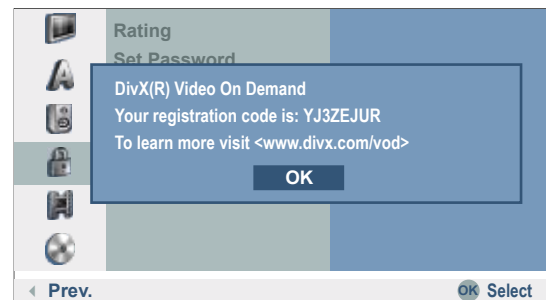

You can use this registration code to hire or buy movies through the DivX® VOD Service under www.divx.com/vod.

See the instructions for saving movies on a disc for playing on this recorder.

► All movies purchased from DivX® VOD can be played only on this recorder.

Initial Installation

Recording Menu



Rec Mode Set

You can set the picture quality for recording:

DVD+/-R/RW (4,7 GB)	HQ mode:	approx. 1 hour.
	SQ mode:	2 hours.
	LQ mode:	4 hours.
	EQ mode:	6 hours.

HDD (160 GB)	HQ mode:	approx. 43 hours.
	SQ mode:	approx. 80 hours.
	LQ mode:	approx. 152 hours.
	EQ mode:	approx. 227 hours.

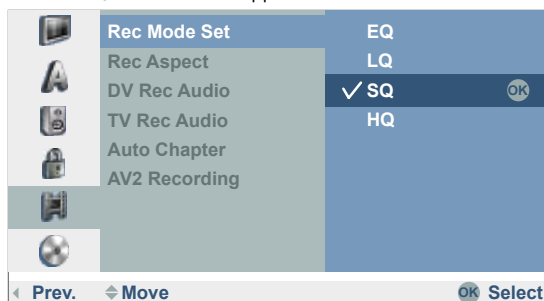

Call menu.



▲ ▼ Select symbol **Record**.

▶ Call second level.

▲ ▼ Select **Rec Mode Set**.

▶ Call third level.

▲ ▼ Set desired recording quality (EQ, LQ, SQ or HQ).

Confirm with **OK**.

Rec Aspect

You can adapt the picture format (16:9 or 4:3) to the material being recorded during the recording.

DV Rec Audio

You need to use this setting if your camcorder with 32 KHz / 12-bit is connected to the **DV IN** socket on the front panel. Some digital camcorders have two stereo tracks for audio. One is used for recording, the other is used for post-editing. On the **Audio 1** setting the original sound is recorded. On the **Audio 2** setting the edited sound is used.

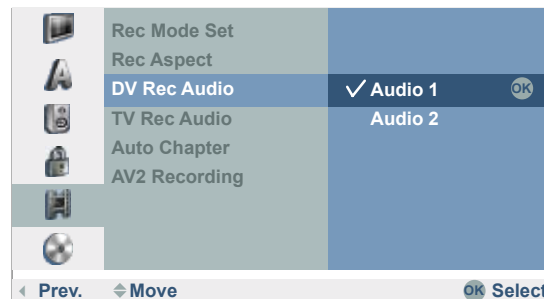

TV Rec Audio

When recording bilingual TV you can select the audio channel to be recorded.

Audio 1+2: both languages are recorded.

Audio 1: language 1 only.

Audio 2: language 2 only.

Auto Chapter

Chapter start marks are inserted at fixed intervals in recordings on DVDs in video mode. You can select intervals of 5, 10 or 15 minutes. If you select **None** automatic chapter setting is switched off.

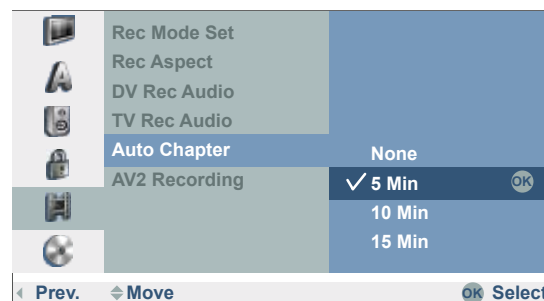

AV2 Recording

The signal type can be selected to record the video in signal of a device connected to the **EURO AV2 DECODER**.

Auto The video in signal is adapted automatically to the received video signal.

CVBS Only for recording a CVBS input signal.

RGB Only for recording an RGB input signal.

Initial Installation

Disc Menu



Disc Format

The recorder automatically initialises a new disc when it is inserted.

DVD-R The recorder initializes the disc in "video mode".

DVD-RW The recorder initializes the disc in "VR mode".

DVD+R The recorder initializes the disc in "video mode".

DVD+RW The recorder initializes the disc in "video mode".

► A DVD+RW or DVD-RW disc can also be initialised later by menu:

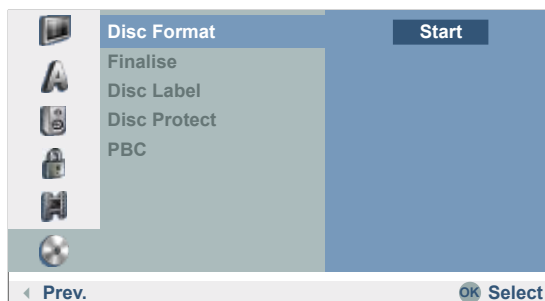

Call menu.



▲ ▼ Select symbol **Disc**.

▶ Call second level.

▲ ▼ Select **Disc Format**.

▶ Call third level.

OK call **Start** menu.

◀ ▶ Select a desired format for DVD-RW (**Video mode** or **VR mode**).

Confirm with **OK**.

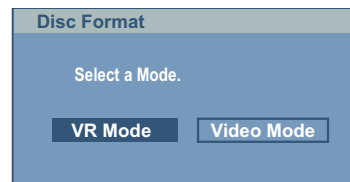

The following prompt appears:

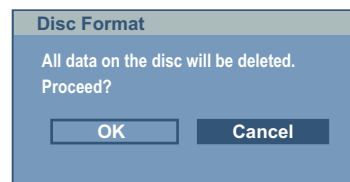

◀ ▶ Select **OK** button.

Confirm with **OK**.

► When you start formatting all recordings on the disc are deleted.

After pressing **OK** disc formatting begins. It can take a few minutes.

Finalisation

Finalisation fixes recordings so that the disc can be played on a regular DVD player or a computer with a suitable DVD-ROM drive. During finalisation of a Video mode disc a menu is created for disc navigation (Page 56).

► Following recording and finalisation of DVD-R and DVD+R discs no other editing or recording can take place. This does not however apply for a DVD+RW and DVD-RW disc.

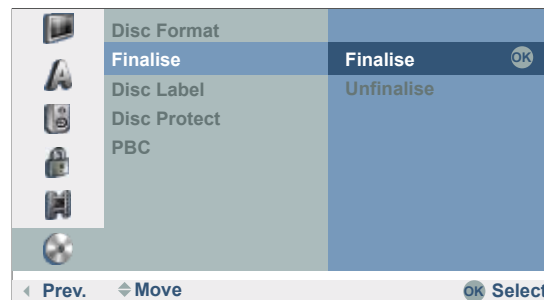

Initial Installation

MENU

Call menu.



▲ ▼ Select symbol **Disc**.

▶ Call second level.

▲ ▼ Select **Finalise**.

▶ Call third level.

▲ ▼ Select **Finalise**.

Confirm with **OK**.

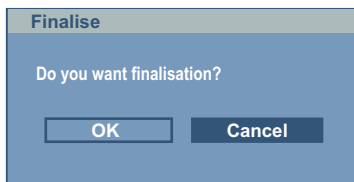

◀ ▶ Select **OK** button.

Confirm with **OK** to finalise the disc.

➡ The time needed for finalisation depends on the type of disc, how much is recorded on the disc and the number of titles on the disc. Finalisation of a prerecorded disc can take up to 8 minutes.

➡ When inserting a finalised DVD-RW, the finalisation can be cancelled by selecting **Unfinalise** in the **Finalise** menu. Then the disc can be edited and rewritten.

Disc Label

Use this option to enter a name for the disc. The name is displayed when the disc is loaded and when you display disc information on the screen.

➡ The disc name can be up to 32 characters long.

➡ For discs formatted on other recorders you will only see a limited character set.

MENU

Call menu.



▲ ▼ Select symbol **Disc**.

▶ Call second level.

▲ ▼ Select **Disc Label**.

▶ Call **Edit**.

Confirm with **OK**.

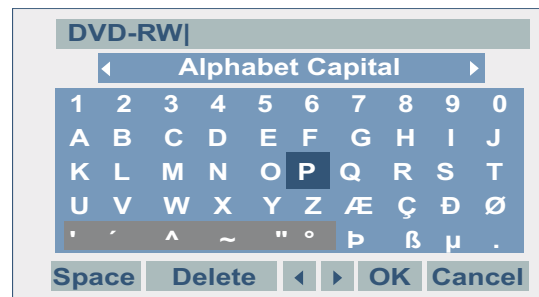

Enter a name for the disc.

▲ ▼ ◀ ▶ Select character or function.

Insert **OK** character.

See **Station Rename** on page 19 for functions.

Save with **OK** button.

Disc Protect

Set Disc Protect to **On** to avoid accidental recording, editing or deleting of the disc. To release the disc again, select **OFF**.

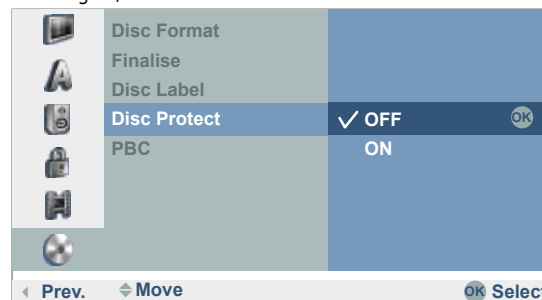

PBC - Play-Back Control

VCD, SVCD

If a VCD (or SVCD) possesses the property of Play-Back Control (**PBC**) and the PBC menu is set to **ON**, the disc is played via the menu on the disc. Otherwise the VCD can be played like an audio CD but without a track list.

Initial Installation

Additional Screen Menus

This manual contains basic instructions for operating the recorder. Some DVDs require specific handling or only permit limited operation during playback. If this is the case the  symbol appears on the screen. This indicates that certain operations are not permitted at certain points or that no menu is available on the disc.

The Disc Info menu

If you are currently watching a TV channel supplied by the integrated receiver of the recorder (recorder in Stop mode), you can show (and hide) information about the TV station and the inserted disc with **OK** or .

Example: A DVD-RW in the VR mode is inserted and the station **01** with the name "Kabel" is on at the moment:

Indicates the channel number, the station name and the audio signal (NICAM, STEREO, MONO, BILINGUAL) of the station you are currently watching.

Indicates in a progress bar the ratio of used to free space on the inserted disc, the free space in hours (H) and minutes (M) and the recording quality (for other discs see page 25).

Indicates the name, mode and format of the disc.

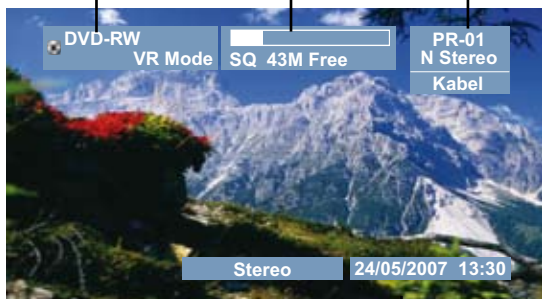

Indicates the current date and time.

Temporarily Visible Symbols



Resume play from this point.



Action prohibited or not available.

► Not all discs provide all the functions described below.

► The screen menu closes automatically when no buttons are pressed for 10 seconds.

Displaying Disc Information on the Screen during Disc Playback

You can display a variety of information about the inserted disc on the screen.



Twice to select the Title menu.

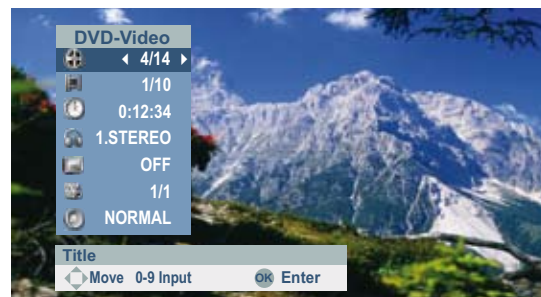

▲ ▼ Select the desired function.

- Title** Current title (or track number)/total number of titles (page 30).
- Chapter** Current chapter number/total number of chapters (page 30).
- Time** Elapsed playing time (page 31).
- Sound** Selected sound formats, movie language and audio channels (page 32).
- Subtitles** Selected subtitle (page 33).
- Camera** Selected camera position / total number of camera positions (page 32).
- Sound** (3D-surround) selected sound mode (page 32).



Exit menu.

HDMI mode

HDMI (DVI) connection

The HDMI connection (High Definition Multimedia Interface) allows digital picture and sound transmission via a connecting cable, e.g. to Loewe Flat TV sets. The digital picture and sound data are transmitted without data compression and therefore lose none of their quality. In the equipment connected, no analogue/digital conversion is necessary, which might also have led to losses in quality. DVI signals can also be reproduced by the HDMI connection using a DVI/HDMI adapter cable. This is possible because HDMI is based on DVI and is downwardly compatible. That means that the digital video signals are transmitted via HDMI - no audio signals are transmitted, though. In addition, both use the same copy protection method HDCP (High Definition Content Protection).



Switch off the TV set/monitor with HDMI connection and recorder.

Connect recorder to TV set/monitor via HDMI connection as described on page 13.



Switch on the TV set/monitor.



Switch on the recorder after 30 seconds.

Log in the HDMI connection in the connection wizard of the TV set (see user guide TV set).

► DVI: If a DVI-HDMI adapter cable is used for transmission, connect the analog or digital audio outputs on the recorder with the corresponding inputs of the TV set as described on pages 13 and 14.

Leave the existing SCART connection as it is to record from the TV.

HDMI operation



Switch the TV set over to the HDMI AV input (takes place automatically in connection with a -Loewe Flat-TV set, see page 13).



Press the **RES** button on the recorder repeatedly to set the desired picture resolution (e.g. **576i**, **576p**, **720p**, **1080i**).

► You can only set resolutions which your TV set/monitor is capable of. For optimum picture quality, select the resolution **1080i** on the recorder.



Open the disc drawer.

Insert the selected disc in the drawer with the side to be played facing down.



Close the drawer.



Call main menu.



◀ ▶ Select **FILM**.

▲ ▼ Select **HDD**, **HDD DivX** or **Disc**.

Confirm selection with **OK**.

A menu appears on the screen.

▲ ▼ ◀ ▶ Select title on DVD.



Depending on the medium, playing starts automatically or is started with the Play button or you have to make entries in the menu.

► The other sockets (VIDEO OUT, S-Video and Component Video) have no function during the HDMI mode.

► With an HDMI connection the audio scanning frequency is only 48 kHz, even when selecting 96 kHz.

► This recorder performs no internal (2-channel) decoding of DTS soundtracks. In order to enjoy DTS multi-channel surround sound, this recorder must be connected by one of the digital audio outputs to a DTS-compatible receiver.

► If the "Dolby Digital" or "MPEG" option has not been set to "PCM" in the Sound menu (page 22), no sound is output through the TV set.

► The HDMI connection to the recorder is operated as a signal output. Please proceed as described on page 44 if you want to record from an external signal source with the recorder.

Video mode

Playing back a DVD or video CD

Preparation

Switch the television on and set the video source to be the input that the recorder has been connected to or activate the "Control voltage" option for the television's AV input.

If you have connected the recorder to an audio system, switch on the audio system and, as the source, set the input that the DVD recorder has been connected to.



Open the disc drawer.

Insert the selected disc in the drawer with the side to be played facing down.



Close the drawer.

READING shows on the display while disc recognition is in progress.

Play



Call main menu.



◀ ▶ Select **FILM**.

▲ ▼ Select **HDD, HDD DivX** or **Disc**.

Confirm selection with **OK**.

A menu appears on the screen.

▲ ▼ ◀ ▶ Select title on DVD.



Start / continue playing.



Select title on (S)VCD.

The menu setting and the exact operating instructions for the disc may differ from disc to disc. Follow the instructions on the individual menu pages.



Pause: Pause playing.



Stop: Finish playing.

You will find further information on page 28.

➡ If the child lock is active and the DVD disc's security rating is higher than that of the child lock, the four-digit password will need to be entered (see "Ratings" on page 23).

➡ DVD's have a country code. The recorder will not play a disc that has a country code which differs from the country code stored in the unit. This player has country code 2.

➡ You can also switch off (**OFF**) PBC for (S)VCD (see page 27) in the main menu.

General functions

➡ Unless otherwise indicated, the remote control (page 3) is able to control the functions described. The recorder's own controls can also be used to control certain functions (page 4).

Select **TITLE** *HDD DVD-ALL DivX*



Twice to select the Title menu.



▲ ▼ Select  symbol.

◀ ▶ Select title number.

OK start playing.

Select **CHAPTER / TRACK**

HDD DVD-ALL VCD

If a title has several chapters/tracks, you can select another chapter/track as follows:



P+ or **P-** during playing to select the next chapter/next track or return to the beginning of the current chapter/track.

P- twice briefly to return to the previous chapter/track.

Search *HDD DVD-ALL VCD DivX CD*

Select the search direction and speed:



Press several times for faster search in reverse.



Press several times for faster search forwards.

Speed and direction are shown as arrows.



End search mode and continue playing.

Skip



◀ ▶ Jump back/forward 5 minutes during playing (*HDD*).

Jump forward 15 seconds during playing (*HDD, DVD±R, DVD±RW*).



Video mode

Freeze frame and picture for picture play-back

HDD DVD-ALL VCD DivX



Pause: Pause playing.



◀ ▶ Scroll picture by picture.



Continue playing.

⇒ The picture by picture scroll back is not supported by Video-CDs and in DivX. You can page forward through images by pressing **PAUSE** on the remote control.

Slow Motion

HDD DVD-ALL VCD



Pause: Pause playing.



Switch on slow motion mode during pause.

Select the slow motion direction and speed:



1/16, 1/8, 1/4, 1/2 (reverse).



1/16, 1/8, 1/4, 1/2 (forwards).



1/8, 1/4, 1/2 (forwards / VCD).

Slow motion speed and direction are displayed.



End slow motion mode and continue playing.

⇒ On Video-CD the slow motion play-back in reverse is not supported.

Repeat HDD DVD-ALL VCD CD MP3

DVD-Discs



Select type of repetition.

Chapter

Repeats the current chapter.

Title

Repeats the current title.

All

Repeats all titles on the disc (VR mode; only DVD-RW disc).

Off

No repeat.

Video-CDs / DivX



Select type of repetition.

Track

Repeats the current track.

All

Repeats all tracks on the disc or in the folder (DivX).

Off

No repeat.

⇒ On a Video-CD with PBC you have to set **PBC** to **OFF** in "Disc" menu of the main menu to use the repeat function. You will find further information on page 27.

Time (Play from ...) HDD DVD-ALL DivX

The "Time" function enables you to select where a disc starts playing.



Press twice.

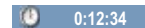

The elapsed playing time of the current disc is displayed in the "Time" box.



▲ ▼ Select  symbol.



Enter time in format h:mm:ss.

OK start playing from set time.

Zoom HDD DVD-ALL VCD

With the Zoom function you can enlarge the video picture during playback and navigate in the enlarged picture.



Select Zoom function during play/freeze frame.

Zoom stages: x1, x2, x4, x1 (normal size).

◀ ▶ ▲ ▼ Select picture section.



Close Zoom window.

⇒ The Zoom function may not work on certain DVDs.

Markers HDD DVD-ALL VCD

You can start playing from a saved marker. A maximum of six markers may be saved.



Set Marker

Press the blue button briefly to set a mark at a selected point.

The marker symbol is displayed on the screen for a short time.



Repeat this step to enter a maximum six markers on one disc.

Call Marker



Press the blue button long to select **Marker Search** menu.



▲ ▼ ◀ ▶ Select marked scene.

OK Start playing from marked scene.

Video mode

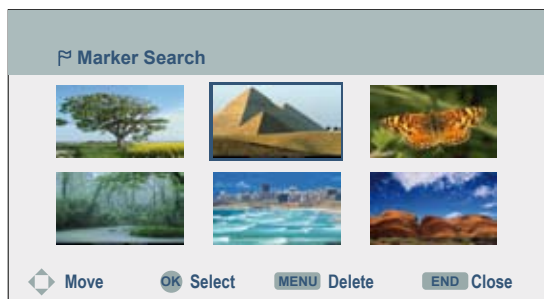

Delete Marker

Press the blue button long to select **Marker Search** menu.



▲ ▼ ◀ ▶ Select marked scene.

Delete Marker.

◀ ▶ Select **yes** option.

Confirm with **OK**.



Exit the Marker Search menu.

► The markers are only saved until the disc is changed (*DVD-ALL VCD*).

Disc menu *HDD DVD-V VCD*

DVDs and Video CDs usually contain their own menus.



Select **Disc menu**.



▲ ▼ ◀ ▶ Select the desired settings.

Confirm with **OK**.



Exit **Disc menu** *DVD*.



Exit **Disc menu** *HDD*.

Camera positions *DVD-V*

If the DVD contains scenes taken at different camera positions, it is possible to change to another camera position during play-back.



Select twice during play-back.

▲ ▼ Select symbol.



◀ ▶ Select the desired camera angle. The number of the current camera position is displayed.



► A camera symbol will appear on the screen during scenes that were recorded using different camera positions.

Digital sound formats, movie language and audio channels

You can select the digital sound format in connection with the movie language here.



Select twice during play-back.



▲ ▼ Select symbol.



◀ ▶ Select other movie language or sound format (*DVD-V DivX*).

◀ ▶ Select other audio channel (STEREO, LEFT or RIGHT) (*VCD Video VR*).

► Some discs have got Dolby Digital and DTS sound tracks. If DTS is selected, there is no analogue audio output. To listen to the DTS sound track, connect the recorder via one of the digital outputs to a DTS amplifier (page 14).

3D-Surround *DVD-ALL VCD DivX*

This device can create a 3D surround effect which simulates a multi-channel audio reproduction with two conventional stereo speakers.



Select twice during play-back.



▲ ▼ Select symbol.



◀ ▶ Select **3D SUR**. for surround sound.

◀ ▶ **NORMAL** to end surround sound.

Video mode

Subtitles *DVD-ALL DivX*

 Select twice during play-back.



▲ ▼ Select  symbol.

 OFF

◀ ▶ Select the desired subtitle language.

Playing memory media with mixed contents

If the memory media contain files of different playing formats such as MP3, JPG and DivX, you can switch between the three play modes **MOVIE**, **PHOTO** and **MUSIC** with the button  in the main menu (page 16):

- ➡ For operation of the **MOVIE** mode, see chapter “DivX mode” on page 34.
- ➡ For operation of the **MUSIC** mode, see chapter “Audio mode” on page 35.
- ➡ For operation of the **PHOTO** mode, see chapter “Photo mode” on page 38.

Storing the last disc settings

DVD-V Video VR

The recorder saves the user settings for the last disc that you have watched. The settings are saved until you remove the disc from the recorder or switch it off. If you insert a disc that has already been played back, playback will continue from the last stopping point.

PIP (Picture In Picture)

HDD DVD-ALL

This function enables you to watch TV stations or videos from other connected AV sources whilst playing the video.



Start play-back.



Switch on small picture.



Select station for small picture in TV mode.



Select signal source for the small picture in the order Tuner, AV1, AV2, AV3, AV4, Tuner.



End play-back and PIP. Transfer small picture to large picture.



◀ ▶ Select desired small picture position.



Yellow button – Select Zoom function for the small picture.

Three different sizes are available.



Switch off small picture.

DivX mode

With this recorder you can play DivX files which are saved on HDD, CD-R/RW or DVD±R/RW media.

► Before playing DivX files, please read the notes "About DivX Video files" on this page.

Playing DivX files



Open the disc drawer.

Insert the selected disc in the drawer with the side to be played facing down.



Close the drawer. The disc is read.



Call main menu.



◀ ▶ Select **MOVIE**.

▲ ▼ Call **HDD DivX** or **DISC**.

Confirm selection with **OK**. The **Movie List** menu appears on the screen.

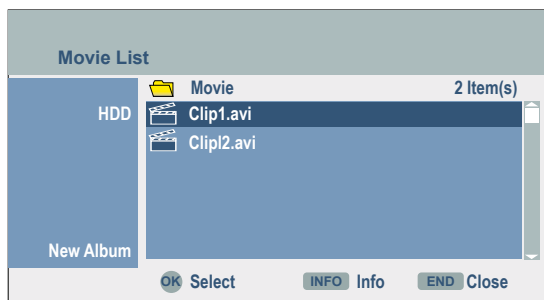

▲ ▼ Select title or folder.

OK show menu options for file.

▲ ▼ Select option.

Confirm with **OK**.



Start play-back.



P+ or **P-** during play-back to select the next title or return to the beginning of the current title.

P- twice briefly to return to the previous title.



Finish playing.



Show detailed information.









Exit DivX menu.

See page 30 onwards for other operating functions.

DivX subtitles

For subtitles to be displayed correctly press **MENU – LANGUAGE – Disc Subtitles** and select the desired subtitle language.

To select the correct character set for the subtitles, press the red button     during play-back and then select the desired character set with  .

The subtitles function can be switched on and off like on DVD-Video (page 33).

About DivX Video files

This recorder is compatible with the following DivX formats:

- The maximum picture resolution of the DivX file is less than or equal 720 x 576 (H x V) pixels.
- The filename of the DivX file has a maximum of 47 characters.
- Characters in DivX filenames which cannot be displayed are shown as “_”.
- The unit can not correctly play image refresh rates of > 30 images per second.
- If the sound and picture are out of sync, either the sound or the picture is played.
- This recorder does not support the “GMC” DivX/Xvid function.
- Valid DivX file extensions for videos are: “.avi”, “.divx”.
- Valid DivX file extensions for subtitles are: “.smi”, “.srt”, “.sub” (only Micro DVD, Subviewer 1-2 formats), “.txt” (only Micro DVD, T1-4 formats). Other subtitles cannot be displayed.
- Valid DivX Codec formats: “DivX3.xx”, “DivX4. xx”, “DivX5.xx”, “XVID”, “3IVX”.
- Valid DivX Audio formats: “Dolby Digital” (AC3), “PCM”, “MP2”, “MP3”, “DTS (only at DIGITAL OUT)”, “WMA”.
- MP3 sampling rates: 8 - 48 kHz.
- WMA sampling rates: 32 - 48 kHz.
- MP3 bit rates: 32 - 320 kbps.
- WMA bit rates: 32 - 192 kbps.

Audio mode

Playing titles on Audio CD or MP3/WMA media

Audio CDs can be played with the recorder. Recordings in MP3/WMA format can also be played from HDD, memory card, CD-ROM, CD-R or CD-RW discs (read the instructions for MP3/WMA recordings on page 36 before playing MP3/WMA recordings).



Open the disc drawer.

Insert the selected disc in the drawer with the side to be played facing down.



Close the drawer.



Call main menu.

◀ ▶ Select **MUSIC**.

▲ ▼ Select **HDD / DISC / Memory Card 1/2**.

Confirm selection with **OK**. The **Music List** menu appears on the screen.

AUDIO CD menu

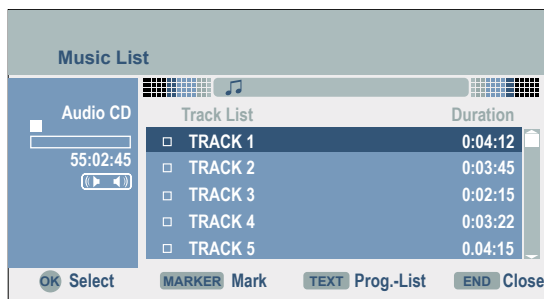

MP3/WMA menu



▲ ▼ Select title.



Start **Play**.

The elapsed playing time of the current track/current file is displayed on the left.

Playing stops automatically at the end of the disc/list.



Change between program and original list.



Display detailed information (only MP3/WMA).



Finish playing.

Options in the music menus



▲ ▼ Select title or folder.

OK display menu options.

▲ ▼ Select option.

Confirm with **OK**.

New album Create new folder.

Play Starts playing the selected tracks/files.

Random Random play-back order of the tracks/files.

Program add Inserts track/file in the program list (page 37).

Copy Copy files to folder or data medium (page 36).

Move Move files to folder or data medium (page 36).

Open Open folder and show contents.

Delete Deletes selected title/folder.

Rename Change file/folder name.

Pause



Pause playing.



Continue playing.

Play another title



P+ or **P-** during play-back to select the next title or return to the beginning of the current title.

P- twice briefly to return to the previous title.



Enter the track number of the desired title directly with an Audio-CD.

Search CD



Switch on seek mode during play-back.

Select the search direction and speed:



x2, x4, x8 (reverse).



x2, x4, x8 (forwards).

Search speed and direction are displayed.



End search mode and continue playing.

Audio mode

Random play



▲ ▼ Select title or folder.

OK display menu options.

▲ ▼ Select **Random**.

Confirm with **OK**. The random play-back starts and the symbol is displayed: **Random**.

Skip the current title with **P+**.

Hints for MP3/WMA recordings

- Sampling rates: MP3: 8 - 48 kHz; WMA: 24 - 32 kHz.
- MP3 bit rates: 32 - 320 kbps.
- WMA bit rates: 32 - 192kbps.
- An MP3 file consists of audio data compressed with the MPEG1 Audio Layer-3 file coding.
- A WMA file (Windows Media Audio) consists of data which have been compressed with the Windows Media Codec.
- The filenames must have the extension ".mp3" or ".wma".

Compatibility of MP3 discs

- The physical format of the CD-R must conform to ISO 9660 and JOLIET.
- The physical format of the DVD+R/RW must correspond to ISO 9660 (UDF Bridge-Format).
- The total number of files in a folder on the disc may not exceed 1999.

➡ **Please note that permission is required for downloading MP3/WMA files and music from the Internet. The required permission must be obtained from the respective copyright owners or their representatives.**

Copy/move files/folders

Files and folders can be copied or moved to other data media depending on the medium.

➡ Switch off the memory card's write protection.

➡ Check whether the memory medium has enough free capacity.



▲ ▼ Select file or folder.

Confirm with **OK**. Display menu options.

▲ ▼ Select **Edit**.

▶ Call second level.

▲ ▼ Select **Copy / Move**.

Confirm with **OK**.

The **Copy** or **Move** menu appears.

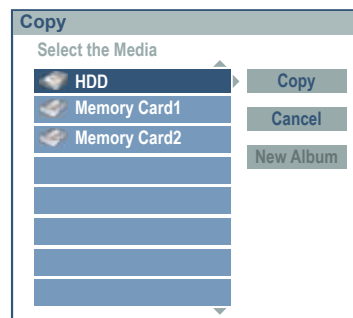

▲ ▼ Select the folder on the memory medium.

or create a new folder with **New Album**.

▶ ▲ ▼ Select **Copy / Move**.

Confirm with **OK**.



The selected files / folders are copied to the memory medium into the selected folder.

Cancel returns to the start menu.

Audio mode

Program list

With the program list you can put together your favorite titles on a memory medium in any order for your individual program. This list may contain 99 titles (Audio CD) or 256 titles (MP3/WMA). Program lists can be saved permanently, renamed, deleted and loaded as often as you like.

-  ▲ ▼ Select title or folder.
-  Mark title or folder. A symbol (✓) appears in front of the title/folder. Repeated pressing marks other titles/folders.

➡ If a folder is selected, all the files in it are added to the program list.

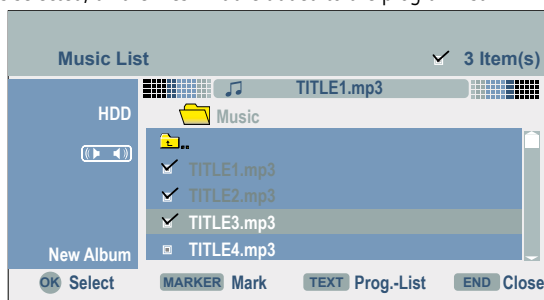

OK display menu options.

▲ ▼ Select **Program add** to add title to program list.

Confirm with **OK**.

◀ ▶ Change to program list.



▲ ▼ Select first title of the program.



or **OK** start playing in the programmed order.



Change between program and original list.

Options in the menu Program List



▲ ▼ Select title or folder.

OK display menu options.

New album Create new folder.

Play Starts playing the titles in the programmed order.

Random Random play-back order of the titles.

Delete Deletes selected title/folder/program list.

Move Move order of the selected title in the program list.

Save Saves the program list you have just created in the **PROGRAM** folder in the main directory of the hard disc (*HDD*).

Program add Inserts track/file in the program list.

Load Load saved program list.

Rename Change name of program list.

Repeat programmed tracks/files

 Select type of repetition during play-back.

TRACK Repeats the current title.

ALL Repeats all tracks (*CD*).

FOLDER (MP3/WMA) repeats all files in the current's folder.

Delete title from the program list



▲ ▼ Select title.

 Mark title. A symbol (✓) appears in front of the title.

OK display menu options.

▲ ▼ Select **Delete**.

Confirm with **OK**.

Change track/file order in the program list

▲ ▼ Select title to be moved.

 Mark title. A symbol (✓) appears in front of the title.

OK display menu options.

▲ ▼ Select **Move**. A blue bar appears in the program list.

▲ ▼ Move bar to desired position.

OK perform movement.

Photo mode

Show photos

The recorder can display JPEG files under the following conditions. The maximum size of a JPEG file may not exceed 4 MB. The total number of files and folders is 1999. The file extension must be ".jpg". The progressive and loss-free compression of JPEG files is not supported.

ASSIST

Call main menu.

◀ ▶ Select **PHOTO**.

▲ ▼ Select **HDD / DISK / Memory Card 1/2**.

Confirm selection with **OK**.

The **Photo List** menu appears on the screen.

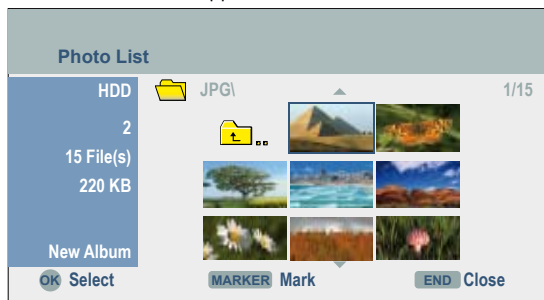

▲ ▼ ◀ ▶ Select desired photo.

OK display options.

▲ ▼ Select **Full Screen**.

Confirm with **OK**. The photo is displayed.

➡ If the thumbnail is displayed in black, this JPEG file cannot be displayed.



OK hide / show menu bar.

Go to previous / next photo with **P-** / **P+**.

▲ ▼ Rotate photo 90° to left / right.



Exit photo display, return to **Photo List** menu.

Options in the "Photo List" menu

New Album Create new folder.

Open Open folder and show contents.

Full Screen Show photo.

Delete Delete file(s)/folder.

Slide Show Automatically running photo sequence.

Rename Change file/folder name.

Move Move files to folder or data medium (page 36).

Copy Copy files to folder or data medium (page 36).

Slide Show

▲ ▼ Select Slide Show option in the **Photo List** menu.

Confirm with **OK**. The **Slide Show** menu appears.

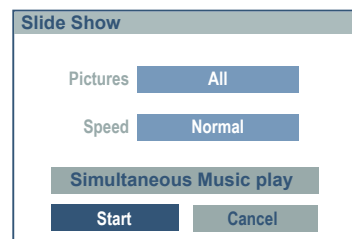

▲ ▼ ◀ ▶ Select options and confirm with **OK**.

Pictures Display **Selected** files * or **All** files.

Speed Speed of the slide show: **Slow**, **Normal** or **Fast**.

Simultaneous Music Background music selectable from HDD.



* You can put together the slide show and simultaneous music individually by selecting individual files with the **MARKER**  button.

▲ ▼ ◀ ▶ Select **Start** button.

OK start slide show.



Stop slide show.



Continue slide show.



End slide show, return to Photo menu.

Card-Reader mode

About the system

With the digital audio/photo card reader integrated in the recorder, you can show photos taken by digital cameras on the screen with the most common memory cards. MP3/WMA audio files can be played. You can operate the Audio/Photo Card reader with the remote control of the Loewe recorder.

MP3 or JPEG files can be copied from a data-CD/DVD to a memory card or an HDD with sufficient free capacity (page 36).

Compatibility of the memory cards

The memory card must be formatted in FAT 12, 16 or 32 format. Memory cards with other formats cannot be read.

Formats of the memory cards

Memory Stick (MS)	Memory card 2
Memory Stick Pro	Memory card 2
MultiMediaCard (MMC)	Memory card 2
Secure Digital (SD)	Memory card 2
xD-Picture Card	Memory card 2
Compact Flash (CF)	Memory card 1
Micro Drive (MD)	Memory card 1

To avoid compatibility problems, only use high quality memory cards from brand name manufacturers.

Maximum memory capacity

Compact Flash (CF)	4 GB
Micro Drive (MD)	5 GB
Memory Stick (MS)	128 MB
Memory Stick Pro	1 GB
MultiMediaCard (MMC)	1 GB
Secure Digital (SD)	1 GB
xD-Picture Card (xD)	512 MB

➔ When activating the audio/photo card reader, the Recorder should be idle, with no additional screen displays (no menu or Picture In Picture display).

➔ Take care with the card's polarity / tag (see diagram).

➔ Keep memory cards out of reach of children. If swallowed, a doctor is required immediately.

➔ Cards should not be touched with electrical contacts, or the memory may be damaged.

➔ Only one card at a time may be plugged in the memory card slot 1.

➔ For formatting of memory cards, please see "M/C Format" on page 21.

➔ The reading time of the memory card depends on the number of files, the file size or resolution.

➔ If a folder on the memory card contains more than 645 files, not all the files can be played.

➔ The card in the slot1 has priority when cards are inserted in both memory card slots. To activate the card in the left hand memory slot, remove the card from the right hand slot.

➔ The front flap on the recorder cannot be closed while one or both memory cards are plugged in.

Inserting/removing memory cards

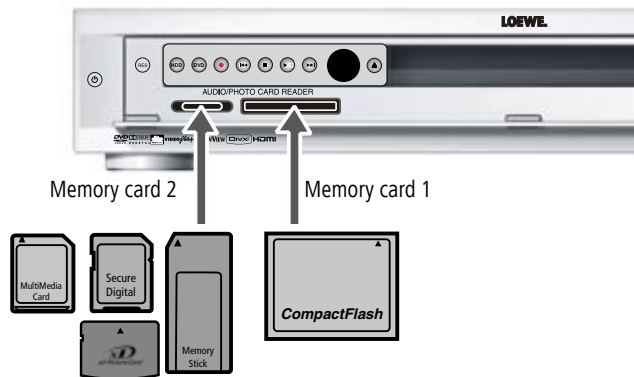

Inserting card Open the front flap.
Insert card until it snaps in.

Removing card Press the card lightly in the middle at the front until it is released (memory card 2) and then remove the card carefully (both memory cards).

Audio mode

See "Audio mode" on page 35 for operation.

Photo mode

See "Photo mode" on page 38 for operation.

Remote control Assist – Card-Reader operation

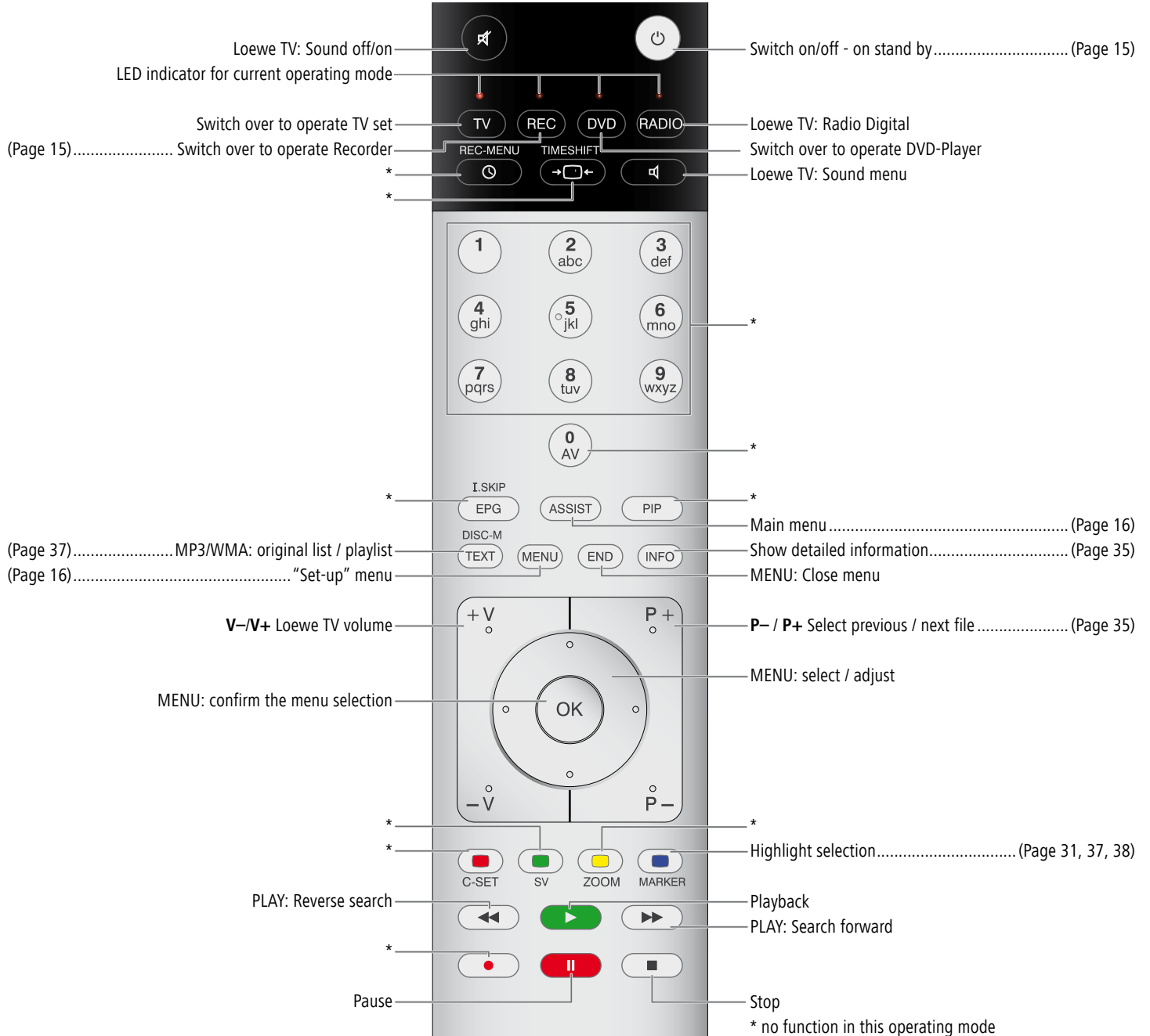

Recording

Recordings on the HDD

Recordings on the internal hard disc (HDD) of the recorder are similar to recording in the VR mode on DVD-RW discs. Ten genres can be assigned to the recordings for easier management (see "Title Name", page 50).

- ➡ The maximum number of titles on the HDD is 255.

Delayed TV viewing – Timeshift mode

You can interrupt a TV program at any time and continue watching it later with a timeshift.

Set the recorder to the desired signal source as described under "Manual Record" (page 42).

- ➡ The timeshift operation only starts when the TV option is set to **TV HDD** in the main menu (page 16).



Start recording with **TIMESHIFT** (**BUFFERING** appears briefly in the display window of the DVD recorder and the **T/S HDD** display lights up). The display for Timeshift appears.



- 1 Status display for play mode.
- 2 Timeshift start time.
- 3 Already elapsed Timeshift time.
- 4 Current Timeshift time.
- 5 Timeshift start time plus one hour.



Interrupt recording. Press  again to continue.



Switch Timeshift display on / off.

- ➡ The display for Timeshift disappears after 10 seconds. A symbol appears for this in the bottom left of the screen: 

The display can be called again with **OK**.

Markers in Timeshift

A marker can be set in Timeshift mode.



Press the blue button briefly to set a mark at a selected point.

Press the blue button long to select the marked scene.



Exit display.

Clip recording

A program can be saved permanently on the HDD during the Timeshift display.

Search for the starting point with single frame, search and slow motion (page 30).



Press at the starting point of the clip to be recorded.



The progress of the recording is shown red in the progress display.

Search for the end point with single frame, seek and slow motion.



Press at the end point of the clip to be recorded.

Playing continues. Repeat the procedure for other clips if necessary.

- ➡ The display for Clip recording disappears after 10 seconds. A symbol appears for this in the bottom left of the screen: 

- ➡ Only the sequences selected by clip recording are saved permanently on the HDD.

- ➡ Clip recordings are not possible for sequences shorter than five seconds.

Jump to start or end during Timeshift



The display appears.



◀ Start playing from Timeshift starting point.

▶ Start playing from Timeshift end point.

◀ ▶ Jump back/forward 5 minutes during playing.



Jump forward 15 seconds during playing.

Exit Timeshift



End recording.

A confirmation message is displayed.

◀ ▶ Select **yes**.

Confirm with **OK**. The current TV program is displayed.

Recording

Simultaneous record and display

Playing another medium during recording

Play and record take place independently of each other for DVDs and the integrated HDD. For example, you can record on a DVD or the HDD and at the same time play a movie, photos or music from the respective other memory medium (except Timeshift, DivX).



Start recording.



Call main menu.

◀ ▶ Select **MOVIE, PHOTO, MUSIC**.

▲ ▼ Select desired memory medium.

Confirm selection with **OK**.



Start play-back.

The recording is continued during play-back from the other data medium.

⇒ Some functions (e.g. simultaneous play and recording when dubbing) are not possible.

Time Slip

HDD

Time Slip enables delayed playing of the title while it is being recorded.



Start recording.



Start play-back.

Playing starts whilst recording continues.



◀ ▶ You can navigate during play-back with single frame, seek and slow motion.



End play and display current recording position.

⇒ Playing can start at the earliest 15 seconds after starting the recording.

⇒ This function is not available in the DVD recording mode.

Manual Record

Proceed as follows to make video recordings.

Switch on the recorder. Insert a rewritable disc for DVD recordings. If you insert an empty disc, the recorder will initialise it automatically first (page 26).

If required, select **Rec mode Set** (page 25)

Call main menu.

◀ ▶ Select **TV**.

▲ ▼ Call **TV HDD** or **TV DVD**.

Confirm selection with **OK**. A status information to the selected memory medium is displayed briefly.



Switch the recorder input to the signal source you wish to record from with the number buttons, the **P+** / **P-** buttons or the **0 AV** button. The station number, name and current sound status are displayed on the screen.



Then select the sound channel ("TV Audio" page 25).

Start recording. (**REC** lights up in the display window of the recorder). The recording starts immediately and continues until the disc is full or you interrupt the recording.

10M Rec
80H 19M Free



During recording. Show remaining recording time. By pressing the button again the maximum recording time is limited to a fixed period of time. Every additional press of a button extends the recording time by 10 – 30 minutes to a maximum 4 hours.



Interrupt recording. Press again to continue.



Show status of recording.



End recording.

⇒ If the recorder is disconnected from the mains during recording (or in case of a power failure) or the recording is interrupted manually with the On-Off button, the whole recording is lost.

Recording

Timer Recording

This recorder can be programmed to record up to seven programs within one month. For programmed recordings the timer must be informed which signal sources (TV stations or from AV devices) are to be recorded and the respective start and stop time.

Switch on the recorder. Insert a rewritable disc for DVD recordings.



Call the **Timer Record** menu.

Timer Record		SQ 80H 9M Free					
Media	PR	Date	StartTime	EndTime	Repeat	VPS/PDC	
HDD	31	8/12 Fr	20:15	22:00	Once	Off	
S23 K1		Duration : 105 M					
REC-MENU		Timer Record List		OK Enter		END Close	

Media Select the memory medium for the recording.

PR Select the stations or an external input.

Date Select the data up to one month in advance.

Start time Defines the start time for the recording.

End time Defines the end of the recording.

Repeat Select repetition (once, daily (Mo-Fr), weekly).

PDC The VPS/PDC system adapts the recording time automatically to changes in the program start time for recordings via the integrated tuner. Set the VPS/PDC time and the date of the program you want to record. You will find these in your TV guide or in the teletext.

Enter the necessary information for your timer recording(s).

◀ ▶ Move the cursor to the previous / next column.

▲ ▼ Edit the setting at the current cursor position.

OK saves timer data.



Exit **Timer Record** menu without saving.



Call **Timer Record List** menu.



Switch recorder to standby.



End recording.

A confirmation message is displayed.

Confirm with **OK**.

► The recorder must be in standby mode for timer recording to start automatically.

► Please note that not every station operates with VPS/PDC.

► The starting time for the recording must be at least 3 minutes into the future. The recorder switches on about 2 minutes before the programmed time and runs up to about 2 minutes after the programmed time.

► The current time and the current date must be set in the recorder (page 20).

► The energy saving function must be switched off (page 21).

► Select the audio channel for two-language TV recordings in the "TV Rec Audio" menu (page 25).

► In standby mode the Timer symbol lights up in the display window when a timer recording is programmed (page 4).

Timer recordings with the ShowView® system

Programming timer recordings with this system is child's play. Most television schedule publications include the ShowView code numbers along with the information about the programmes. So when you want to make a timer recording of a programme, you only need to key in the appropriate ShowView code number. The date, start time, end time and station are set automatically. You only need to set the recording quality and specify whether it is to be a one-off or repeated recording. You can save up to seven timer programmes on the recorder.

◻ ◻ ◻ ◻ ◻ ◻ ◻ ◻ Select **ShowView** menu with the green button.

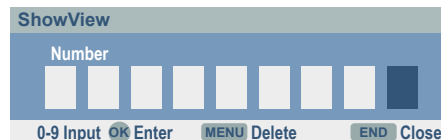

Enter the ShowView number.

Delete input errors.

Confirm with **OK**. The **Timer Record** menu appears.

Check and, if necessary, correct the settings as described under "Timer Recording" (this page).

Recording

Timer Record List

Checking the timer programming



Press twice to call the **Timer Record List** menu.

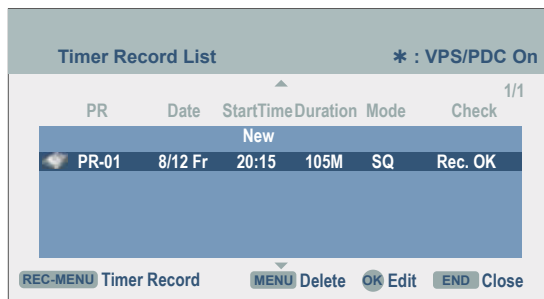

Editing a timer programming



▲ ▼ Select timer recording.

OK edit selected programming.



Delete selected programming.



or **New** opens "Timer Record" menu (page 43).

Recording conditions

With the programmed timer the recorder does not record under the following conditions:

- No disc or a non-rewritable disc inserted. The recording is then made on the HDD.
- The power supply is interrupted or the recorder is not ready.
- There are already 99 recorded titles on the disc.
- The starting time for the recording is less than three minutes into the future.

You cannot program the timer under the following circumstances:

- A recording is already in progress.
- Seven timer recordings have already been programmed.

Multiple overlapping timer programs:

- The earlier recording takes priority.
 - When the earlier recording ends, the later one will start.
- ➡ If the disc is damaged, it is possible that the recording will not be done properly. Even if the "Rec. OK" message appears in the "Check" field, this is not necessarily true in this case.

Record from external sources

You can record from an external source (e.g. SAT-TV set, SAT receiver, camcorder or video recorder).

The device you want to record from must be connected to the recorder properly. You will find further information on page 13.

Switch on the recorder and set the desired memory medium under TV in the main menu. Insert a rewritable DVD if necessary.



Select source.

- AV1** EURO AV1 AUDIO VIDEO to the rear of the housing.
- AV2** EURO AV2 DECODER to the rear of the housing.
- AV3** AUDIO AV IN 3 / VIDEO IN 3 to the rear of the housing.
- AV4** AUDIO IN 4 / VIDEO IN 4 / S-Video IN to the front of the housing.
- DV** DV IN to the front of the housing.
- PR-nn** Integrated tuner on station nn.

Set the recording quality (page 25).

For further operation see "Manual Record" on page 42 or "Timer Recording" on page 43.

➡ If you operate this recorder with a Loewe Flat-TV set, the recording wizard of the TV set controls the recording via Digital Link Plus. This has the advantages of easier operation, especially when recording digital stations. You will find further information in the TV user guide under "Operation of additional equipment – Timer recordings".

➡ If your source is copy-protected by Copy-Guard, you cannot use this recorder to record from it. Read the copyright notes on page 10.

Digital Video

General "DV" information

With DV (Digital Video, also known as i.LINK), you can use a DV cable as the audio, video, data and control signals input / output to connect a camcorder that has DV to this recorder. The i.LINK interface complies with the IEEE 1394-1995 standard. "i.LINK" and the "i.LINK" logo are trademarks.

- This recorder is only compatible with "DV 25" format camcorders. Digital satellite tuners and digital VHS video recorders are not compatible.
- You cannot connect more than one DV cam-corder at a time to this recorder.
- You cannot control this recorder with external devices that are connected via the **DV IN** socket (incl. two Recorders).
- The camcorder connected via the **DV IN** socket cannot necessarily, in every case, be controlled.

Recording

- Digital camcorders can usually record audio as 16 bit/48 kHz stereo or twin stereo tracks with 12 bit/32 kHz. This recorder can only record one stereo audio track. Set "DV Rec Audio" as required or Audio 1 or Audio 2 (page 25).
- The sampling rate of the digital sound input to the **DV IN** socket must be either 32 or 48 kHz (not 44.1 kHz).
- Recording may suffer from interference if the camcorder stops playing back, if a part of the tape that has not been recorded on is played back, if the electricity supply to the camcorder is cut off, or if the DV cable comes out.
- When "DV Rec Audio" is set to "Audio 2" and there is no Audio 2 signal, "DV Audio" will automatically be set to "Audio 1".

DV messages

When you are using the **DV IN** socket, the following messages may appear on the screen.

Not connected to camcorder: The camcorder is not properly connected, or the camcorder is switched off.

Too many devices connected: This recorder's DV socket only supports the connection of one camcorder.

Check tape: There is no tape in the device that is connected.

Incompatible device: The recorder is unable to control the camcorder.

Information is being reloaded: The camcorder is updating data for DV.

Camera mode: The camcorder is set to camera mode.

Troubleshooting

If you are not receiving images and/or sound via the DV IN socket, check the following:

- The DV cable must be properly connected.
- Switch off the camcorder that is connected, and switch it back on.
- Tune the audio input in to the recorder.
- ➡ This recorder cannot necessarily control every camcorder that is connected to it.

Recording from a digital camcorder

You can record from a camcorder that is connected to the **DV IN** socket in the recorder's front panel. You can use the recorder's remote to control a camcorder and the recorder. Before recording, make sure that the audio input has been set up for the DV IN socket (page 25).

The digital camcorder must be connected to the DV IN socket at the front of the housing. Further information can be found on page 15.

You can choose from between Audio 1 (original audio) and Audio 2 (overdubbed audio).

The DV input is set using the "DV Rec Audio" submenu of the main menu (page 25).

Select DV input.

"DV" is displayed in the display window of the recorder and on the screen.

Search the position on the camcorder tape from which you want to record.

For optimum results, interrupt play-back of the camcorder at the point from which you want to record. Depending on the camcorder you can operate the functions **STOP**, **PLAY** and **PAUSE** with this recorder.

Start recording.

The recording is stopped automatically when the recorder detects no signal.

Interrupt recording. Press again to continue.

End recording.

➡ You cannot use the recorder to control the camcorder while recording is in progress.

➡ In Video mode, the last frame of the recording is shown on the screen for a short time after recording has ended.

➡ For timer recordings to work properly on this recorder, the digital camcorder should be switched on and operational.



Edit recordings

Menu Title List and Chapter List

Under the Title List menu, video contents on unfinalised DVDs in VR mode and video contents on the internal HDD can be edited. The available edit functions are dependent on whether video on a DVD in VR mode or on the HDD or whether original contents or playlists are edited.

DVD-RW discs in VR-mode can be edited in two ways. Original contents of the disc can be edited directly or a playlist can be created and edited. The playlist does not change the contents of the disc but controls its play-back.

The editing of recordings on the HDD is the same as editing of original contents of a DVD-RW in the VR mode. Similar commands for deleting and naming titles as well as a fine setting of the chapter contents within the titles are available.

► If the Title List menu of the HDD is displayed during recording, some titles may have a marker. These titles have been recorded with a different input setting to the current recorder setting. These titles cannot be played during the recording.



Pause playing.



Select **Title List** menu.



▲ ▼ ◀ ▶ Select title.



Change between Original and Playlist menu when editing in DVD VR mode.

The available options are displayed at the left. The titles (or chapters) on the DVD or HDD are displayed on the right of the screen. The thumbnails can be edited. (See "Change title thumbnail" on page 47).



Information about the selected title in the Title List menu.



Close menu.



1. Different menu options are displayed depending on the memory medium.
 - Combime** Connects two titles or chapters as one (page 51).
 - Delete** Deletes the title or the chapter (page 49).
 - Delete part** Deletes part of the title (page 49).
 - Divide** Divides a title into two (page 52).
 - Dubbing** Copies the title to another data medium (page 55).
 - Full Play** Starts playing the selected title including hidden chapters.
 - Hide** Hides (shows) the selected title or the chapter (page 53).
 - Move** Moves a chapter in the Chapter List / Playlist menu to another position (page 53).
 - Play** Starts playing the selected title or chapter. Hidden titles and chapters on the DVD+R/RW are not played.
 - Playlist Add** Adds the title or chapter to a new playlist (page 47).
 - Protect** Prevents accidental recording, editing or deleting of a title (page 53).
 - Title Name** Edits the title name; assignment to genre (page 50).
 - Search Chapter** Display Chapter List of title (page 50).
 - Search Time** Time at which title starts playing (page 50).
 - Sort** Sorts the title list according to date, title or genre (page 51).
 - Title** Displays the title list of the chapter.
 - Undo /** Undo last deletion or
 - Redo** Redo (page 51).
2. Displays the recording quality, free memory space and a progress display of the elapsed playing time.
3. Name of the current memory medium.
4. Currently selected title.
5. Thumbnail.
6. Shows the title name, the recording date and the length of the recording.

Edit recordings

Edit Original and Playlist

Title, Chapter and Parts

Titles of the original content of the disc contain one or more chapters. When inserting a title in the playlist, all the chapters within this title also appear. That means that chapters in the playlist behave exactly the same as chapters on a DVD-Video disc. Parts are sequences of the original or playlist titles. Parts can be added to or deleted from the Original and Playlist menu. When adding a chapter or title to the Playlist, a new title is created consisting of a sequence (= chapter) of an original title. When deleting, part of the title of the Original or Playlist menu is deleted.

➡ If you use the Delete, Edit and Move functions, the start and end frames may not correspond exactly with the start and end points. A short pause may be made between edits during play-back of the playlist. This is not a malfunction.

Original and Playlist

-RW VR

The terms Original and Playlist are used in this user guide for the actual contents and the edited contents.

Original The contents of the actual recordings on the disc.

Playlist On DVDs a "Playlist" of the contents to be played and the play times is created for editing. The recorder plays the disc according to the playlist.

Add chapter markers

HDD -RW VR +RW +R

Chapters can be created by inserting chapter markers at the desired positions within a title.

 **C-SET** During recording or playing at the position at which a new chapter is to be inserted.

A chapter marker symbol appears on the screen.

➡ Chapter markers are inserted automatically at regular intervals. You can change these intervals in the "Recording" menu (see "Auto Chapter" on page 25).

Create new Playlist

-RW VR

Use this function to add an original title or a chapter to the playlist. The whole title is added to the playlist (you can delete parts you will not need later; see "Delete title/chapter from Original/Playlist" on page 49).

The title appears in the playlist together with the chapter markers of the original. When adding other chapter markers to the original later, however, these are not copied automatically to the titles of the playlist. You can add a maximum 999 chapters to a disc. To add only one chapter of a title, read "Add title/chapter to Playlist" on page 48.



Select Title List/Chapter List Original menu.

▲ ▼ ◀ ▶ Select title/chapter.

Confirm with **OK**.

The available options are displayed at the left.

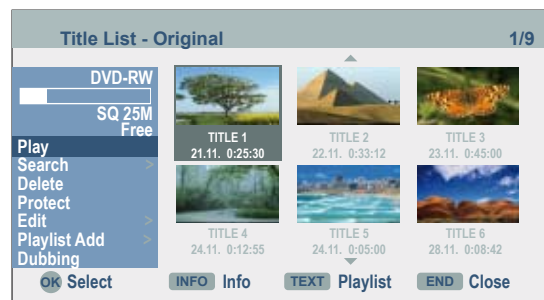

▲ ▼ Select **Playlist Add**.

Confirm with **OK**.

Edit recordings

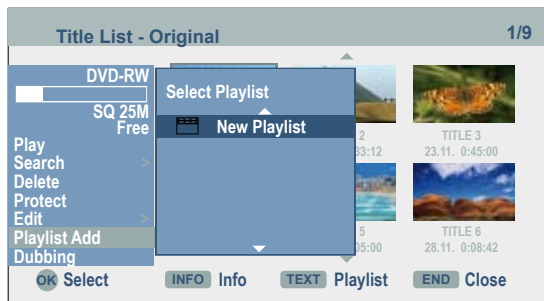

▲ ▼ Select **New Playlist**.

Confirm with **OK**.

The new title appears in the updated Playlist. All chapters of the title are added to the Playlist.

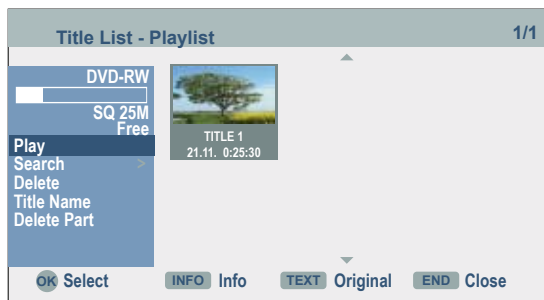

Add title/chapter to the Playlist

-RW VR

You can add an original title or a chapter to a Playlist title even if it is already registered.



▲ ▼ ◀ ▶ Select a title/chapter in the Title List Original or Chapter List Original menu which is to be inserted in the Playlist.

Confirm with **OK**.

The available options are displayed at the left.

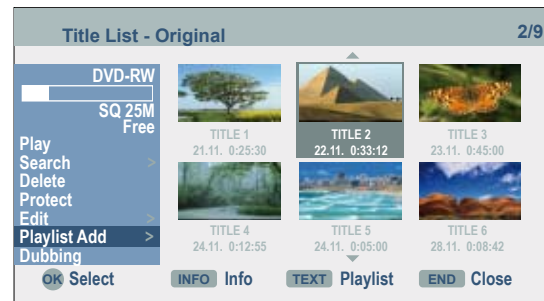

▲ ▼ Select **Playlist Add**.

Confirm with **OK**.

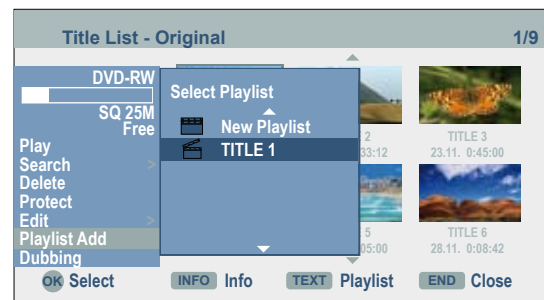

▲ ▼ ◀ ▶ Select Title List Playlist in which a title or chapter is to be inserted.

Confirm with **OK**.

The added chapters are displayed in the menu (**Search - Chapter**) **Chapter List - Playlist**.

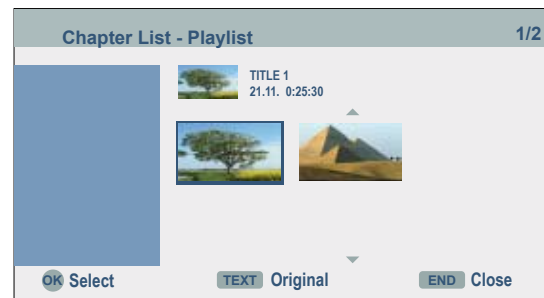

End editing of the Playlist.

Edit recordings

Delete title/chapter from Original/Playlist

When you delete a title or a chapter from the playlist, you only remove the title/chapter from the playlist.

When you delete a title or chapter from the original list, title/chapter are deleted from the disc and the time remaining for recording is prolonged again. Titles or chapters deleted from the original are also deleted from the playlist.

- ➡ You cannot delete chapters with a playing time of less than 5 seconds.



▲ ▼ ◀ ▶ Select a title/chapter in the menu **Title List - Original** or **Chapter List - Original** which is to be deleted from the playlist.

Confirm with **OK**.

The available options are displayed at the left.

▲ ▼ Select **Delete**.

Example: **Title List (HDD)**:

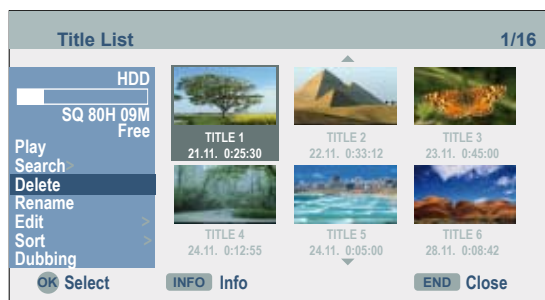

Confirm with **OK**. A delete prompt is displayed.

▲ ▼ Select **yes**.

Confirm with **OK**. The chapter or title is deleted.

OK displays the updated menu.



End editing.

- ➡ For DVD+R/DVD+RW recordings the deleted title is renamed after "Deleted Title".

- ➡ In case of fast deleting of more than two titles in succession, the titles are combined as one.

- ➡ When deleting a title or chapter, the remaining recording time is increased on the DVD+RW only by the size of the title which was deleted at the end.

Delete part

HDD -RW VR

You can delete a part which you no longer want in the title.



▲ ▼ ◀ ▶ Select title in the Title List menu.

Confirm with **OK**.

The available options are displayed at the left.

▲ ▼ ▶ Select **Edit – Delete Part**.

Confirm with **OK**.

The **Edit** menu (Delete Part) is displayed.

The **Start point** symbol is marked.

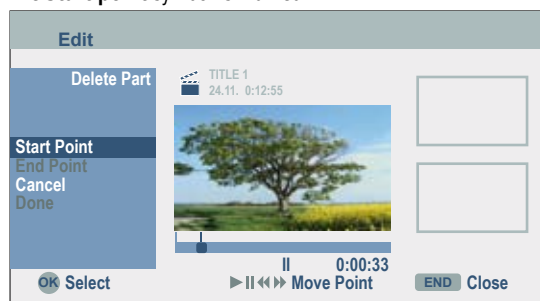

◀ ▶ Start play-back and search the start point with single frame, search and slow motion.

OK at the start point of the clip to be deleted.

The **End point** symbol is marked.



◀ ▶ Search the end point with single frame, search and slow motion.

Confirm with **OK**.

- ➡ Other parts can be deleted in recordings on the HDD. Select **Next Part** in the menu, press **OK** and repeat the steps described above.

▲ ▼ End editing with **Done**.

Confirm with **OK**. A delete prompt is displayed.

◀ ▶ Select **yes**.

Confirm with **OK**. The selected part is deleted from the title.

◀ ▶ Select **Cancel** to reject the editing.

Edit recordings

Title Name

You can assign names to the titles of Original or Playlist. The names may have a maximum 32 characters. A genre can be added to the name (*HDD*).

▲ ▼ ◀ ▶ Select title to be renamed in the **Title List** menu.

Confirm with **OK**. The available options are displayed at the left.

▲ ▼ Select **Title Name/Rename**.

Confirm with **OK**.

The **Keyboard** menu is displayed.



Explanations of the options:

Alphabet Capital Switches the keyboard to capitals.

Alphabet Small Switches the keyboard to small letters.

Symbol Switches the keyboard to special characters.

ABC...123 Inserts the selected character at the cursor position (shaded grey for special characters).

OK Save setting and exit.

Cancel Exit setting without saving.

Space Inserts a space at the cursor.

Delete Deletes characters to the left of the cursor.

◀ ▶ ▲ ▼ Moves the marker in the selection.

Inserts a space at the cursor.

Deletes the characters to the right of the cursor.

Deletes the character to the left of the cursor.

P+ / P- Moves the cursor to the left or right.

Genre Assigns the title to a genre (*HDD*).

Switches the keyboard back and forth among capitals, small letters and symbols.



Select the **OK** button and save with **OK**.

► On DVD-R-, DVD+R- or DVD+RW discs, the entered name is only displayed after finalisation.

Select title start point

HDD -RW VR -RW Video +RW +R -R

You can select the start point of the title.



▲ ▼ ◀ ▶ Select title in the **Title List** menu.

Confirm with **OK**.

The available options are displayed at the left.

▲ ▼ Select **Search - Time**.

Confirm with **OK**.

The **Search** menu is displayed on the screen.

Example: Title List (*HDD*):

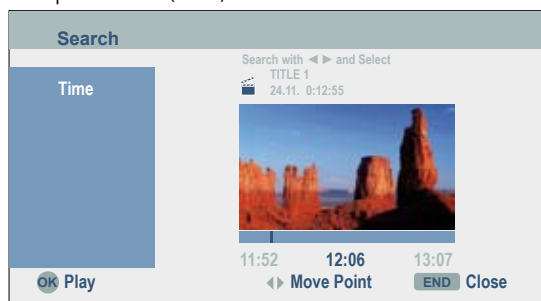

◀ ▶ Select the desired start point.

The time changes in one minute steps.

◀ ▶ Keep pressed to increase the time in steps of 5 minutes.

OK to start at the desired point.

Select chapter

HDD -RW VR -RW Video +RW +R -R

You can select any chapter from a title.



▲ ▼ ◀ ▶ Select title in the **Title List** menu.

Confirm with **OK**.

The available options are displayed at the left.

▲ ▼ Select **Search - Chapter**.

Confirm with **OK**.

The **Chapter List** menu is displayed.

▲ ▼ ◀ ▶ Select desired chapter.

OK to start at the selected point.

Edit recordings

Sorting

HDD

With this function the title list can be sorted by date, title or genre for quicker retrieval of titles.



▲ ▼ ◀ ▶ Select title in the Title List menu of the HDD.

Confirm with **OK**.

The available options are displayed at the left.

▲ ▼ Select **Sort**.

Confirm with **OK**.

The options for sorting are displayed.

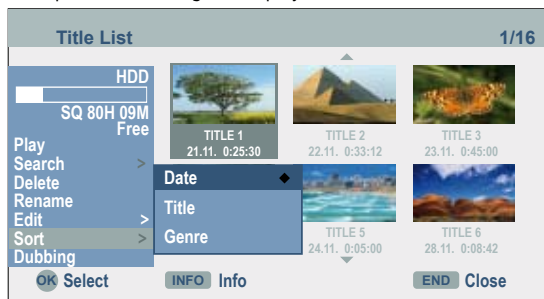

▲ ▼ Select **Date**, **Title** or **Genre**.

OK Display menu with selected sorting.

Undo/redo deletion

-RW VR

Errors when deleting can be undone. Only the last action (i.e. one deletion) can be undone.



▲ ▼ Select **Edit - Undo**.

Confirm with **OK**.

It makes no difference whether you are in the menu screen. The last deletion is undone.

➡ After ejecting the disc or switching to standby mode no actions can be undone.

➡ A deletion can still be undone after exiting the menu.

➡ With Redo the last undone action can be redone.

Combine titles

HDD

With this function two adjacent original titles on the HDD can be united.

➡ This function is not available if only one title is saved on the HDD.

➡ No titles can be combined if there are more than 60 titles on the HDD.



▲ ▼ ◀ ▶ Select first title of the two titles to be joined in the **Title List** menu.

Confirm with **OK**.

The available options are displayed at the left.

▲ ▼ Select **Edit - Combine**.

Confirm with **OK**.

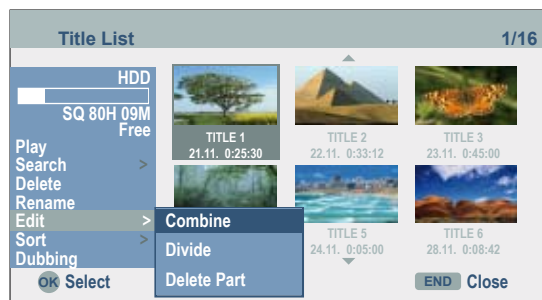

▲ ▼ ◀ ▶ Select second title of the two titles to be joined.

Confirm with **OK**.

A confirmation message is displayed.

▲ ▼ Select **yes**.

Confirm with **OK**. The updated **Title List** menu is displayed.

Edit recordings

Divide title

HDD +RW

With this function you can divide a title into two new titles.



▲ ▼ ◀ ▶ Select title to be divided in the **Title List** menu.

Confirm with **OK**.

The available options are displayed at the left.

▲ ▼ Select **Edit - Divide**.

Example: Title List (HDD):

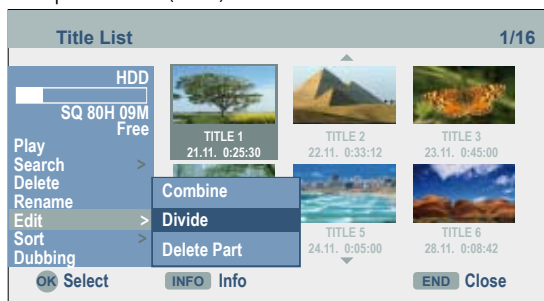

Confirm with **OK**.

The menu **Edit - Divide** is displayed and the **Divide** option is marked.

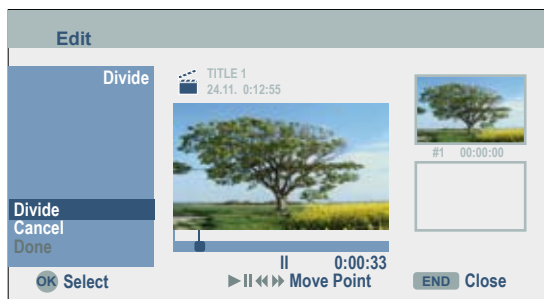

◀ ▶ Seek the start point for dividing the title with single frame, seek and slow motion.



▲ ▼ Select **Divide**.

Confirm with **OK**.



▲ ▼ Select **Done**.

Confirm with **OK**. The title is divided into two new titles. This process may last up to 4 minutes.

➡ Division points must be at least three seconds apart.

Combine chapters

HDD -RW VR +RW +R

With this function two adjacent playlist or original chapters can be united.

➡ This function is not available if the title only contains one chapter.



▲ ▼ ◀ ▶ The second of the two chapters to be united should be selected in the **(Title List - Search - Chapter) Chapter List** menu.

Confirm with **OK**.

The available options are displayed at the left.

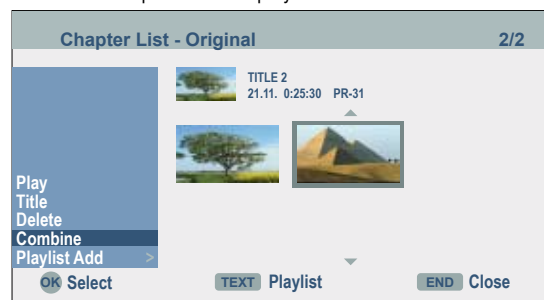

▲ ▼ Select **Combine**. The combination indicator is shown between the two chapters which you can join.

Confirm with **OK**.

Edit recordings

Move Playlists Chapters

-RW VR

With this function the play-back order of the chapters within Playlists can be edited.

► This function is not available if only one chapter is available.



▲ ▼ ◀ ▶ Select chapter in the **Chapter List-Playlist** menu.

Confirm with **OK**.

The available options are displayed at the left.

▲ ▼ Select **Move**.

Confirm with **OK**.

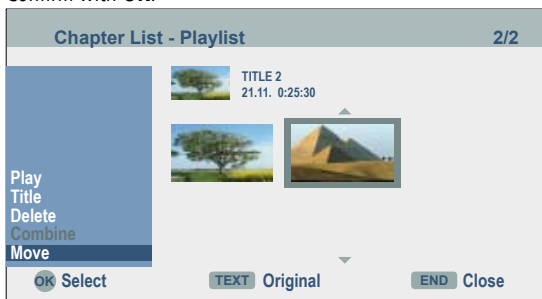

▲ ▼ ◀ ▶ Select position of chapter.

Confirm with **OK**. The updated menu is displayed.

Hide title/chapter

+RW +R

Playing of selected chapters or titles can be skipped by the disc.



▲ ▼ ◀ ▶ Select the chapters to be hidden in the **Title List** or **Chapter List** menu.

Confirm with **OK**.

The available options are displayed at the left.

▲ ▼ Select **Hide**.

Confirm with **OK**. The thumbnail of the chapter or title is hidden.

► When selecting, a hidden chapter or title can be shown in the Title List or Chapter List menu by selecting the **Edit - Display** option in the menu. Then the chapter or title is displayed.

Example: Title List (DVD+RW):

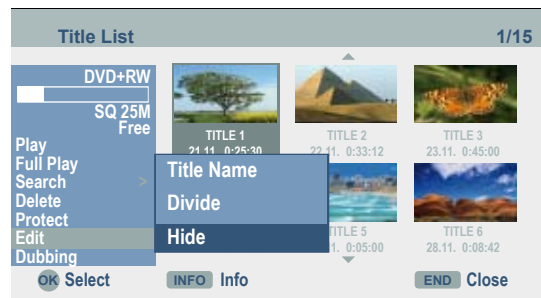

Protect title

-RW VR +RW +R

This function prevents accidental overwriting, editing or deleting of a title.



Select **Title List** menu.

▲ ▼ ◀ ▶ Select the title to be protected.

Confirm with **OK**.

The available options are displayed at the left.

▲ ▼ Select **Protect**.

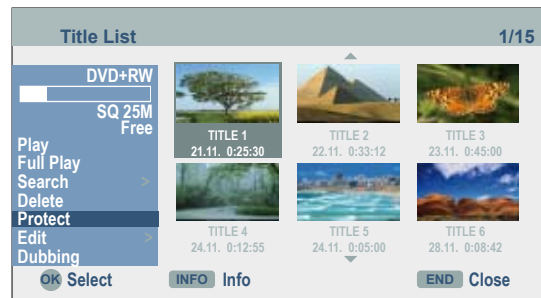

Confirm with **OK**. The lock marker appears in the title thumbnail.

► If you select a title which is already protected in the Title List menu, this can be enabled by selecting Unprotected in the options of the Title List menu. Then the title can be edited and deleted.

Dubbing

Before dubbing

With the dubbing function of this recorder you can

- create backup copies of important recordings on the HDD on a DVD.
- Create a DVD copy of a recording on the HDD for playing on other players.
- Copy movies from a DVD to the HDD for editing.
- Copy edited movies from the HDD to a DVD.

► Titles which are shorter than 5 seconds cannot be copied from HDD to DVD.

Restrictions when dubbing

Some movies have a single copy protection: These movies cannot be copied to HDD or DVD.

Single copy protection movies are recognizable by display of the disc information with **INFO** during play-back.

- Signals in NTSC format from the analog or the DV inputs cannot be recorded correctly with this recorder.
- Video signals in SECAM format (from the integrated TV tuner or analog inputs) are recorded in PAL format.
- Please also see the hints for recording on page 10.

PLEASE NOTE THAT NOT EVERY HIGH DEFINITION DEVICE IS FULLY COMPATIBLE WITH THIS PRODUCT AND THAT ARTEFACTS MAY OCCUR WHEN DISPLAYING THE PICTURE. IF 625 PROGRESSIVE SCAN PICTURE DISPLAY IS FAULTY, WE RECOMMEND SETTING THE CONNECTION TO THE "STANDARD DEFINITION" OUTPUT. PLEASE CONTACT OUR CUSTOMER SERVICE IF YOU HAVE ANY QUESTIONS ABOUT THE COMPATIBILITY OF THE TV WITH THIS RECORDER (page 66).

High-Speed dubbing (maximum 12x)

Dubbing between DVD and HDD is a full digital process and therefore takes place without loss of picture and sound quality. The dubbing process can take place at high speed. When dubbing from HDD to DVD, the dubbing speed depends on the recording quality and the DVD disc used.

Minimum duration for high-speed dubbing

The following table contains the respective minimum duration for dubbing a two-hour movie recorded in SQ mode from HDD to DVD.

Disc type	Disc speed	Dubbing time (recording speed)
DVD-R / DVD+R	16x	6.5 min. (12x)
DVD-R / DVD+R / DVD+RW	8x	8 min. (8x)
DVD-RW	6x	12 min. (6x)
DVD-R / DVD+R DVD-RW / DVD+RW	4x	13 min. (4x)
DVD+R / DVD+RW	2.4x	21 min. (2.4x)
DVD-R / DVD-RW	2x	25 min. (2x)

- The specified times are approximate values.
- The actual dubbing speeds may vary with different disc recordings.
- Even 4x-/6x-/8x-/16x-compatible discs may not be dubbed at maximum speed.
- High-speed dubbing is not always possible with discs initialized on another device.

Dubbing

Dub from HDD to DVD



▲ ▼ ◀ ▶ Select title in the **Title List (HDD)** menu.

Confirm with **OK**.

The available options are displayed at the bottom left.

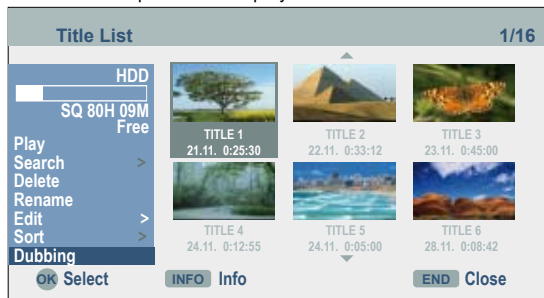

▲ ▼ Select **Dubbing**.

Confirm with **OK**. The **Dubbing** menu appears.



▲ ▼ ◀ ▶ Select **Rec Mode (HQ, SQ, LQ, EQ, AUTO)**.

▼ Select **Start** button.

OK start dubbing.



Cancel dubbing.

➡ The recording time in **Fast** mode may vary depending on the amount of source data.

➡ When aborting the dubbing in **Fast** mode the recording is halted and all the data recorded up to this point are lost.

➡ The **Fast** mode is not possible if there is not enough memory space remaining on the disc.

➡ The **Fast** mode is not possible for edited titles on the HDD and clip recordings.

Dub from DVD to HDD



▲ ▼ ◀ ▶ Select title in the **Title List (DISC)** menu.

Confirm with **OK**.

The available options are displayed at the bottom left.

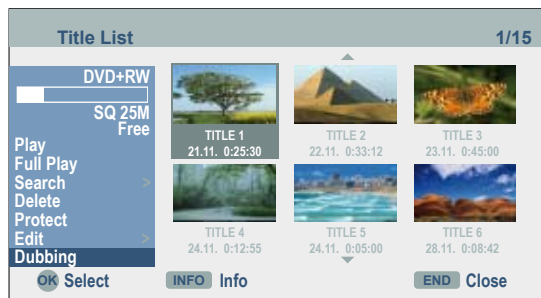

▲ ▼ Select **Dubbing**.

Confirm with **OK**. The **Dubbing** menu appears.

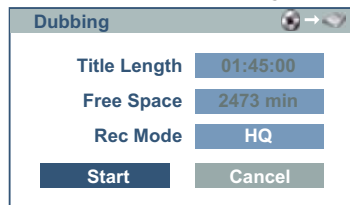

▲ ▼ ◀ ▶ Select **Rec Mode (HQ, SQ, LQ, EQ, Fast , AUTO)**.

▼ Select **Start** button.

OK start dubbing.



Cancel dubbing.

➡ Dubbing may not always be possible depending on the conditions of the recording device or the disc itself.

➡ When aborting the dubbing in **Auto** mode the recording is halted and all the data recorded up to this point are lost.

➡ The recording time in the **Auto** mode may be up to 19 minutes.

➡ The **Auto** mode is not available for edited titles on DVD-RW in the VR recording mode.

Dubbing

Overwrite recordings

+RW

Proceed as follows to overwrite a recorded title with a new video recording:

- ➡ This function is not possible for DVD+R because the recordings are always made at the end of the disc here.



Switch the recorder input to the signal source you wish to record from with the number buttons, the **P+** / **P-** buttons or the **0 AV** button.

MENU

Select Title List menu.

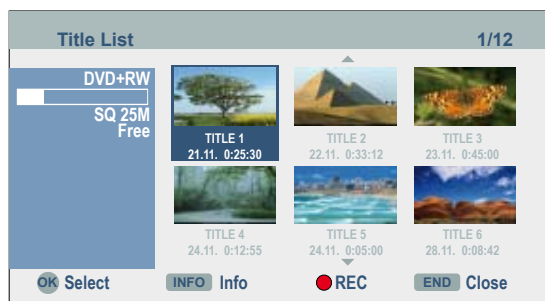

▲ ▼ ◀ ▶ Select title to be overwritten.

Start overwriting.



The overwriting begins at the start point of the selected title.



End recording. The new title is created and the updated menu is displayed.

- ➡ This function is not possible for protected titles (page 53).
- ➡ If the overwriting title is longer than the recorded title, the following title is overwritten. However, if the following title is protected, the recording stops at the start point of this title.
- ➡ If the length of the selected title is shorter than 10 seconds, the following title is overwritten. However, if this title is protected, recording stops.

Title List menus on other devices

+RW +R

The **Title List** menu can be displayed on DVD players on which DVD+RW or DVD+R discs can be played.

Insert a written DVD+R or DVD+RW disc.

Select the Title menu (see user guide of the respective unit).



Playing on other devices

Finalised discs, finalised DVD+R or DVD+RW discs recorded in video mode can be played on most DVD players. Some players can play finalised/unfinalised DVD-RW discs recorded in VR mode. Look in the player user guide to find out which disc formats it supports. In the finalisation the recordings are "fixed" so that the disc can be played on normal DVD players or computers with a DVD-ROM drive. In the finalisation of a disc in video mode, a menu is created for controlling the disc. Access is obtained with the **MENU** or **TITLE** buttons. For finalisation of a disc, please read "Finalisation" on page 26.

- ➡ Unfinalised DVD+RW discs can be played on normal DVD players.
- ➡ Edited contents of a DVD+RW disc can only be played on normal DVD players after finalisation.
- ➡ Edited contents of a DVD+R disc (hidden files, combined chapters, added chapter markers etc.) cannot be played on normal DVD players.

Troubleshooting

Problem	Possible cause	Remedy
No function.	The mains cable is not plugged in.	Fix the mains cable firmly into a socket.
No image.	The television is not switched to receive signals from the Recorder.	Select the right video input mode on the television, so that the image from the Recorder appears on the television screen.
	The SCART cable is not properly connected.	Connect the SCART cable properly.
	The television that is connected is switched off.	Switch the television on.
No sound.	The connected audio equipment is not switched to DVD playback.	Set the audio receiver so that you can hear the sound playing on your Recorder.
	The audio cables are not properly connected.	Connect the audio cable properly.
	The connected audio equipment is switched off.	Switch on the audio equipment that is connected.
	The audio connection cable is faulty.	Change it.
Inferior picture quality.	The disc is dirty.	Clean the disc.
Playback not possible.	There is no disc.	Insert a disc. (Check that the disc display comes on in the display window.)
	A non-playable disc has been inserted.	Insert a playable disc. (Check the disc type, the colour system and the region code.)
	The disc has not been inserted with the playable side downwards.	Insert the disc with the playable side downwards.
	The disc has not been properly placed in the guide.	Position the disc properly into the guide in the disc drawer.
	The disc is dirty.	Clean the disc.
	A security rating has been set.	Cancel the security rating or change the protection.
There is interference with images from an external source.	The video signal from the external component is copy-protected.	You cannot get a connection from this recorder. Connect the component directly into the television.
A channel is skipped when using P+ / P- .	The channels have not been saved in the recorder.	Retune the channels. See channel tuning on page 18.
The image or sound on the transmission channel is weak or absent.	Loose antenna or cable.	Tighten the connections or change the cable.
The camcorder image is not displaying.	The camcorder is switched off.	Switch on the camcorder and make sure you are using it properly.
The camcorder image is not appearing on the television screen when using the AV input or DV IN to the Recorder.	The Recorder AV selection is wrong.	Select the input channel (AV1, AV2, DV etc.) with DVD-AV.
A disc that was recorded to from this Recorder cannot be played on a different DVD player.	The disc was recorded in video mode.	Finalising the disc (page 26).

Troubleshooting

Problem	Possible cause	Remedy
A disc that was recorded to from this Recorder cannot be played on a different DVD player.	Some players do not play discs with finalisation in video mode.	No solution.
	The disc was recorded in VR mode.	The other player must be RW-compatible.
	The ability of CD-R / RWs (MP3/WMA, JPEG, (X)VCD, (X)SVCD) and DVD+R / RWs and DVD-R / RWs is influenced by the recording equipment, recording methods and data media. Therefore, there may be problems occasionally when playing on conventional DVD players.	No solution.
Playback not possible or unsuccessful.	There is insufficient space on the disc.	Use a different disc.
	The source that you want to record is copy-protected.	You cannot record the source.
	Copy-protected broadcasts cannot be recorded on a video mode disc.	Use a disc formatted in the VR mode for once copiable material.
Timer recording not possible.	The time has not been set correctly on the recorder.	Set the correct time. See "Setting the time automatically" or "Setting the time manually" on page 20.
	The timer was wrongly programmed.	Re-program the timer. See "Timer recording" on page 43.
	The time between programming the timer and the start of recording is too short.	The recording's start time must be at least 3 minutes into the future.
	After programming, the timer recording LED is no longer displayed.	Re-program the timer.
Stereo-audio recording and/or playback unavailable.	The television is not stereo-compatible or the broadcast transmission is not in stereo format.	No solution.
	The Recorder's A/V Out sockets are not connected to the TV's A/V In sockets.	Make the A/V connections.
	The Recorder's audio/video Out has not been selected for the television.	Select the AUX or A/V source as the TV input.
	The DVD recorder's TV audio channel must be set to Mono.	Set the TV's audio channel to stereo.
The remote control is not working properly.	The remote control's batteries have run out.	Replace the old batteries with new ones.
Interference is visible at the top and bottom edges of the screen.	Unfavourable resolution setting in HDMI mode.	Set the resolution to 1080i with the RES button (page 29).

Technical Specifications

General

ViewVision DR+	Item No. 66502
ViewVision DR+ Secam	Item No. 66532
Power supply	AC 110-240V, 50/60 Hz
Power consumption	During operation: 35 W In standby mode: <1 W (with energy save function)
Dimensions (approx.)	430 x 75 x 345 mm (W x H x D)
Weight (approx.)	4,1 kg
Operating temperature	5 °C to 35 °C
Humidity	5 % to 90 %
TV system	ViewVision DR+ PAL B/G, I, Secam DK ViewVision DR+ PAL B/G, Secam L PAL
Recording format	

Recording

Recording format	DVD Video-Recording, DVD-VIDEO
Rewritable memory media	Hard disk (HDD) 160 GB, DVD-RW, DVD-R, DVD+RW, DVD+R

Video recording format

Sampling frequency	27MHz
Compression format	MPEG 2

Audio recording format

Sampling frequency	48kHz
Compression format	Dolby Digital

Playback

Frequency response	DVD (PCM 48 kHz): 8 Hz to 22kHz, CD: 8 Hz to 20 kHz DVD (PCM 96 kHz): 8 Hz to 44 kHz
Signal-to-noise ratio	> 100 dB (AUDIO OUT connection)
Harmonic distortion	< 0,008% (AUDIO OUT connection)
Dynamic range	> 95 dB (AUDIO OUT connection)

Inputs

AERIAL IN	Aerial input, 75 ohms
VIDEO IN	1.0 Vp-p 75 ohms, negative sync. , RCA socket x 2 / SCART x 2
S-VIDEO IN	(Y) 1,0 V (p-p), 75 Ohm , negative Sync., Mini DIN 4-pin x 1 (C) 0,3 V (p-p) 75 Ohm
AUDIO IN	0 dBm > 47 kOhm, RCA socket (L, R) x 2 / SCART x 2
DV IN	4 Pins (i.LINK/IEEE 1394-Standard/DV-25)
Cardreader	7 in 2: SD, MMC, Memorystick (Pro), CF, MD, xD

Outputs

HDMI OUT	Type A, 19 Pin, LVDS digital, V1.2a
VIDEO OUT	1.0 Vp-p 75 ohms, negative Sync., RCA socket x 1 / SCART
S-VIDEO OUT	(Y) 1,0 V (p-p), 75 ohms , negative Sync., (C) 0,3 V (p-p) 75 ohms, Mini DIN 4-pin x 1 (Y) 1,0 V (p-p), 75 ohms, negative Sync., RCA socket x 1 (Pb)/(Pr) 0,7 V (p-p), 75 ohms, RCA socket x 3
COMPONENT VIDEO OUT	0,5 V (p-p), 75 ohms, RCA socket x 1 Optical connector x 1 (TOS-Link)
Audio output (digital audio)	2,0 Vrms (1 kHz, 0 dB), 600 ohms, RCA socket (L, R) x 1 / SCART
Audio output (optical audio)	
Audio output (analogue audio)	

Masthead

The Loewe Opta GmbH is a share company of German law with its Head Office in Kronach.

Industriestraße 11, 96317 Kronach
Telephone: + 49 (0)9261 / 99-0
Fax: + 49 (0)9261 / 99-500
E-mail: ccc@loewe.de

















Trade Register: Municipal Court Coburg, No. HRB 42243
VAT ID-No.: DE 193216550
WEEE registration no.: DE 41359413

Issue 10.07 5th edition
© Loewe Opta GmbH, Kronach
All rights reserved including translation.
Design and technical specifications are subject to change without notice.

Operating additional devices

Setting the remote control

The different Loewe sets can be set as follows on the Assist remote control:

Device	Button combination	
Loewe TV (Q2500 – L2650)	 + 	*
Loewe TV (Q2300 – Q2400)	 + 	
Loewe Centros 11x2	 + 	
Loewe Viewvision, Centros 21x2	 + 	
Loewe ViewVision DR+ (DVB-T)	 + 	*
Loewe ViewVision 8106 H	 + 	
Loewe Auro 2216 PS/8116 DT	 + 	*
Loewe Xemix 6222 PS	 + 	

* Factory setting

The specified key combination must be pressed (approx. 5 s) until one of the LEDs flashes twice.

Operating Loewe equipment

Using the remote control for a DVD player

 Press the **DVD** button, the indicator above it lights for about 5 seconds.

Using the remote control for a recorder

 Press the **REC** button, the indicator above it lights for about 5 seconds.

Using the remote control for a TV set

 Press the **TV** button, the indicator above it lights for about 5 seconds.

Every time you press the button, the indicator of the selected operating mode (TV – REC – DVD – RADIO) lights up.

Remote control Assist – TV-operation

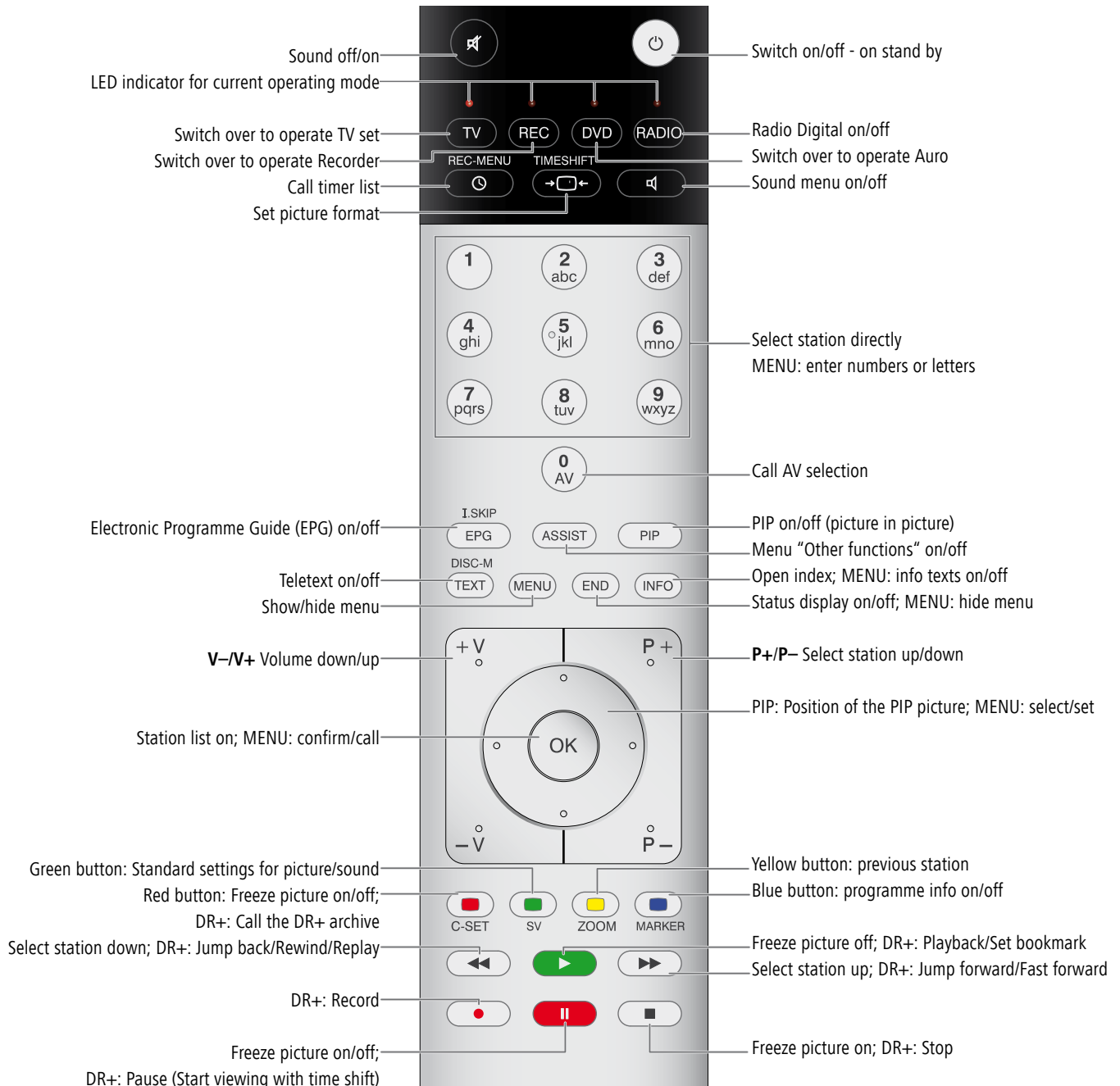

Language Code List

Enter the appropriate code when first setting up “Disc Audio”, “Disc Subtitles” and/or “Disc Menu”. (Further information can be found under “Disc Languages” on page 21.)

Code	Language	Code	Language	Code	Language
6565	Afar	7387	Hebrew	8379	Somali
6566	Abkhaz	7465	Japanese	8381	Albanian
6570	Afrikaans	7473	Yiddish	8382	Serbian
6577	Amharic	7487	Javanese	8385	Sudanese
6582	Arabic	7565	Georgian	8386	Swedish
6583	Assamese	7575	Kazakh	8387	Swahili
6588	Aymara	7576	Greenlandic	8465	Tamil
6590	Azerbaijani	7577	Cambodian	8469	Telugu
6665	Bashkir	7578	Canadian	8471	Tadzhik
6669	Byelorussian	7579	Korean	8472	Thai
6671	Bulgarian	7583	Kashmiri	8473	Tigrinya
6672	Bihari	7585	Kurdish	8475	Turkmen
6678	Bengali; Bangla	7589	Kirgiz	8476	Tagalog
6679	Tibetan	7665	Latin	8479	Tongan
6682	Breton	7678	Lingala	8482	Turkish
6765	Catalan	7679	Laotian	8484	Tatar
6779	Corsican	7684	Lithuanian	8487	Twi
6783	Czech	7686	Latvian	8575	Ukrainian
6789	Welsh	7771	Malagasy	8582	Urdu
6865	Danish	7773	Maori	8590	Uzbek
6869	German	7775	Macedonian	8673	Vietnamese
6890	Bhutanese	7776	Malayalam	8679	Volapuk
6976	Greek	7778	Mongolian	8779	Wolof
6978	English	7779	Moldovian	8872	Xhosa
6979	Esperanto	7782	Marathi	8979	Yoruba
6983	Spanish	7783	Malay	9072	Chinese
6984	Estonian	7784	Maltese	9085	Zulu
6985	Basque	7789	Burmese		
7065	Persian	7865	Nauruan		
7073	Finnish	7869	Nepalese		
7074	Fijian	7876	Dutch		
7079	Faroese	7879	Norwegian		
7082	French	7982	Oriya		
7089	Frisian	8065	Punjabi		
7165	Irish	8076	Polish		
7168	Scottish Gaelic	8083	Pashto		
7176	Galician	8084	Portuguese		
7178	Guarani	8185	Quechua		
7185	Gujarati	8277	Romansh		
7265	Hausa	8279	Romanian		
7273	Hindi	8285	Russian		
7282	Croatian	8365	Sanskrit		
7285	Hungarian	8368	Sindhi		
7289	Armenian	8372	Serbocroat		
7365	Interlingua	8373	Singhalese		
7378	Indonesian	8375	Slovak		
7383	Icelandic	8376	Slovene		
7384	Italian	8377	Samoa		
		8378	Shona		

List of country codes

Key in the corresponding code when first setting the “Area code” (page 24).

Code	Country code	Code	Country code	Code	Country code	Code	Country code
AD	Andorra	CV	Cape Verde	HU	Hungary	MS	Montserrat
AE	United Arab Emirates	CX	Christmas Islands	ID	Indonesia	MT	Malta
AF	Afghanistan	CY	Cyprus	IE	Ireland	MU	Mauritius
AG	Antigua and Barbuda	CZ	Czech Republic	IL	Israel	MV	Maldives
AI	Anguilla	DE	Germany	IN	India	MW	Malawi
AL	Albania	DJ	Djibouti	IO	British Territory in the Indian Ocean	MX	Mexico
AM	Armenia	DK	Denmark			MY	Malaysia
AN	Dutch Antilles	DM	Dominica	IQ	Iraq	MZ	Mozambique
AO	Angola	DO	Dominican Republic	IR	Iran	NA	Namibia
AQ	Antarctic	DZ	Algeria	IS	Iceland	NC	New Caledonia (French)
AR	Argentina	EC	Ecuador	IT	Italy	NE	Niger
AS	American Samoa	EE	Estonia	JM	Jamaica	NF	Norfolk Island
AT	Austria	EG	Egypt	JO	Jordan	NG	Nigeria
AU	Australia	EH	West Sahara	JP	Japan	NI	Nicaragua
AW	Aruba	ER	Eritrea	KE	Kenya	NL	Netherlands
AZ	Azerbaijan	ES	Spain	KG	Kirghizia	NO	Norway
BA	Bosnia-Herzegovina	ET	Ethiopia	KH	Cambodia	NP	Nepal
BB	Barbados	FI	Finland	KI	Kiribati	NR	Nauru
BD	Bangladesh	FJ	Fiji	KM	Comoros	NU	Niue
BE	Belgium	FK	Falkland Islands	KN	Saint Kitts and Nevis Anguilla	NZ	New Zealand
BF	Burkina Faso	FM	Micronesia	KP	North Korea	OM	Oman
BG	Bulgaria	FO	Faroe Islands	KR	South Korea	PA	Panama
BH	Bahrain	FR	France	KW	Kuwait	PE	Peru
BI	Burundi	FX	France (European Territory)	KY	Cayman Islands	PF	Polynesia (French)
BJ	Benin			KZ	Kazakhstan	PG	Papua New Guinea
BM	Bermuda	GA	Gabon	LA	Laos	PH	Philippines
BN	Brunei Darussalam	GB	Great Britain	LB	Lebanon	PK	Pakistan
BO	Bolivia	GD	Grenada	LC	Saint Lucia	PL	Poland
BR	Brazil	GE	Georgia	LI	Liechtenstein	PM	Saint Pierre and Miquelon
BS	Bahamas	GF	French Guyana	LK	Sri Lanka	PN	Pitcairn Island
BT	Bhutan	GH	Ghana	LR	Liberia	PR	Puerto Rico
BV	Bouvet Island	GI	Gibraltar	LS	Lesotho	PT	Portugal
BW	Botswana	GL	Greenland	LT	Lithuania	PW	Palau
BY	Byelorussia	GM	Gambia	LU	Luxembourg	PY	Paraguay
BZ	Belize	GN	Guinea	LV	Latvia	QA	Qatar
CA	Canada	GP	Guadeloupe (French)	LY	Libya	RE	Reunion (French)
CC	Cocos (Keeling) Islands	GQ	Equatorial Guinea	MA	Morocco	RO	Rumania
CF	Central African Republic	GR	Greece	MC	Monacco	RU	Russian Federation
CG	Congo	GS	S. Georgia & S. Sandwich Islands	MD	Moldova	RW	Rwanda
CH	Switzerland	GT	Guatemala	MG	Madagascar	SA	Saudi Arabia
CI	Ivory Coast	GU	Guam (USA)	MH	Marshall Islands		
CK	Cook Islands	GW	Guinea Bissau	MK	Macedonia		
CL	Chile	GY	Guyana	ML	Mali		
CM	Cameroon	HK	Hong Kong	MM	Myanmar		
CN	China	HM	Heard and McDonald Islands	MN	Mongolia		
CO	Columbia			MO	Macao		
CR	Costa Rica	HN	Honduras	MP	Northern Mariana Islands		
CS	Former Czechoslovakia	HR	Croatia	MQ	Martinique (French)		
CU	Cuba	HT	Haiti	MR	Mauretania		

Glossary

A

AV socket: Audio and video signal.

AV sources: Audio/video source.

AVS: Audio/video front sockets on the TV set (cinch and Mini-DIN).

C

Cinch cable: Cable for transmitting sound or picture.

Component Signal: The Component video signal consists of the "Y" brightness signal and the colour difference signals red and blue "U" and "V". Therefore it is sometimes called YUV signal. If the signal is transmitted in progressive scan, the signals are called YcrCb. For transmission in half screen mode (line jump method or interlace), the signals are called YPrPb.

D

Digital Link: System for controlling recorders (for Loewe video recorders and DVD recorders) via the Euro AV sockets of the Loewe TV set when installed in a concealed place. Control of the recorder for timer recordings.

Digital Link Plus: System for controlling recorders according to protocol 50. Station and timer data are transmitted to the recorder via the Euro AV socket for analog stations. The time recording is made exclusively by the recorder. Different names at different manufacturers.

DTS: Digital multi-channel sound.

Dolby Digital: Digital multi-channel sound.

Dolby Pro Logic: Analog multi-channel sound.

Dolby Surround: is an analog multi-channel sound system which accommodates four audio channels in two sound tracks using a matrix coding.

Dolby Virtual: Dolby Pro Logic audio signals are played over two speakers as a virtual surround signal.

DVD: abbreviation for Digital Video Disc and later Digital Versatile Disc.

DVD-Preceiver: combi-device of DVD player and radio.

DVI: Digital Visual Interface is an interface for transmitting digital video and graphic data (without sound).

E

Euro AV socket: Interface for connecting video recorders to a TV set. This socket is also known as a Scart socket.

H

HDCP: Copy protection standard.

HDMI: High Definition Multimedia Interface is a newly developed interface for full digital transmission of audio and video data.

L

LCD: Liquid Crystal Display.

L-Link: Interface for detection and control of Loewe audio components.

M

MPEG: Digital compression method for video.

Modulator: Transmitter in the recorder to receive signals via the TV tuner.

Mono: single channel sound.

N

NICAM: Sound standard NICAM is used in Belgium, Denmark, England, France, Sweden and Spain.

NTSC: American color standard.

P

PAL: European colour standard.

PCM: Puls Code Modulation for digital sound.

PIP: Picture in Picture, a function which shows two pictures on one screen.

Progressive Scan: Progressive Scan (PS for short) is a technique in the picture build-up of monitors, TV sets, beamers and other display devices in which the output device is not sent line interlaced half pictures – unlike in the interlace technique – but real full pictures.

Picture In Picture: see PIP.

R

RGB: colour signals red, green, blue.

S

Switching voltage: Video devices transmit this voltage to switch the TV to play.

SECAM: French colour standard.

SetTop-Box: Set-Top-Box refers to a device in entertainment electronics which is connected to another device, usually a TV set and offers the user additional useful features.

Signal strength: strength of the reception signal.

Signal quality: quality of the incoming signal.

Stereo: dual channel sound.

T

Terrestrial: In data transmission, a radio transmission which does not use a satellite as an intermediate station is called terrestrial.

Tuner: receiver

V

VPS: The Video Program System (VPS) is a signal which some (but not all) stations transmit in the scanning gap of the TV signal. The signal serves for video or DVD recorders to react to differences in the starting time, postponements and overrunning of the planned transmission time when recording programs.

Y

Ycc/Ypp: colour standard in Set-Top-Boxes.

Index

A

AERIAL 5
Area Code 24
AUDIO IN 5
AUDIO OUT 5
Auto Chapter 25
Automatic programming 17

B

Basic Settings 15

C

Card-Reader 39
Chapter List 46
Chapter marker 3
Clock set 20
Codelist RC3H 67–70
COMPONENT VIDEO OUT 5

Connections 12
 Accessories 15
 Aerial 12
 Amplifier 14
 Camcorder 15
 Decoder 14
 General 12
 Satellite Receiver 13
 Set-top box 13
 Television 13

Copy/move files/folders 36
Copy protection system 10
Copyright 10
CPRM 10

D

Delete Station 19
Digital Link 7, 15
Digital Link Plus 7, 17
DIGITAL OUT 5
Digital Video 44
Disc-related Terms 11
Disc Format 26
Disc Label 27
Disc Protect 27
Display 5
Disposal 7
DivX registration code 24
Dolby Digital 22
DTS 22

Dubbing 54
 Dub from DVD to HDD 55
 Dub from HDD to DVD 55
DV IN 4

E

Edit recordings 46
 Add chapter markers 47
 Combine chapters 52
 Combine titles 51
 Create new Playlist 47
 Delete part 49
 Divide title 52
 Edit thumbnail 47
 Move Playlists Chapters 53
 Protect title 53
 Sorting 51
 Title Name 50

Energy saving mode 21
EURO AV 1 5
EURO AV 2 5

F

Fernbedienung 61
Finalisation 26
Front Panel 4

G

Glossary 65

H

Hard disk 7
HDMI 5, 29

I

Initialisation 21
Inserting/removing memory
 cards 39

L

Language Code List 62
List of country codes 63

M

Main menu 16
Mains cable 5
Masthead 59
Memory capacity 39
Moving stations 19
MPEG 22

N

NICAM 20

O

Operating additional devices
 60

OPTICAL 5

P

Photo mode 38
Picture in Picture (PIP) 33
Play-Back Control 27
Playable Discs 10
Playback
 Audio CD 35
 Compatibility 36
 MP3/WMA media 35
 Program list 37
 Random play 36
Playback 30
 3D-Surround 32
 Camera positions 32
 CHAPTER 30
 Disc menu 32
 DivX files 34
 Freeze frame 31
 Markers 31
 Media with mixed contents
 33

 Repeat 31
 Search 30
 Skip 30
 Slow Motion 31
 Subtitles 33
 Time 31
 TITLE 30
 Title menu 32
 Zoom 31
Playing on other devices 56
Playlist 47
Program Edit 18
Progressive Scan 12

R

Rating 23
Rear Panel 5
Recording 41
 Clip recording 41
 Delayed TV viewing 41
 Digital Video 44
 Manual Record 42
 Record from external
 sources 44
 ShowView 43
 Simultaneous record and
 display 42
 Timer Recording 43
 Timer Record List 44
 Timeshift mode 41
Regional code 11
Remote Control 12, 40, 61
Remote control 3
Resetting 12
Rewritable discs 9

S

S-VIDEO OUT 5
Safety 8
Scope of delivery 6
Screen Menus 28
Service 64
Set Password 22
 Delete 23
 Switching off 23
Set up 6
Setup menu 16
 Audio Menu 22
 Disc Menu 26
 General Menu 17
 Language Menu 21
 Lock Menu 22
 Recording Menu 25
Slide Show 38
Station Rename 19
Symbols 11

T

Technical Specifications 59
Technische Daten 59
Title List 46
Trademark rights 6
Troubleshooting 57–58

V

VIDEO IN 5
VIDEO OUT 5
VIDEO OUTPUT switch 5

Service

(A)

Loewe Austria GmbH
Parking 10
1010 Wien, Österreich
Tel.: +43 - 810/0810-24 (zum Ortstarif)
E-Mail loewe@loewe.co.at

(AUS)

International Dynamics
Australasia Pty Ltd.
129 Palmer Street
Richmond 3121, Victoria, Australia
Tel. +61 - 3 - 94 29 08 22
Fax +61 - 3 - 94 29 08 33
Email mail@internationaldynamics.com.au

(B) (NL) (L)

Loewe Opta Benelux NV/SA
Uilenbaan 84
2160 Antwerpen, België
Tel. +32 - 3 - 2 70 99 30
Fax +32 - 3 - 2 71 01 08
Email ccc@loewe.be

(CH)

Telion AG
Rütistrasse 26
8952 Schlieren, Schweiz
Tel. +41 - 44 732 15 11
Fax +41 - 44 732 15 02
Email infocpe@telion.ch

(CY)

HADJIKYRIAKOS & SONS LTD.
Prodrromou 121, P.O. Box 21587
1511 Nicosia, Cyprus
Tel. +357 - 22 87 21 11
Fax +357 - 22 66 33 91
Email Efthymios@hadjikyriakos.com.cy

(CZ)

Ing. Ivo Tietz
Dolní nám. 9
746 01 Opava, Česko
Tel. +420 553 624 944
Fax +420 553 623 147
Email tietz@opava.cz

(D)

Loewe Opta GmbH,
Customer Care Center
Industriestraße 11
96317 Kronach, Deutschland
Tel. +49 1801-22256393
Fax +49 9261-99500
Email ccc@loewe.de

(DK)

Kjaerulff 1 A/S
C.F. Tietgens Boulevard 19
5220 Odense SØ, Denmark
Tel. +45 - 66 13 54 80
Fax +45 - 66 13 54 10
Email mail@kjaerulff1.com

(E)

Gaplasa S.A.
Conde de Torroja, 25
28022 Madrid, España
Tel. +34 - 917 48 29 60
Fax +34 - 913 29 16 75
Email loewe@maygap.com

(F)

Loewe Opta France S.A.
13 rue du Dépôt,
Parc del l'Europe, BP 10010
67014 Strasbourg Cédex, France
Tel. +33 - 3 - 88 79 72 50
Fax +33 - 3 - 88 79 72 59
Email loewe.france@wanadoo.fr

(FIN)

Kjaerulff 1 OY
Uudenmaantie 100
20760 Piispanristi, Finland
Tel. +358 - 20 751 3800
Fax +358 - 20 751 3801
Email Finland@kjaerulff1.com

(GB)

Loewe UK Limited
Century Court, Riverside Way
Riverside Business Park, Irvine, Ayrshire
KA11 5DD, UK
Tel. +44 - 1294 315 000
Fax +44 - 1294 315 001
Email enquiries@loewe-uk.com

(GR)

SIBA Engineering S.A.
6, Kifissou Av.,
122 42 Aegaleo, Hellas
Tel. +30 - 210 - 5913793
Fax +30 - 210 - 5317755
Email service@siba.gr

(H)

Basys Magyarorszag KFT
Epitok utja 2-4
2040 Budaörs, Magyar
Tel. +36 - 23 41 56 37 (121)
Fax +36 - 23 41 51 82
Email basys@mail.basys.hu

(I)

Loewe Italiana SRL
Largo del Perlar, 12
37135 Verona (VR), Italia
Tel. +39 - 045 82 51 619
Fax +39 - 045 82 51 622
Email Angelo.Lorenzi@loewe.it

(IL)

PL Trading (pz 2004) Ltd.
27, Aliat Hanoar St.
Givataiim 53401, Israel
Tel. +972 - 3 - 57 27 155
Fax +972 - 3 - 57 27 150
Email info@loewe.co.il

(M)

Mirage Holdings Ltd
Flamingo Complex, Cannon Road
Qormi, Malta
Tel. +356 - 22 - 79 40 00
Fax +356 - 21 - 44 59 83
Email servicing@mirage.com.mt

(MA)

SOMARA S.A.
377, Rue Mustapha El Maani
20000 Casablanca, Morocco
Tel. +212 - 22 22 03 08
Fax +212 - 22 26 00 06
Email somara@wanadooopro.ma

(N)

CableCom AS
Gneisveien 12
3221 Sandefjord, Norge
Tel. +47 - 33 48 33 48
Fax +47 - 33 44 60 44
Email soren@cablecom.no

(NZ)

International Dynamics (NZ) Pty Ltd
PO Box 109 317, Newmarket
Auckland, New Zealand
Tel. +64 9 379 0179
Fax +64 9 379 0279
Email: enquiries@internationaldynamics.co.nz

(P)

Videoacústica
Comercio e Representacoes de
Equipamentos Electronicos S.A.
Estrada Circunvalacao,
Quinta do Paizinho, Arm. 5
2795-632 Carnaxide, Portugal
Tel. +351 - 2 14 24 17 70
Fax +351 - 2 14 18 80 93
Email office@videoacustica.pt

(PL)

DSV TRADING SA
Plac Kaszubski 8
81-350 Gdynia, Polska
Tel. +48 - 58 - 6 61 28 00
Fax +48 - 58 - 6 61 44 70
Email market@dsv.com.pl

(RUS)

Service Center Loewe
ul. Verkhnyaya Maslovka, d. 29
125083 Moscow, Россия
Tel. +7 - 495 612 50 43
Fax +7 - 495 612 47 10
Email service@atc.ru

(S)

Kjaerulff 1 AB
Ridbanegatan 4, Box 9076
21377 Malmö, Sverige
Tel. +46 - 4 06 79 74 00
Fax +46 - 4 06 79 74 01
Email Sweden@kjaerulff1.com

(SK)

BaSys Czech & Slovak s.r.o.
Stará Vajnorská 17/A
831 04 Bratislava, Slovakia
Tel. +421 2 49 10 66 18
Fax +421 2 49 10 66 33
Email: loewe@basys.sk

(SLO)

Jadran Trgovsko Podjetje
Partizanska cesta 69
6210 Sezana, Slovenija
Tel. +386 - 57 31 04 40
Fax +386 - 57 31 04 42
Email milos.zvanut@jadran.si

(TR)

Enkay Elektronik Servis Müdürlüğü
Alemdag Cad: Site Yolu No.: 10
Ümraniye/ İstanbul, Türkiye
Tel. +90 - 216 634 44 44
Fax +90 - 216 634 39 88
Email mhatipog@enkaygroup.com

(ZA)

Videonix (Pty) Ltd
P.O. Box 31952, Kyalami 1684
Republic of South Africa
Tel. +27 - 1 14 66 47 00
Fax +27 - 1 14 66 42 85
Email mail@loewe.co.za