

---

# Reference

TV

Reference ID 55

Reference ID 46

Reference ID 40



User guide

---

**LOEWE.**

35319021





## Imprint

Loewe Opta GmbH  
Industriestraße 11  
D-96317 Kronach  
[www.loewe.de](http://www.loewe.de)

Printed in Germany  
Editorial date 03/13-2.0 TB/FP  
© Loewe Opta GmbH, Kronach  
ID: 1.10.6

All rights including translation, technical modifications and errors reserved.



<b>Imprint.....</b>	<b>2</b>	<b>Audio/Radio .....</b>	<b>64</b>
<b>Welcome.....</b>	<b>5</b>	Audio/Radio – MediaHome.....	64
Scope of delivery .....	5	Audio playback .....	66
About this user guide.....	5	Radio mode (DVB radio) .....	69
<b>For your safety.....</b>	<b>6</b>	Radio mode (Internet radio) .....	70
<b>Basic functions.....</b>	<b>8</b>	<b>Photo .....</b>	<b>71</b>
<b>Remote control.....</b>	<b>9</b>	Photo – MediaHome.....	71
<b>Operating controls on the TV set.....</b>	<b>10</b>	Photo display.....	72
<b>Connections rear side of the device .....</b>	<b>11</b>	<b>Web .....</b>	<b>74</b>
<b>Preparing the TV set.....</b>	<b>12</b>	MediaNet .....	74
Installing the TV set .....	12	Browser.....	76
Set covers.....	12	<b>Extras.....</b>	<b>77</b>
Connecting the TV set.....	12	Timer .....	77
Bundling the cables.....	13	Conditional Access module (CA module).....	81
Preparing the remote control unit.....	13	Special functions .....	83
Switching the TV set ON/OFF .....	14	AV selection.....	83
Technical information .....	14	DR+ Streaming.....	84
<b>General information on menu operation.....</b>	<b>15</b>	<b>System settings .....</b>	<b>85</b>
Info display.....	18	Picture .....	86
Operation without remote control.....	18	Sound.....	90
<b>LED backlighting.....</b>	<b>19</b>	Stations.....	91
<b>Initial installation.....</b>	<b>20</b>	Automatic scan TV+Radio.....	92
Initial installation wizard .....	20	Manual Scan TV / Radio.....	93
<b>Home view.....</b>	<b>32</b>	Station lists TV / Radio .....	95
Home - Favourites .....	33	Compose / edit Personal list.....	96
<b>TV.....</b>	<b>34</b>	Update station list automatically.....	97
Setting the volume .....	34	Control .....	98
Select station .....	34	Language .....	99
Status display.....	36	Picture in Picture (PIP).....	99
Function list .....	37	Parental lock .....	100
Electronic Programme Guide – EPG.....	38	Energy efficiency.....	101
Teletext.....	41	Software update.....	101
Rotate TV .....	42	On-screen displays.....	104
HbbTV / MediaText.....	43	Time and date .....	104
Picture in Picture (PIP).....	44	DVB settings.....	105
Digital Recorder .....	45	EPG .....	105
Digital-Recorder – Overview of functions .....	45	DR+ .....	106
TV viewing with time shift.....	46	Standard Teletext.....	107
Archive recording.....	47	HbbTV .....	108
DR+ archive .....	49	CA module(s).....	109
DR+ Streaming.....	53	LED light module.....	110
<b>Media+.....</b>	<b>54</b>	Rotate TV .....	111
General information on media reproduction.....	54	Record .....	112
Accessing your media.....	54	Hard disks .....	113
<b>Video.....</b>	<b>55</b>	Multimedia / Network.....	114
Video – MediaHome .....	55	Network settings.....	114
Video playback.....	56	Multimedia settings.....	117
		Connections.....	118
		Sound components .....	119
		Antenna DVB.....	123
		AV connection settings .....	123
		Digital Link.....	124
		Gaming mode .....	124
		Assign digital audio input.....	125

<b>External devices .....</b>	<b>126</b>
Devices to the HDMI connections.....	126
Devices on AV.....	127
Devices on AV.....	128
Connecting the Loewe speaker system.....	130
Connecting active loudspeakers.....	131
Connecting the HiFi/AV amplifier.....	131
Audio playback from external devices.....	132
Serial interface RS-232C (RJ12).....	132
Operating Loewe units.....	133
<b>Teaching the remote control .....</b>	<b>134</b>
<b>Loewe Apps.....</b>	<b>136</b>
<b>Troubleshooting .....</b>	<b>139</b>
<b>Technical Data.....</b>	<b>141</b>
Function of the connections .....	142
Media.....	143
Signals via AVS (PC IN) / HDMI.....	144
Signal input groups .....	144
<b>Accessories.....</b>	<b>145</b>
Upgrade kits / conversion kits / cables .....	145
Equipment variants.....	146
Integrated features.....	146
Mounting options .....	147
<b>Environment .....</b>	<b>148</b>
<b>Legal notes.....</b>	<b>148</b>
<b>Glossary .....</b>	<b>149</b>
<b>EC Declaration of Conformity.....</b>	<b>153</b>
<b>Index.....</b>	<b>155</b>
<b>Service.....</b>	<b>158</b>
<b>Code page .....</b>	<b>159</b>
<b>Notes .....</b>	<b>161</b>

---

## Thank you,

for choosing a Loewe TV set!

At Loewe we combine the highest requirements regarding technology, design and ease of use. This applies equally for TV, video and accessories.

In addition to sleek design and a varied combination of colour and mounting choices, your Loewe TV set offers a host of technological options.

### Loewe Image<sup>+</sup>

State-of-the-art full HD LCD displays with LED backlit TV technology guarantee the best image quality and high contrast values and all this at lowest possible energy consumption.

### Loewe Digital<sup>+</sup>

The integrated triple tuner for DVB-T/C/S enables the reception of standard as well as high-definition contents and thanks to the CI Plus interface even from Pay TV.

### Loewe Sound<sup>+</sup>

Audio competence on the highest level - this is for what Loewe is unique: an integrated multichannel decoder provides 5.1 Home Entertainment of outstanding quality without any external devices.

### Loewe DR<sup>+</sup>

Due to Loewe DR+, recording of TV transmissions on the integrated hard disk by simply pressing a key or halting the current transmission are no problem. Additionally, DR+ Streaming enables the retrieval of films on further Loewe devices.

### Loewe Assist<sup>+</sup>

The intuitive Loewe user interface Assist Media offers a simple access to all device functions; by means of the HOME key on the remote control you can access all your favourite content as well as all multimedia functions of your TV set.

### Loewe Media<sup>+</sup>

The Loewe Multimedia functions offer you a multitude of options: via MediaHome you have access to your photos, videos and music in your home network or on the USB stick.

Loewe MediaNet and MediaText help you to access numerous worldwide web-applications and contents from HbbTV services.

### Loewe Connectivity<sup>+</sup>

Network your TV set by means of numerous interconnection options. Be it HDMI, USB, CI Plus or LAN/WLAN, discover the world of the Loewe networking possibilities.

## Scope of delivery

- LCD TV set
- Mains cable
- Antenna cable
- Remote control Assist with two batteries
- Quick guide

## About this user guide

**i** For best results regarding safety and the longevity of the set, we recommend you read the chapter **For your safety** (see page 6) before switching it on for the first time.

The index/glossary starting from page 149 gives explanations of certain terms used in the TV set and the user guide.

Paragraphs which begin with the symbol **i** indicate important instructions, tips or conditions for the following settings.

Terms which you will find in the menus or printed on the remote control or TV set are written in **bold** type.

The necessary control elements are shown in the descriptions to the left of the text containing the instructions for action.

In addition to the remote control, a PC keyboard can be connected to one of the USB ports on your TV and then used to control your TV set.



In the user guide, this symbol indicates places in which the use of a keyboard is particularly advantageous.

Depending on the connected accessory equipment the menus in the TV set can differ from those described here.

All the station names, programme contents, the illustrated photos, titles, albums and album covers in this user guide are examples.

The user guide for your TV set is updated at irregular intervals. We recommend checking now and then, especially after a software update.

## General information on menu operation of the TV set

For further information on the user interface and the general operation of your TV set see page 15.

## Interactive data services

In some countries the stations also broadcast interactive data services with their programmes, leading to the functions of individual buttons not being available or only so to a limited extent. You can find out more about this starting from page 43.

**For your safety, and to avoid unnecessary damage to your unit, please read and follow the safety advice below:**

### Use for the intended purpose and ambient conditions

This TV set is intended exclusively for rendering video and audio signals and is designed for use in residential apartments or office premises. It must not be used in rooms with a high level of **humidity** (e.g., bathroom, sauna) or a high **dust concentration** (e.g., workshops). The manufacturer's warranty is only valid for use in the specified permissible environment.

If the unit is used outdoors, make sure that it is protected from **moisture** (rain, dripping water and splashing water or dew). High humidity and dust concentrations lead to leakage currents in the device. This can result in a shock hazard by touching it or even fire.

If you have moved the unit out of the **cold** into a warm environment, leave it switched off for about an hour to avoid the formation of **condensation**.

Do not place **objects** containing **liquids** on top of the unit. Protect the appliance against dripping and splashing water.

**Candles** or **naked flames** must be kept away from the TV set at all times to prevent it from catching fire.

Never place the TV set in a location where it is exposed to **vibrations**. This can lead to material overload.

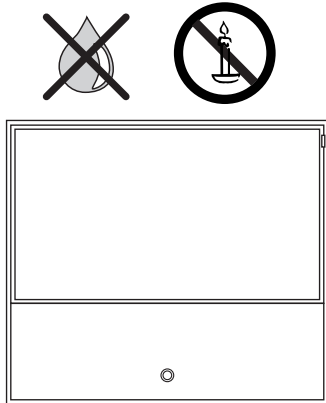

### Transporting

Move the device in **vertical position** only. Grasp the device on the upper and lower edges of the housing.

The set is delivered ex factory without a mounting option. If the set has to be put down during packing/unpacking, place the TV set with its entire front surface lying flat on soft material such as a blanket or the fleece from the packing material. Use a blanket or the fleece from the packing material as an underlay.

The LCD screen is made of glass or plastic and can break if not handled properly.

Always wear rubber gloves to carry the TV set if the LCD screen is damaged and **liquid** crystal might be leaking out. In the case of **skin contact** immediately rinse thoroughly with water.

### Power supply

**Incorrect voltages** can damage the unit. This device may only be connected to a power supply with the voltage and frequency indicated on the type plate using the supplied mains cable. The **mains plug** of the TV set must be easily accessible so that the device can be disconnected from the mains at any time. When unplugging the unit from the mains, pull at the connector body and not at the **cable**. The cables in the mains plug could otherwise be damaged and could cause a **short-circuit** when plugged in again.

Lay the **mains cable** so that it can not be damaged. The power cable may not be kinked or laid over sharp edges, stood on or exposed to **chemicals**; the latter also applies to the unit as a whole. A power cable with damaged insulation can cause **electric shocks** and poses a **fire risk**.

### Air circulation and high temperatures

The **vent slots** on the **rear panel of the set** must always be kept unobstructed. Please do not place newspapers or cloths on/over the TV set.

Ensure that there is at least 10 cm free space on the sides and above the set for air circulation, if the set is placed in a **cabinet** or on a **shelf**.

Like any electronic device, your TV set requires **air for cooling**. Obstruction of the air circulation can cause fires.

Prevent **metal items**, needles, paper clips, liquids, wax, or similar items, from getting

into the interior of the device through the **vent slots** in the rear panel. Such objects can cause **short circuits** in the set, which could possibly cause a fire.

If something should get into the **interior of the set** then immediately unplug the mains plug of the device and contact the **field service** for more information.

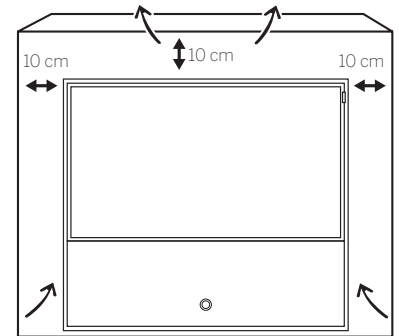

### Set-up

The set is suitable for mounting in many different ways. Note the assembly instructions regarding the different possible mounting options.

Before setting up the device, please check that the final location is suitable to bear the load of the device in terms of surface (sensitivity to pressure) and stability.

Place the TV set with the stand only on a **level, sturdy, horizontal base**. Particularly ensure that the set does not protrude to the front when placed in or on pieces of furniture.

Place the TV set in a normal position for use. TV set may only be used in an upright **horizontal** position. It may not be tilted by more than 10 degrees. The TV set must never be operated vertically, lying flat or hanging overhead from the ceiling.

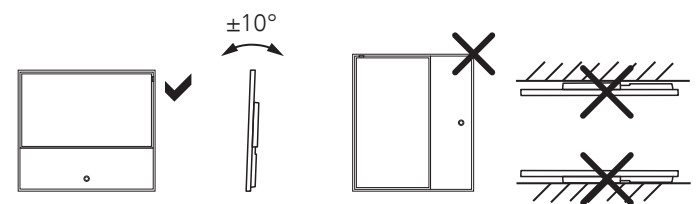

Set up the device where it is not exposed to direct **insolation** and where it is not exposed to additional heating by **radiators**.

### Note on the LCD screen

The TV set with LCD screen you have purchased satisfies the most rigorous quality requirements and has been inspected with respect to **pixel errors**. Despite of thorough care when manufacturing the display, it cannot be 100% guaranteed that no **subpixel** defects will occur due to technical reasons. Please understand that these types of effects, as long as they are within the standard of specified limits, cannot be considered as a device defect in terms of the guarantee.

Avoid displaying still images for long periods of time. It is possible that a copy of the image may remain.



## TV sets with 3D function

Read the following safety instructions before using the 3D function of your TV set.

Please use the Loewe 3D TV sets only with the Loewe 3D glasses which can be purchased as an accessory from your Loewe dealer (see Accessories on page 145).

People that have a visual disorder may not be able to perceive 3D effects or may only be able to perceive them to a limited extent. People that are sensitive to flickering images (e.g. those with epilepsy) should only use this product after having consulted their doctor.

It might take some time for you to get used to the 3D glasses and before you can perceive the 3D effects properly.

Stop using the 3D devices immediately if you experience any feelings of nausea, dizziness or malaise when viewing 3D content.

Supervise children whilst they are viewing 3D content, as they can be particularly sensitive to it.

Allow more time for a break when viewing 3D films, so that you are able to relax. Failure to do this could result in headaches, fatigue, dizziness or malaise.

Position yourself comfortably in front of the 3D TV set and ensure that you are seated firmly. By doing this, you will avoid any injuries that may arise due to reacting to extreme 3D content.

Switch off any artificial light sources (e.g. energy saving lamp) between the 3D TV set and the 3D glasses. These could impair the infrared reception or the TV picture may flicker as a result.

## Supervision

Do not let **children** loiter and play unsupervised close to the device. The set could tip over, be pushed off or pulled down from the stand surface and injure someone.

Do not allow the switched-on TV set to run **unattended**.

## Volume

Loud music can lead to ear damage. Avoid extreme volume especially over long periods and when using headphones.

## Thunder storms

Pull out the mains plug and all connected **antenna cables** from the TV set in a thunderstorm. Overvoltage caused by **lightning strokes** can damage the set via the antenna system, as well as via the mains. The mains plug and all connected antenna cables should also be pulled out during long periods of **absence**.

## Automatic shutdown

If the TV is not operated for 4 hours (adjustment of volume, programme change, etc.) the TV will automatically switch to stand-by mode to save energy. A prompt to terminate this shutdown process appears one minute before expiry of the 4 hours.

The automatic shutdown is generally active for the TV mode as soon as the energy efficiency mode **Home Mode** is enabled for at least one of the six signal input groups (see page 144). This also applies if another energy efficiency mode is selected when putting into operation for the first time (see page 20), but one of the six signal input groups is subsequently set to **Home Mode**.

Automatic shutdown does **not** occur when using the radio **without** screen display (**screen off**).

## Cleaning and care

**i** Switch off the TV set with the main switch prior to cleaning.

Clean the TV set, the screen, and the remote control unit with a soft, moist, clean and colour-neutral cloth only, **without** any **aggressive** or **scouring cleaning agents**.

For TV sets with textile **speaker grill**:

Vacuum the surface regularly with a soft brush attachment.

In case of **dirt** or **stains**:

Moisten a soft, colour-neutral cloth with detergent or normal stain remover and gently rub away the stain. You can also treat the mark/stain directly with normal dry stain remover spray (vacuum up powder).

Do not moisten the fabric cover directly with detergent or stain remover (risk of encrustation). Do not use any solvents to clean the fabric.

➤ Follow the manufacturer's instructions when using stain removers.

➤ There is an increased risk of encrustation when cleaning speaker grills having nicotine deposits.

## Repairs and accessories

Never remove the back of the TV set yourself. Have your TV set repaired or serviced by **authorised television technicians** only.

Only use **original accessories** such as Loewe stands, if possible (see Accessories on page 145).

## On/Off of the television set



Switching the TV set ON / switching it OFF in Standby mode (Mains switch must be switched ON)

When TV set is switched on:  
Press key long: Switch TV set and all CEC-capable devices connected to the **HDMI** interfaces OFF to Standby mode (System Standby).

## General navigation



◀ ▶ ◂ ▸ Navigation on the user interface, select objects

## Select station



**OK** short: Call station list. Or:  
**OK** long: Call expanded station list.

◂ ▸ ◃ ◅ Mark station,  
**OK** switch over to station.

Or:



**P+ / P-** Next/previous channel

Or:



Select station with numerical keys

## Sound



**V+ / V-** Increase/reduce volume



Sound on/off

## Key functions



TV operation



Call radio mode (standard assignment) <sup>1</sup>



Call **Home** view,  
Select the operating mode or the function



During screen fade-in function: Info display,  
info text appropriate to the content that can assist you further, should you have any questions about your TV device;

Without on-screen display: access status display.  
With status display open and repeatedly pressing the key call / close the detailed information on the broadcast



Open the DR+ archive



Add current object to **Home** favourites



Call MediaNet



On/Off EPG (Electronic Programme Guide)



On/Off PIP (picture in picture)



Turn Teletext/MediaText on/off



Call function list for the active operating mode



Pressing briefly: step / level back;  
Pressing long: close all displays

## Colour key function during TV operation



**Red key:** Start HbbTV or value-added network service

**Yellow key:** Last selected station

**Blue key:** Call function list  
(selection of language/sound,  
subtitles or channel/video track)

## Function of the coloured keys in audio mode



**Green key:** Switch screen ON/OFF

**Yellow key:** Last selected station in DVB radio mode

<sup>1</sup> The assignment of these keys can be changed (see page 133). The description refers to the standard setting.

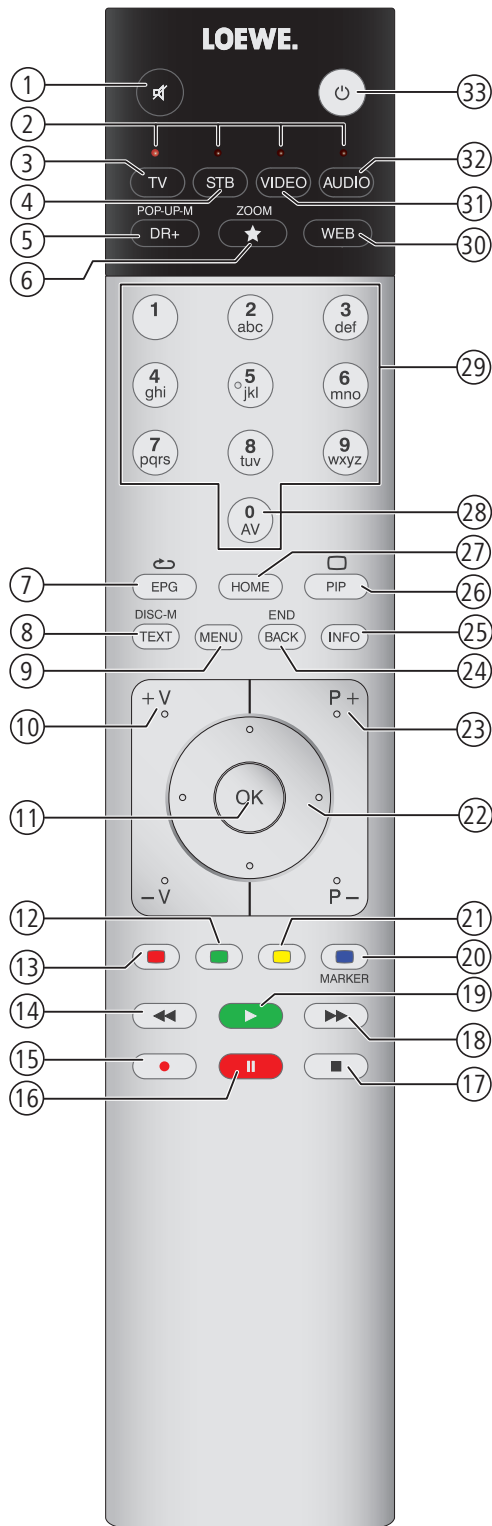

- ① Sound mute/on..... (page 34)
- ② LED display for currently operated device..... (page 133)
- ③ Switch to TV mode..... (page 13; 133)
- ④ Reassign remote control to SetTop-Box (**PACE DS440N**)<sup>1</sup>
- ⑤ DR+ archive on/off..... (page 49)
- ⑥ Define active object as favourite..... (page 33)
- ⑦ Electronic Programme Guide on/off..... (page 38)
- ⑧ Teletext/MediaText<sup>2</sup> on/off..... (page 41; 43)
- ⑨ Call function list..... (page 37)
- ⑩ **V+/-V-** Increase/reduce volume..... (page 34)
- ⑪ Call station list / expanded station list..... (page 34; 35)  
In the menu: confirm/call up..... (page 15)
- ⑫ Green coloured key: screen on/off..... (page 68)
- ⑬ Red coloured key: call preferred value-added network service<sup>2</sup>..... (page 43)
- ⑭ Jump / wind..... (page 58; 59)
- ⑮ Direct recording (One Touch Recording)..... (page 47)
- ⑯ Start / interrupt timeshift television..... (page 46)
- ⑰ Finish timeshift..... (page 46)
- ⑱ Jump / wind..... (page 58; 59)
- ⑲ Start / continue timeshift television..... (page 46)
- ⑳ Blue coloured key: call station function list with subfunctions..... (page 8)
- ㉑ Yellow coloured key: switching to previously received station..... (page 8)
- ㉒ In menu / in lists: selecting/setting..... (page 15)  
◀ ▶ with Motor Unit connected: Rotate TV set
- ㉓ **P+/-P-** Select stations up/down..... (page 34)
- ㉔ Press briefly: back to previous window (step back)..... (page 15)  
Press long: close all displays..... (page 15)
- ㉕ Status display on/off..... (page 36)  
In menu: context-relevant Info on/ off..... (page 18)
- ㉖ PIP (picture in picture) on/off..... (page 44)
- ㉗ Open/close **Home** view..... (page 32)
- ㉘ AV selection..... (page 83)
- ㉙ Select station directly..... (page 34)  
In the menu: Enter numbers or letters..... (page 17)
- ㉚ Call **MediaNet**..... (page 74)
- ㉛ Reassign remote control to **BluTech Vision 3D**<sup>1</sup>
- ㉜ Switch to radio mode<sup>1</sup>..... (page 69)
- ㉝ Switch ON/OFF to standby mode..... (page 14)  
System standby..... (page 14)

The key assignment displayed here is valid for the main level of the TV set. The key assignment may vary in certain operating modes (see the corresponding chapter in this user guide).

<sup>1</sup> The assignment of these keys can be changed (see page 133). The description refers to the standard setting.

<sup>2</sup> Depending on the corresponding settings (see page 108).

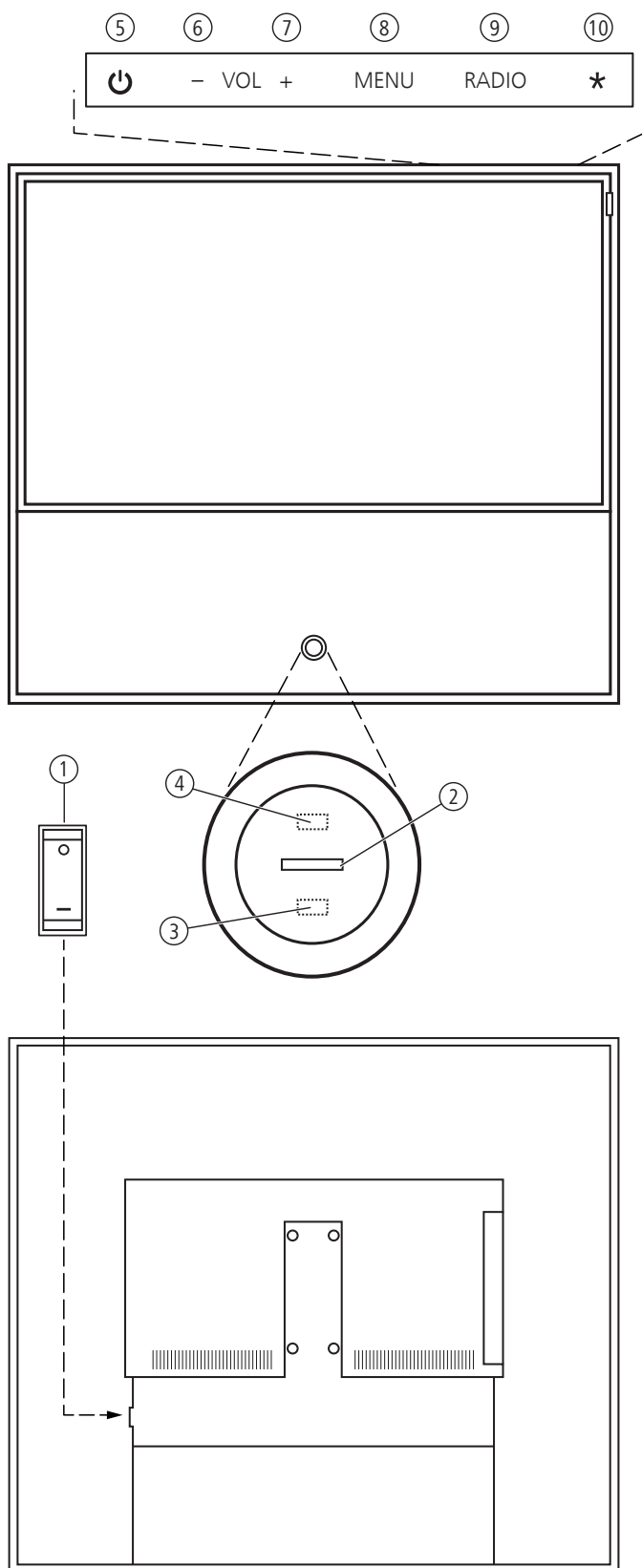

## Functions of the operating elements





### ① Mains switch:

The mains switch is located on the rear side of the set.

**Always** return the TV set to Standby mode before switching it off with the main switch.

■ The TV set will be completely separated from mains only when you unplug the mains cable.

### ② Display:

	white:	Standby
	white, intermittent:	TV set starts
	green:	TV set switched on
	red:	timer recording active
	blue:	TV set in standby, background operation active (EPG data updating, software update or DR+ streaming server function)

### ③ IR receiver:

Infrared receiver for receiving the remote control commands.

### ④ Infrared transmitter:

When showing 3D content, the 3D glasses **Loewe Active Glasses 3D** are controlled via the infrared sensor.

### ⑤ On/Off key:

Switching on in standby mode

Switching off to the standby mode

### ⑥ Key +:

increase volume

Direct control on TV set: to the right ▶

### ⑦ Key -:

reduce volume

Direct control on TV set: to the left ◀

### ⑧ Key MENU:

TV set in standby mode: switch TV set on in TV mode

TV set switched on: call direct control on TV set

Direct control on TV set: up ▲

### ⑨ Key RADIO:

TV set in standby mode: switch TV set on in radio mode

TV set switched on: toggle TV mode and radio mode

Direct control on TV set: down ▼

### ⑩ Key \*:

For TV sets **without** LED backlighting: No function.

For TV sets **with** LED backlighting: dimming / switching on/off of the LED backlighting.



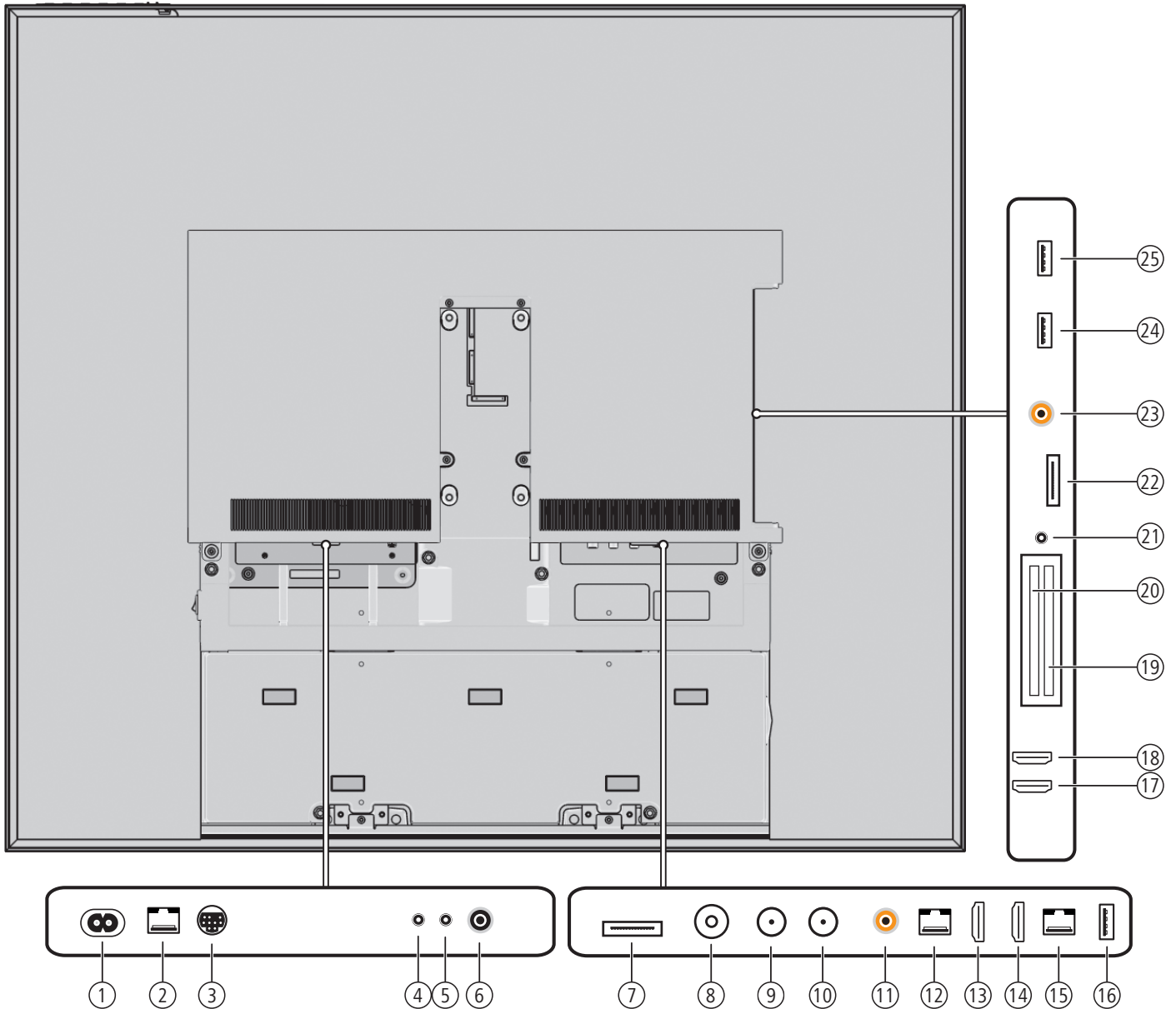

- ① **AC IN** - Mains connection
- ② **RS-232C** - Serial interface
- ③ **CONTROL** - Rotating stand control
- ④ **IR LINK** - Infrared transmitter connection
- ⑤ **AUDIO OUT** - Audio output (analogue)
- ⑥ **CENTER IN** - Centre audio input (analogue)
- ⑦ **AV** - Mini AV socket <sup>†</sup>
- ⑧ **ANT-TV** - Antenna/cable analogue/digital
- ⑨ **ANT SAT** - Satellite antenna (Sat tuner 1)
- ⑩ **ANT SAT 2** - Satellite antenna (Sat tuner 2)
- ⑪ **SPDIF OUT** - Digital audio output
- ⑫ **DIGITAL AUDIO LINK** - Surround audio outputs (digital)

- ⑬ **HDMI 1** - HDMI input 1
- ⑭ **HDMI 2** - HDMI input 2
- ⑮ **LAN** - Network connection
- ⑯ **USB** - USB connection
- ⑰ **HDMI 3** - HDMI input 3
- ⑱ **HDMI 4** - HDMI input 4
- ⑲ **CI COMMON INTERFACE** - Common interface 1 (CI slot 1)
- ⑳ **CI COMMON INTERFACE** - Common interface 2 (CI slot 2)
- ㉑ **🎧** - Headphone connection
- ㉒ **AVS** - Mini AV socket <sup>†</sup>
- ㉓ **SPDIF IN** - Digital sound input
- ㉔ **USB** - USB connection
- ㉕ **USB** - USB connection

<sup>†</sup> Adaptor set is available as an accessory (see page 145).

## Installing the TV set

### Mounting options

Your Loewe specialist dealer can assist you in finding other mounting options that correspond to your needs. Use exclusively Loewe mounting options (e.g., wall bracket, floor stand), which you will find in the chapter entitled Accessories - Mounting options on page 147.

After you have decided on a mounting option, follow the directions found in the corresponding assembly instructions.

### Installation notes

Choose a place for installing your TV set where no bright light or sunlight shines directly onto the screen. This could cause reflections which impair the picture.

3 times the screen diagonal can be taken as a guide value for the viewing distance (e.g., for a 46-inch set approx. 3.5 m for SD signal). The viewing distance can be reduced with an HD signal.

## Set covers

### Covers for rear and side connections

In order to remove the rear side cable cover pull them simply from the device.

To attach the cable cover, place the lugs of the cover at the corresponding cut-outs in the rear panel.

Press the cover into the cutouts until the lugs snap into the device. Press only on the exact positions where the lugs are (see figure for the positions), otherwise the glass rear panel may be damaged.

The side cover of the TV set can also be completely removed. For this, open it as far as it will go and gently pull on the open cover.

The cover detaches from the holder and gives free access to the connection area. To replace the cover, simply push it until it latches back into place.

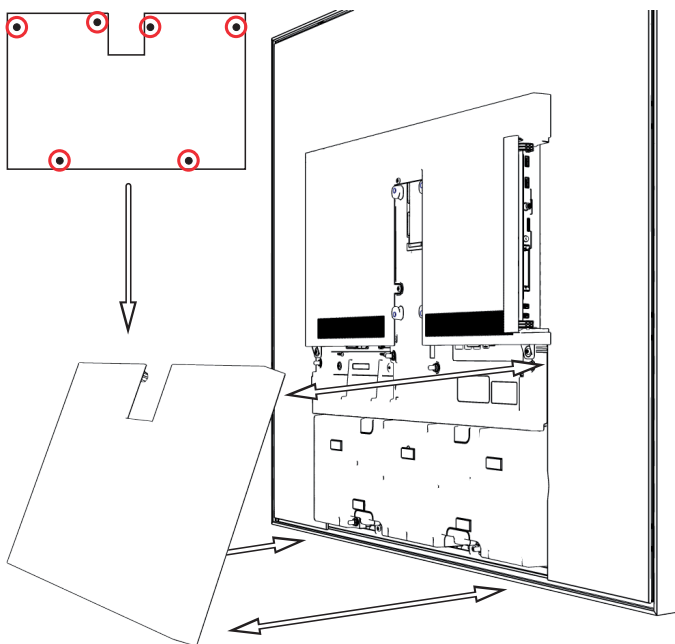

## Connecting the TV set

### Connecting to the mains supply

Remove the cover for the connections.

Connect the TV set to a 220-240V mains socket:

First plug the small plug of the power cable into the mains connection on the back of the TV and then the large mains plug into a mains socket.

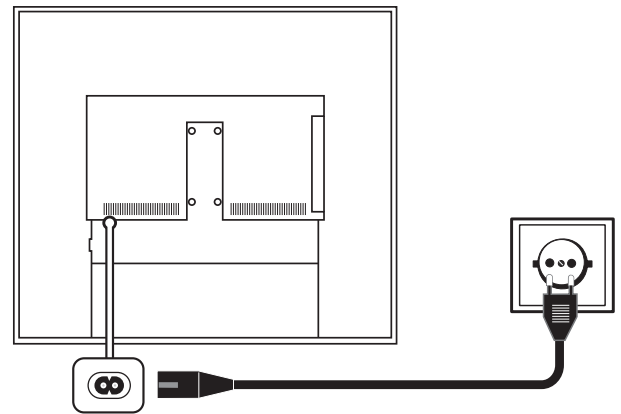

### Connecting antennas

Cable (analogue) / DVB-C / DVB-T antenna:

Plug the cable of antenna, cable TV system or room antenna into the **ANT TV** socket.

If you want to use analogue cables / DVB-C connection and a DVB-T antenna together, use an external antenna switch (available from your dealer).

Satellite antenna DVB-S:

Depending on the used satellite system, connect a connecting cable from the multi-switch or directly from the LNC to the **ANT-SAT** and **ANT-SAT2** sockets of the TV set respectively.

When connecting the TV set to a single cable community antenna, connect the **ANT-SAT** and **ANT-SAT2** sockets directly to the appropriate SAT antenna socket.

When connecting the TV set to a **DiSeqC single cable community antenna** (in accordance with EN 50494), connect the **ANT-SAT** socket directly to the appropriate SAT antenna socket.

**I** In case of a DiSeqC one cable communal system you require only **one** antenna cable. Further distribution of the signal to the two reception routes is accomplished by the TV set's satellite tuner.

Ask your dealer in this regard.

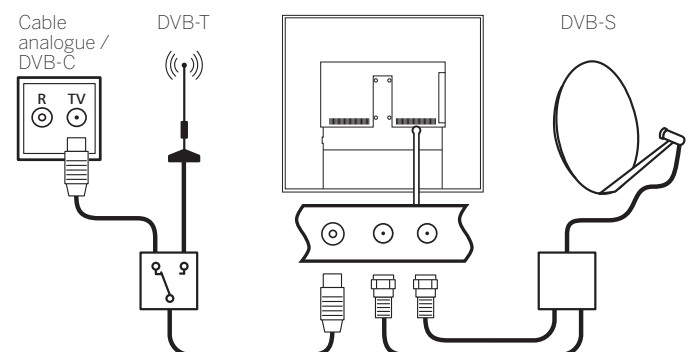

### Connecting the TV set to the Home network

You may link your TV set to the home network by a **wired connection** (Ethernet, Powerline) or by a **wireless radio connection** (WLAN). Please contact your specialist dealer for more information on Powerline.

For the network adaptor configuration, see page 114.

**Under no circumstances** may the TV set be **wired** and at the same time connected by a **wireless connection** to the same network, e.g. router. This may cause severe operational faults!

#### Example for a wired connection

Connect the LAN socket of your TV set to the LAN switch/router of your home network with a network cable (available from your dealer).

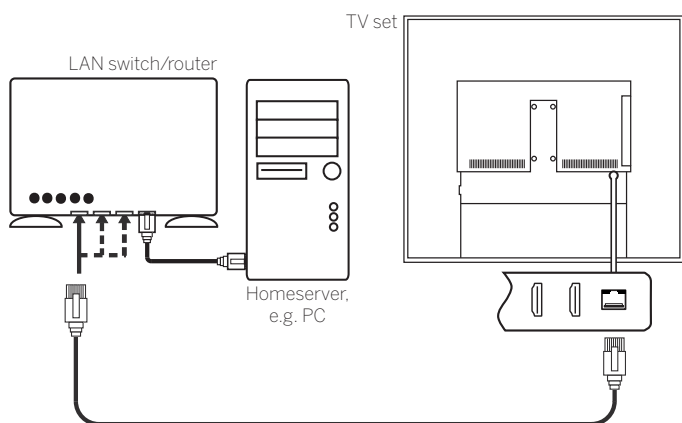

#### Example for a wireless connection

You can connect the TV set to your home network by a wireless radio connection via the WLAN antenna inside the set.

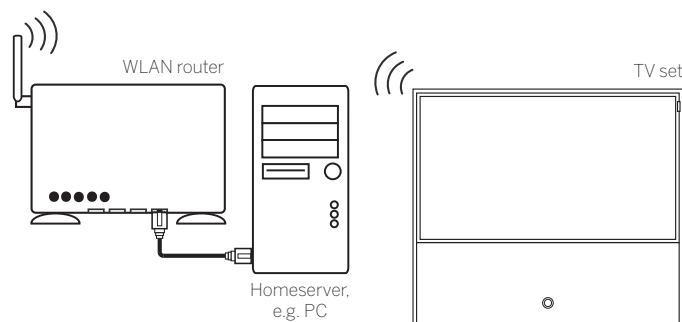

### Bundling the cables

Bundle the connected cables at the middle of the TV set and feed the cables through the cutout in the cover.

Then attach the cover for the connections (as described on page 12).

The cables connected to the TV set are held by the cover and fixed on the TV set.

Depending on the installation version, the cables should be laid accordingly (see installation instructions of the mounting option).

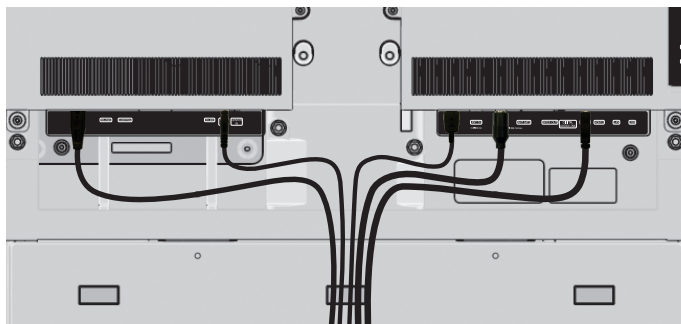

### Preparing the remote control unit

#### Inserting or replacing batteries

Press on the embossed arrow whilst pushing the battery cover down.

Only use leak-proof micro-cells of the LR 03 (AAA) Alkali-Manganese type. Do not use different types of batteries and old and new batteries together.

The batteries used must not be exposed to excessive heat such as sunlight, fire or similar!

Pay attention to the correct polarity of + and - when inserting the batteries.

If the batteries are too weak after longer use, the TV set prompts you to change the batteries.

Dispose of used batteries in an environmentally friendly way (see page 148).

Push the cover back on from below after having inserted the batteries.



#### Adjusting the remote control for operating the TV set



Press the **TV key**.

See page 133 for how to operate other Loewe appliances and how to re-programme the remote control keys.

## Switching the TV set ON/OFF

### Switching TV set to the standby mode

Press the mains switch at the rear side of the set.

The indicator in the Loewe eye on the front side lights up white. The set is now in standby mode.

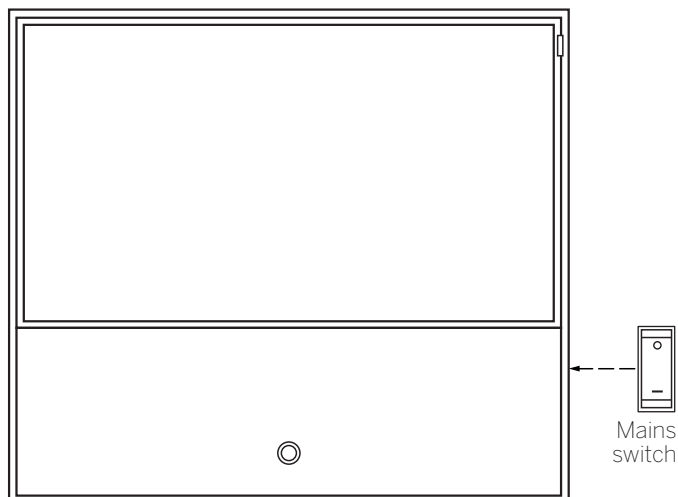

### Switching the TV set on/off via the local operating panel

To switch the TV set into operating mode or switch it off to standby mode, press the button on top of the set for about 2 seconds.



Meaning of the colour of the LEDs in the Loewe eye:

	white:	Standby
	white, intermittent:	TV set starts
	green:	TV set switched on
	red:	Timer recording active
	blue:	TV set in standby, background operation active (EPG data updating, software update or DR+ streaming server function)

**i** Further operation commands will only be handled after several seconds after switching on the TV set.

### Switching the TV set on by means of the remote control

Press the **on/off key**

Or:

Press the **TV key**.

Or:

Press **numerical keys 1-9**

The previously watched station will be called.

**i** Further operation commands will only be handled after several seconds after switching on the TV set.

### Switching the set off with the remote control (Standby)

Press the **on/off key**.

**i** Before switching off the set with the mains switch, we recommend you to switch it to standby mode.

### Switching off the TV set and connected additional devices (System standby)

Press **on/off key** long:

Switch TV set and all CEC-capable devices connected to the **HDMI** interfaces OFF to Standby mode (System Standby).

## Technical information

Switching off the TV set with the mains switch during operation or an inadvertent disruption to the power supply (e.g. power failure) can cause damage to the hard disk file system and hence loss of the recorded broadcasts. **Always** return the TV set to Standby mode before switching it off with the main switch. Never ever disconnect the USB storage device from the TV set during a copy process.

However, if unexpected problems occur when operating the hard disk, formatting the hard disk may rectify this. Refer to the instructions on page 113. Also follow the information for formatting on page 113 when using an external USB hard disk.

Loewe are not liable for the loss of data on the integrated hard disk of your TV set. To avoid data loss, we recommend copying important recordings to an external storage medium.



## General information on menu operation

Some keys of the remote control for operating the TV set you will use more often than others. The most important keys for navigation will be explained in general. The numbers in the text refer to the figure showing the remote control on page 9.

The **arrow keys** (22) help you to navigate in the menus and lists of the TV set and for selecting menu items. They are arranged in the middle of the remote control in a circle around the **OK** key (11). Later in this quick guide they will be represented as follows:



The **OK** key (11) is used to confirm a selection, for calling the highlighted menu item and for opening the station list. In this quick guide, an instruction for this key looks like the following:

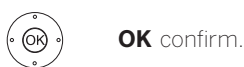

Using the **numerical keys** of your remote control (29) you enter programme channels and teletext pages directly. With key **0** you open the AV options. In this user guide, entering numbers with numerical keys is shown as follows:

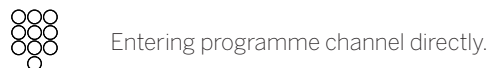

The numerical keys are also used to enter text (see **Entry of characters by remote control** on page 17).

The **Home** view is the central overview page for all of your TV set's operating modes. You reach **Home** view with the **HOME** key (27).



Pressing the **BACK** key (24) briefly brings you one level up in the wizard. Pressing the **BACK** key longer closes all opened fade-ins. An example for the **BACK** key in this quick guide:



If the function for a key is not available, this will be indicated by an inserted symbol (no) on the right above.

## Structure of the Menu screen

Basically, the structure of the different menu screens is similar, depending on the fact if a wizard, rendering media content or a setup menu are concerned. The structure is explained by means of three different screens.

The functions of these menu screens are explained more detailed in the respective chapters.

### Screen structure: Wizard

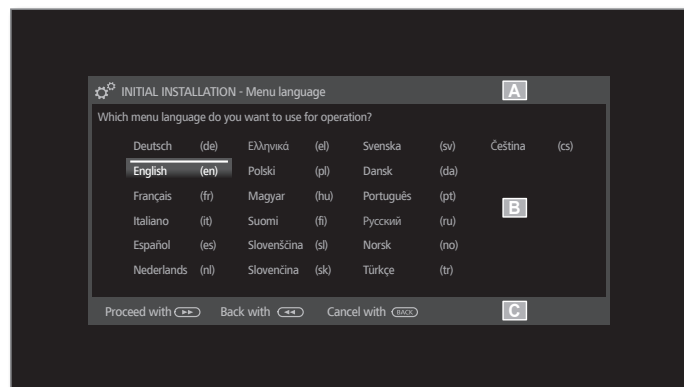

(A) Title bar with name of the wizard and the current operating step.

(B) Selected items, whose number can be different according to the operating step.

(C) Bottom line showing the available operating controls. If required, instructions and information are inserted.

### Screen structure: Rendering of media content (example: Audio player)

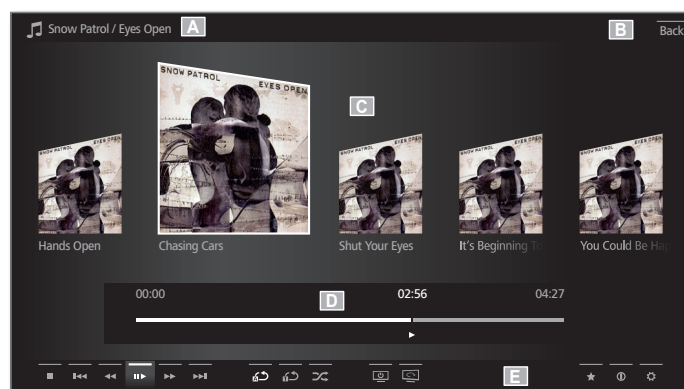

(A) Title bar with selected album / subdirectory.

(B) Menu item **Back** to exit the menu or to go back to the previous menu item.

(C) Selection of album or title

(D) Time bar

(E) Bottom line with the different symbols for controlling the playback function.

### Screen structure: Setup (example: picture)

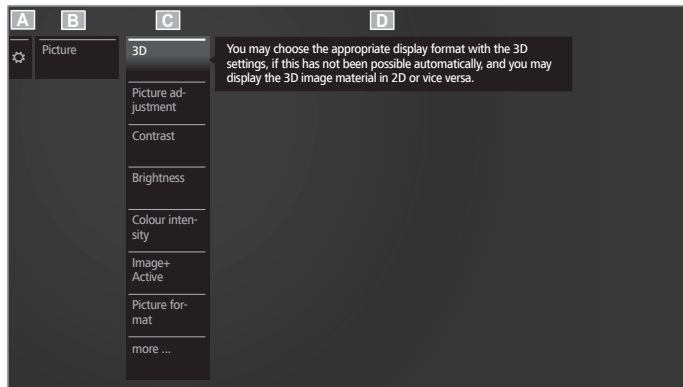

- (A) Selected function in the Home overview (here: system settings)
- (B) Home Menu **System settings**, with selected menu item **Picture**.
- (C) Menu items **Picture** focusing on **3D**
- (D) Help text for the selected menu item **Picture > 3D**

### Navigation: Selection of elements (example: On-screen displays)

Highlighting and thus selecting the symbols/elements or menu items on the screen can be effected by the arrow keys on the remote control. So you can see all the time where you are. As soon as there is a bar above a symbol or text, this is a selected element.

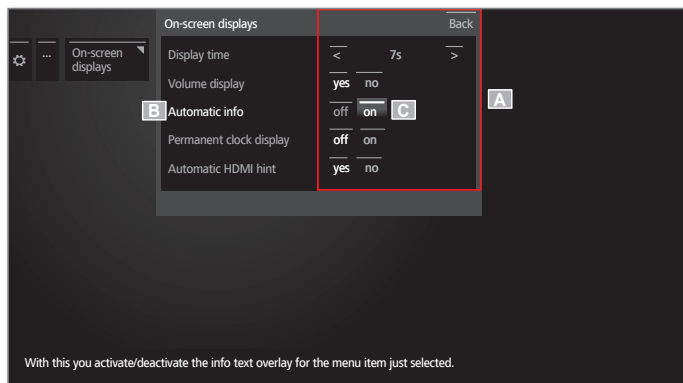

- (A) Selectable elements / menu items.
- (B) The text in the line where the marker is currently located is white.
- (C) Move the selection marking by means of the arrow keys ◀ ▶ ▲ ▼ to the menu item to be set.

In most cases, the marked menu item will be automatically adopted. The font colour of the previously active item will change to grey, that of the newly selected item to white.

**i** In a few menus, to confirm a selected menu item is required by pressing **OK**.

### Navigation: Wizards

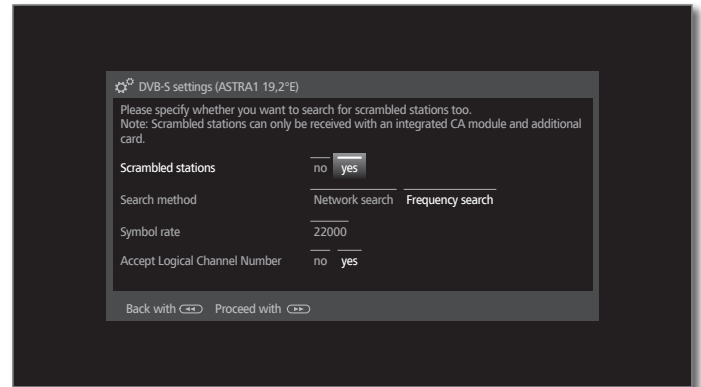

If the menu item(s) (marked white) is/are already correctly preset:



Go to next step.



Otherwise:

◀ ▶ ▲ ▼ Mark the menu items to be changed. The update will be adopted automatically. The font colour of the previously active item will change to grey. If not,

**OK** confirm the selection.



Go to next step.

## Entering characters with on-screen keyboard

For certain functions, entering letters or characters is required, e.g., for Web addresses (URLs) in the browser or for renaming archive entries. An on-screen keyboard appears for entering text.

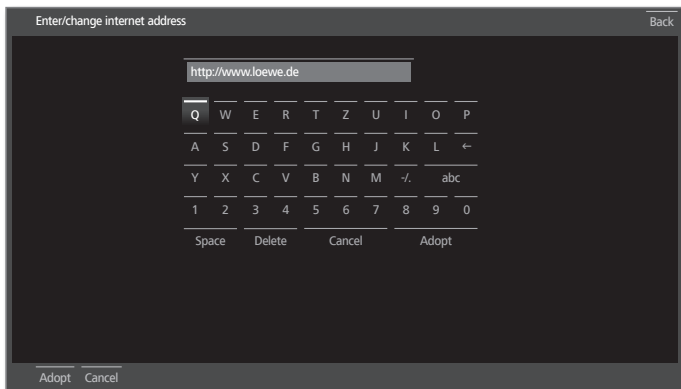

◀ ▶ ▲ ▼ Highlight character / on-screen button, **OK** adopt character.

For the selection of special characters select field **-./** several times briefly in rapid succession.

To conclude the entry:

◀ ▶ ▲ ▼ Mark **Adopt**, confirm with **OK**.

## Entry of characters by remote control

Alternatively to the on-screen keyboard you can also enter the desired characters by means of the remote control (as with the keypad of a mobile phone).



◀ ▶ ▲ ▼ Mark text entry field.

Under the 1st letter of the name you will see a line indicating the current input position.

- ▶ Input position one character to the right (also for blanks).
- ◀ Input position one character to the left.



Input the letters one after another. When using the remote control, press the **numerical keys** just as on a mobile phone keypad (0-9) until the desired symbol is displayed. The available letters are printed on the individual numeric buttons.

You find the exact key assignment in the character table in the right column.

To conclude the entry:



◀ ▶ ▲ ▼ Mark **Adopt**, confirm with **OK**.

## Table of characters for entering text by means of the remote control

Key	Characters (uppercase - lowercase)
1	[space] 1
2	A B C 2 Ä Æ Å Æ Å Á Á Ć Ć Ć - a b c 2 ä æ å ä å á á ć ć ć
3	D E F 3 Ę Ę Ę Ę Ę Ę Ę - d e f 3 ę ę ę ę ę ę ę
4	G H I 4 Ĩ Ĩ Ĩ Ĩ Ĩ Ĩ Ĩ - g h i 4 ĩ ĩ ĩ ĩ ĩ ĩ ĩ
5	J K L 5 - j k l 5
6	M N O 6 Ö Ö E Ö Ö Ö Ö Ö Ö - m n o 6 ö ö e ö ö ö ö ö ö ö
7	P Q R S 7 - p q r s 7
8	T U V 8 Ū Ū Ū Ū Ū Ū Ū - t u v 8 ū ū ū ū ū ū ū
9	W X Y Z 9 - w x y z 9
0	. 0 - / _ : + , ; ? ! = & # % ~ @ \$ * ' ( ) " § \ { } [ ] < > ' ` ^

## Info display

The info display provides an info text appropriate to the on-screen display that can assist you further with the operation of your TV set.

**i** An on-screen display is faded in.

(INFO)

The factory setting is that the info display is shown automatically for each menu item. In this case you can temporarily hide the info texts with the **INFO key**.

The automatic info display can be hidden via a menu setting. Then it can be displayed temporarily by pressing the **INFO key**.

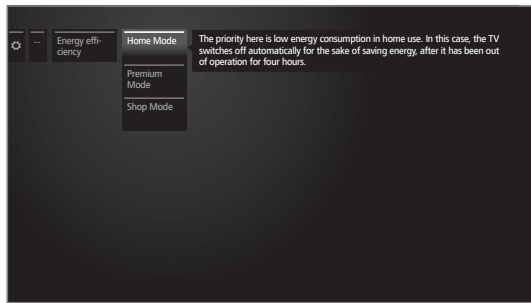

## Permanently display or hide the automatic info display

Once you have become familiar with how to operate the TV set, you can switch off the automatic info display.

(HOME)

**HOME:** Call **Home** view.



◀ ▶ ▲ ▼ Mark **System settings**,  
**OK** call system settings.

▼ ▲ Mark **Control**,  
▶ go to next column.

▼ ▲ Mark **more ...**,  
▶ move to next column.

▼ ▲ Mark **On-screen displays**,  
▶ call on-screen display settings.

▼ ▲ Select **Automatic info**,  
▶ select **on / off**.

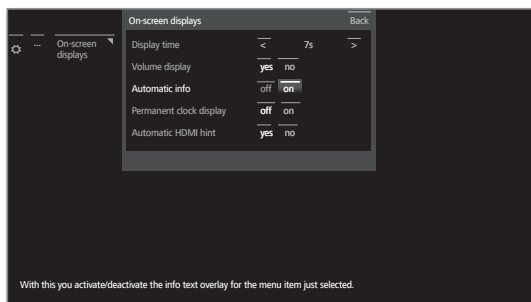

With this you activate/deactivate the info text overlay for the menu item just selected.

**OK** adopt settings.

## Operation without remote control

### Local control at the TV set



### Changing volume

- VOL + Increase/reduce volume.

### Switching radio on or off or switching to radio

RADIO Turn on the radio or switch between TV and Radio.

### Calling direct control on TV set

MENU Call direct control on TV set.



**RADIO:** Scroll down.

**MENU:** Scroll up.

- Scroll to the left.

+ Scroll to the right, accept settings, confirm.

### Close all displays

MENU Press longer.

### Explanations of the settings:

Operating mode Switch between TV and radio operation.

Station selection Call Station selection.

AV selection Select AV interface.

3D Calling 3D settings.

Contrast Set contrast.  
The power consumption of the TV set depends directly on the value set here.

Picture format Selecting the picture format.

Service **i** The Service menu item is provided for service purposes by dealers only.



## LED backlighting

The LED backlighting <sup>†</sup> turns your TV set into a shining decoration object.

The LED backlighting is temporarily controlled via the local control of the TV or the remote control.

**i** The function of the LED backlighting is reset to the default of the general preset of **System settings → Control → more ... → LED light module** (see page 110) as soon as the TV set changes its operating mode (switching on or off).

**i** For playback of movies in 3D mode (see page 88) we recommend to disable the LED backlighting <sup>†</sup>.

**i** When activating the LED backlighting with TV set switched off (standby mode), further operation commands will only be handled after several seconds.

### Controlling the LED backlighting via the local control



✱ Press briefly: Switch the LED backlighting temporarily on/off.

✱ Press longer: Change brightness of the LED backlighting (dim the lighting).

As long as you keep the ✱ **key** depressed, the display is in an endless loop alternately reducing the lighting to its minimum and then increasing it to the maximum again.

When desired brightness is reached:

Release the ✱ **key**.

### Controlling the LED backlighting via the remote control



Press briefly: Switch the LED backlighting temporarily on/off.

When backlighting is active and when there are no further on-screen menu displays:



▲ ▼ Increase / decrease brightness of the LED backlighting.

<sup>†</sup> Depending on the type of TV set.

## Initial installation wizard

### Initial installation after switching on for the first time

The Initial installation wizard starts automatically with an initial installation. It may be called repeatedly again (see **Repeat initial installation** on page 83).

**i** If at least one station is locked, the access code must be entered before repeating initial installation (see Parental lock on page 100).

**i** For information on navigation within the wizard refer to **General information on menu operation** on page 16.

### First installation wizard routine

The selected settings affect the routine of the Initial installation wizard.

Menu language

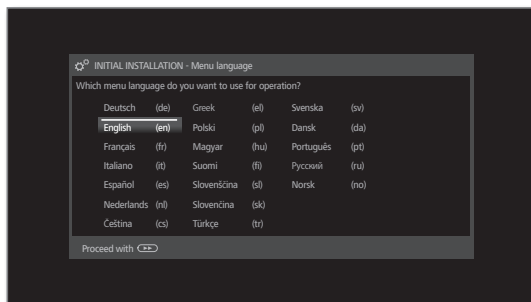

▲ ▼ ◀ ▶ Select desired **Menu language**.

Selecting the language of the user guidance is the wizard's first step. Then you simply follow the instructions on your TV screen.

Conclude this step (for navigation refer to page 16).

Energy efficiency

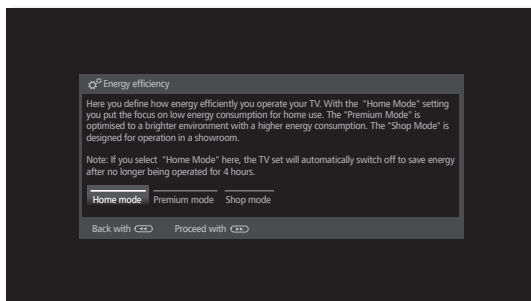

◀ ▶ Select **Energy efficiency**.

Determine how energy efficient your TV set shall be. The value for the contrast (and thus the brightness of the background lighting) is adapted and the automatic dimmer activated or deactivated (see page 86) depending on the presetting.

Choosing **Home mode** automatically activates shutdown. For **Premium mode** or **Shop mode**, automatic shutdown is initially deactivated.

See page 6 for further information on automatic shutdown.

Energy efficiency (continued)

### Home mode:

The emphasis for home use is on low energy consumption. The automatic dimmer is activated.

### Premium mode:

This mode optimises the settings to a brighter environment at a higher energy consumption. The automatic dimmer is activated.

The use of this energy efficiency setting must be confirmed afterwards once again.

### Shop mode:

The picture settings are aligned to operation in the presentation room. The automatic dimmer is deactivated. If the ambient brightness diminishes, the energy consumption is not reduced.

The use of this energy efficiency setting must be confirmed afterwards once again.

**i** The presetting can be changed later in **Extras → Energy efficiency** (see page 101) or in the **System settings** under **Picture → Picture adjustment** (see page 87).

Conclude this step (for navigation refer to page 16).

Location of TV set

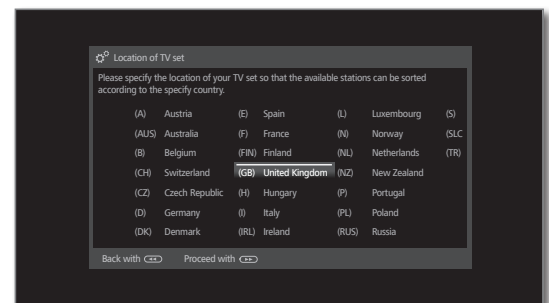

▲ ▼ ◀ ▶ Select **Location of TV set** (national defaults are adopted).

For certain locations (e.g., Australia), there is finally a selection screen where you can indicate in which state/territory the device is being operated.

Conclude this step (for navigation refer to page 16).

## Selecting antennas

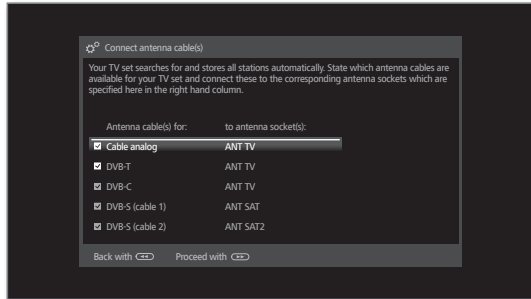

▲ ▼ Select antenna cable.

**OK** Connect/disconnect antenna cable.

Ahead of each selected antenna, the symbol  appears.

**Cable (analogue):** analogue stations via cable  
**DVB-T:** digital terrestrial stations  
**DVB-C:** digital stations via cable  
**DVB-S (cable 1):** digital stations via satellite  
**DVB-S (cable 2):** digital stations via satellite

Conclude this step (for navigation refer to page 16).

## Subtitle and audio languages (DVB only)

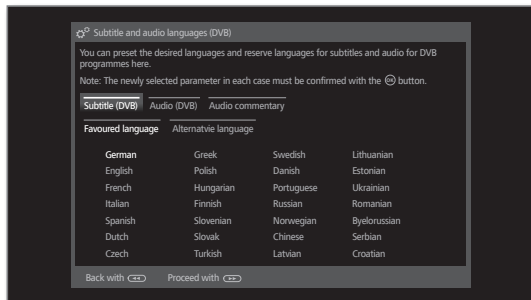

▲ ▼ ◀ ▶ Select desired languages and alternative languages for subtitles and audio for DVB programmes (see page 99).  
 Set up audio commentary for the visually impaired (see page 105).

Conclude this step (for navigation refer to page 16).

## Extent of station search

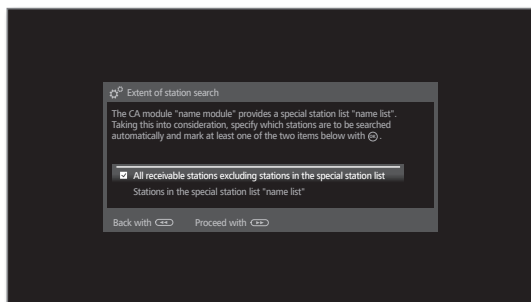

▲ ▼ Considering the plugged CA module(s) specify which stations should be searched automatically. If the CA module(s) do(es) not support this function or if no CA module is plugged in, this step will be skipped.

Conclude this step (for navigation refer to page 16).

Depending on the antennas (analogue cable, DVB-T, DVB-C, DVB-S) selected, the appropriate settings appear below.

## Setting options for reception via analogue cable:

If you have not selected Cable analog in the list of available antennas: Proceed to **Setting options for DVB-T reception** on page 22.

**i** The selection of a Colour standard is only required when the Location of TV set **Other country** was selected (see page 20). Otherwise, the country-specific default settings will be preset when selecting the Location of TV set. This step will be skipped then.

## TV/col. standard

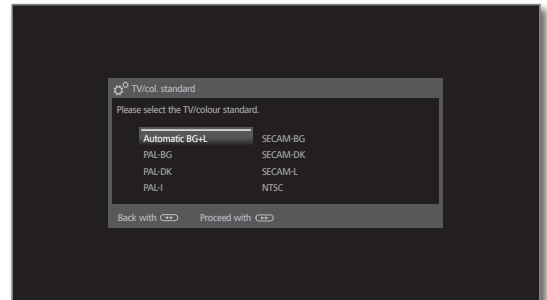

▲ ▼ ◀ ▶ Select appropriate colour standard.

Conclude this step (for navigation refer to page 16).

### Setting options for DVB-T reception:

If you have not selected DVB-T antenna in the list of available antennas: Proceed to Setting options for **DVB-C reception** on page 23.

**I** If a CA module is plugged in during Initial installation and if **Stations in the special station list** was selected in **Extent of station search** (see page 21), the routine continues with the step **Supply voltage** (see right column).

Network selection

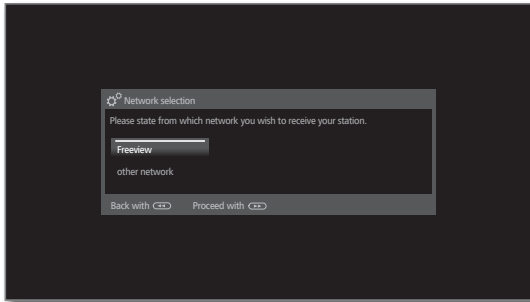

If several networks are available via DVB-T, you can decide which network you want to receive your channels from.



▲ ▼ Select network,

Conclude this step (for navigation refer to page 16).

Settings

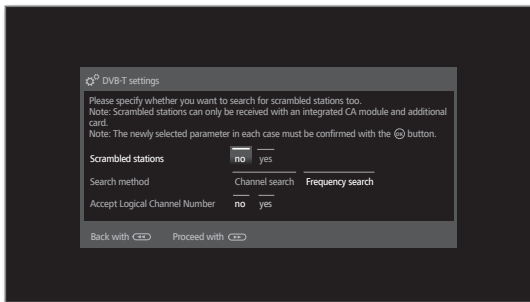

▲ ▼ ◀ ▶ Select and adapt settings for DVB-T reception.  
**OK** Adopt settings.

**Scrambled stations** You can state whether coded stations are to be searched for in the search/update. Select **yes** to save all found scrambled stations. However, these stations can only be received in connection with a CA module and the appropriate Smart Card. Handling of the CA module is described on page 81.

**Search method** If you want to run the station search independently of the channel grid, select **Frequency search** for the search method.

**Accept Logical Channel Number** In various countries, digital stations (DVB-T) are transmitted with a preset channel number per station, known as Logical Channel Numbers (LCN). If you select **yes** here, these default channel slots will be used and the channels of the preferred signal source will be sorted as per LCN. The stations in the station list can no longer be shifted (see **Move block / Change order** on page 95).

Conclude this step (for navigation refer to page 16).

Supply voltage

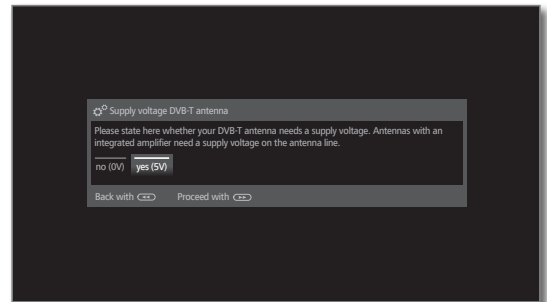

◀ ▶ Select supply voltage **no / yes**.

If you use a DVB-T antenna that requires a supply voltage (active antenna) and which is not already supplied via a power adaptor, then select **yes (5V)** for the antenna's power supply.

How to align your DVB-T antenna is described on page 123.

Conclude this step (for navigation refer to page 16).

### Setting options for DVB-C reception:

If you have not selected DVB-C antenna in the list of available antennas: Proceed to **Setting options for DVB-S reception** (see page 24).

**I** If a CA module is plugged in during Initial installation and if **Stations in the special station list** was selected in **Extent of station search** (see page 21), the routine continues with the step **Setting options for DVB-S reception** (see page 24).

Network selection

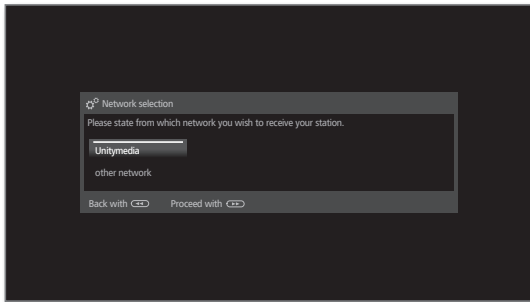

If several networks are available via DVB-C, you can decide which network you want to receive your channels from. The normal DVB-C settings are derived from the selection of the location or network and do not need to be changed. Exactly which of the following settings are present is dependent on which network is selected.



▲ ▼ Select network.

Conclude this step (for navigation refer to page 16).

Settings

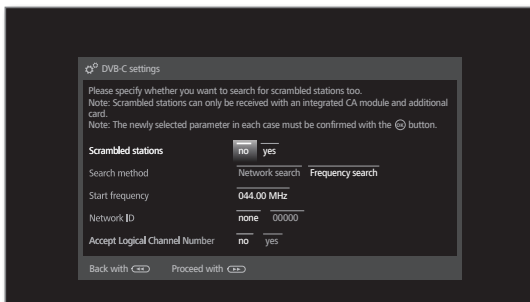

▲ ▼ ◀ ▶ Select and adapt settings for DVB-C reception.

**OK** Adopt settings.

**Scrambled stations** You can state whether coded stations are to be searched for in the search/update. Select **yes** to save all found scrambled stations. However, these stations can only be received in connection with a CA module and the appropriate Smart Card. Handling of the CA module is described on page 81.

**Search method** If you select **Frequency search** here, a search is performed for all receivable stations. With **Network search**, only the stations which the networks supply are searched - either for all receivable networks or only for the particular network specified under **Network ID**.

**Start frequency** The DVB stations are only searched for in the frequency range above the start frequency.

**Network ID** If you select **none** here, DVB signals of all current transmitter networks are searched automatically (recommended for most cable networks). If, on the other hand, you specify a certain network ID (necessary in the cable networks of some countries), only DVB signals of this broadcasting network are searched for automatically. Your cable provider has the information you need.

**Accept Logical Channel Number** In various countries, digital stations (DVB-C) are transmitted with a preset channel number per station, known as Logical Channel Numbers (LCN). If you select **yes** here, these default channel slots will be used and the channels of the preferred signal source will be sorted as per LCN. The stations in the station list can no longer be shifted (see **Move block / Change order** on page 95).

Conclude this step (for navigation refer to page 16).

### Setting options for DVB-S reception:

If you have not selected DVB-S antenna in the list of available antennas: Proceed to **Setting options for all types of reception** on page 30.

Select  
satellite  
installation

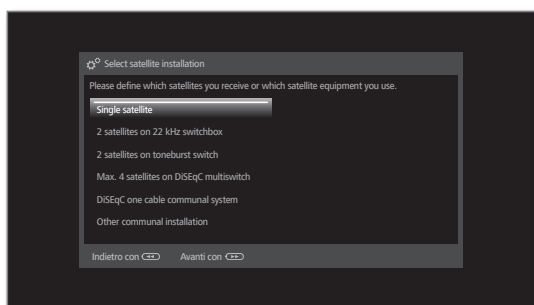

#### ▲ ▼ Selecting the satellite system.

Specify how you receive which satellite(s) (single satellite or type of satellite system). Ask your dealer in this regard.

The normal DVB-S settings are derived from the selection of the location and do not need to be changed in most cases.

Single satellite	Reception of a single satellite via a connected LNC (LNB). See page 25 for settings.
2 satellites on 22 kHz switchbox	Reception of two different satellites with two LNCs (LNBs) which are connected to the TV set by a 22 kHz switchbox. See page 25 for settings.
2 satellites on toneburst switch	Reception of two different satellites with two LNCs (LNBs) which are connected to the TV set by a toneburst switch. See page 25 for settings.
Max. 4 satellites on DiSEqC multiswitch	The TV set controls a DiSEqC multiswitch to which up to four LNCs (LNBs) for different satellites are connected. See page 26 for settings.
DiSEqC one cable communal system	Select setting if the TV set is connected to a DiSEqC single-cable system (according to EN 50494). Several Sat receivers can be connected to one Sat cable. See page 27 for settings.
other communal installation	Select setting if the TV set is connected to a single-cable system (without DiSEqC). Several Sat receivers can be connected to one Sat cable. Contrary to a DiSEqC one cable communal system there are restrictions in the range of certain reception frequencies in "common" single-cable community systems. See page 28 for settings.

Conclude this step (for navigation refer to page 16) (Proceed to the appropriate page of the satellite system).

**Setting options for the satellite system (single satellite):**

Select single satellite

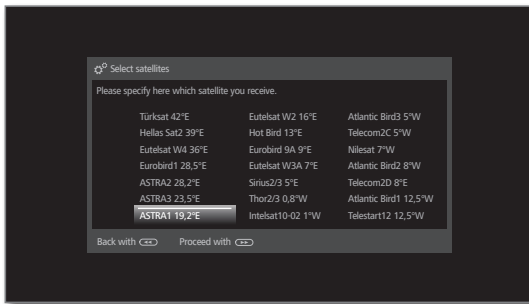

▲ ▼ ◀ ▶ Select satellite.

Conclude this step (for navigation refer to page 16).

Dual/single band

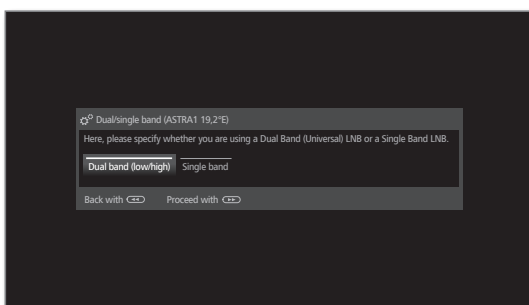

◀ ▶ Select **Dual band (low/high)** or **Single band**. Here you specify if you use a Dual Band (Universal) LNB or a Single LNB.

Conclude this step (for navigation refer to page 16).

LNC frequencies

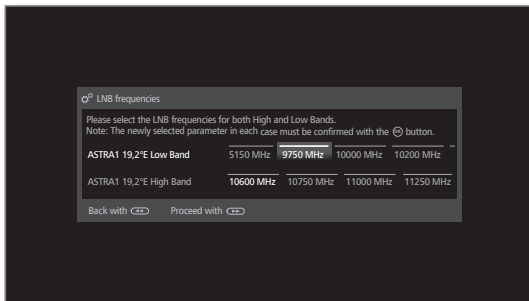

▲ ▼ ◀ ▶ Set LNB frequencies.

**OK** Adopt settings.

Normally, you do not need to change the values for high and low band, unless the LNC (LNB) of your satellite system uses a different oscillator frequency (important for the frequency display). If you use the setting **Single Band** in step **Dual/Single Band**, you only have to define the LNC frequency for the Low Band.

Conclude this step (for navigation refer to page 16).

(Proceed with **Setting options for DVB-S reception (continued)** on page 29).

**Setting options for the satellite system (2 satellites on 22 kHz switchbox / 2 satellites on toneburst switch):**

Satellite selection

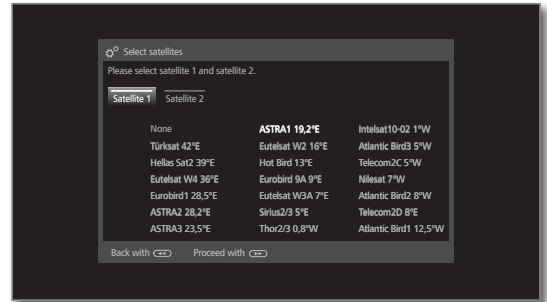

▲ ▼ ◀ ▶ Mark **Satellite 1 / Satellite 2**.  
▲ ▼ ◀ ▶ select satellite.  
**OK** Adopt settings.

Conclude this step (for navigation refer to page 16).

LNC frequency (22 kHz Switch box)

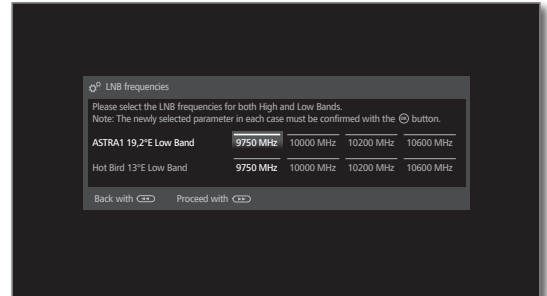

LNC frequencies (Toneburst switch)

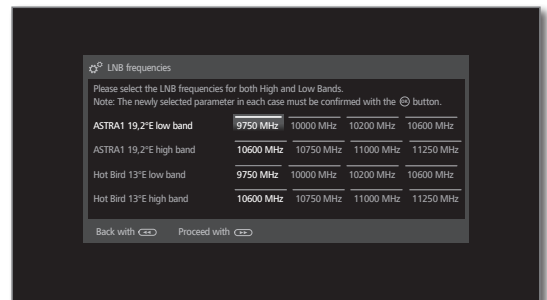

▲ ▼ ◀ ▶ Set LNB frequencies.  
**OK** Adopt settings.

Normally, you do not need to change the values unless the LNC (LNB) of your satellite system uses a different oscillator frequency (important for the frequency display).

Conclude this step (for navigation refer to page 16).

(Proceed with **Setting options for DVB-S reception (continued)** on page 29).



## Setting options for the satellite system (max. 4 satellites on DiSEqC multiswitch):

DiSEqC  
multiple  
switch

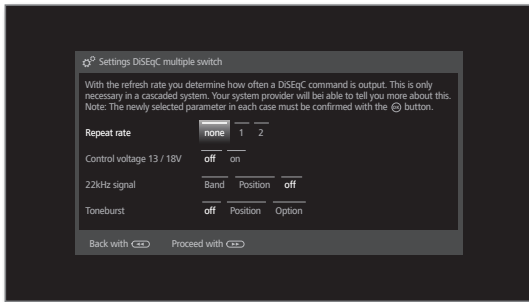

▲ ▼ ◀ ▶ Select and adapt settings for the DiSEqC multiswitch.  
**OK** Adopt settings.

**Repeat rate** The refresh rate determines how often a DiSEqC command is output. A refresh is only necessary with cascaded systems.

**Control voltage** The control voltage controls the switching of the polarisation level (horizontal/vertical) in non-DiSEqC capable components (e.g., control of single LNBs via DiSEqC multiswitch).

**22kHz signal** The 22 kHz signal controls the switching between high and low band in the **Band** setting. The **Position** setting controls the selection of the satellites in non-DiSEqC capable components.

**Toneburst** The Toneburst controls the selection of the satellites in non-DiSEqC but Toneburst capable components with the **Position** and **Option** settings.

Conclude this step (for navigation refer to page 16).

Satellite  
selection

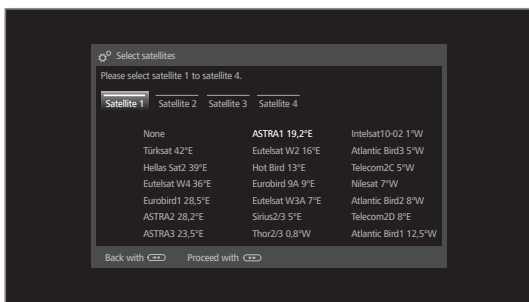

▲ ▼ ◀ ▶ Mark **Satellite 1 ... Satellite 4**.  
▲ ▼ ◀ ▶ Select satellite.  
**OK** Adopt settings.

Conclude this step (for navigation refer to page 16).

LNC  
frequencies

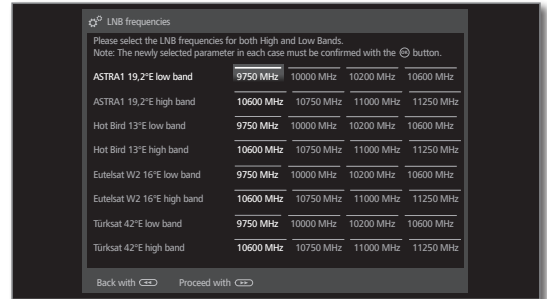

▲ ▼ ◀ ▶ Set LNB frequencies.  
Normally, you do not need to change the values.  
**OK** Adopt settings.

Conclude this step (for navigation refer to page 16).

(Proceed with **Setting options for DVB-S reception (continued)** on page 29).

## Setting options for the satellite system (DiSEqC one cable communal system):

Number of system channel used

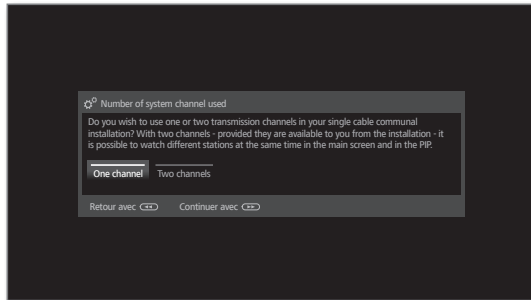

▶ Select **One channel** or **Two channels**.

Here you specify if you use one or two transmission channels in your one cable communal system.

In case of two channels - as far as they are available in your system - different stations can be simultaneously viewed on the main picture and on PIP.

You get more information on your system from your dealer.

Conclude this step (for navigation refer to page 16).

DiSEqC one cable communal installation

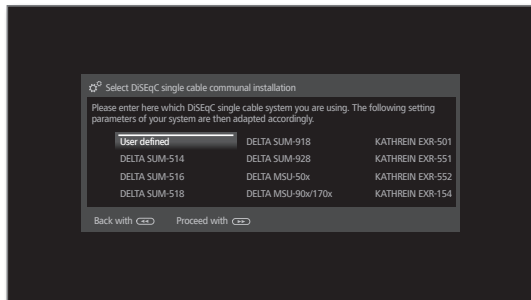

▶ Select DiSEqC single cable communal installation.

**OK** Adopt settings.

Conclude this step (for navigation refer to page 16).

Satellite selection

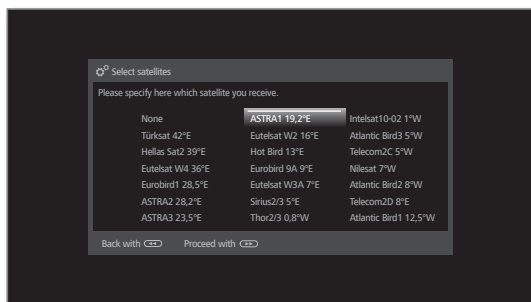

▶ Select satellites from list,

Conclude this step (for navigation refer to page 16)

LNB frequencies

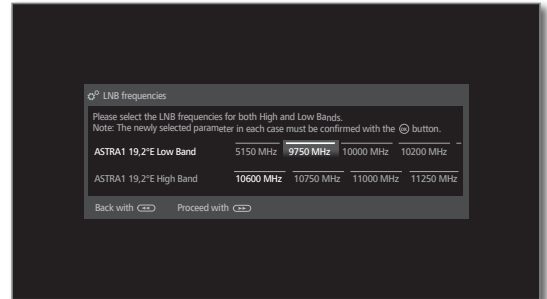

▶ Set LNB frequencies.

Normally, you do not need to change the values unless the LNC (LNB) of your satellite system uses a different oscillator frequency (important for the frequency display).

**OK** Adopt settings.

Conclude this step (for navigation refer to page 16).

Manual registration (for socket ANT SAT)

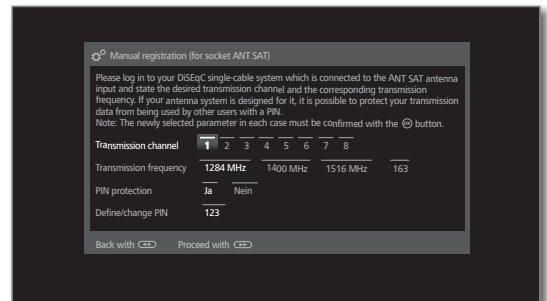

▶ Select and adjust settings for the DiSEqC single cable communal installation.

**OK** Adopt settings.

Transmission channel Select the desired transmission channel.

Transmission frequency Select the corresponding transmission frequency.

PIN protection If your system is designed for it, it is possible to protect your used transmission data from use by other subscribers with a PIN.

Define/change PIN Here you can determine and change the PIN for PIN protection. Only possible, when **yes** has been selected for PIN protection.

Conclude this step (for navigation refer to page 16).

(Proceed with **Setting options for DVB-S reception (continued)** on page 29).

## Setting options for the satellite system (other communal installation):

Select single satellite

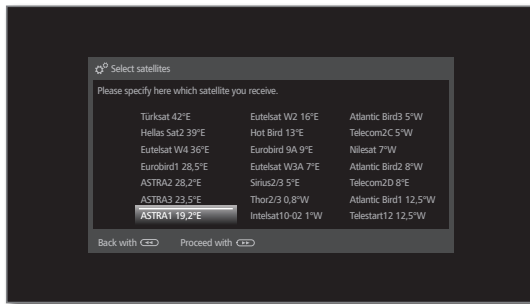

▲ ▼ ◀ ▶ Select satellite.

Conclude this step (for navigation refer to page 16).

LNB frequencies

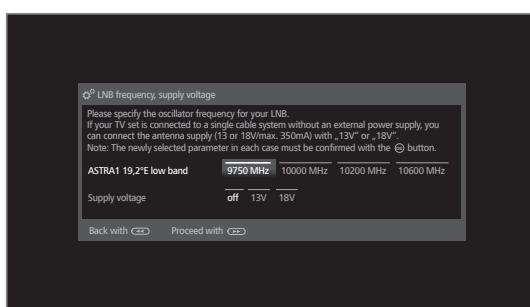

▲ ▼ ◀ ▶ Select and adapt settings.

**OK** Adopt settings.

**LNC frequency** Normally, you do not need to change the values for high and low band, unless the LNC (LNB) of your satellite system uses a different oscillator frequency (important for the frequency display).

**Supply voltage** If your set is connected to a single-cable system without external voltage supply, you can connect the antenna supply (13V or 18V / max. 500mA).

Conclude this step (for navigation refer to page 16).

(Continue with **Setting options for all types of reception** on page 30).

## Setting options for DVB-S reception (continued):

Test reception

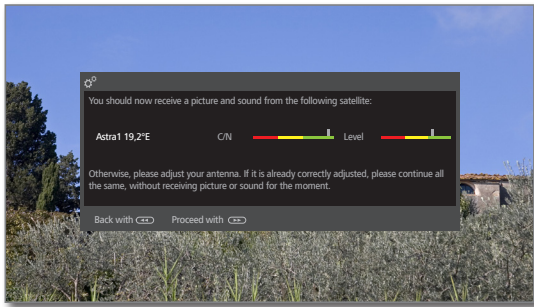

After you have made the previous settings, you should receive picture and sound of the selected satellites (only possible for Astra1 and HOTBIRD).

Conclude this step (for navigation refer to page 16).

Network selection

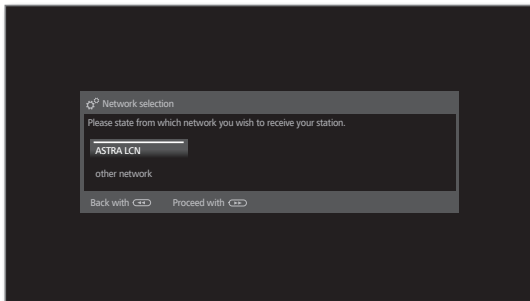

▲ ▼ Select network.

If several networks are available via DVB-S, you can decide which network you want to receive your channels from.

Conclude this step (for navigation refer to page 16).

Settings

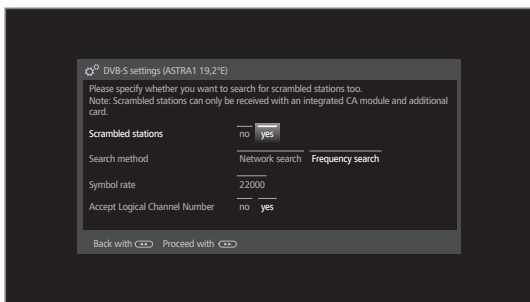

▲ ▼ ◀ ▶ Select and adapt settings.

**OK** Adopt settings.

If several satellites are received, the following settings must be made for every satellite. The type of settings available may differ depending on the selected satellite or network.

**Scrambled stations** You can state whether coded stations are to be searched for in the search/update. Select **yes** to save all found scrambled stations. However, these stations can only be received in connection with a CA module and the appropriate Smart Card. Handling of the CA module is described on page 81.

**Search method** If you select **Frequency search** here, a search is performed for all receivable stations. With **Network search**, from all receivable networks all the stations are searched which are supplied by these networks.

**i** Depending on the selected network, this step might possibly be skipped.

**Symbol rate** The symbol rate is specified by the satellite provider and normally does not need to be changed.

**Accept Logical Channel Number** In various countries, digital stations (DVB-S) are transmitted with a preset channel number per station, known as Logical Channel Numbers (LCN).

If you select **yes** here, these default channel slots will be used and the channels of the preferred signal source will be sorted as per LCN. The stations in the station list can no longer be shifted (see **Move block / Change order** on page 95).

Conclude this step (for navigation refer to page 16).

(Continue with **Setting options for all types of reception** on page 30).

## Setting options for all types of reception:

Check search settings

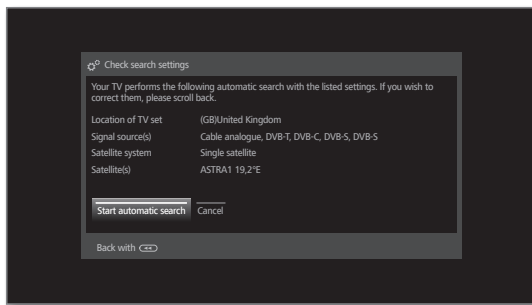

You will see a list of the selected settings. You can go back step by step with the key ◀ to make any changes to the settings.



### OK Start automatic search.

Now, the TV set searches for TV and radio stations. It searches successively for stations from the selected signal sources. The progress of search is shown by a progress bar.

**i** In case of a repeated initial installation routine (via **Home** view under **Extras** → **Special functions**) **all** stored stations will be first deleted here.

Info station search

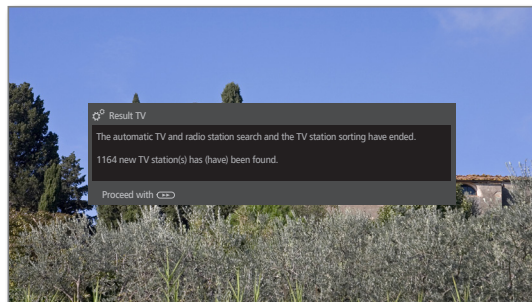

The number of found TV stations is displayed.



▶▶ Proceed.

The number of found radio stations is displayed.



▶▶ Proceed.

Age-related lock

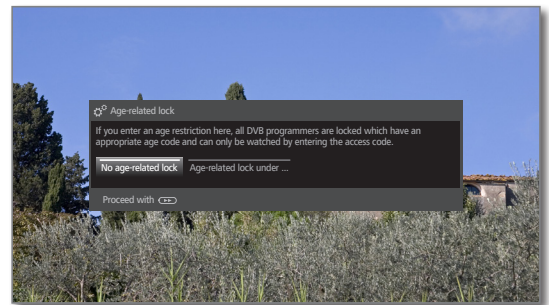

### ◀ ▶ Select Age-related lock.

You can specify an age limit for your TV set here. DVB broadcasts which have an appropriate age identification are locked and can only be watched after entering the access code (see page 100).

In some countries, the **yes/no** option does not exist for some channels, and a compulsory age check must be entered.

Conclude this step (for navigation refer to page 16).

Time and date

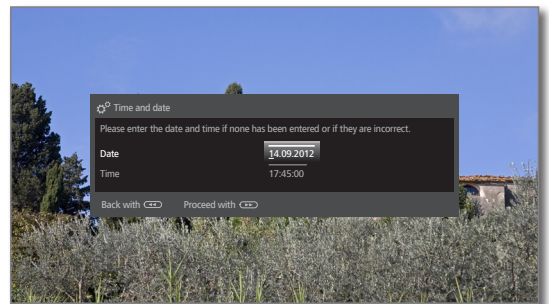

**i** Depending on the selected network, this step may be skipped.



### ▲ ▼ Select time / date.

If no values or no correct values have been entered for date and time, enter the correct values with the numerical keys here.

Conclude this step (for navigation refer to page 16).

## Sound playback via ...

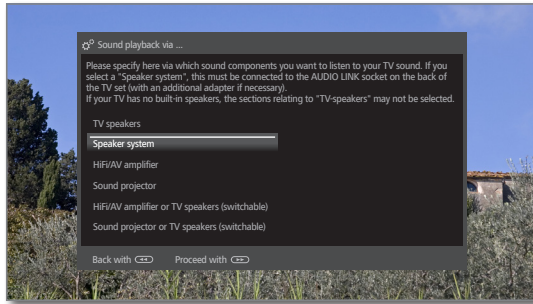

### ▲ ▼ Select sound components.

This selection indicates which sound components you want to use to hear your TV sound. Depending on the selection, the sound component wizard starts with which you can make further settings.

The sound component wizard is described starting from page 119 and can also be started at any time beyond the initial installation (**System settings** → **Connections** → **Sound components**).

Conclude this step (for navigation refer to page 16).

## Network configuration

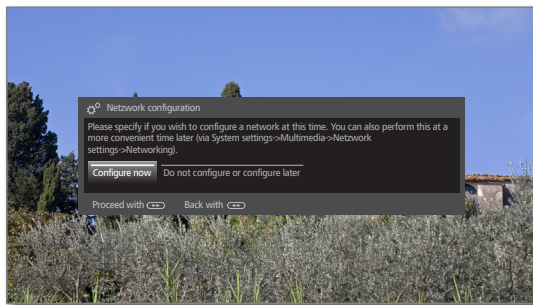

### ◀ ▶ Select option.

With the selection, specify whether you want to configure the available network adaptor now.

**Configure now:** Make settings for network adaptor (see page 114) and proxy server (see page 116).

**Do not configure or configure later:** Skip network adaptor configuration.

Conclude this step (for navigation refer to page 16).

## Software update info

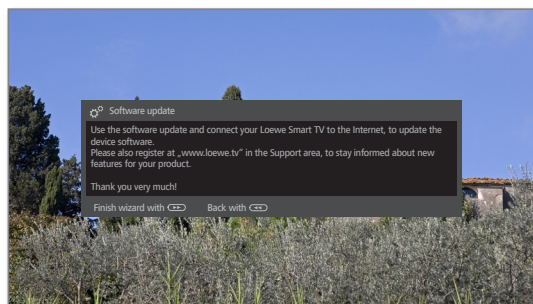

### ▶▶ Exit wizard.

The initial installation wizard is complete. Menu item **Software update** is called (see page 101).

## Home view

The **Home** view is the central overview page for all of your TV set's operating modes.

The list of options on the left of **Home** view gives you access to TV, Video, Audio/Radio, Photo and Web.

By means of **Extras** and **System settings** you have access to more functions and you can configure your TV set.

On the right side of the screen you find all your favourites (bookmarks) created in the different operating modes.

The number of selectable items varies depending on the TV equipment, network connection, available media/ media servers and connected appliances.

### Call Home view

HOME

**HOME:** Call **Home** view.

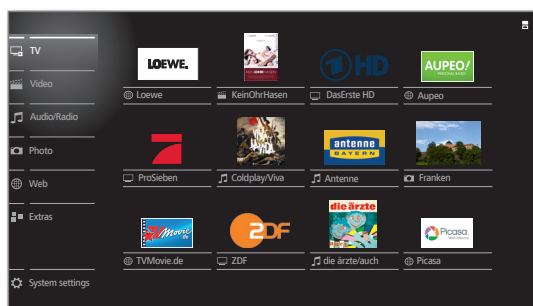

▼ ▲ ◀ ▶ Select menu item / favourite,  
**OK** call.

### Description of the individual sections/functions:

TV:



Here you call the **TV** mode of your TV set.

Further information you find starting from page 34.

Video:



The item **Video** gives you access to videos from local (USB, home network) and online sources.

Further information you find starting from page 55.

Audio/Radio:



With item **Audio/Radio** you find music files from your local server(s) and USB storage media and you access DVB and Internet radio.

Further information you find starting from page 64.

Photo:



Via menu item **Photo** you can view photos from your local media on your TV screen.

Further information you find starting from page 71.

Web:



Here you have access to multimedia content in the Internet (MediaNet) as well as a high-quality web browser.

Further information you find starting from page 74.

Extras:



**Extras** contains additional functions and setting (e.g., Timer list, CA module).

Further information you find starting from page 77.

System settings:



In menu item **System settings** you find the configuration menu of the TV set e.g., with setting for picture, sound, connections or sound components.

Further information you find starting from page 85.

### Activated operating mode

The respective activated operating mode will be indicated in the list of options by a small playback symbol in the lower right-hand corner of the **Home** symbol.

Examples:



TV mode activated.



Audio player (Audio mode) activated.

In the opened **Home** view, pressing again on the **HOME** key brings you back to the respective active operating mode.



## Home - Favourites

You will find your favourites on the right of the individual operating modes.

You can create favourites in the operating modes of the TV set. In this way you get a collection of your favourite music titles, your preferred stations and often visited Internet sites on a single overview page.

After an initial installation, TV stations, online links and radio stations will already be automatically created as favourites independent of the installation site of the TV set and of existing Internet links.

### Creating favourites

In the operating modes of the TV set you can define the current object (station, music title, photo, etc.) as favourite by means of your remote control.

The favourite will be added to **Home** view and placed at the end.



Create favourite.

If there are more favourites than can be shown on one page, this will be indicated by rectangular symbols in the upper right corner of **Home** view. Example:



Three pages with favourites exist. The first page of them is indicated.

### Manage favourites

You can edit the existing favourites in **Home** view. Change the sequence of your favourites as you wish or delete favourites you do not need any more.



**HOME:** Call **Home** view.



◀ ▶ ▲ ▼ Mark the favourite to be changed.



**MENU:** Change favourite.

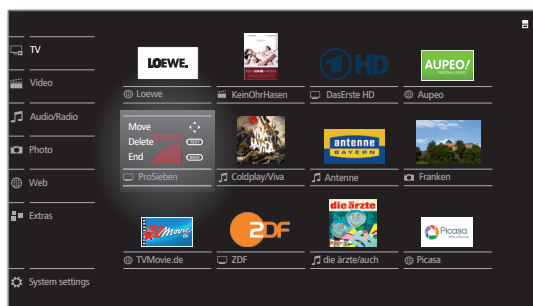

Move favourite or delete it (see below).

### Moving favourites



◀ ▶ ▲ ▼ Move favourite to new position.



**BACK:** Finish procedure.

### Deleting Favourites



**TEXT:** Delete selected favourite.



**BACK:** Finish procedure.

---

## TV

In TV mode that can be selected via the **Home** view, you can use the basic TV functions of your TV set. In TV mode you will have numerous functionalities at your disposal as, for instance, PIP, EPG and, if offered by the station, HbbTV (hybrid broadcast broadband television). By means of the function list (see page 37) you may call additional options and settings all around TV operation.

## Setting the volume

### Switching sound off/on



Sound off.  
 Sound on: Press key again or increase the volume using **V+**.

### Setting the volume

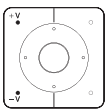

**V+ / V-** Volume up/down.

The volume control bar will be displayed in the upper right corner.

**i** The volume control bar can be deactivated in the menu (see page 104).

## Select station

### Select station with P+ / P-

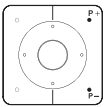

**P+ / P-** Station up/down.

The number and the name of the station along with the title of the programme and that of the next programme will be briefly shown. Also, the status display with time and programme-dependent symbols appears.

**i** The symbols of the status display are described on page 36.

### Select station using the numerical keys



#### 1-digit stations

Press the **numerical key** a little bit longer: The channel will change immediately.

Or:

Press the **numerical key** briefly, the station changes after 2 seconds (changes immediately in case up to 9 stations are stored).



short short long

#### 2-digit and 3-digit stations

Press first (and second) **numerical key** briefly.

Keep the last **numerical key** pressed a little bit longer: The channel will change immediately.

Or:

Press all the **numerical keys** and the channel changes two seconds after the last number was entered (with up to 99 or 999 saved channels it will change immediately).



all short

#### 4-digit stations

Press all four **numerical keys** briefly, the station changes immediately.

**i** If you select an unoccupied station slot, the next available station is switched to.

## Selecting a station out of the station list

**i** In normal TV mode, without other displays:



**OK** call station list.



**OK** The marked station will be called.

## Length of the station list

There is a possibility to influence the amount of stations by using different station lists.

**i** In normal TV mode, without other displays:



**OK** call station list.  
 Call overview of station lists.



**OK** Mark the desired list.  
 The station list will be changed according to the available options. The list will be adopted automatically.  
 Move to the new selected list.

## Explanations of the station lists:

**i** The number and the names of the possible station lists depend on the available signal sources (antennas, TV reception networks, etc.).

Overall station list Stations (channels) from all available sources are indicated in the station list.

AV Exclusively AV inputs are shown in the station list.

DVB-C Only stations from the selected source / reception network are indicated in the station list.

Personal list Only stations of the selected personal list are indicated in the station list. The name of the list may be changed (see page 96).

New personal list Here, you can create a new personal list (see page 96). A maximum of 6 personal lists is possible. The selection must be confirmed with **OK**.

## Selecting stations by means of the expanded station list

**i** In normal TV mode, without other displays:



Press **OK** longer: Call expanded station list.

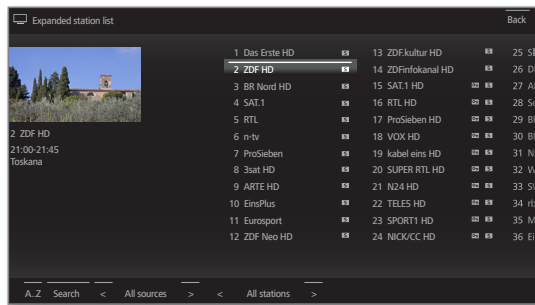

▲▼◀▶ Mark stations.  
◀▶ Scrolling in the station list is possible.  
**OK** The marked station will be called.

Or:



For numerical sorting: Input the channel number. The marker will switch to the selected station. The marked station is shown as a thumbnail picture.



**OK** The marked station will be called.



For alphabetical sorting: Input the first letter (initial, see also page 17). The first station for the specified letters is marked.



▲▼◀▶ Mark the station.  
**OK** The marked station will be called.

## Filter and sort options of the expanded station list

Using the on-screen buttons on the bottom line of the expanded station list you can filter and sort the station list by various combinations of options.

0..9 Numerical sorting of the station list.

A..Z Alphabetical sorting of the station list.

Searching This allows you to do targeted searches for stations. The station name is to be entered via the on-screen keyboard. Entry is described under **General information on menu operation** (see page 17).

Station lists Select the station list, the stations of which are to be displayed in the extended station list (e.g., Personal station list, DVB-C, overall station list).

All stations Here you can specify if **all stations**, only **HD** stations, **locked** stations, **scrambled** stations, **unscrambled** stations, **CI+ protected** stations, **newly found** stations or stations **no more to be found** from the selected sources shall be indicated.

## Selecting stations by personal lists

You can save your preferred stations in up to six personal lists (e.g., for several users). Each personal list can contain up to 99 stations.

How to create and update a new personal list is described on page 96.



**i** Personal list existing.

**i** In normal TV mode, without other displays:



**OK** call station list.  
◀ Open overview of station lists.



▼▲ Mark the desired personal list.  
The station list will be changed according to the available options. The list will be adopted automatically.  
▶ Move to the new selected list.

▲▼ Mark the station.  
**OK** The marked station will be called. Or:



Select station directly with numerical keys.

## Explanation of the icons following station names:

- T** DVB-T station (digital terrestrial via antenna)
- C** DVB-C station (digital via cable)
- S** DVB-S station (digital via satellite)
- CI+** Coded station
- CI+** CI Plus coded station
- 🔒** Locked station (see Parental lock on page 100)

## Status display

**i** In normal TV mode, without other displays.



**INFO:** Show status display.



In the left upper corner you will see in the marked field the number and name of the station, the transmission time and (if available) the title of the current programme. The bar (if available) indicates the progress of the current programme. If information about the current programme is available, this can be called by pressing the **INFO key** again.

In another adjacent field to the right, the programme info of the following programme is displayed additionally for DVB stations.

The field in the upper right corner contains the time, the date and, depending on the DVB station and according to availability, various additional information which is represented by symbols (see column on the right).

The status bar is shown automatically every time you change channels.

The status bar is hidden automatically at the end of the display time.

If you want to hide the status bar manually before the display time ends, you can do this with the **BACK key**.

### Explanations of the symbols in the status display:

General symbols:

- Language/sound selection available
- Subtitles available
- Channel selection for multi-channel providers
- 3D programme
- HDTV programme
- HbbTV mode available from this station

### Explanations of the symbols in the status display (cont'd):

Transmitted audio signal:

- Mono Mono audio transmission analogue
- Dual channel Dual channel sound transmission (Sound1/Sound2) analogue
- 1+1 Dual channel sound transmission (Sound1/Sound2) digital
- Stereo Stereo sound transmission analogue
- Stereo (AAC+) Stereo sound transmission (HEAAC)
- Stereo digital (PCM) Stereo sound transmission digital (PCM)
- Digital Dolby digital sound transmission (DD)
- Digital+ Dolby digital sound transmission (DD+)
- Digital (AAC+) Dolby digital AAC+ sound transmission (HEAAC)
- dts dts sound transmission
- MPEG MPEG sound transmission
- PLII Dolby Pro Logic II sound transmission
- VS Ref Dolby Virtual Speaker Reference display
- VS Wide Dolby Virtual Speaker Wide

Transmitted audio channels:

- DD / dts 1.0 / mono
- DD / dts / MPEG 2.0
- DD / dts 3.0
- DD / dts 4.0
- DD / dts 5.0
- DD / dts 2.1
- DD / dts 3.1
- DD / dts 4.1
- DD / dts 5.1

Selected listening mode:

- 1 Play centre sound or mono (left/right)
- 2 Play front sound (L/R stereo)
- 3 Play front and centre sound
- 4 Play front and surround sound
- 5 Play front, surround and centre sound
- TV Playback of sound via TV speakers
- External speakers Playback of sound via speakers connected to an external amplifier

**i** If the number of speakers appears in brackets, the sound of missing speakers is transmitted by the existing speakers (virtually). The Dolby Virtual speaker (VS mode) developed by Dolby is activated for the virtual sound reproduction.

## Function list

The function list contains settings and additional options. The individual list items will be briefly explained as follows:

**i** The function list can be opened directly in TV mode or via the station list. Depending on this, some list items may possibly not be available.

In TV mode:



**MENU:** Call function list.

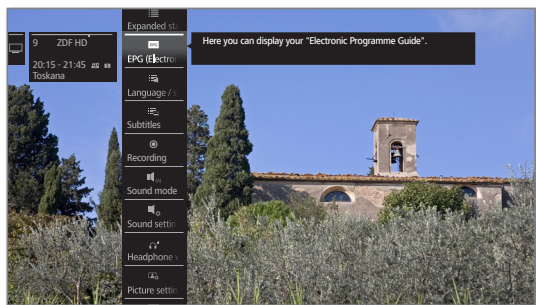

Or:



**OK** Call station list,  
 ▶ call function list.

▲ ▼ Mark function,  
**OK** call.

### Explanations of the symbols in the function list (continued):



Call up **Rotate TV** (see page 42).

**i** Menu item will only be indicated when a motorized stand is connected to the TV set.



Move picture vertically up/down (see page 86).



Add current station as **Favourite** to **Home** view.



Changes the **Sorting** between numerically and alphabetically.



Call up **Edit station list** (see starting from page 95).

Delete stations, shift stations, restore deleted stations.

### Explanations of the symbols in the function list:

Open **Expanded station list** (see also page 35).

Call **EPG (Electronic Programme Guide)** wizard (see page 40).

**i** Menu item is only displayed as long as the EPG wizard has not yet been executed.

Call up **Language / sound**. The sound formats on offer and their designations depend on the programme being broadcast.

**i** Menu item will only be indicated when other languages/sound tracks are available.

Call up selection of **Subtitles**.

**i** Menu item will only be indicated when subtitles are available.

Call **Channel / Video** selection (channel selection of multi-channel providers).

**i** Menu item will only be indicated when several channels/video tracks are available.

Open recording dialogue to programme a **Recording** (see page 78).

Set **Sound mode** (number of speakers) (see page 90).

Call up **Sound settings** (see page 90).

Call up and adjust **Headphone volume**.

**i** Menu item will only be indicated when a headphone is connected to the TV set.

Call up **Picture settings** (see page 86).

Activate **PIP** (picture in picture) (see page 44).

## Electronic Programme Guide – EPG

EPG stands for Electronic Programme Guide and provides you with on-screen programme details. With the system, as with a printed programme guide, you can learn about the current programme. In addition programmes can be sorted according to certain topics, memorised, and also recordings can be programmed.

**i** If a personal list has been selected, only the programmes of stations from the personal list are displayed in the programme list.

### Starting and ending EPG

EPG

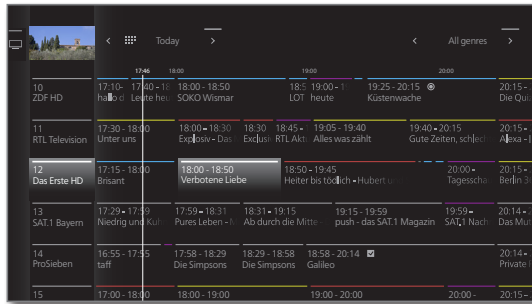

**EPG:** Switch EPG on / off.



- i** EPG is only available for DVB stations.
- i** The first time you start EPG, a wizard will start that guides you through the necessary presettings (see page 40).
- i** Depending on the number of stations selected for EPG, it may take some time until the programme information is displayed.

### Meaning of the colours in the EPG

The coloured labels indicate the genre of the respective programme. When filtering with genre selection in the header, the programmes of the selected genre will be highlighted.

	Movies
	News
	Show
	Sports
	Child
	Music
	Arts
	Social
	Education
	Hobby
	Series

### EPG operation

In the left column there is a list of stations of your currently active station list (personal list, whole station list). With the on-screen buttons in the header of the EPG you can select the day of the programme preview and filter the programmes as to their genre.

When calling up the EPG the main focus is on the selection of the date in the header.



- ▼ go to station list.
- ▼ ▲ Scrolling in the station list.
- ◀ ▶ Scrolling through the programmes.



**RECORD key:** Schedule the recording of the marked programme for a time (see page 39).



**MENU:** Go to header.



- ◀ ▶ Mark selection of date or genre.
- OK** Accept changes.



**MENU:** Move from date to genre or from genre to station list.

### Adapting the EPG Overview

**i** The options to be selected are in the header, if not, press **MENU key**.



- ◀ ▶ Select day or genre.
- OK** Confirm selection.

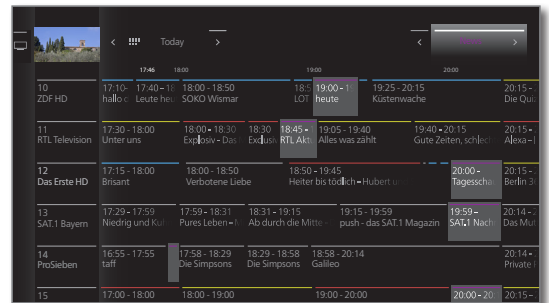

Example If you look for the next newscast select and **news** under genre. Newscasts will be highlighted.



## Calling additional information about the programmes



**INFO:** Call up detailed information.

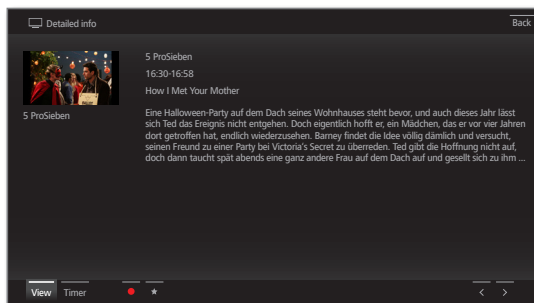

If there is more information on the selected programme, it will be indicated here. You find further information on the indicated programme in the bottom line:

**View** **i** The menu item is only available when the selected programme is on the air. Watch selected TV programme.

**Memorise** **i** This menu item is only available when the selected programme has not started yet. Memorise the programme for later watching / listening. For further information see column on the right.

**i** Depending on the presetting (see page 105) the TV set will switch on by itself when it is in standby.

**Delete memo** For programmes being memorised you can also delete the memo.

**Timer** Call up the overview of the Timer Services (see page 77).

**(Recording)** **●** Schedule the recording of the selected programme for a time (see column on the right).

**(Favourite)** **★** Schedule the recording of the selected programme for a time. Additionally, an entry to the **Home** favourites will be added.

Explanation of the symbols in the programme information:

- Programme in 16:9 picture format
- Programme in high picture definition (HDTV)
- Programme with Dolby-Digital sound
- Transmission of subtitles for hearing-impaired persons
- Programme with Parental lock (see **Parental lock - Age-related lock** on page 100)

The symbols may also appear in combinations.

## Timer programming by means of EPG

You can programme timer recordings of TV programmes conveniently using the EPG.



Mark the desired broadcast.

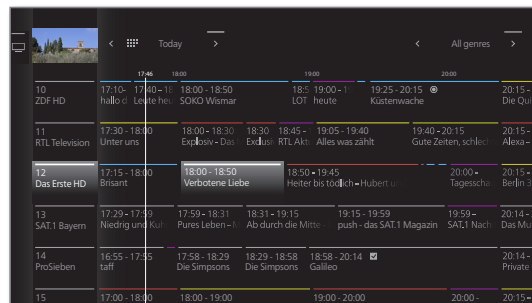

**RECORD key:** Programme timer recording for the TV programme.

Timer data dialogue is opened.

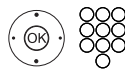
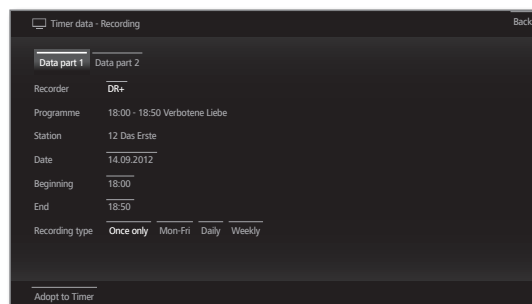

Check the timer data and update it if necessary.

See page 80 for explanations of the setting options in the **Timer data** menu.

**i** In the EPG a recording symbol **●** is placed behind the title of the programme.

## Memorising a programme via the EPG

A programme that has not started yet can be memorised. For memorised programmes, the TV set will ask at the beginning of a programme if it should change the channel accordingly or switch on from the standby mode if this is activated in the **System settings → Control... → more... → EPG** menu (see page 105).



Mark the desired programme.



**INFO:** Call up detailed information.



**Memorise, OK** Memorise programme.

**i** In the EPG a memorise symbol **☑** is placed behind the title of the programme.

**i** The memo of programmes can also be started via the timer instructions (see page 77).



## EPG wizard

In this dialogue you decide, for which station EPG data should be collected and displayed. With the number of stations the time for nocturnal data acquisition will increase. We recommend, also for reasons of distinctness to select only those stations, which you receive regularly.

When the EPG is started for the first time:



▶▶ Continue in the wizard and call up the EPG Station selection.



◀ ▶ ▲ ▼ Mark the the single station,  
**OK** Select / deselect station for EPG.

For display in the EPG, the selected stations are marked with a check mark .

Or:



◀ ▶ ▲ ▼ select **Mark all**.  
**OK** All stations of the station list will be activated for EPG.

Or:



◀ ▶ ▲ ▼ select **Unmark all**.  
**OK** deselect all stations for EPG.

## Configuring EPG

You can find the EPG settings in the **system settings** (see page 105).

---

## Teletext

Your TV set supports the FLOF operating system.  
 Up to 2000 pages are stored so that you have quick access.

### Starting and ending Teletext



**TEXT:** Call teletext.

The function of the **TEXT** key can be set (see page 109). The factory default is **Standard teletext first**.



**TEXT:** Switching between Standard Teletext and MediaText.



Pressing the **BACK** key ends Teletext.

### Key functions for Standard Teletext operation



**0 AV:** Stop self changing pages.



**9:** Zoom in the page (press several times).



**★:** Add active Teletext page to **Home** favourites.

### Page selection with the coloured keys



**Red key:** One page back or back to previous page (depending on Teletext provider).

**Green key:** advance one page.

**Yellow key:** To next topic.

**Blue key:** To next range of topics.

The coloured text (with FLOF) in the last but one line shows you with which coloured keys you can scroll to which topics and ranges of topics.

### Additional page selection possibilities



#### First possibility:

**INFO:** Call **overview page 100**.



#### Second possibility:

Directly enter the page number.

#### Third possibility:

**1** The page includes 3-digit page numbers.

▼ ▲ Mark desired page number.



**OK** Call page.

#### Fourth possibility:

**1** The page consists of several sub-pages, indicated by the symbol and the arrows in the bottom line.

▼ ▲ Go to bottom line.

◀ ▶ Mark < or >.

**OK** select previous / next sub-page.

**1** The number of the current sub-page is shown between the arrows.



### Explanation of the symbols in the Teletext bottom line

Symbol (icon)	Remote control key	Description
<	-	For Teletext pages with sub-pages: Show previous sub-page.
>	-	For Teletext pages with sub-pages: Show next sub-page.
⏏	-	Hide TV picture (Teletext as full screen).
⏏	-	Insert TV picture (Split screen Teletext/ TV Picture).
☰	-	Activate Newsflash mode.
☰	-	Show hidden information on the Teletext page.
☰	-	Hide information on the Teletext page again.
★	★	Add current Teletext page to the favourites in <b>Home</b> view.
⚙	MENU	Call function list with Teletext settings.

## Newsflash

Some text pages, e.g., live tickers, will be permanently updated. In order to keep track of changes and also to be able to watch the TV programme at the same time you may hide the Teletext temporarily and can still remain informed on updates of the page.



◀ ▶ ▲ ▼ Mark  **Newsflash**, confirm with **OK**.

The future behaviour of the News function depends on the type of the Teletext page:

In case of Full screen Teletext pages the Teletext will be hidden. In the upper left corner, there will be a symbol for the activated news function. A screen message appears when the contents of the page has changed:



Show updated page,  
◀ ▶ **yes** or **no**.  
**OK** Confirm selection.

In case of Teletext pages which cover only a part of the Teletext page, e.g., News tickers, the respective part will be faded in and permanently updated.

## End News function



**OK** show Teletext again.

Or:



**BACK:** exit Teletext.

## Rotate TV

By using a connected motorized stand you have the possibility to rotate your TV set by means of the remote control.

**i** How to control the range of rotation and to set the switch off position, you will find on page 111.

### Rotating the TV set

**i** In normal TV mode, without other displays:



◀ ▶ Rotate TV set to the desired position.

Or:

**i** Rotate TV was called up in the function list.

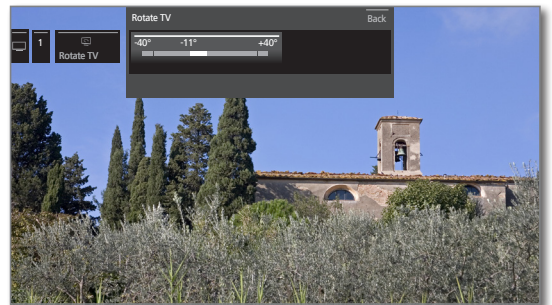

◀ ▶ Rotate TV set to the desired position.

**i** The TV set may be positioned within the set range of rotation.



**BACK:** Exit Rotate TV.

## HbbTV / MediaText

HbbTV<sup>1</sup> (Hybrid broadcast broadband television) offers the user comprehensive multimedia contents, e.g., media centres or additional information on the current programme as far as they are provided by the station.

**MediaText** helps you to use the next generation of teletext/videotext for HbbTV.

MediaText/HbbTV text can either be started directly or through an HbbTV application.

- i** The TV must be connected to the Internet to use HbbTV/MediaText. A connection speed of at least 6,000 kbit/s (DSL 6000 or equivalent) is recommended for smooth playback of videos.

### Open HbbTV application

If an HbbTV application is available for the chosen channel after changing channels, this will be loaded during the automatic start process (see page 108) and a red key symbol will appear. When starting manually, the application will only be loaded by pressing the red key.

- i** HbbTV is offered by the selected channel.
- i** Connection to the Internet established.
- i** HbbTV mode is set to **on**.

 **Red key:** Load / display HbbTV application.



The appearance, key assignment and available functions of the HbbTV applications are dependent on the provider.

Under certain circumstances, the recording and bookmarking functions of the applications may not be supported.

Loewe do not guarantee the accessibility, functionality or content of HbbTV applications.

### Hide / Close HbbTV application



**BACK:** Hide / Close HbbTV application.

Depending on the start behaviour set (see page 108), the HbbTV application will be hidden (automatically) or closed (manually). In the start behaviour **Automatic**, you need to press the **BACK key** a second time for closure. You will see a screen message after closing.

### Open HbbTV text directly

- i** Depending on the programme provider, the direct Call of MediaText may not be possible. MediaText must then be opened by means of the HbbTV application.

- i** MediaText/HbbTV text is offered by the selected channel.

- i** Connection to the Internet established.



**TEXT:** Call up "standard" Teletext (see page 41).

By pressing the **TEXT key** a second time the MediaText/HbbTV-Text will be called up.

- i** The function of the **TEXT key** can be set (see page 109).



Navigation within the HbbTV text and how the coloured buttons are assigned can vary depending on the provider.

### Exiting HbbTV-Text



Pressing the **BACK key** ends HbbTV text.

<sup>1</sup> Depending on the settings selected.

## Picture in Picture (PIP)

The concurrent display of two different images is referred to as Picture in Picture.

The size of the PIP display and the position of the PIP On-screen displays can be changed in the system settings.

Simultaneous display of...	● (yes) / – (no)
a digitally broadcast channel (DVB-T/C/S) and picture from an AV source (e.g., AV, HDMI1)	●
a channel via digital satellite (DVB-S) and a channel via analogue cable television	●
a digitally broadcast channel DVB-T/C and a channel over analogue cable television	●
a digitally broadcast channel over DVB-T/C and a satellite broadcaster (DVB-S)	●
two channels over analogue cable television	–
two digitally broadcast channels (DVB-T/C/S)	●
a free-to-air and an encrypted digitally broadcast channel (DVB-T/C/S)	●
two encrypted channels	●
an SDTV channel and an HDTV channel (DVB-C/S)	●
two HDTV channels (DVB-C/S)	●

- i** Picture change and station selection are restricted during recording.
- i** PIP Mode is not accessible as long as an HbbTV application is active (see page 43).

### Starting and ending PIP mode



**PIP:** Show/hide PIP display.



### The frame is green, if not, press the green button

- i** The frame is green, if not, press **green key**.  
Select the station as usual.



### Select the station for the main picture

- i** The frame is white, if not, press **green key**.  
Select the station as usual.

### Coloured button functions

- i** The frame is green, if not, press **green key**.

**Yellow key:** Swaps contents of TV picture and PIP picture.

**Blue key:** Start/stop PIP scan in the PIP picture.

## Digital-Recorder – Overview of functions

You can record programmes on the integrated hard disk of your TV set with the digital recorder of your Loewe TV set. The various ways in which your Digital Recorder can be used are listed below.



Digital Recorder function	Digital Recorder DR+	see page
Delay TV in live play mode (timeshift)	●	46
Archive recording on the integrated hard disk	●	47
Archive recording on the USB storage device (external hard disk)	–	
Recording / Time delay with digital stations (DVB-C/-T/-S)	●	47, 46
Recording / Time delay with analogue stations	–	
View other channels whilst the archive recording is taking place	●	48
Subsequent archive recording	●	47
Delay TV when archive recording is running	●	48
View other channels with delay TV whilst the archive recording is taking place	●	48
Archive playback from DR+	●	49
Archive playback from USB storage devices (external hard disk)	●	49
Copy recorded programmes from DR+ onto a USB storage device	●	51
Copy recorded programmes onto an external recorder	–	
Copy recorded programmes from one USB storage device to another	●	51
Permit recorded programmes to be viewed on the network	●	106
View programmes that have been permitted to be viewed over the network	●	53
Set/delete manual bookmarks	●	61
Hide parts of a recording	●	61, 62

- possible
- not possible

## TV viewing with time shift

The TV broadcast that you watch is automatically recorded in the background. You can stop the TV programme at any time and continue watching it later with a time shift. The maximum time shift is three hours. The recording starts again from the beginning and the old content is deleted every time you switch stations.

- i** Recording of analogue stations is not possible.
- i** Time-shifted operation is perhaps not possible or only to a limited extent for programmes of stations working with CI Plus encryption (see page 82).

### Interrupt watching (start timeshift television)



Press **PAUSE key**.

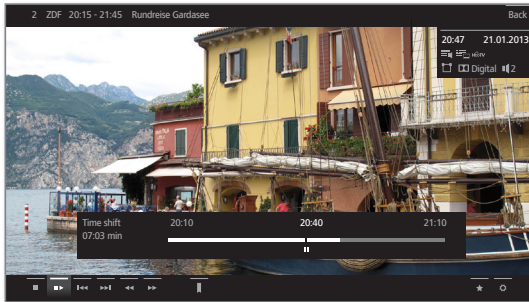

The TV image becomes a freeze frame and the DR status display appears.

At the top you will see the number and name of the station if EPG or Teletext data is available, in addition to the start and end of the current programme and the title of the programme.

In the lower part of the screen you find the starting time of the background recording left of the time bar. On the right hand side of the bar you can see the time at which the time shift recorder will be full (automatically extends by 30 minutes, up to a max. 3 hours). The time above the bar at the PAUSE key shows the current time.

### Continue (time shift viewing)



Press **PLAY key**.

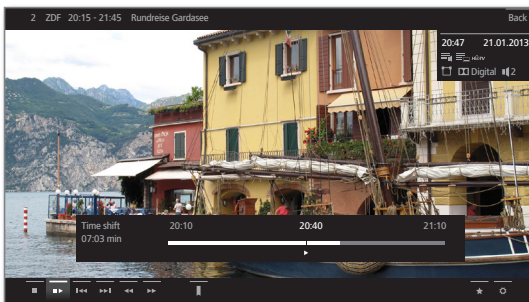

You can now continue watching the TV programme at the time when you had pressed the **PAUSE key**. The Playback symbol **▶** appears instead of the Pause symbol **||**.

For further options of time-shift watching see starting from page 56.

### Returning to live picture (end timeshift television)



Press **STOP key**.

You see the station's live picture again.

### Switch to a different station

If you switch the channel, the time-delayed recording (time shift) is restarted. The current time-delayed recording is discarded (time shift buffer is emptied).

### Setting bookmarks

You can manually set bookmarks during time-shift TV watching. For this, the time shift recording is converted into an archive recording. You will find further information on page 61.



## Archive recording

- i** Recording of analogue stations is not possible.
- i** Recordings of CI Plus encrypted programmes are perhaps not possible or only to a limited extent (see page 82).

Films that you wish to watch at a later date can be recorded in the Digital Recorder Archive (DR+ archive).

If EPG or teletext data is available, the Digital Recorder stores the title and additional information on each programme in the archive.

If additional languages are being transmitted for a DVB broadcast, these are also recorded. DVB subtitles or Teletext subtitles can also be recorded. Language selection and subtitles are displayed as in TV mode.

You can watch another programme or playback a recorded TV programme from the archive while recording a TV programme into the archive. You can also play back the programme that you are just recording or any other programme with time delay.

During the archive recording, the bar showing the recording progress is red.

### Direct Recording and One Touch Recording

Record interesting programmes directly into the DR+ archive by pressing the **RECORD key**. When watching time-shift broadcasts the current broadcast can be saved to the DR+ archive.

### Subsequent archive recording

You can also save an already viewed and finished broadcast in the archive provided there has been no change of station in between. Skip or wind back to the desired broadcast and start the recording.

### Time shift viewing with archive recording

Whilst an archive recording is taking place you can play back the programme that is being recorded or watch a programme on another channel using time delay.

For further options of time-shift watching see starting from page 56.

### Direct recording



Press the **RECORD key** for a short period: Start direct recording.

Recording dialogue for the current broadcast is called.



◀ ▶ Select recording time,  
**OK** Start recording.

### One Touch Recording

With One Touch Recording, the recording starts immediately at the press of a button.



Press **RECORD key** longer: Start One Touch Recording.



◀ ▶ Select recording time,  
confirm with **OK**.

### Additional information on direct recording and one touch recording

- i** If the broadcast was watched right from its start, it will be saved from the beginning in the DR+ archive. Otherwise, recording begins at the point from which viewing of the broadcast began.

### Timer-controlled recording

Comfortably select your favourite programme for recording from the EPG. The timer overview has room for 50 entries.

You will find further information on timer-recording starting from page 78.

## Setting bookmarks during archive recording

During a running archive recording you can create bookmarks (by pressing the **PLAY key** a little longer). You will see a message on the screen. Bookmarks also serve as starting and end points of intervals.

## Time shift viewing during archive recording



**PAUSE key:** Switch to freeze picture. The recording is continued in the background.

Display during time-shift viewing and archive recording:

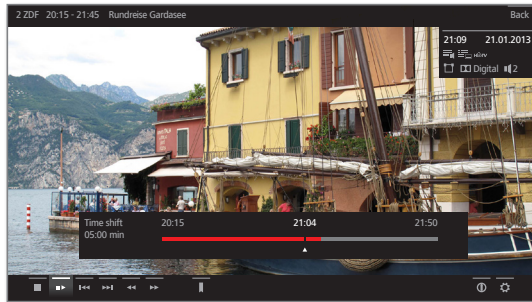

**PLAY key:** Continue playback. You will now see the time-shift archive recording.

For further options of time-shift watching see starting from page 56.



**STOP key:** End time shift and return to the live picture of the current archive recording.

## Watching other stations during archive recording

After you have started the recording, you can switch to another station.

**i** The second channel can be watched in time-shift TV whilst a recording is taking place (Timeshift during archive recording).

## Viewing another programme from the archive during archive recording

After you have started the recording, you can also watch a programme you have already recorded.



Open the **DR+ archive**.



▼ ▲ Mark the recorded programme. **OK** view programme.

The recording process is continued in the background.

## Switching off the TV set during recording

You can switch off the TV to standby whilst recording. The recording is continued in the standby mode.

**i** **Never** switch the TV set off at the mains and do **not** pull out the plug of the TV set out of the socket. Otherwise the recording will be lost!

## Subtitles

Subtitles of a broadcast can also be stored during recording (see Timer data on page 80).

**i** The recording of subtitles in DR+ continuous mode must be activated in the settings (see page 106).

Calling up the subtitles during a later playback is similar to calling subtitles in TV mode (see page 37).

## Stop recording early

You can end a current archive recording prematurely.



Press **STOP key**.

A message appears in the right upper corner of the screen.



**OK** Stop recording.

The recording process is ended. The portion of the TV broadcast recorded up to this point is saved on the hard disk and can be played back via the DR+ archive.

**i** You can also end a running recording by deleting the corresponding timer entry in the timer overview. See page 79 for further information.

## DR+ archive

With the DR+ archive you have access to all the recorded programmes and start playback.

An automatic Delete Manager always ensures that there is sufficient recording space for new movies (see page 51).

### Open the DR+ archive



Open the **DR+ archive**.



▼ ▲ Select desired archive,  
**OK** Display archive entries.

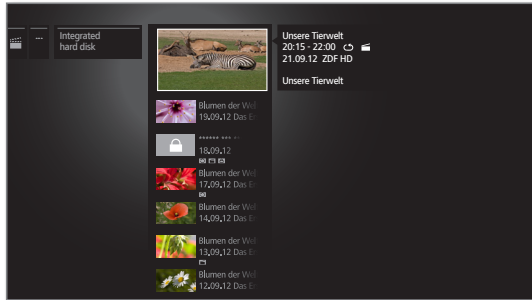

### Selecting the recorded programme



▼ ▲ Mark the recorded programme.  
▶ Call function list.

### Explanation of broadcast information

The progress bar in the upper part of the broadcast information shows you how much of the recording has already been watched. Further information on the recording, as far as available, can be called via the function list (see column on the right).



Archive entry with set parental lock (page 52)



Archive entry with set Delete protection (page 51)



Archive entry with active playback (page 59)

### DR+ archive function list

The function list of the DR+ archive contains the individual function for its archive entries.



▶ Open function list for marked archive entry.

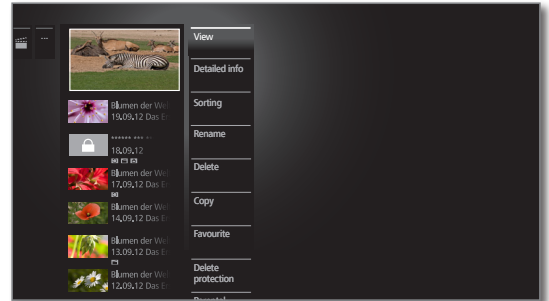

- View** Start or continue replaying the selected archive entry. See page 56 for further information.
- Detailed info** Show detailed information on the marked archive entry. See page 50 for further information.
- Sorting** Sort archive entries in alphabetical (ascending A-Z or descending Z-A) order or according to recording date (newest entries first).
- Rename** Change title of archive entry. See page 50 for further information.
- Delete** Delete archive entry from hard disk and recover disk space. See page 50 for further information.
- Copy** Copying an archive entry to an external hard disk. See page 51 for further information.
- Favourite** Add archive entry to **Home** favourites. See page 33 for further information.
- Delete protection** Activate or deactivate protection against automatic deletion by the Delete Manager. See page 51 for further information.
- Parental lock** Protect recorded broadcast by a four digit PIN against unauthorised playback.  
**i** This menu item appears only when a PIN has already been defined (see page 100).
- Repeat** Play archive entry repeatedly (in a loop) when the archive entry is replayed in the future. See page 59 for further information.
- Rotate TV <sup>1</sup>** Rotating the TV set. See page 42 for further information.
- Settings** opens the video settings. Further information you find starting from page 85.

<sup>1</sup> Menu item will only be indicated when a motorized stand is connected to the TV set.

### Displaying detailed information on the recording

If detailed information exists on the recorded broadcast from the EPG, you can display it.

**i** The desired entry in the DR+ archive is marked.



▶ Call function list.

▼ ▲ Mark **Detailed info**.

**OK** Display detailed information on the broadcast.



For the explanation of the symbols in the bottom line see page 39 and 57.

### Deleting recordings from the archive

**i** The desired entry in the DR+ archive is marked.



**STOP key:** Call delete dialogue.

Or:



▶ Call function list.

▼ ▲ Mark **Delete**.

**OK** call.

**OK** Confirm deletion. The DR+ archive will be displayed again.

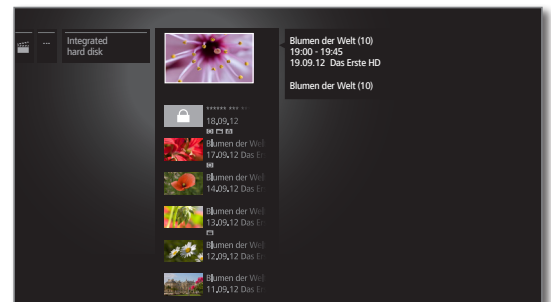

### Changing the title of an archive

**i** The desired entry in the DR+ archive is marked.



▶ Call function list.

▼ ▲ mark **Rename**.

**OK** Call.

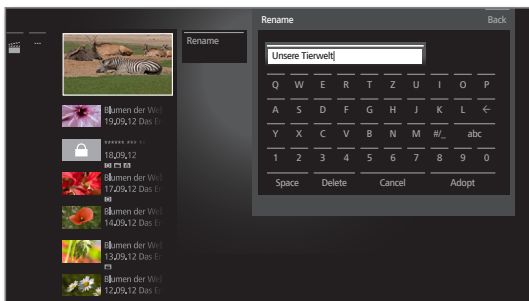

Or:



◀ ▶ Select **no**.

**OK** Cancel procedure and return to function list.

**i** It may take some time to delete recordings from external hard disks, depending on the length of the programme and recording quality. To ensure a correct deletion process, cancel the presence of the external hard disk via MediaHome (see page 55), before unplugging it from the TV set. You will see a screen message as soon as the hard disc can be removed.



◀ ▶ ▲ ▼ Select characters.

**OK** Move character to input line.

**i** For further information on character input see page 17.

End input with **Adopt**. This saves the change permanently.

Or:



**BACK:** Cancel renaming.

## Copying your recordings

You should copy recordings that you want to save permanently on an external USB hard disk.

- i** Copying recordings, which originate from a CI Plus encrypted station, is perhaps not possible or only to a limited extent (see page 82).

## Copying recordings to an external hard disk

You can also copy programmes onto an external hard disk, and archive them or make them available to other Loewe LCD TV sets (even those without DR+).

- i** The desired entry in the DR+ archive is marked.



- ▶ Call function list.

- ▼ ▲ Mark **Copy**.  
**OK** call.

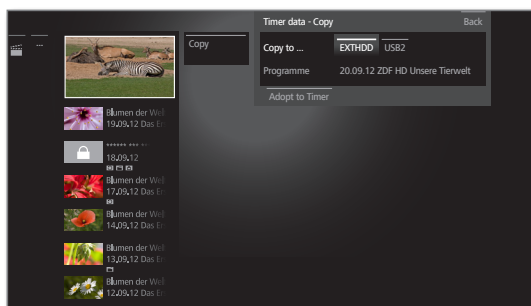

- ◀ ▶ Select target in Timer Data Dialogue.  
**OK** Start the copy procedure.

- i** Copying to an external hard disk takes place in the background and at a significantly higher speed. You see a screen message, when copying has finished.

- i** The status of copying assignments in progress/pending can be seen in the timer instructions.

- i** The TV set must **not** be switched off with the mains switch during the copying process!

## Setting/cancelling delete protection

You can provide films with a delete protection to prevent an automatic deletion by the delete manager (see column on the right).



- i** The desired entry in the DR+ archive is marked.

- ▶ Call function list.

- ▼ ▲ Mark **Delete protection**.  
**OK** Call.

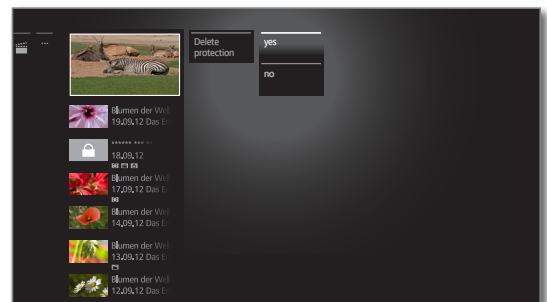

- ▼ ▲ Mark **yes / no**.  
**OK** Adopt settings.

## Delete manager

The Delete Manager always makes sure there is enough memory space on the hard disk for new recordings.

If the capacity on the hard disk is nearly fully exhausted, the oldest recording(s) are automatically deleted in order to create space on the hard disc.

Recordings which have been protected with a delete protection (see page 51) are not deleted by the Delete Manager. However, you can still delete these recordings manually.

To avoid data loss, we recommend copying important recordings to an external USB hard disk.

Delete the recordings from the Digital Recorder after copying.

- i** Loewe are not liable for data loss from the Digital Recorder's hard disk.

## Locking/unlocking a movie (Parental lock)

You can lock movies that your children are not permitted to view, for instance. Playback is then only possible after entering a PIN.

**i** In order to activate the Parental lock, a code number (PIN) must have been defined beforehand. Defining the access code: page 100.

**i** The desired entry in the DR+ archive is marked.



▶ Call function list.

▼ ▲ Mark **Parental lock**,  
**OK** Call.

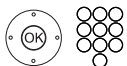
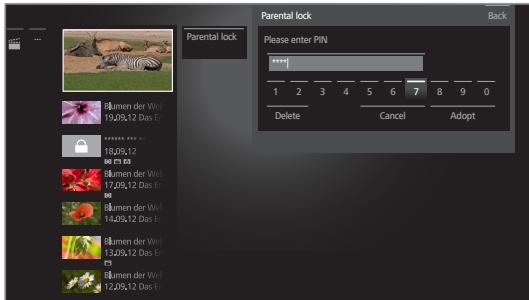

Enter your PIN.

◀ ▶ ◂ ▸ ▲ ▼ Mark **Adopt**,  
**OK** Confirm the access code (PIN).



▼ ▲ Select **Yes / No**,  
**OK** Adopt.

**i** The titles of locked films in the DR+ archive will be replaced by asterisks \* when a parental lock is active and thus cannot be read anymore. The detailed information for the recording cannot be called up. The cover of the recording will be replaced by a picture of a lock. In addition, the entry will be labelled with the symbol

Please also observe the notes on page 100 regarding the parental lock.

## Viewing a locked movie

**i** The desired locked entry in the DR+ archive is marked.

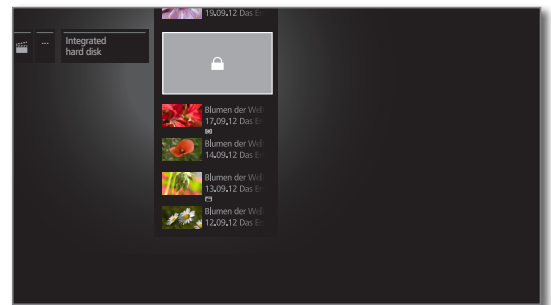

When the access code of the parental lock has not been entered yet:



**OK** call entry of PIN.

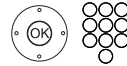

Enter your PIN.

**i** After the access code has been entered, the lock of the archive entries will be temporarily released.



**OK** View film.

## DR+ Streaming

You can release your DR+ archive entries in order to view these on other Loewe TV sets linked to the network.

**i** To use DR+ Streaming, at least two Loewe TV sets with MB180, SL1xx or SL220 chassis are required (at least one of which has DR+ integrated). The TV sets also need to be connected via a wireless connection (WLAN) or a cable connection (e.g. Ethernet, PowerLine).

**i** DR+ Streaming must be enabled in the system settings (see page 106).

**i** Archive entries can only be provided or released in the network by TV sets **with** integrated hard disks (DR+).

Playback of released archive entries is possible on all TV sets with MB180, SL1xx (**with/without** DR+) and SL220 chassis linked to the network.

**i** Functions that would require write access to a released device (parental lock, delete protection, renaming, deleting an entry or bookmark, creating a bookmark, deleting/hiding parts of a recording) are not available during playback of a DR+ archive entry via the network.

### Playback of DR+ archive entry via the network

DR+

Open the **DR+ archive**.



▼ ▲ Select desired archive,  
**OK** Display archive entries.

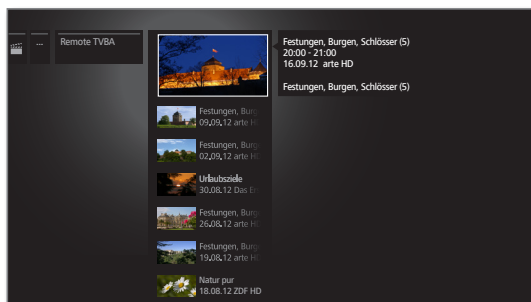

▼ ▲ Mark the required archive entry,  
**OK** View archive entry.

For further information on operation see page 56.



## General information on media reproduction

**Home** view gives you access to photos, videos and music from your personal storage media, e.g., from storage media connected via USB and from media servers in your home network to which your TV set is connected.

The item **Web** gives you access to an Internet browser and multimedia data from the Internet.

Please follow also the information below for the **MediaNet** Internet functions which can be called under **Web**.

### Connecting the TV set to your network

To receive media via media servers in your home network or via the Internet, you have to integrate your TV set in your home network. You can connect your TV set both with a **wired connection** (Ethernet, PowerLine) or via a **wireless radio connection** (WLAN). For wireless connections, the TV set has an internal WLAN antenna. You can find connection examples for both cases on page 13.

Your Loewe TV set supports the UPnP AV standard for data playback in the home network. You can find more detailed information on this in the glossary starting from page 149.

### Help for configuration problems

Loewe cannot provide any support for PC hardware and software or network components owing to the diverse configuration options with home networks.

Please contact the administrator of your home network and/or specialist dealer for support when setting up and for maintenance of network connections, storage media, media server software and network devices, e.g. routers.

### MediaNet

If you wish to use MediaNet we recommend registering your TV set on our homepage.

<http://support.loewe.tv> (International),  
<http://support.loewe.tv/uk> (United Kingdom and Republic of Ireland),

<http://support.loewe.tv/au> (Australia) or  
<http://support.loewe.tv/nz> (New Zealand).

(using the **Register free-of-charge** option).

Simply follow the steps in the registration process.

The MAC address of your TV set is required for the registration. You can find this in the TV set under **Extras** → **Special functions** → **Integrated features** → **MAC address (TV)**.

## Accessing your media

HOME

**HOME:** Call **Home** view.



◀ ▶ ▲ ▼ Mark desired function,  
**OK** call function.

**Video:** see page 55.

**Audio/Radio:** see page 64.

**Photo:** see page 71.

**Web:** see page 74.

### Playing music and videos, displaying images

The windows for playing music and videos and for displaying photos are comparable for all cases irrespective of the media source. The relevant players are therefore grouped together.

### Exit media

HOME

**HOME:** Call **Home** view and select another function (see above).

Or:

TV AUDIO

Press **TV** or **AUDIO** key for TV and radio mode swapping <sup>(1)</sup>.

<sup>(1)</sup> The assignment of the AUDIO key can be changed (see page 133). The description refers to the standard setting.

## Video

The item **Video** gives you access to videos from local (USB, home network) and online sources. The individual subitems are described in detail in the following.

### Calling video selection

HOME

**HOME:** Call **Home** view.



▼ ▲ Mark **Video**,

**OK** call list of video sources.



▼ ▲ Mark function,

**OK** call.

**DR+ archive** Programmes that you have recorded onto the integrated hard disk using the Digital Recorder are compiled in the **DR+ archive**. Via the DR+ archive you can replay, edit or delete your recorded programmes. For further information on the DR+ archive see page 49.

**MediaHome** **MediaHome** includes both storage media directly connected to the TV set (e.g., USB sticks) as well as data provided in your home network (e.g., from a media server on a PC or a network hard drive). For further information on MediaHome see column on the right.

**MediaNet** Call **MediaNet** → **Browse** → **Video** (see page 75).

### Information on high-resolution films in general

Due to technical limitations (e.g., interference, limited bandwidth), interruptions to playback up to and including complete termination of the playback may occur when playing high definition film material (HD films) on 720p format or above (1280 x 720 resolution or above) via the home network.

### Information on high-resolution films via wireless connection

High definition movie material (HD movies) from format 720p upwards (resolution 1280 x 720 or higher) should be played back via a **wired** connection. If there is a **wireless** connection, then technical limitations (e.g., fault liability, bandwidth limitations) can cause disruptions in the playback right up to a complete breakdown of the playback.

## Video – MediaHome

**MediaHome** includes both storage media directly connected to the TV set (e.g., USB sticks) as well as data provided in your home network (e.g., from a media server on a PC or a network hard drive).

### Open MediaHome

HOME

**HOME:** Call **Home** view.



▼ ▲ Mark **Video**,

**OK** call.

▼ ▲ Mark **MediaHome**,

▶ go to next column.

▼ ▲ Mark desired media source,

▶ go to next column.

Open Display content of the media source.

Unmount Unmount USB data storage medium before removing it in order to prevent data loss.

Settings opens the video settings.  
See page 85 for further information.

### Examples of media sources

**TwonkyMedia WMP11** Examples with media servers in your home network. The exact designation depends on the media server used.

**USB** USB storage media on the USB connections of your TV set. The exact designation depends on the relevant storage medium.

**i** Please also observe the notes on page 143 regarding USB sticks!

**i** The media sources shown here depend on the devices available/used.

### Selecting videos



▼ ▲ Mark desired directory,

**OK** open directory.

Repeat procedure if necessary.

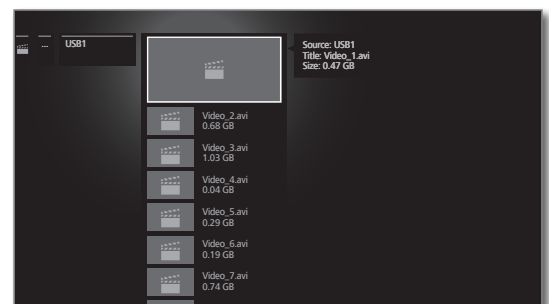

▼ ▲ Mark desired video,  
▶ open video function list.

## Video Function list

The video function list contains the individual functions for your videos.



▶ Open function list for the marked video.



**View** Start or continue playback of the selected video.

**Sorting** Sort videos in alphabetical (ascending A-Z or descending Z-A) order, file size or date (newest entries first).

**Favourite** Add video to the **Home** favourites. See page 33 for further information.

**Rotate TV** Rotating the TV set. See page 42 for further information.

**Settings** opens the video settings. Further information you find starting from page 85.



▼ ▲ Mark desired function,  
**OK** Confirm selection.

## Video playback



### General information on video playback

The description of the following functions applies to the playback of videos from the DR+ archive as well as for videos from USB storage media or from media servers in the home network.

**i** For playback of DR+ archive entries we have additional playback and editing capabilities. The explanation of these functions you find starting from page 61.

### Video status display

The video status bar provides you with further options on the current playback.

















▲ ▼ Show status bar.















For the explanation of the symbols in the bottom line see page 57.



**BACK:** Hide the status display again.

## Description of the symbols in the status display for video playback

Symbol	Remote control key	Description
■		For playback of videos from MediaHome: End playback and return to media overview. For time-shift viewing: End time-shift and return to live picture. For playback from archive: End playback and return to DR+ archive.
⏸		Stop/continue playback.
⏪		Continue halted playback.
⏮		Skip backwards.
⏭		Jump forwards.
⏮		Winding backwards. Selecting again for changing the speed. Available speeds: 2x, 5x, 10x.
⏭		winding forwards. Selecting again for changing the speed. Available speeds: 2x, 5x, 10x.
⏮	 P+ / P-	Select previous / next video.
	-	Change picture format of the video playback.
	-	Rotating the TV set. See page 42 for further information.
hh:mm	-	Skip to desired position in the playback.
	-	<b>i</b> For playback from DR+ archive: Activate / deactivate again the repetition of the currently played archive entry.
	-	
	-	<b>i</b> For playback of videos from USB storage media or from the home network: Switch repetition (loop playback) of all titles of the current directory ON/OFF.
	-	<b>i</b> For playback of videos from USB storage media or from the home network: Switch ON/OFF repetition (loop playback) of the current title.

Symbol	Remote control key	Description
	 long	<b>i</b> Only for playback from DR+ archive: Set bookmark manually. In case of time-shifted viewing the time-shifted recording will be converted into an archive recording.
	 long	<b>i</b> only for playback from DR+ archive: Delete bookmark manually. <b>i</b> The function is only available when a manually set bookmark is within five seconds around the playback position.
		<b>i</b> Only for playback from DR+ archive: Skip to next bookmark.
		<b>i</b> only for playback from DR+ archive: Skip to previous bookmark.
	-	<b>i</b> only for playback from DR+ archive: Call interval functions.
	-	<b>i</b> only for playback from DR+ archive: Call dialogue for deleting bookmarks.
★		Add currently played video to the favourites in Home view.
		Call detailed info on the current playback.
		Call function list with video settings.

## Pause playback (freeze picture)



**PAUSE key:** Switch to freeze picture.

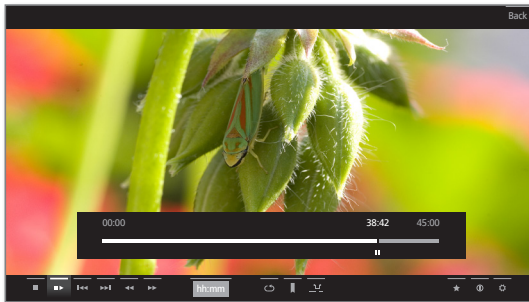

**PLAY key:** Continue playback.

## Jump

By briefly pressing the **◀◀** or **▶▶** keys you can skip forwards and backwards in the movie. The jump distance is adjustable (see page 106).



▶▶ Skip forwards.

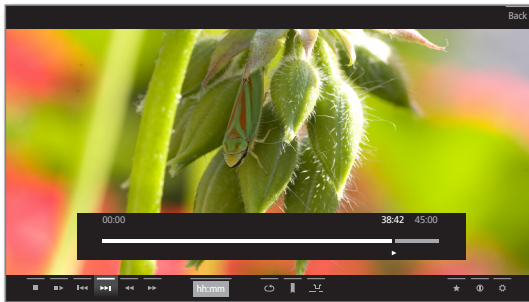

◀◀ Skip backwards.

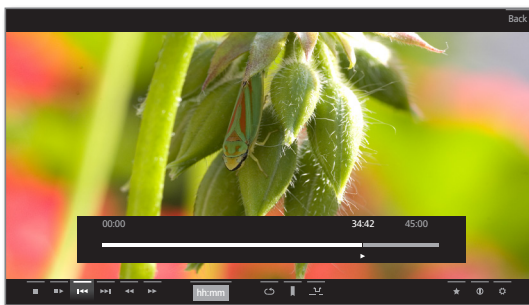

## Skipping with Smart jump

The **Smart jump** function ensures that the jump width is halved each time the jump direction is changed or doubled after three jumps in the same direction (max. 8 minutes). This way you can quickly find a certain spot of the recording.

The settings for Smart jump you find in the **System settings** under **Control** → **more ...** → **DR+** → **Smart jump**.

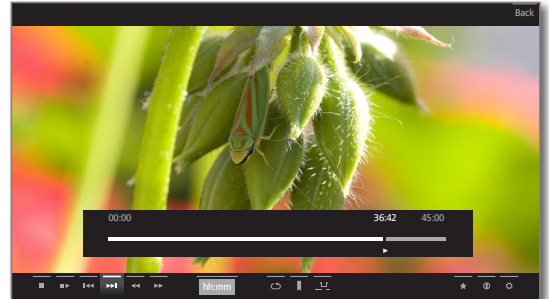

For example, you are searching for the beginning of a broadcast that has already started:



Press **◀◀** repeatedly quickly to jump back.

If you have jumped past the beginning of the programme, jump in the opposite direction:



Press **▶▶**. This jump in the opposite direction is only carried out for half the jump distance. Jump forward using **▶▶**.

If you have jumped past the start of the programme:



◀◀ Jump back again. In the process, the jump distance is cut in half again.

By halving the jump distance when changing direction again you can find your way to a specific position.

## Jump by entering a time

You can jump to any position in the video by entering a time.



▲ ▼ Show status bar.

▼ ▲ ◀ ▶ mark **hh:mm** (**Jump to ...**).

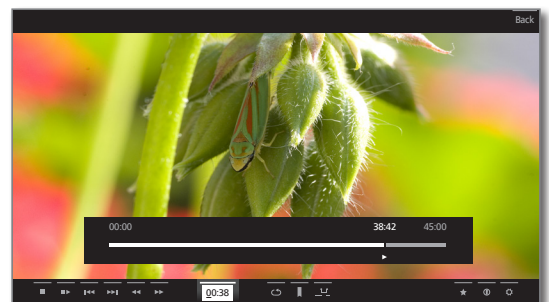

Enter the desired time with the **numerical keys**.





**OK** Execute jump.

## Wind

To search for desired scenes in movies you can fast forward and rewind at three different speeds. Sound is not audible during winding.

  or  or  press a little bit longer.



By each brief pressing of  or  the speed will increase until you switch back to the first speed. Available speeds: 2x, 5x, 10x.

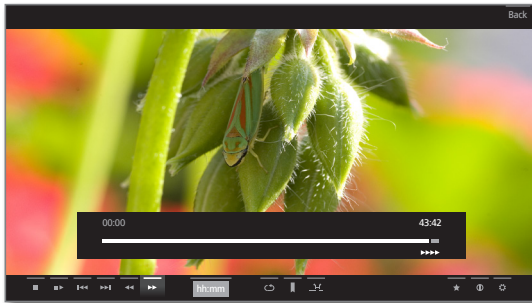

**i** In case of time-shift viewing, playback is automatically activated when the end of the recording is reached. You are then about 10 seconds behind the live picture or when rewinding at the beginning of the time shift recording.

**i** In case of Fast forward of archive entries, playback will finish at the end of the recording. The DR+ archive is displayed again.



**PLAY key:** Continue playback.

**i** In the case of Internet videos, please wait until these are buffered in the memory. This can take a few seconds, depending on the bit rate of the film and Internet speed.

## Repeat

Videos can be repeated, i.e., replayed in an endless loop. Depending on the source (DR+ archive, USB storage medium, media server in the network), single or all videos can be replayed in an endless loop.

### Repeated playback of DR+ archive entries



▲ ▼ Show status bar.



▼ ▲ ◀ ▶ mark **Repeat** , confirm with **OK**.

The current archive entry will be replayed repeatedly. The repetition setting remains active for this archive entry even when the playback is finished.

To deactivate playback again:



▼ ▲ ◀ ▶ mark **Repeat off** , confirm with **OK**.

### Repeating videos from USB storage media or media servers



▲ ▼ Show status bar.



▼ ▲ ◀ ▶ mark **Repeat title** ,

**OK** Switch the repetition of the individual video ON/OFF.

**i** The repeat setting remains until it will be deactivated or another video is replayed.

Or:



▼ ▲ ◀ ▶ mark **Repeat all** ,

**OK** Switch repetition of all titles of the current directory ON/OFF.

**i** The repeat setting remains until it will be deactivated or another directory in the overview is selected.

**i** **Repeat title** and **Repeat all** cannot be activated simultaneously. Using one of the two functions deactivates the respective other one.



## Slow motion

At an active pause (freeze frame) you can select from four slow motion speeds (for wind/rewind). There is no sound during slow motion replay. When viewing HDTV slow motion backwards is not possible.



**PAUSE key:** Switch to freeze picture.



Press **⏩** or **⏪** briefly.

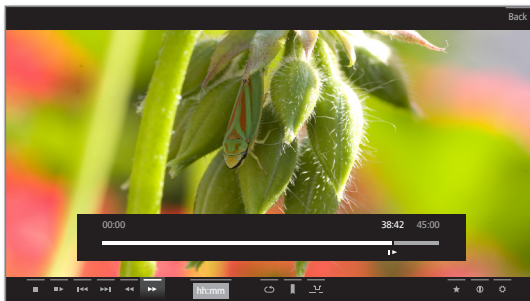

Increase speed:  
Press **⏩** or **⏪** briefly.

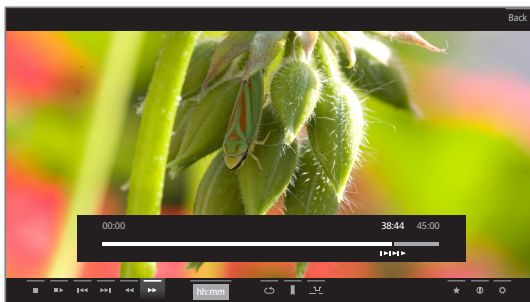

The speed increases every time you press the button until eventually switching back to the initial speed.

## Select language/sound

Videos, especially those recorded from TV broadcasts, can contain several sound tracks. Select sound track/language:



▲ ▼ Show status bar.



▼ ▲ ◀ ▶ Mark **Settings** ,

**OK** Call settings.

▼ ▲ mark **Language/sound**.

**OK** call Language/Sound selection.

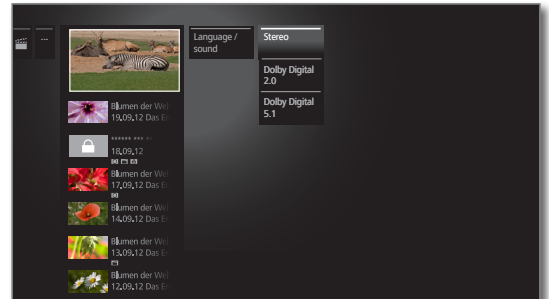

▲ ▼ mark desired sound or desired language,  
**OK** select sound track.

## Changing the picture format



▲ ▼ Show status bar.



▼ ▲ ◀ ▶ Mark **Change Picture format** ,

**OK** set picture format.

You can choose between small or full image settings. Small image setting shows the video close to the original resolution. The video status bar is permanently shown below the image.

The full image setting enlarges the image to fit the entire screen. The status bar can be set to visible or hidden.



## Additional functions for DR+ archive playback

There are additional editing and playback functions for playback of recorded programmes from the DR+ archive. These are explained as follows.

### Setting bookmarks

To retrieve interesting scenes in a movie later, you can manually set the bookmarks. In addition, there are also automatically set bookmarks every time a broadcast is changed. You can jump to each of the bookmarks in succession by pressing a key.

In case of a running time-shift recording (timeshift television), this will be converted into an archive recording when a blank is set.



**PLAY key** (press a little bit longer): Set bookmark.

You will see a message on the screen. The drive display is then faded in and you will see the set bookmark above the bar for the playback.

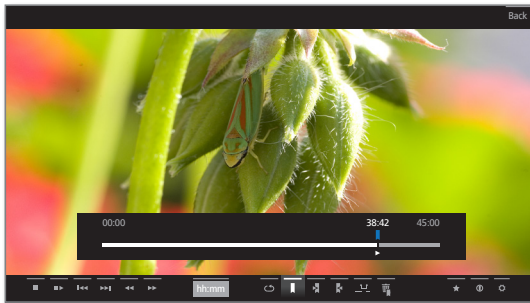

**i** Automatically set bookmarks are white. Manually set bookmarks are blue.

### Interval functions

The intervals between manually or automatically set bookmarks (intervals) can be faded out for future playbacks. In addition to that, unwanted intervals at the beginning or end of your recorded broadcast can be deleted.

**i** An archive entry is replayed.



▲ ▼ Show status bar.

Move to the desired interval in the recorded broadcast by skipping or winding.



**PAUSE:** Stop play.

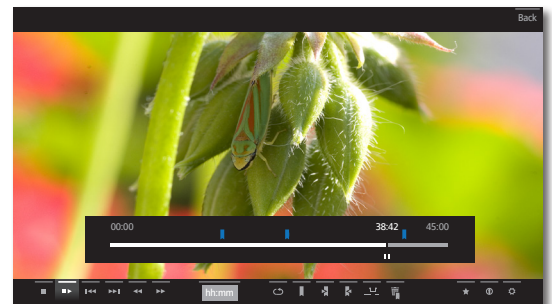

◀ ▶ ▲ ▼ Mark **Interval functions** 1-1.

**OK** Call interval functions.

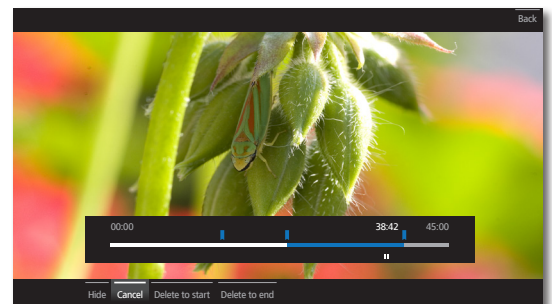

## Hiding intervals

**i** The **Interval functions** are activated (see page 61).



◀ ▶ mark **Hide**.

**OK** hide current interval.

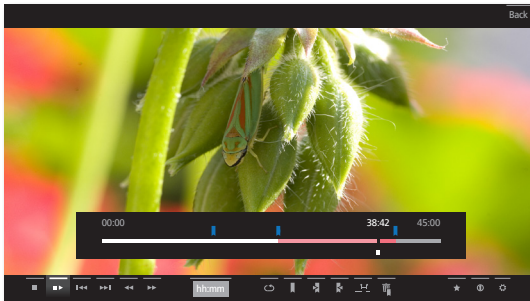

This interval will be skipped when the archive entry is replayed in the future.

## Deleting part of the recording



Press **PAUSE key** at such a position from which the recording shall be deleted up to the beginning or to the end.

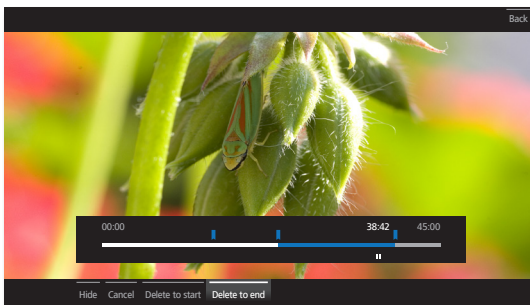

**i** Call Interval functions (see page 61).



◀ ▶ mark **Delete to start** or **Delete to end**, confirm with **OK**.

◀ ▶ mark **Confirm delete**

**OK** Delete part of recording.

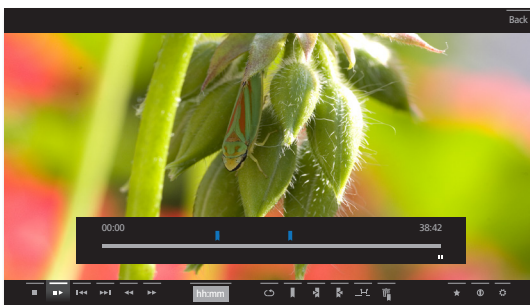

## Deleting intervals

Defined intervals will be deleted when you delete the corresponding bookmark at the beginning or the end of the interval. For Deleting bookmarks see page 63.

## Jump to bookmarks



◀ ▶ ▶ ▲ mark next bookmark ▶

**OK** Jump to next bookmark.



◀ ▶ ▶ ▲ mark previous bookmark ▶

**OK** Jump to next bookmark.

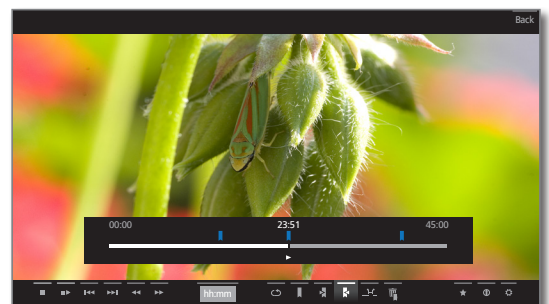

### Deleting individual bookmarks

Jump to the manually set bookmark to be deleted.



Press **PLAY** key for a little bit longer: Delete bookmark.

### Deleting the Bookmark during playback

You can delete your manually set bookmarks during the playback of the DR+ Archive entry.

**i** Manually set bookmarks are blue, automatically set bookmarks are displayed in grey. Automatically set bookmarks cannot be deleted.



**PAUSE** key: Switch to freeze picture.



▼ ▲ ◀ ▶ mark **Delete bookmark**   
**OK** call delete dialogue.

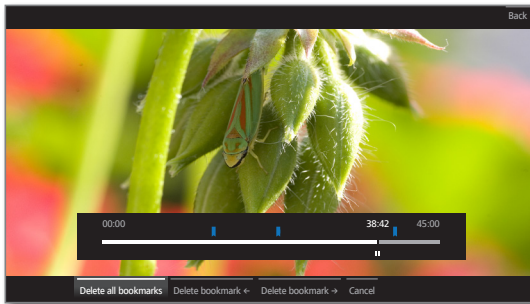

Delete all bookmarks All manually set bookmarks (blue) in the current recording are deleted.

Delete bookmark ← The manually set bookmark to the left of the current position will be deleted.

Delete bookmark → The manually set bookmark to the right of the current position will be deleted.



**OK** Confirm selection.



**PLAY** key: Continue playback.

### Subtitles

Subtitles of a broadcast can also be stored during recording (see Timer data on page 80).

Showing recorded subtitles during playback:



▲ ▼ Show status bar.



▼ ▲ ◀ ▶ mark **Settings**   
**OK** Call settings.

▼ ▲ mark **Subtitles**  
**OK** Call up available subtitles.

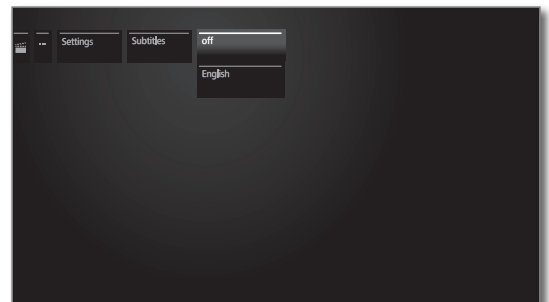

▼ ▲ Mark the desired subtitles,  
**OK** show/hide subtitles.

## Audio/Radio

With item **Audio/Radio** you find music files from your local server(s) and USB storage media and you access DVB and Internet radio. The individual subitems are described in detail in the following.

### Calling Audio selection

HOME

**HOME:** Call **Home** view.



▼ ▲ Mark **Audio/Radio**,  
**OK** call list of audio sources.



▼ ▲ Mark function,  
**OK** call.

**DVB radio** The TV set can receive digital radio stations over DVB. For further information on DVB radio see page 69.

**Internet radio** The TV set can receive digital radio stations over the Internet. For further information on Internet radio see page 70.

**MediaHome** **MediaHome** includes both storage media directly connected to the TV set (e.g., USB sticks) as well as data provided in your home network (e.g., from a media server on a PC or a network hard drive). For further information on MediaHome see column on the right.

**MediaNet** Call **MediaNet** → **Browse** → **Music** (see page 75).

## Audio/Radio – MediaHome

**MediaHome** includes both storage media directly connected to the TV set (e.g., USB sticks) as well as data provided in your home network (e.g., from a media server on a PC or a network hard drive).

### Open MediaHome

HOME

**HOME:** Call **Home** view.



▼ ▲ Mark **Audio/Radio**,  
**OK** Call.

▼ ▲ Mark **MediaHome**,  
▶ go to next column.

▼ ▲ Mark desired media source,  
▶ go to next column.

Open Display content of the media source.

Unmount Unmount USB data storage medium before removing it in order to prevent data loss.

Settings opens the audio settings.  
Further information you find starting from page 85.

### Examples of media sources

**Media Center** A Loewe media centre connected to your home network.

**TwonkyMedia WMP11** Examples with media servers in your home network. The exact designation depends on the media server used.

**USB** USB storage media on the USB connections of your TV set. The exact designation depends on the relevant storage medium.

**i** Please also observe the notes on page 143 regarding USB sticks!

**i** The media sources shown here depend on the devices available/used.

### Selecting music titles



▼ ▲ Mark desired directory,  
**OK** open directory.  
Repeat procedure if necessary.



▼ ▲ Mark desired music title,  
▶ open audio function list.

## Audio/Radio function list

The audio/radio function list contains the individual functions for your music titles.



- ▶ Open function list for marked music title.



**Listen** Start or continue playback of the selected music title. See page 66 for further information.

**Sorting** Sort music titles in alphabetical (ascending A-Z or descending Z-A) order, title number, file size or date (newest entries first).

**Favourite** Add music title to the **Home** favourites. See page 33 for further information.

**Rotate TV** Rotating the TV set. See page 42 for further information.

**Settings** opens the audio settings. Further information you find starting from page 85.



- ▼ ▲ Mark desired function,
- OK** Confirm selection.



## Audio playback

### Description of the symbols in the status display for audio playback

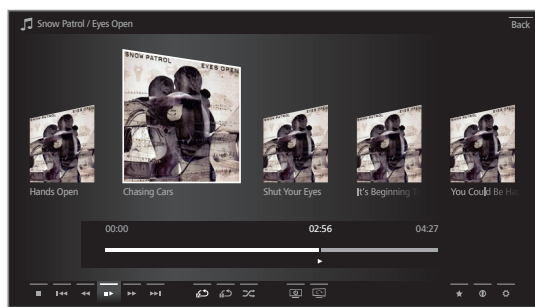

Symbol	Remote control key	Description	Symbol	Remote control key	Description
		End playback and return to music selection.			Switch off the TV screen.
		Stop/continue playback.		-	Rotating the TV set. See page 42 for further information.
	short	Continue halted playback.		-	<b>i</b> Only for playback of music titles from USB storage media or from the home network: Switch repetition (loop playback) of all titles of the current directory ON/OFF.
-	short	<b>i</b> For playback of music titles from USB storage media: Jump to start of the played title / select previous title. <b>i</b> For playback of music titles from the home network: Jump backwards.		-	<b>i</b> Only for playback of music titles from USB storage media or from the home network: Switch ON/OFF repetition (loop playback) of the current title.
-	long	<b>i</b> For playback of music titles from USB storage media: Jump to start of the played title / select previous title.		-	<b>i</b> Only for playback of music titles from USB storage media or from the home network: Switch shuffle playback for the titles of the current directory ON/OFF.
-	short	<b>i</b> For playback of music titles from USB storage media: Winding forwards. Select again for changing the speed. <b>i</b> For playback of music titles from the home network: Jump forwards.			Add the current station / music title to the favourites in <b>Home</b> view.
-	long	<b>i</b> Only for playback of music titles from USB storage media or from the home network: Winding forwards. Select again for changing the speed.			<b>i</b> In case of DVB radio: Show EPG detailed info on the current broadcast. <b>i</b> For playback of music titles from USB storage media or from the home network: Call detailed info on the played music titles.
-		Select next station / title.			Call function list with audio settings.
-		<b>i</b> In case of DVB radio: Select previous station. <b>i</b> Only for playback of music titles from USB storage media or from the home network: Jump to start of the played title / select previous title.			

## Pause playback



**PAUSE key:** Stop current playback.

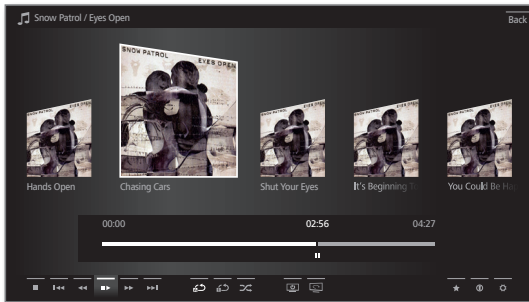

**PLAY key:** Continue playback.

## Wind

You can fast forward music titles at four different speeds. Sound is not audible during winding.



Press **▶▶** longer.

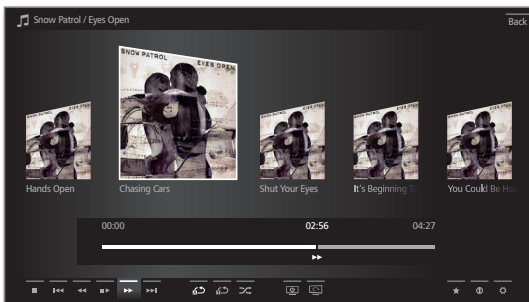

By each pressing of **▶▶** the speed will increase until you switch back to the first speed.  
Available speeds: 2x, 4x, 8x, 16x.

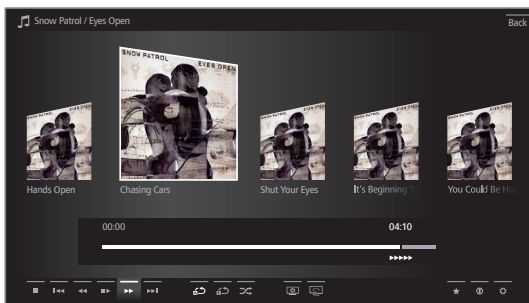

**PLAY key:** Continue playback.

## Select another title / play current title from start



**BACK:** Call music selection.

Select titles as described on page 64.

Or:



Press **P+** :

Play next title of current album / directory.

Press **P-** :

Play current title from start.

Press **P-** again:

Play previous title of the current album / directory.

Or:



**▲ ▼** Go to line with music titles,

**◀ ▶** scroll in music titles.

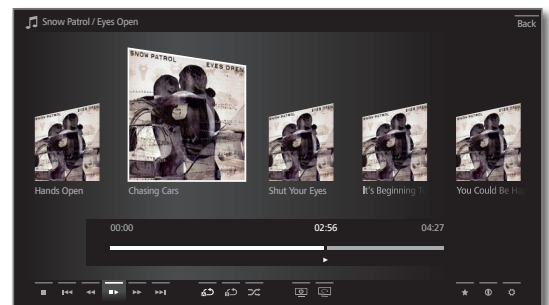

**OK** Start playback of the marked title.

## Jump

**i** Only available for playback of music titles via the home network.

By briefly pressing the **◀◀** or **▶▶** keys you can jump forwards and backwards in the music title. The jump width is adjustable(see page 106).



**▶▶** Jump forwards.



**◀◀** Jump backwards.





## Repeat

Music titles can be repeated, i.e., replayed in an endless loop.



▲ ▼ Show status bar.



▼ ▲ ◀ ▶ Mark **Repeat title** .

**OK** Switch the repetition of the individual music title ON/OFF.

**i** The repeat setting remains until it will be deactivated or another music title is replayed.

Or:



▼ ▲ ◀ ▶ Mark **Repeat all** .

**OK** Switch repetition of all music titles of the current directory ON/OFF.

**i** The repeat setting remains until it will be deactivated or another directory in the overview is selected.

**i** **Repeat title** and **Repeat all** cannot be activated simultaneously. Using one of the two functions deactivates the respective other one.

**i** **Repeat** and **Shuffle** (see below) cannot be activated at the same time. Activating a repeat operation deactivates shuffle.

## Shuffle playback

The music titles of your current medium are replayed in random order.



▲ ▼ Show status bar.



▼ ▲ ◀ ▶ Mark **Shuffle** playback .

**OK** Switch shuffle playback of the titles in current album / directory ON/OFF.

**i** **Repeat** and **Shuffle** (see above) cannot be activated at the same time. Activating the shuffle playback deactivates repeat.

## Switching the screen ON/OFF

    **Green key:** Switch screen OFF.

Or:

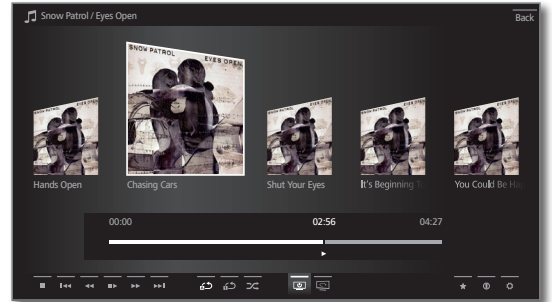

▼ ▲ ◀ ▶ Mark **Screen off** .

**OK** Switch screen off.

**i** Switching off the screen reduces the power consumption of the TV set.

Switch on the screen with the remote control:

    Press **green key**.

Switch on the screen on the TV set:

**RADIO** Press **RADIO** on the local control of the TV set.

## Ending playback



**STOP key:** End playback and return to music selection.

## Radio mode (DVB radio)

The TV set can receive digital radio stations via DVB. In addition you can play the sound from an external device by the TV set via the **audio/AV inputs** of the TV set (see page 132).

**i** The **AUDIO key** has been preset for radio operation in the factory. To change the configuration see page 133.

### Radio mode on

**AUDIO** **AUDIO key** on the remote control  
 Or

**RADIO** Press **RADIO** on the local control of the TV set.

Or:

**HOME** **HOME:** Call **Home** view.

**OK** **OK** call.  
 ▼ ▲ Select **Audio/Radio**,  
**OK** call.  
 ▼ ▲ Select **DVB radio**,  
**OK** call.

You see the radio station list.

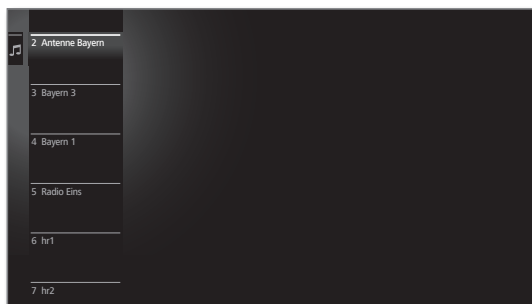

**OK** ▼ ▲ Select station,  
**OK** call.

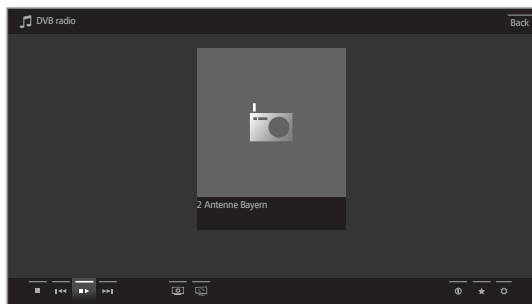

### Setting the volume



**V+ / V-** Volume up/down.

Other sound settings are the same as for the volume setting in TV mode (see page 34).

### Switching the screen on/off

**Green key:** Switch screen OFF.

Or:

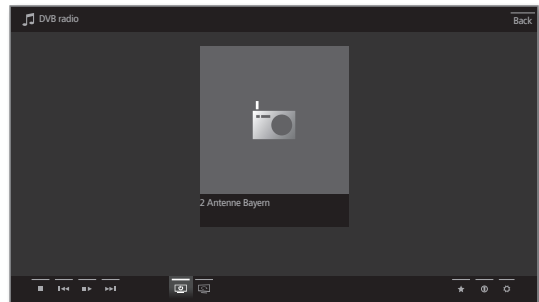

▼ ▲ ◀ ▶ Mark **Screen off**   
**OK** Switch screen off.

**i** Switching off the screen reduces the power consumption of the TV set.

Switch on the screen with the remote control:

**Green key:** Press **green key**.

Switch on the screen on the TV set:

**RADIO** Press **RADIO** on the local control of the TV set.

### Exit radio mode

**AUDIO** **AUDIO key** or

**TV** press **TV key** on the remote control (TV mode is called).

Or:

**HOME** **HOME:** Call **Home** view.

**OK** ▼ ▲ Select another operating mode,  
**OK** call.

### Station switching

**i** The radio mode is switched on and a radio station has been selected (see above).



**P+ / P-** or press the **numerical keys** on the remote control.

Or:

**BACK** **BACK:** call station list.

**OK** ▼ ▲ Select station,  
**OK** call.

## Radio mode (Internet radio)

The TV set can receive digital radio stations via the Internet. In addition you can play the sound from an external device by the TV set via the **audio/AV inputs** of the TV set (see page 132).

**i** The names of the directories and stations in the Internet radio mode are given by the provider vTuner. Changing the arrangement of stations or renaming them is not possible here.

**i** Internet radio is only accessible if a connection to the Internet has been established.

### Radio mode on



**HOME:** Call **Home** view.



◀ ▶ ◂ ▸ Select **Audio/Radio**,  
**OK** call.

▼ ▲ Select **Internet radio**,  
**OK** call.

You see the radio station list.

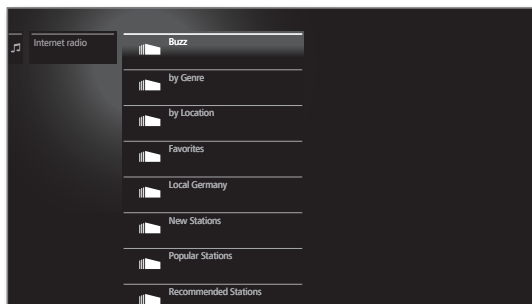

▼ ▲ Mark desired directory,  
**OK** open directory.  
 Repeat procedure if necessary.

▼ ▲ Select station,  
**OK** call.

**i** For further information on the control of the Internet radio see page 66.

### Station switching



**BACK:** call station list.

Select stations as described in the left column.

Or:



**P+ / P-** Scroll through the current Internet radio directory to look for stations.

### Setting the volume



**V+ / V-** Volume up/down.

Other sound settings are the same as for the volume setting in TV mode (see page 34).

### Switching the screen on/off



**Green key:** Switch screen OFF.

Or:

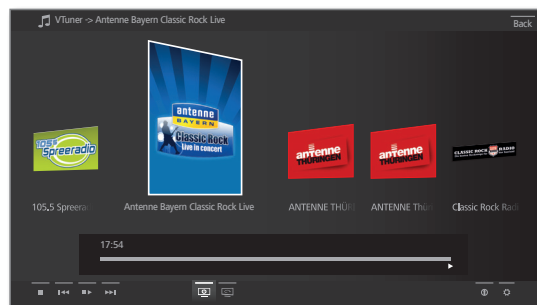

▼ ▲ ◂ ▸ Mark **Screen off**   
**OK** Switch screen off.

**i** Switching off the screen reduces the power consumption of the TV set.

Switch on the screen with the remote control:



Press **green key**.

Switch the screen on with the remote control:

**RADIO**

Press **RADIO** on the local control of the TV set.

## Photo

Via menu item **Photo** you can view photos from your local media and from online sources on your TV screen. The individual subitems are described in detail in the following.

### Calling Photo selection

HOME

**HOME:** Call **Home** view.



▼ ▲ Mark **Photo**,

**OK** call list of photo sources.



▼ ▲ Mark function,

**OK** call.

**MediaHome** **MediaHome** includes both storage media directly connected to the TV set (e.g., USB sticks) as well as data provided in your home network (e.g., from a media server on a PC or a network hard drive).

For further information on MediaHome see column on the right.

**MediaNet** Call **MediaNet** → **Browse** → **Photo** (see page 75).

## Photo – MediaHome

**MediaHome** includes both storage media directly connected to the TV set (e.g., USB sticks) as well as data provided in your home network (e.g., from a media server on a PC or a network hard drive).

### Open MediaHome

HOME

**HOME:** Call **Home** view.



▼ ▲ mark **Photo**,

**OK** call.

▼ ▲ mark **MediaHome**,

**OK** go to next column.

▼ ▲ Mark desired media source.

**OK** go to next column.

Open Display content of the media source.

Unmount Unmount USB data storage medium before removing it in order to prevent data loss.

Settings opens the audio settings.  
Further information you find starting from page 85.

### Examples of media sources

**TwonkyMedia WMP11** Examples with media servers in your home network. The exact designation depends on the media server used.

**USB** USB storage media on the USB connections of your TV set. The exact designation depends on the relevant storage medium.

**i** Please also observe the notes on page 143 regarding USB sticks!

**i** The media sources shown here depend on the devices available/used.

### Selecting a photo



▼ ▲ Mark desired directory,

**OK** open directory.

Repeat procedure if necessary.

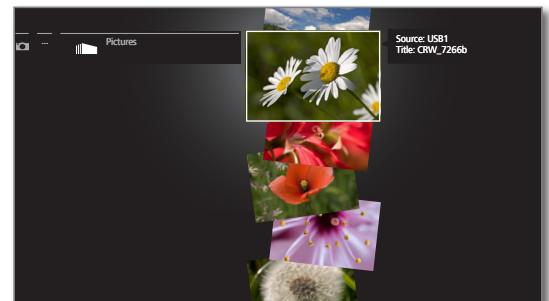

▼ ▲ Mark desired photo,

▶ open photo function list.

## Photo function list

The photo function list contains the individual functions for your photos.



- ▶ Open function list for the marked photo.



Example view: Photos on a USB storage medium

Full screen	View photo zoomed to full screen. For further information see column on the right.
Slide show	Start slide show of the photos in the currently selected directory. See page 73 for further information.
Sorting	Sort photos in alphabetical (ascending A-Z or descending Z-A) order, file size or date (newest entries first).
Favourite	Add photo to the <b>Home</b> favourites. See page 33 for further information.
Rotate TV	Rotating the TV set. See page 42 for further information.
Settings	opens the audio settings. Further information you find starting from page 85.



- ▼ ▲ Mark desired function,
- OK** Confirm selection.

## Photo display

### Description of the symbols in the status display for photos



Symbol	Remote control key	Description
■	■	Photos in full screen view / end slide show and return to photo selection.
<	◀◀ short	Show previous photo.
>	▶▶ short	Show next photo.
↶	-	Rotate photo by 90 degrees to the left.
↷	-	Rotate photo by 90 degrees to the right.
▶	▶ (green)	Start slide show.
⏸	⏸ (red)	Pause current slide show.
📺	-	Rotating the TV set. See page 42 for further information.
ℹ	INFO	Call detailed info on the displayed photo.
★	★	Add currently displayed photo to the favourites in <b>Home</b> view.
⚙	MENU	Call function list with photo settings.

## Full-screen mode

**i** A photo is marked.



**OK** View photo in full-screen mode.



Show previous / next picture.

## Rotating the photo



▲ ▼ On-screen display of status bar.

◀ ▶ Mark or .

**OK** rotate photo by 90 degrees to the left/right.

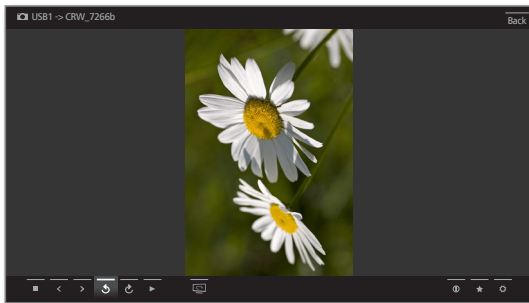

## Slide show



**PLAY key:** Start slide show.

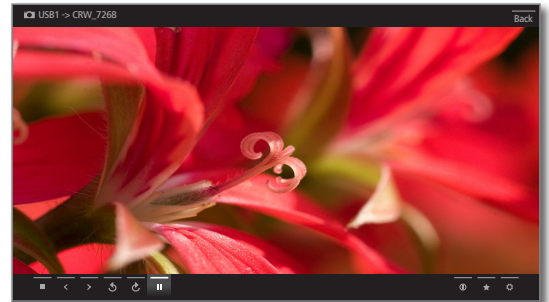

**PAUSE key:** Pause slide show.



**PLAY key:** Continue paused slide show.

## Photo in full-screen mode / exit slide show



**STOP key:** Full-screen mode / end slide show and return to photo selection.



## Web

Here you have access to multimedia content in the Internet (MediaNet) as well as a high-quality web browser.

### Calling the Web selection

HOME

**HOME:** Call **Home** view.



▼ ▲ Mark **Web**,  
**OK** call Web.

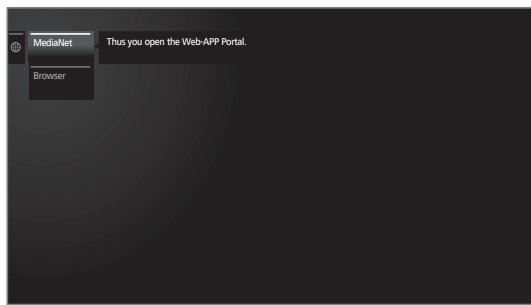

▼ ▲ mark function,  
**OK** call.

**MediaNet** Under the menu item **MediaNet** you will find a continually expanding platform for interactive TV applications from the Internet.

All applications are optimised for use on the TV.

**Browser** Call Web browser of the TV set.

For further information on the Web browser see page 76.

## MediaNet

### Call MediaNet

WEB

**WEB:** Call **MediaNet**.

or

HOME

**HOME:** Call **Home** view.



◀ ▶ ▼ ▲ Select **Web**,  
**OK** call.

▼ ▲ Mark **MediaNet**,  
▶ call.

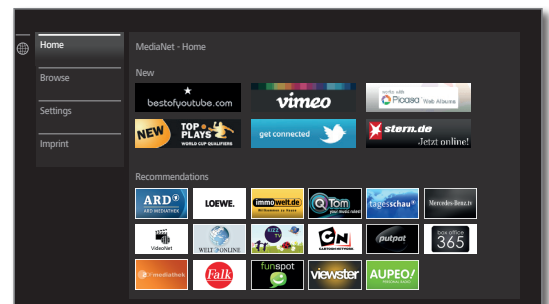

The upper portion of the MediaNet home screen contains new online content.

The lower portion of the MediaNet home screen contains **Recommendations** given by Loewe.

**i** The given content may change from time to time without prior notice.



▲ ▼ Select **Home**,  
**OK** go to the right to choose the online content.

◀ ▶ ▲ ▼ Mark the desired online content,  
**OK** Display/play content.

**i** The navigation within the various applications depends on the provider.

### Functions in the MediaNet home screen

- Home** Moves to the right to choose the online content.
- Browse** Under **Browse** you can list and call the online content by subjects.  
See page 75 for further information.
- Settings** In the **Settings** for MediaNet you can select countries, for example, to take advantage of various services.  
See page 75 for further information.
- Imprint** Providing the legally required information on the parties responsible for the content.

### Exit MediaNet

HOME

**HOME:** Call **Home** view and select another function.



## MediaNet – Browse

**i** MediaNet-Browse is called (see page 74).

Under the item Browse, you browse the full range of applications by topic.

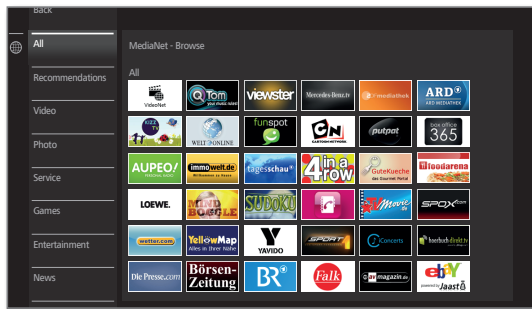

## Filtering applications



▼ ▲ Select the genre / topic,  
**OK** call applications of the genre.

◀ ▶ ▼ ▲ Select desired application,  
**OK** open application.

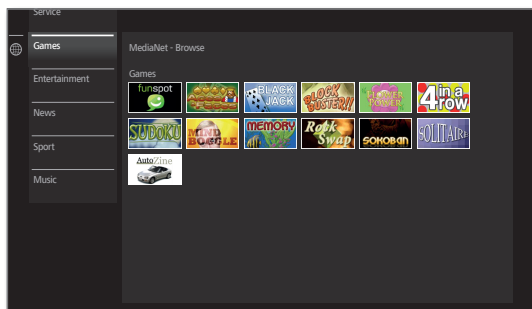

## Change filter



◀ Go to column with genres / topics.

▼ ▲ Select another genre / topic,  
**OK** call applications of the selected genre.

## Exit Browse



**BACK:** Return to the MediaNet home screen.

Or:



◀ Go to column with genres / topics.

▲ ▼ Select **Back**,  
**OK** return to the MediaNet home screen.

## Define application as favourite



◀ ▶ ▼ ▲ Mark the desired application.



Add the marked application to the **Home** favourites.

The favourite will be added to **Home** view and placed at the end.

## MediaNet – Settings

**i** MediaNet settings are called (see page 74).

Here, you can find setting options for MediaNet.

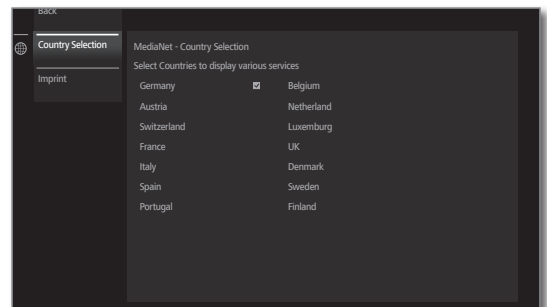

▼ ▲ Select the desired setting,  
**OK** call.

Country Selection Select countries from which you want to get information on services (see below).

Imprint Providing the legally required information on the parties responsible for the content.

## Country Selection



◀ ▶ ▼ ▲ Mark country,  
**OK** select / deselect country.

Applications from countries that are marked with a tick  here, are offered in **MediaNet**.

## Exit Settings



**BACK:** Return to the MediaNet home screen.

Or:



◀ Go to column with settings.

▼ ▲ Select **Back**,  
**OK** return to the MediaNet home screen.

## Browser

You can access Internet sites directly using the integrated Opera browser. The web browser can also be used without an Internet connection. Thus you can access local devices which provide a web interface (e.g. router, home control, home network server).

### Calling the Web browser

HOME

**HOME:** Call **Home** view.



▼ ▲ Select **Web**,  
**OK** call.

▼ ▲ Select **Browser**,  
**OK** call.

Start page will be opened.



INFO

**INFO:** display browser status.

### Explanation of the symbols in the browser status



Define current site as **homepage**.



**Update** the displayed Internet **site**.

100% Change **zoom** factor of the displayed site / browser.



**Add** displayed Web site **to Home view** (in the **Favourites** area).

### Navigating on Web sites



**P+ / P-** Scroll page vertically.



◀ / ▶ Scroll page horizontally.



◀ ▶ ▲ ▼ Select link or text input field,  
**OK** open link or confirm text input.



For the entry of text, press the numerical key (0-9) repeatedly as with a mobile phone until the desired character appears. The available letters are printed on the individual numeric buttons.

BACK

**BACK:** Stop text entry and exit entry box.

### Entering a URL (Internet address)

**i** Browser status is displayed.



◀ ▶ ▲ ▼ Mark the URL (Internet address) of the indicated Internet site,

**OK** Open address entry box.

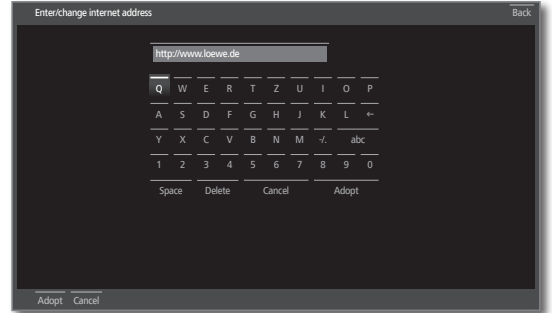

◀ ▶ ▲ ▼ Select required character,  
**OK** Adopt character.

← Delete character to the left of the cursor.

-./ Enter special character (select repeatedly for more characters).

abc Switch between upper/lower case.

Space Enter blank space.

Delete Delete all characters.

Cancel Cancel input. The entry box will be closed and the previous Internet site will be displayed again.

Adopt Adopt address and open new Internet site.



**i** The characters may also be entered by the USB keyboard or the numerical keys of the remote control (see left column).

### Exit Browser

HOME

**HOME:** Call **Home** view and select another function.

## Extras

**Extras** contains additional functions and settings (e.g., Timer list, AV selection, CA module settings).

### Call Extras

HOME

**HOME:** Call **Home** view.



◀ ▶ ▲ ▼ Mark **Extras**.  
**OK** call Extras.



### Explanation of the subitems of Extras

Timer	Under menu item Timer you find your saved Timer Instructions (see right-hand column).
Software	Carry out software update (see page 101).
DR+ Streaming	Switch off the TV set to be in an advanced standby mode (server function). The access to your TV entries remains activated for a preset time. See page 84 for further information.
Energy efficiency	Here you can determine how energy efficient your TV set shall be (see page 101).
CA module 1 CA module 2	Make settings for your CA modules (see page 81). <b>i</b> This menu item appears only if at least one CA module is plugged in. <b>i</b> The exact designation of the menu item and available subitems depends on your CA module(s).
Special functions	Here, you find the equipment overview of your TV set and repeat the initial installation (see page 83). Moreover, you reset the various settings to the factory settings here.
AV selection	opens AV selection (see page 83).

## Timer

### Timer Instructions

All programmed recordings, marked programmes and copy jobs are listed in the Timer Instructions overview.

You can also programme new recordings, mark other programmes and copy pre-recorded programmes from the DR+ archive to an external USB hard disc by means of the Timer Instructions.

**i** When you have programmed timer recordings, the TV set can only be switched off to the standby mode. **Never** switch the TV set off at the mains and do **not** pull out the plug of the TV set out of the socket. Otherwise no timer recordings can be made.

### Call Timer instructions

HOME

**HOME:** Call **Home** view.



◀ ▶ ▲ ▼ Mark **Extras**.  
**OK** call Extras.

▼ ▲ Mark **Timer**.

- ▶ The overview of Timer Instructions will be displayed.

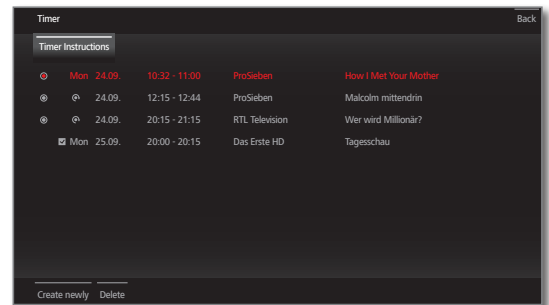

Create newly	Create new timer instruction (recording, copy, memo). Further information you find starting from page 78.
Delete	Delete one or several timer instructions. See page 79 for further information.

### Explanation of the symbols in the overview of timer instructions:

- Record
- Recording in progress
- Marked programme (see pages 39 and 79)
- Repeated recording (daily, weekly or Mon-Fri)

### New instruction: New recording

**i** In overview of Timer Instructions:



◀ ▶ ▾ ▶ Mark **Create newly**,  
**OK** call.

◀ ▶ ▾ ▶ Mark **New recording**,  
**OK** call. The function list for recording will be opened.

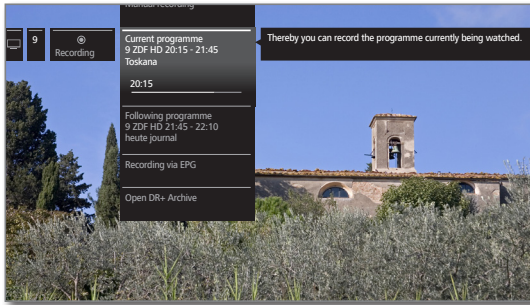

▼ ▲ Mark the desired option,  
 ▶ proceed.

### New recording – Manual recording (current station)

**i** In the overview of the Timer Instructions, **New recording** is selected.



▼ ▲ Mark recording duration.

**i** The selection of a recording duration programmes always a recording of the currently viewed station. For **Any station and time** see below.



**OK** Call **Timer data** dialogue.

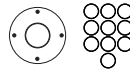

**i** The selected recording duration is preset in the timer data. Check timer data and correct them, if required. In case of a previous selection of **??? Min**, enter definitely the recording duration.

**i** For the explanation of the menu items in the timer data see page 80.



▼ ▲ Mark **Adopt to Timer**.

**OK** Confirm timer data and adopt timer instruction. Recording has been started.

### New recording – Manual recording (other station)

**i** **Manual recording** has been selected (see above).



▼ ▲ Mark **Any station and time**.

**OK** Call **Station selection**.

◀ ▶ ▾ ▶ Mark desired station,

**OK** Adopt station in timer data.

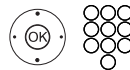

Check timer data and correct them, if required.

**i** For the explanation of the menu items in the timer data see page 80.



▼ ▲ Mark **Adopt to Timer**.

**OK** Confirm timer data and adopt timer instruction.

Manual recording Programme the recording manually. For further information see column on the right.

Current programme Record currently watched TV programme.  
**i** Menu item will only be indicated when EPG data are available for the current station. See page 79 for further information.

Following programme Record following programme.  
**i** Menu item will only be indicated when EPG data are available for the current station. See page 79 for further information.

Recording via EPG Programme recording of a programme via the electronic programme guide (EPG). See page 39 for further information.

Open DR+ archive opens the DR+ archive (see page 49).

## New recording – Current programme

After calling the **Current programme** (see page 78) the timer data dialogue will be displayed. The current programme is preset in the timer data.

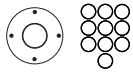

Check timer data and correct them, if required.

For the explanation of the menu items in the timer data see page 80.



▼ ▲ Mark **Adopt to Timer**.

**OK** Confirm timer data and adopt timer instruction. Recording has been started.

## New recording – Following programme

After calling the **Following programme** (see page 78) the timer data dialogue will be displayed. The following programme of the current station is preset in the timer data.

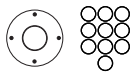

Check timer data and correct them, if required.

For the explanation of the menu items in the timer data see page 80.



▼ ▲ Mark **Adopt to Timer**.

**OK** Confirm timer data and adopt timer instruction.

## New copy job

You should copy recordings that you want to save permanently on an external USB hard disk.

**i** Copying recordings, which originate from a CI Plus encrypted station, is perhaps not possible or only to a limited extent (see page 82).

**i** In overview of Timer Instructions:



◀ ▶ ▲ ▼ Mark **Create newly**.

**OK** call.

◀ ▶ ▲ ▼ Mark **New copy**.

**OK** call.

The DR+ archive will be called. For further information on copying refer to chapter **Digital-Recorder – Overview of functions** starting from page 45.

## New memo

You memorise interesting programmes, which have not started yet, using the electronic programme guide (EPG).

**i** In overview of Timer Instructions:



◀ ▶ ▲ ▼ Mark **Create newly**.

**OK** call.

◀ ▶ ▲ ▼ Mark **New memo**.

**OK** call.

EPG will be called. For further information on Memorise refer to chapter **Electronic Programme Guide** starting from page 38.

## Record conflict

If you wish to programme a new recording which overlaps a timer recording already saved, the **Recording conflict** dialogue will open. Determine whether one or both recordings are to be made here.

If you decide for both, you have to state which of the two programmes is to be recorded fully.



**BACK:** Interrupt programming of the new recording. Update timer data of the newly programmed recording.

## Delete programmed timer instruction

Use this function in the overview of timer Instructions if you want to delete recordings already programmed or end a running timer recording.

**i** The Timer Instructions are displayed.



◀ ▶ ▲ ▼ Mark **Delete**.

**OK** call.

▼ ▲ Mark the timer instruction to be deleted.

**OK** Memorise timer instruction for delete.

The text of a timer instruction to be deleted is white.

Ahead of the entry appears a delete icon

If required, memorise further entries.

**i** The text of a currently active timer instruction is red. If you delete this timer, the recording is stopped.

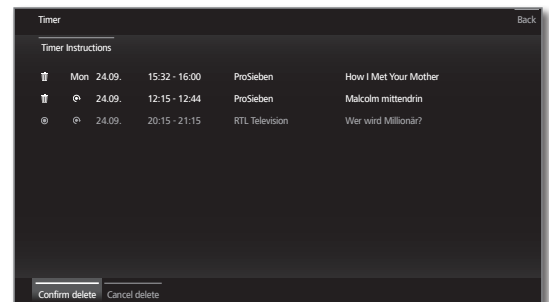

◀ ▶ ▲ ▼ Mark **Confirm delete**.

**OK** Delete timer instructions.

## Entering the Timer data

After selecting the station you wish to record, timer data will be displayed.

The setting options for the timer data differ depending on the recorder selection, whether an analogue or DVB station is to be recorded or via which route (EPG, manually) the recording has been programmed.

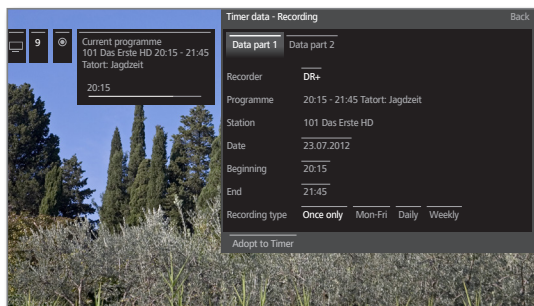

▲ ▼ ◀ ▶ Update **timer data**, if required, or press **OK** for confirmation.

**i** If an external DVD recorder was selected as recording source, start replay at the connected device manually from the beginning of the entered recording time.

**i** For recording encrypted broadcasts, please also refer to the information on page 82.

## Explanations of the setting options in the menu Timer data- part 1

Station	(only available when the selected station can be received via different signal sources, e.g. DVB-T and DVB-S) Select the signal source for the recording.
Date	Day of recording.
Beginning	Starting time of the recording.
End	End time of the recording.
Recording type	Programmes can be recorded in different ways: <b>Once only</b> : The programme will be recorded at the specified time. <b>Mon-Fri</b> : The programme will always be recorded from Monday to Friday at the specified time. <b>Daily</b> : The programme will be recorded every day at the specified time. <b>Weekly</b> : The programme will be recorded every week at the specified time.

## Explanations of the setting options in the menu Timer data- part 2

Lock recording Only allow later playback of this recording after entering the PIN number (Parental lock).

**i** If a PIN still has not been entered under **System settings → Control → Parental lock**, the **Parental lock** will at first be activated.

Delete protection Safeguard the recording from being deleted automatically by using the delete manager. (see page 51).

Auto time control <sup>1</sup> Your TV set can use the automatic time control (Accurate Recording) for recording a programme. The **automatic time control** takes control of the corresponding monitoring of the start and end time for DVB stations. The recording is started at the beginning of the broadcast and switched off at the end, even if the start and/or end time have been changed by the programme provider.

**i** The automatic time control is not supported by all stations.

**i** If **yes** is selected and automatic time control is **not** supported by the recorded channel then **no** recording is made.

**i** If the programme information (Event-ID) should not be available any more for the recording of a programmed broadcast, e.g., due to a programme change or because the Event-ID has been changed by the station, the programme **cannot** be recorded. The broadcasters alone are responsible for the transfer of this data for using **automatic time control**. The availability of the appropriate data cannot be guaranteed by Loewe.

Recording subtitles Select whether broadcast subtitles are to be recorded too.

**i** In case of a **direct recording** (page 47) the presetting is taken from **System settings → Control → more ... → DR+ → Recording subtitles** (page 106).

Favourite When selecting **yes** the recording will be added to the **Home** favourites.

<sup>1</sup> only available for programming of the recording via EPG.

## Conditional Access module (CA module)

In order to receive coded digital stations, a Conditional Access module (CA module) and a Smart Card must be inserted in the CI slot of your TV set (see page 11).

The CA module and the Smart Card are not part of the set of equipment supplied with the TV set. They are usually available from your dealer. Loewe does not provide any guarantee for the functioning of the CA module.

The TV set must first recognise and set up the CA module during initial operation. Therefore, it can take up to a minute until decoding starts during initial operation.

### Inserting the Smart Card into the CA module

Push the side of the card with the gold chip on it should be pointing towards the thicker side of the insertion slot (see illustration). Note the direction of the arrow printed on the Smart Card.

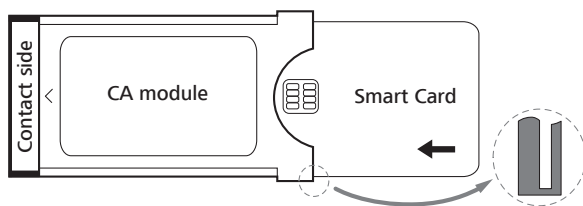

### Inserting the CA module into the TV set's CI slot

**i** Switch off TV set using the mains switch.

Remove the cover from the rear of the set.

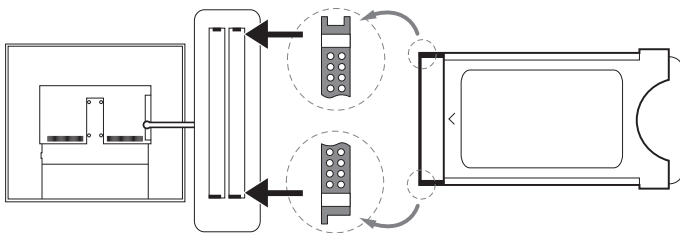

Insert the CA module carefully into one of the two CI slots, ensuring that the contact side goes in first. Do not use force. Make sure the module is not twisted in the process. Push the CA module in as far as it will go.

Finally, close the side cover.

### Searching for scrambled stations

HOME

**HOME:** Call Home view.



◀ ▶ ▾ ▹ Select **System settings**.

**OK** call System settings.

▼ ▲ Mark **Stations**.

▶ go to next column.

▼ ▲ **Automatic scan TV+Radio**.

▶ go to next column.

◀ ▶ Select **Change search settings**.

**OK** wizard guides you through the search settings.

**i** For a description of the search settings see starting from page 93.

**i** Under **scrambled stations** you have to select **yes**.

◀ ▶ Next select **Start search/update**.

**OK** start updating the station list.

### Calling CA module information

**i** This menu is only available when a CA module is plugged in.

HOME

**HOME:** Call Home view.



▼ ▲ Mark **Extras**.

**OK** call Extras.

▼ ▲ Select desired CA module.

**i** The indicated name depends on the inserted CA module.

▶ go to next column.

▼ ▲ Select **CA module**.

**OK** call information.

The content of this menu depends on the provider of the CA module.

### Removing the CA module

**i** Switch off TV set using the mains switch.

Remove the cover from the rear of the set.

Pull the CA module out of the CI slot.

Replace the cover.



## DVB Common Interface Standard (CI)

Selection possibilities in the CA module menu and performance capability of your CA module depend on the type of module used and the software installed on it. Consult the manufacturer of the module if you have any questions.

## Troubleshooting (CA module)

The following information can help, if problems should occur when running a CA module:

Switch the TV set off to the standby mode. Remove the CA-module from the TV set. Switch the TV set off completely. Wait a few seconds. Reinsert the CA module. Switch the TV set on again.

If errors continue to occur, make a note of the displayed two-digit error code (only possible for CI Plus capable CA modules) and contact your dealer.

## DVB Common Interface Plus Standard (CI Plus)

CI Plus is an advanced development of the DVB Common Interface Standard. CI Plus slots are in principle downward compatible to the previous CI standard, i.e. CA modules and Smart Cards according to the past CI standard can continue to be used in CI Plus slots, as far as the programme provider permits this.

Programme providers, who use the CI Plus standard, can assign different rights for their broadcast programmes. For instance, the programme provider can restrict or completely prevent recording or later watching of an encoded programme. If there are such regulations, these also apply to time-shifted watching of television programmes. A screen message informs you of this fact, if you would like to record such a programme. Recording is carried out in such a case (an appropriate entry is displayed in the DR+ archive), later watching of the programme is however not possible at all or only for a limited period (e.g., 10 days). A possible time limitation of the playback will also appear in the corresponding entry in the DR+ archive.

**i** All restrictions mentioned here are the responsibilities of the broadcaster. The TV set simply values the broadcaster set signalling as neutral.

Furthermore, the programme provider can prevent external copying of protected programmes.

It could be necessary to enter the parental protection PIN of the CA module when programming the data, if you want to record a CI Plus protected programme, which has been protected against viewing by minors. The Parental lock PIN can also be store in the TV set (see page 109). The secret number of the TV set is required for watching the programme later.

The appearance of the CA module menu depends on the manufacturer of the module.

### Software update for CI Plus capable CA modules

Every now and then, there will be new system software for your CA module software. There are two software update types.

Recommended update:

Information on an available update is displayed. You can either run this or cancel the procedure. If you do not install the update, the information will reappear in regular intervals until the update has been installed.

Forced update:

Information on an available update is displayed. The module does not decode any more until the update has been successfully implemented.

## Special functions

### Calling special functions

HOME

**HOME:** Call **Home** view.



◀ ▶ ▲ ▼ Mark **Extras**,  
**OK** call Extras.

▼ ▲ Mark **Special functions**,  
 ▶ go to next column.



▲ ▼ Select desired function,  
 ▶ proceed to next column.

### Explanations of the setting options in the Special functions menu:

Integrated features Here you can obtain information on the integrated features of your TV set.

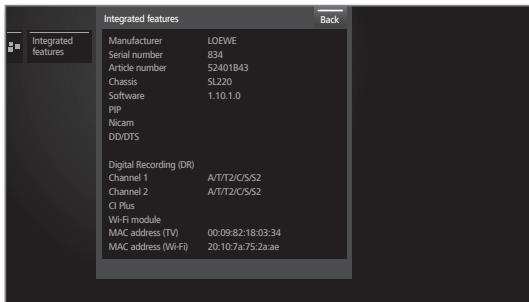

Repeat initial installation You can repeat the Initial installation again at any time. You are guided through the various menus where i.a. an automatic TV/radio station search is automatically carried.

**Caution:** All stored stations and all created personal lists will be deleted by this!

For the procedure of the initial installation see starting from page 20.

**i** If a parental lock is activated, the access code must be entered before repeating initial installation (see **Parental lock** on page 100).

Reset to factory settings Reset the settings of Picture/Sound, Speaker system or Network to factory settings.

## AV selection

### Selecting the AV source via the AV selection

**i** In normal TV mode, without other displays:



Call **AV selection**.

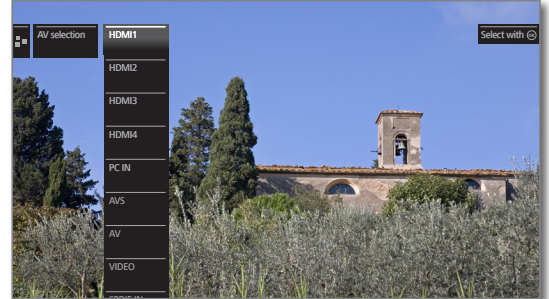

▼ ▲ Select desired connection,  
**OK** switch over.

If the selected AV source provides a signal (picture), it should be visible now.

For the **VIDEO** selection the set switches to **cable analog**, channel **E36**. The TV set shows the signal of a signal source device via antenna.

### Selecting the AV source via the station list

**i** In normal TV mode, without other displays:



**OK** call station list.  
 ◀ Call overview of station lists.

▼ ▲ Mark list **AV**.  
 The AV list will be displayed.

▶ Move to the AV list.



▼ ▲ Mark desired AV source,  
**OK** switch to AV source.

## DR+ Streaming

Here, you can switch off the TV set to the advanced standby mode for DR+ Streaming.

### Advanced standby mode with DR+ Streaming access

Switching off the accessible TV set ends access to the DR+ archive. You can, however, switch your TV set to an advanced standby mode to enable access to the DR+ archive even when the TV set is switched off (server function).

HOME

**HOME:** Call **Home** view.



◀ ▶ ▲ ▼ Mark **Extras**,

**OK** call Extras.

◀ ▶ ▲ ▼ Mark **DR+ Streaming**.

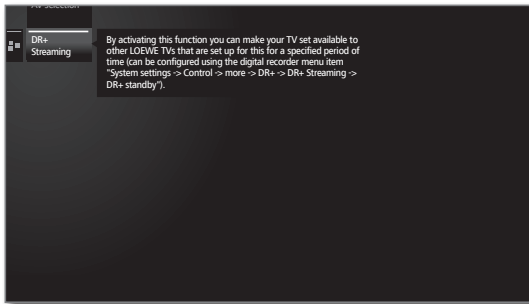

**OK** Confirm.

The TV set will switch to the advanced standby mode. The DR+ archive will then be accessible within the network for the period of time set in the **DR+ Streaming - Settings** (see page 106).

## System settings

Under the menu item **System settings** in the **Home** menu you find all settings and adaptabilities of your TV set. These are explained to you more in detail as follows.

### Calling System settings

HOME

**HOME:** Call **Home** view.



◀ ▶ ▲ ▼ Mark **System settings**.  
OK call.

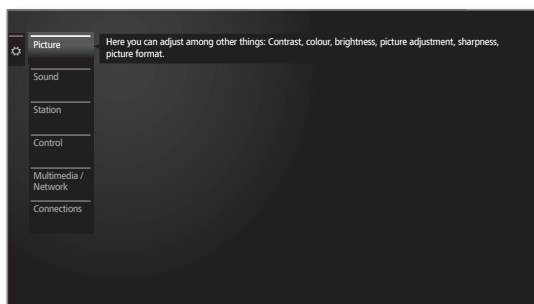

### Explanations of the setting options:

- Picture Here you do the settings referring to the representation of the picture signal on your TV set.  
For explanations of setting possibilities in the **Picture** menu see page 86.
- Sound Under this menu item you find the settings for sound playback.  
The subitems of the menu depend on the currently selected sound component.  
For explanations of setting possibilities in the **Sound** menu see page 90.
- Stations Move and delete TV and radio stations. In addition to that you can automatically and manually update the complete station list. Your stations can also be arranged and optionally sorted in personal lists.  
For explanations of setting possibilities in the **Stations** menu see page 91.
- Control In this menu you find settings for additional functions of your TV set like picture in picture (PIP) and digital recorder (DR+) as well as interfunctional settings like time and date, parental lock or software update.  
For explanations of setting possibilities in the **Control** menu see page 98.
- Multimedia / Network By means of the Multimedia / Network menu you configure your network adaptor and network access. Moreover, you can make settings for video and music playback here.  
For explanations on the network settings see page 114. For explanations on the Multimedia settings see page 117.
- Connections Using this menu you configure external devices that are connected to one of the numerous connections of the TV set.  
Explanations of setting possibilities in the **Connections** menu see page 118.



## Picture

Here you do the settings referring to the representation of the picture signal on your TV set.

### Calling picture settings

HOME

**HOME:** Call **Home** view.



◀ ▶ ▲ ▼ Mark **System settings**,  
**OK** call System settings.

▼ ▲ Mark **Picture**,  
▶ go to next column.

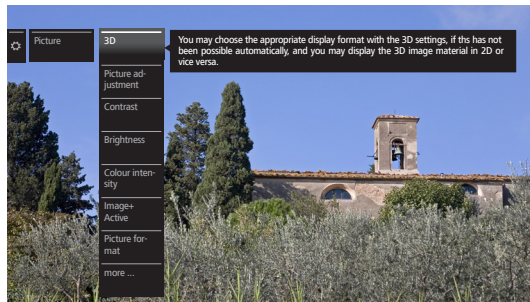

▲ ▼ Select desired picture function,  
▶ proceed to next column.

### Explanations of the picture settings:

3D	Do the settings for your TV set's 3D display (see page 88).
Picture adjustment	You can switch between three preset picture settings and the three personal picture values that you have adjusted (see page 87).
Contrast	The contrast setting depends on the brightness of the room. The brighter the surroundings the higher the contrast should be set. The power consumption of the TV set depends directly on the value set here (see also page 20).
Brightness	Set the brightness so that the black areas of the picture only just appear black.
Colour intensity	Set the colour intensity to suit your personal taste.
Image+ Active	Picture enhancement on/off.
Picture format	Set picture format (see page 87).
<b>more ...</b>	call with <b>OK</b> (see right-hand column).

### Explanations of the picture settings (continuation):

Colour temperature	Here, you can give the TV picture a warmer or colder hue according to your personal taste.
Sharpness	Here you can adjust picture sharpness to obtain the best definition.
Move picture up/down	When using the TV aspect ratios Panorama or Zoom, the text or graphic displays at the top and bottom are not or only partially visible. You can move the picture up or down with the up/down menu control keys to make the displays visible.
Auto dimming	depending on video (VBD+): The background lighting is reduced depending on the current video content and the video signal is simultaneously amplified in order to get an improved contrast of your TV picture. depending on the environment (OPC): The contrast of your TV picture is automatically reduced vs. decreasing room brightness (Optical Power Control – OPC). <b>i</b> The automatic dimming also results in a lower power consumption of the TV set. <b>i</b> Due to a reduction in the luminance in 3D mode for technical reasons, this function is deactivated when showing 3D content.
Film quality improvement (DMM)	DMM reduces jolt in rapid picture object movements and rolling text displays. This applies especially for movies.
Digital Noise Control (DNC)	With active DNC (Digital Noise Control) you can eliminate or reduce picture noise.
Skin tone	Adjust the skin tone so that the most natural facial skin colour is achieved.
Deblocking filter	To minimise the visible interference to the picture caused by modern compression methods for images and image sequences (formation of small blocks), a so-called deblocking filter can be activated which counteracts this interference.
PC IN display	For some PC image formats, horizontal as well as vertical position and the phase position of the image can be corrected.

## Picture adjustment

By selecting one of the three presets (**Home Mode**, **Premium Mode** or **Shop Mode**), the picture settings for whichever signal input group that is currently active will be set to predefined settings. For the explanations of the **signal input groups** see page 144.

You can use **Personal Mode** to specify individual settings for contrast, colour intensity, colour temperature, sharpness and digital noise suppression. Here you can enter your own specifications for each signal input group.

### Calling picture adjustment

HOME

**HOME:** Call **Home** view.



◀ ▶ ▲ ▼ Mark **System settings**.

**OK** call System settings.

▼ ▲ Mark **Picture**.

▶ go to next column.

◀ ▶ Mark **Picture adjustment**.

▶ go to next column.

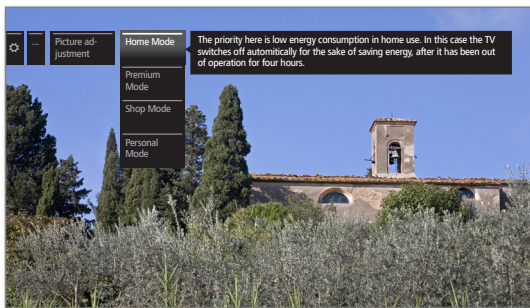

▼ ▲ Select mode.

**OK** adopt selected mode.

**i** When selecting one of the three preset picture adjustment modes you have to specify additionally if the mode shall be set only for the currently selected signal source, e.g., **Only for HD Digital** or **for the entire TV**.

### Explanations of the picture adjustment modes:

Home Mode	The emphasis for the picture settings is here on low energy consumption for home use. In this case, the TV set switches automatically off after 4 hours of unattended time.
Premium Mode	The picture settings in Premium Mode are optimised for a brighter environment at the cost of higher energy consumption.
Shop Mode	The picture settings in Shop Mode are adjusted to operation in the presentation room.
Personal Mode	Here, you can recall your last personal picture settings.

## Selecting the picture format

**i** The setting options depend on the transmitted picture content.

HOME

**HOME:** Call **Home** view.



◀ ▶ ▲ ▼ Mark **System settings**.

**OK** call System settings.

▼ ▲ Mark **Picture**.

▶ go to next column.

◀ ▶ Mark **Picture format**.

▶ go to next column.

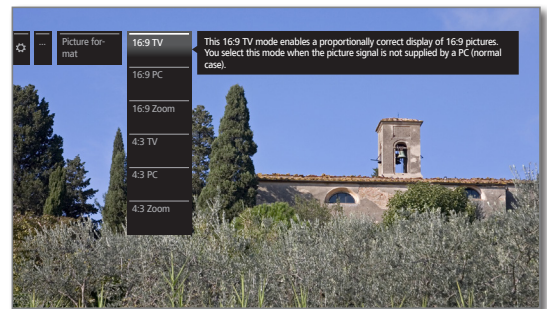

▼ ▲ Select format.

**OK** adopt selected format.

### Explanations of the picture formats for HD signals:

4:3 TV	Proportionally correct display of 4:3 or 16:9 broadcasts. You select this mode when the signal is not supplied by a PC (normal case). A small part of the picture is truncated. This may be necessary to hide possible interference at the edge of the picture, which arises from the signal supplied.
16:9 TV	
16:9 PC	Proportionally correct display of 4:3 or 16:9 broadcasts without loss of information. You select this mode when the signal is supplied by a PC.
16:9 Zoom	
4:3 Zoom	Proportionally correct display. Maximum picture magnification. Displayed text may get lost.
16:9 Zoom	

### Explanations of the picture formats for SD signals:

16:9	Proportionally correct display of 16:9 broadcasts.
4:3	Proportionally correct display of 4:3 broadcasts.
Panorama 1	Proportionally correct display of 4:3 broadcasts on the 16:9 screen. Station logo and subtitles remain visible.
Panorama 2	Format filling display (factory default) of 4:3 broadcasts on the 16:9 screen. Station logo and subtitles remain visible.
Zoom	Proportionally correct display. Maximum picture magnification. Displayed text may get lost.
PALplus	Is a 4:3-compatible 16:9 picture broadcast supplied by the station which is detected automatically.



### 3D function

You can use the 3D functionality of your TV set to display 3D material transmitted by a channel or from an external player that is connected.

You require a pair of **Loewe Active Glasses 3D** to be able to use the 3D functionality in its entirety (see Accessories on page 145). Please read the operating instructions included with the 3D glasses.

### 3D settings

Using the 3D settings you can select the correct display format, should this not have been detected automatically. What's more, you can choose to view 3D material in 2D or "traditional" 2D material in 3D.

For 3D content that is being played back from an external HDMI player, the 3D display format is normally recognised correctly when the factory setting **3D mode → Automatic** is selected. You may need to set the 3D mode manually to view 3D content from broadcasters.

**i** Owing to a reduction in the luminance in 3D mode for technical reasons, **Auto-dimming - Room** and **Auto-Dimming- Video (VBD+)** (see page 86) are deactivated when 3D contents is displayed.

**i** If the TV set is operated with the remote control during a 3D playback, flicker effects can occur in the 3D glasses when doing this.

**i** For playback of movies in 3D mode we recommend to disable the LED backlighting <sup>1</sup> (see pages 19 and 110).

### Calling 3D settings

HOME

**HOME:** Call **Home** view.



◀ ▶ ▲ ▼ Mark **System settings**,  
**OK** call System settings.

▼ ▲ Mark **Picture**,  
▶ go to next column.

◀ ▶ Mark **3D**,  
▶ go to next column.

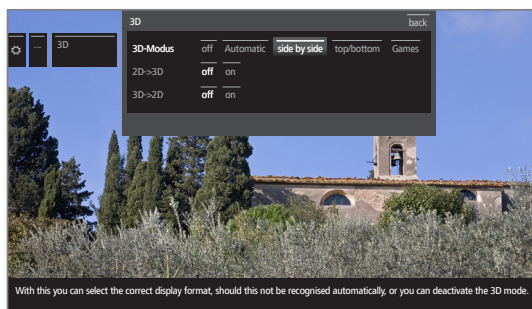

◀ ▶ ▲ ▼ Select settings,  
**OK** adopt.

### Explanations of the 3D settings:

#### 3D Mode

off Here you can deactivate the 3D mode of the TV set. The TV set shows the 2D/3D image material in the same way as it is provided by the station or external player.

Automatic If the TV is set to this setting (factory setting), then the TV set automatically switches over to the correct 3D mode, if this is possible and supported by the broadcaster. Only change the setting if the 3D content is not displayed correctly.

side by side To display 3D content in **side by side** format. When viewing 3D content with this setting, two almost identical images are displayed **next to each other** and put together correctly by the TV set.

**i** The 3D mode is **automatically** reset the next time you switch on the TV set.

top/bottom To display 3D content in **top/bottom** format. When viewing 3D content with this option, two almost identical images are displayed **one above the other** and put together correctly by the TV set.

**i** The 3D mode is **automatically** reset the next time you switch on the TV set.

Games To display 3D content in **full picture** format. When viewing 3D content with this option, two almost identical images are displayed as **full pictures** and put together correctly by the TV set.

**i** The 3D mode is **automatically** reset the next time you switch on the TV set.

#### 2D->3D

on/off If you set 2D->3D to **on**, all 2D image material will be displayed in 3D. You will need to wear the 3D glasses to view it properly.

#### 3D->2D

on/off If you set 3D->2D to **on**, the 3D material from TV stations as well as from external players will be changed into 2D and played back. The three dimensional (3D) effect will disappear. You will not need to wear the 3D glasses to view it properly.

<sup>1</sup> Depending on the type of TV set.



### Picture format / 3D mode

If 3D contents are recognised by the TV device, the picture format cannot be subsequently changed. The picture format when in 3D operation is always 16:9 PC.

### Instruction / Symbol

If 3D content is detected by the TV set, a corresponding message appears. The instruction text will disappear after the display time has elapsed (see also page 101).



In the status display, 3D content is indicated by an icon.



## Sound

### Calling the sound settings

The selectable menu items depend on the selected station and the connected sound components.

HOME

**HOME:** Call **Home** view.



◀ ▶ ▲ ▼ Mark **System settings**,  
**OK** call System settings.

▼ ▲ Mark **Sound**,  
▶ go to next column.

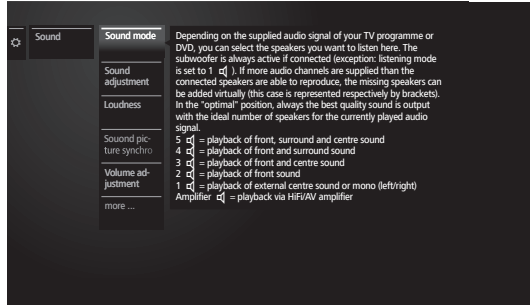

▲ ▼ Select sound function,  
▶ proceed to next column.

### Explanations of the sound settings:

**Sound mode** Select the number of speakers you want to hear. The selection depends on the connected sound components (starting from page 119) and on the transmitted audio signal.

If the number of speakers appears in brackets, the sound of missing speakers is transmitted by the existing speakers (virtually).

**Optimum** The momentarily reproduced audio signal is output with the ideal number of speakers.

- 1 Play centre sound or mono (left/right).
- 2 Play front sound (L/R stereo).
- 3 Play front and centre sound.
- 4 Play front and surround sound.
- 5 Play front, surround and centre sound.

**HiFi/AV amplifier** Play via an external HiFi amplifier. Selection is only possible if an amplifier has been selected in the sound components wizard (see page 122).

**Dolby PLII mode** Here you can make Dolby Pro Logic II sound settings for movie and music.

Menu item only appears with certain sound mode settings.

**Sound adjustment** Here, you can adapt preset sound characteristics of the respective broadcast. Selectable are, e.g., Speech, Classical, Pop, Custom music and Film soundtracks. For personal music and film sound you can do the settings for pitch and bass sound (high and low frequencies).

**Loudness** Proper boost of bass and treble tones at low volume.

### Explanations of the sound settings (continued):

**Sound picture synchronisation** If the sound and picture are not precisely in sync, you may correct this here. Move the mark on the bar downwards, slowing down the sound compared with the picture. Move the mark upwards, speeding it up compared with the picture. Time adjustment of the sound occurs in steps of 10 ms in each case.

only available for DVB stations.

**Volume adjustment** The volume can differ according to the individual stations. If the sound is too loud or too quiet in relation to other stations, adjust the volume. When the menu is open, you can select the stations one after another with **P+ / P-** and adjust every single station conveniently.

**more ...** call with **OK**.

**Loudspeaker/ Headphone sound** Selection options for Mono/ Stereo or Sound 1 or Sound 2 for bilingual programmes, separately for the loudspeakers and the headphones.

only available for analogue stations.

**Auto volume** The volume may vary when receiving stations with different standards, when switching from station to station or during commercials.

You can reduce these differences in volume by selecting auto volume **on**. For music and live broadcasts you get a better sound spectrum with auto volume **off**.

**AV output signal** You can indicate here which sound is output via the AV socket for dual sound programmes: Sound 1 (e.g. main language), sound 2 (e.g. foreign language), or sound 1+2 (both simultaneously).

**Maximum volume** You can limit the volume adjustment of the loudspeakers. This prevents selecting a volume which is too loud.

**Maximum switch on volume** Set the sound level to be heard after switching on the TV set with the mains switch or after a power failure. When switching on the TV set in standby mode, the volume last used is retained unless it was above this switch-on level. Otherwise it is limited by this.

**Balance** Set stereo balance so that the volume impression is identical on the left and right.

**Auto speech detection** If the automatic speech detection is activated, the sound of the current programme is automatically output with optimum comprehensibility when speech is detected.

## Stations

Under the item "station" you find all settings concerned with station search for TV and DVB radio as well as functions for creating and editing the various station lists.

**i** Station management is not possible as long as a programmed timer recording is active.

**i** If at least one station is locked, the access code must be entered prior to automatic search (see **Parental lock** on page 100).

**i** The procedure for radio stations or Station lists Radio is similar to that for TV stations or Station lists TV. Therefore, this procedure is described only for TV stations.

### Call Stations menu

HOME

**HOME:** Call **Home** view.



◀ ▶ ▲ ▼ Mark **System settings**.

**OK** call System settings.

▼ ▲ Mark **Stations**.

▶ go to next column.

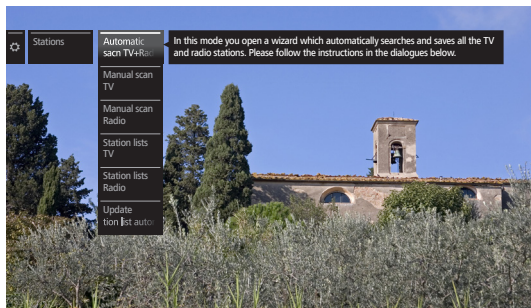

▲ ▼ Select desired function,

▶ proceed to next column.

### Explanations of setting possibilities in the Stations menu:

Automatic scan TV+Radio Here you start the wizard that searches and stores all TV and DVB radio stations (starting from page 92).

Manual scan TV Here, you can enter all the settings available for a TV station. (see page 93).

Manual scan Radio Here, you can enter all the settings available for a DVB radio station. (see page 93).

Station lists TV Here you can move and delete TV stations in all lists. You can put together your most frequently watched programmes in one or more lists of personal favourites (see page 95).

Station lists Radio Here you can move and delete DVB radio stations in all lists. You can put together your most frequently watched programmes in one or more lists of personal favourites (see page 95).

Update station list automatically If the channel list is not up to date, it will be updated automatically, provided the parameter **Allow** is selected (see page 97).



## Automatic scan TV+Radio

For automatic scan TV+Radio, a search wizard will be started that searches for new stations which are not yet stored.

- I** You have to repeat the initial installation (see page 83) and automatically search for new stations if you want to delete all the existing stations and automatically search for new ones.

HOME



**HOME:** Call **Home** view.

- ▼ ▲ Mark **System settings**.
- OK** call System settings.

- ▼ ▲ Mark **Stations**.
- ▶ go to next column.

- ▼ ▲ Mark **Automatic scan TV+Radio**.
- ▶ go to next column.

In the upper info text the current search settings will now be displayed:

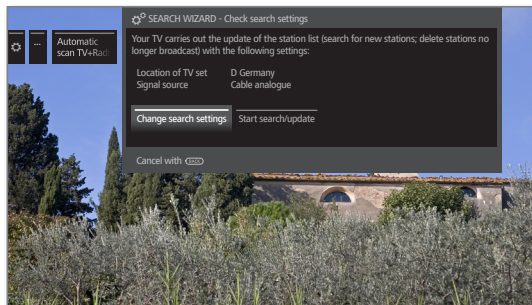

If you want to change these search settings:



- ◀ ▶ Select **Change search settings**.
- OK** wizard guides you through the search settings (see column on the right).

If you agree with these settings:

- ◀ ▶ Select **Start search/update**.
  - OK** start scan.
- See page 93 to continue after the search operation.

BACK

**BACK:** Cancel current search/update.

### Explanations of some search settings:

- Age-related lock** You can specify an age limit for your TV set here. DVB broadcasts that have an appropriate age identification are locked and can only be watched after entering the access code.
- Signal source** Select antenna/cable (analogue), DVB-T, DVB-C or DVB-S depending on which signal source you want to search for new stations.
- Cable (analogue) TV/colour standard** With the selection of TV set location the conventional TV standard/colour standard is the default. This should only be changed if stations with other standards are to be searched.
- DVB-T/C/S Network selection** If several networks are available, you can decide which network you want to receive your channels from.

### Explanations of some search settings (continued):

- DVB-T/C/S Settings** With the selection of set location the conventional settings will also be preset. Only change these defaults if you are familiar with other parameters.

#### Scrambled stations: (DVB-T/C/S)

You can state whether scrambled stations are to be searched for in the search/update. If you select **yes**, coded stations will also be searched for. However, these stations can only be received in connection with a CA module and the appropriate Smart Card. Ask your dealer which Smart Card you need to receive certain stations. Handling of the CA module is described on page 81.

#### Search method: (DVB-T)

If you want to run the station search independently of the channel grid, select **Frequency search** for the search method.

#### Search method: (DVB-C)

If you select **Frequency search** here, a search is performed for all receivable stations. With **Network search**, only the stations which the networks supply are searched - either for all receivable networks or only for the particular network specified under **Network ID**.

#### Network ID: (DVB-C)

If you select **none** here, DVB signals of all current broadcasting networks are scanned automatically (recommended for most cable networks). If, on the other hand, you specify a certain network ID (necessary in the cable networks of some countries), only DVB signals of this broadcasting network are searched for automatically. Your cable provider has the information you need.

#### Search method: (DVB-S)

If you select **Frequency search** here, a search is performed for all receivable stations. With **Network search**, from all receivable networks all the stations are searched which are supplied by these networks.

#### Accept Logical Channel Number: (DVB-T/C/S)

In various countries, digital stations (DVB-T/C/S) are transmitted with a preset channel number per station, known as Logical Channel Numbers (LCN). If you select **yes** here, these default channel slots will be used and the channels of the preferred signal source will be sorted as per LCN. The stations in the station list can no longer be shifted (see **Move block / Change order** on page 95).

## Search for/update stations – handling of new and no longer found stations

The number of new TV stations found is displayed after the automatic search / update has been completed.

 Proceed. The number of new radio stations found is displayed.

 Call list of new TV stations found.



 Select station.  
**OK** Mark / unmark station.

 stores the marked TV stations. The list of new radio stations found is displayed.

 Select station.  
**OK** Mark / unmark station.

 Proceed.

Afterwards, a list of the stations which are saved but which are temporarily not broadcasting or no longer exist is displayed, if available.

The number of the memory location used is displayed in front of the station. Please select the stations you really want to delete.

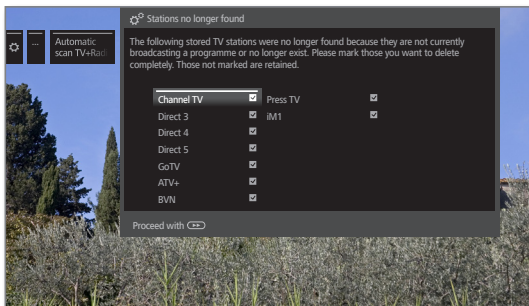

 Select station.  
**OK** Mark / unmark station.

 Proceed. The marked stations will be deleted. The list of radio stations no longer found is displayed.

 Select station.  
**OK** Mark / unmark station.

 End search wizard.

## Manual Scan TV / Radio

Here, you can enter all the settings available for a station. However, this requires detailed knowledge.

**i** The manual search of radio stations is similar to that of TV stations. Therefore, the manual search for radio station is not dealt with separately.

### Calling manual search

 **HOME:** Call Home view.

 Mark **System settings**.  
**OK** call System settings.

▼ ▲ Mark **Stations**.  
▶ go to next column.

▼ ▲ Mark **Manual Scan TV**.  
**OK** call Manual Scan.

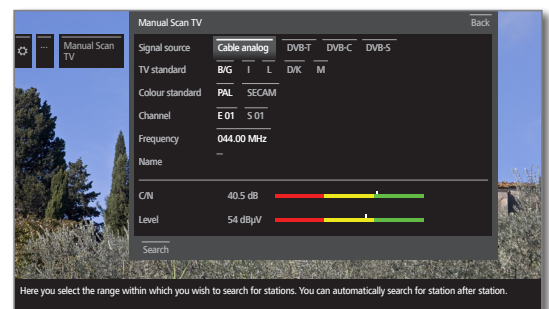

Select the menu item **Signal source** to decide in which area you want to search for stations.

Depending on the selected source, various setting possibilities will be available.

On the next page, the settings for analogue cable and DVB-T/C/S sources are described separately.

### Status bar for manual search

Status bars are displayed for manual search, which show the reception quality of the individual stations during the station scan. The markers in all bars should preferably be in the green area.

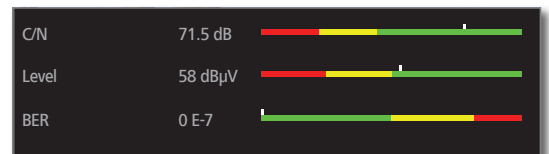

**C/N:** (Carrier/Noise) The bar shows the signal-to-noise ratio. The value indicated in dB should be preferably high.

**Level:** The bar shows the receiving level of the station. The value displayed in dBµV should be preferably high.

**BER:** (Bit Error Rate) The bar shows the bit error rate of the station. The value for BER should be as low as possible.

### Manual search for cable analogue (analogue cable reception):

- i** Manual search is called.
- i** **Cable analogue** has been selected as signal source.

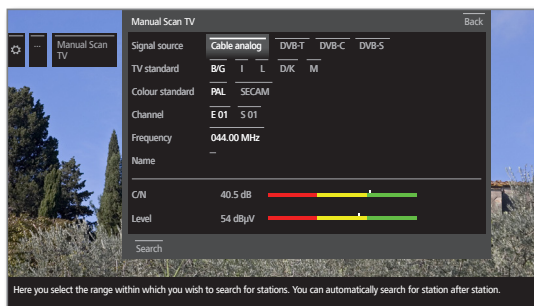

▲ ▼ ◀ ▶ Mark and adjust settings,  
**OK** confirm as the case may be.

▲ ▼ ◀ ▶ Mark Search,  
**OK** start search.

If a station has been found:

▲ ▼ ◀ ▶ Mark **Store/Overwrite**,  
**OK** store station.

### Explanations on the search settings for cable analogue:

Signal source	Selection of range in which you want to search for the station.
TV standard	If necessary, ask your dealer which standard to select for specific channels or AV equipment.
Colour standard	If necessary, ask your dealer which standard to select for specific channels or AV equipment.
Channel	Direct input of channel.
Frequency	Direct input of station frequency. Range for entry: 044.75 MHz - 859.25 MHz.
Name	Here, the name of the found station is displayed. You can change the name of the station. For the entry of characters see page 17.

### Manual DVB-T/C/S search:

- i** Manual search is called.



▲ ▼ ◀ ▶ Mark and adjust settings,  
**OK** confirm as the case may be.

▲ ▼ ◀ ▶ Mark Search,  
**OK** start search.

When a DVB transponder has been found:

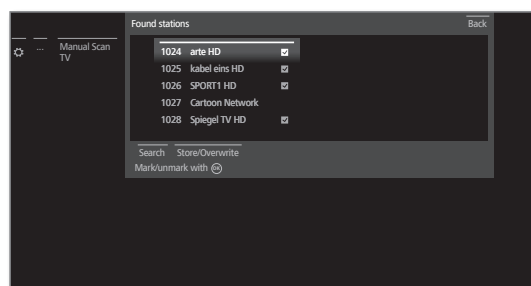

▲ ▼ ◀ ▶ Mark the station,  
**OK** Station will be ticked with . If necessary, repeat for several stations.

**i** Stations that already exist in the station overview will be displayed with their station number on the left.

▲ ▼ ◀ ▶ Mark **Store/Overwrite**,  
**OK** Stations marked with  will be stored.

### Explanations of some search settings:

<b>Signal source</b> (DVB-T/C/S)	Selection of range in which you want to search for the station.
<b>Channel</b> (DVB-T)	Direct input of channel.
<b>Satellite</b> (DVB-S)	Here you can select the satellite where the stations are to be searched for.
<b>Band</b> (DVB-S)	Here you can select the frequency band in which shall be searched. Setting ranges:   horiz/low  10694 - 11906 MHz horiz/high 11544 - 12756 MHz vert/low   10694 - 11906 MHz vert/high  11544 - 12756 MHz
<b>Frequency</b> (DVB-T/C/S)	DVB-T/C: Direct input of station frequency. DVB-S: Direct input of LNC frequency
<b>Symbol rate</b> (DVB-S)	Here you can specify the symbol rate Range: 1000-45000



## Station lists TV / Radio

Under the menu item **Station lists TV** or **Station lists Radio** you can edit (delete block, move block, restore deleted stations) various lists, e.g., **DVB-T**, **DVB-C**, etc. You can also create and edit new **Personal lists** (see page 96).

**i** The function of Station lists Radio is similar to that of Station lists TV. Therefore, editing of Station lists Radio will not be dealt with separately.

### Change overall station list

**i** If at least one station is locked, the access code must be entered before changing stations (see Parental lock on page 100).

HOME

**HOME:** Call **Home** view.



▼ ▲ Mark **System settings**,  
**OK** call System settings.

▼ ▲ Mark **Stations**,  
▶ go to next column.

▼ ▲ Select **Station lists TV**,  
▶ go to next column.

▼ ▲ Mark **Overall station list**,  
▶ call list.

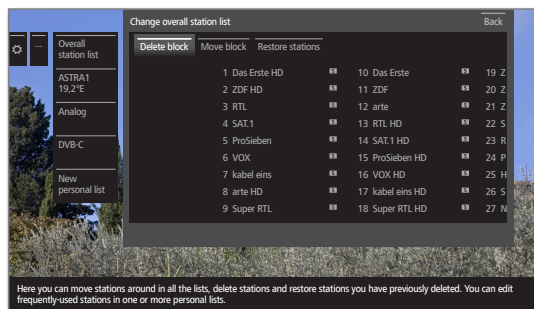

Here, you can delete and move station blocks as well as restore deleted stations.

The following section describes how to proceed if you wish to **Delete block**, **Move block** and **Restore stations**.

### Delete block



◀ ▶ ▲ ▼ Select **Delete Block**,  
▼ move to list.

◀ ▶ ▲ ▼ Select beginning of block,  
**OK** mark beginning of block.

◀ ▶ ▲ ▼ Select end of block,  
**OK** mark end of block (selected stations are coloured blue).

◀ ▶ ▲ ▼ Select **Execute delete**,  
**OK** block will be deleted, or

◀ ▶ ▲ ▼ select **Cancel procedure**,  
**OK** cancel delete.

### Move block / Change order

**i** Stations with LCN cannot be reordered. In this case, the function **Move block** is hidden.



◀ ▶ ▲ ▼ Select **Move block**,  
▼ move to list.

◀ ▶ ▲ ▼ Select beginning of block,  
**OK** mark beginning of block.

◀ ▶ ▲ ▼ Select end of block,  
**OK** mark end of block (selected stations are coloured blue).

◀ ▶ ▲ ▼ Select insert position,  
**OK** Confirm insert position.

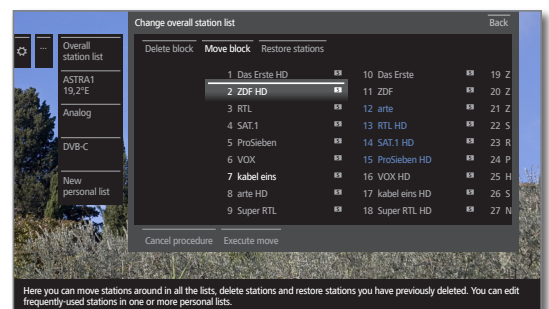

◀ ▶ ▲ ▼ Select **Execute move**,  
**OK** block will be moved, or

◀ ▶ ▲ ▼ select **Cancel procedure**,  
**OK** cancel move.

### Restore stations



◀ ▶ ▲ ▼ Select **Restore stations**,  
▼ move to list.

◀ ▶ ▲ ▼ Select beginning of block,  
**OK** mark beginning of block.

◀ ▶ ▲ ▼ Select end of block,  
**OK** mark end of block (selected stations are coloured blue).

◀ ▶ ▲ ▼ Select **Restore stations**,  
**OK** stations will be added again to the station list, or

◀ ▶ ▲ ▼ select **Cancel procedure**,  
**OK** cancel restore.





## Compose / edit Personal list

Each personal list can contain up to 99 stations. You can compose the personal lists to suit your convenience (e.g., topic lists). Other persons using this TV set can create their own personal lists. You can create up to six personal lists.

**i** Creating and updating personal station lists is not possible as long as a programmed timer recording is active.

### Create / edit New personal list

HOME

**HOME:** Call **Home** view.



▼ ▲ Mark **System settings**.  
**OK** call System settings.

▼ ▲ Mark **Stations**.  
▶ go to next column.

▼ ▲ Mark **Station lists TV**.  
▶ go to next column.

▼ ▲ Mark **New personal list**.  
**OK** New personal list x will be created.

**i** . The number depends on how many list were already created.

▼ ▲ Mark **Personal list x**.  
▶ Open Personal list x (list does not contain any stations yet).  
▶ Open function list.

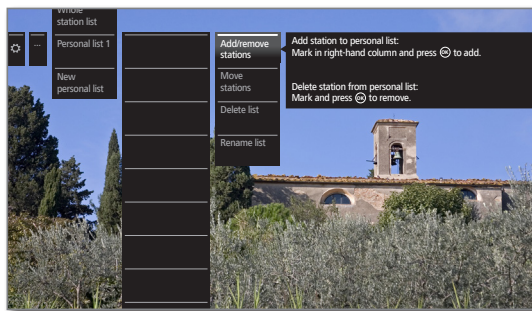

### Renaming the Personal list

**i** The Personal list to be renamed must be opened.



▼ ▲ Select **Rename list** in the function list,  
**OK** activate.

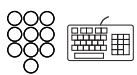

Enter new station (same procedure as with rename station, see page 17).



◀ ▶ ▲ ▼ Select **Adopt**.  
**OK** New name for the personal list will be adopted.

### Delete Personal list

**i** The Personal list to be deleted must be opened. Deleting of the list is irrevocable.



▼ ▲ Select **Delete list** in the function list,  
**OK** activate.

## Adding stations to Personal list

**i** The Personal list must be opened to add new stations to it.



▼ ▲ Select **Add/remove Stations** in the function list,  
▶ go to next column (station list). The sorting procedure for the station list may be changed between numerical and alphabetical.  
To this end, select the selection fields **0...9** with  
▶ or call **A..Z** and confirm accordingly.

▲ ▼ Mark the station in the station list which is to be added to the personal list.

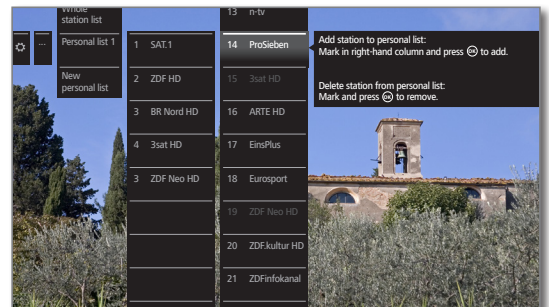

**OK** adds the station to the personal list.  
. Function of the coloured keys in standard PIP functionality.

BACK

**BACK:** Close station list.

## Deleting stations from the Personal list

**i** The Personal list must be opened to delete stations in it.



▼ ▲ Select **Add/remove Stations** in the function list,  
**OK** activate.  
▶ go to personal list.

▲ ▼ Mark the station to be deleted in the personal list,  
**OK** activate. Function of the coloured keys in standard PIP functionality.

BACK

**BACK:** Close station list.

## Move / reorder stations in the Personal list

**i** The personal list must be opened to move stations in it.



▼ ▲ Select **Move stations** in the function list,  
**OK** activate.

▲ ▼ Select station to be moved in the Personal list,  
**OK** mark (station will be coloured red).

▲ ▼ Select insert position (insert position will be marked with a red line),  
**OK** Execute move. Function of the coloured keys in standard PIP functionality.

BACK

**BACK:** Close station list.

## Update station list automatically

Some programme providers offer an automatic update of the station lists (Dynamic Channel Management). You may **Allow** or **Block** an automatic station list update. If automatic updating is allowed, a screen message about an available update appears whenever the list is changed.

### Allow/block updates

HOME

**HOME:** Call **Home** view.



▼ ▲ Mark **System settings**,  
**OK** call System settings.

▼ ▲ Mark **Stations**,  
▶ go to next column.

▼ ▲ Mark **Update station list automatically**,  
▶ go to next column.

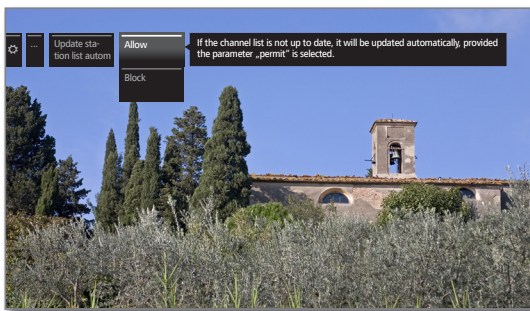

▼ ▲ Select **Allow** or **Block**,  
**OK** adopt.

If the channel list is not up to date, it will be updated automatically, provided the option **Allow** is selected.

### Updating the station list

A message appears whenever the TV is switched on if the network provider changes their channel list.

**i** In **Update station list automatically**, **Allow** must be selected.

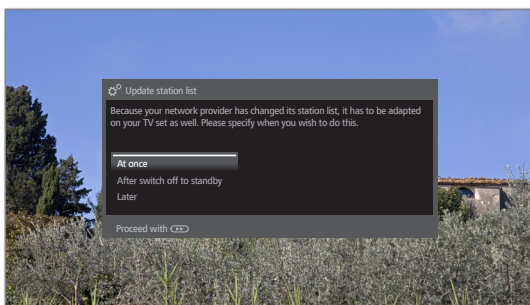

▲ ▼ Select the desired procedure.

**At once** The station list will be immediately updated. Normally this occurs in the background without interfering further with the TV's operation. In exceptional cases, it is however possible that during this process an automatic station change may be necessary.

**After switch off to standby** The channel list will be updated the next time the TV set is switched off into standby mode.

**Later** Updating the channel list will be postponed to a later date. When the TV set is switched on and off, the update message will appear again.



**OK** Confirm selection.



## Control

In the chapter Control you find settings for the various operating modes like PIP and DR+ as well as settings referring in an interfunctional way to your TV set like, for example, time and date and on-screen displays.

### Calling Control

HOME

**HOME:** Call **Home** view.



◀ ▶ ▲ ▼ Mark **System settings**.  
**OK** call System settings.

▼ ▲ Select **Control**.  
▶ go to next column.

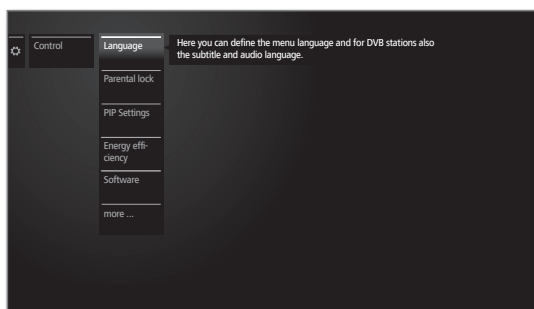

▼ ▲ Select desired menu item,  
▶ go to next column.

### Explanations of setting possibilities in the Control menu:

**Language** Here you can define the menu language and for DVB stations also the subtitle and audio language (see page 99).

**Parental lock** With the parental lock you can bar access to all stations immediately or daily for a certain period of time. The stations can also be locked individually. Age-dependent locking of programs with an appropriate age code is also possible. (see page 100).

**PIP Settings** In this menu you can make all adjustments for the picture-in-picture display (see page 99).

**Energy efficiency** Here you can determine how energy efficient your TV set shall be (see page 101).

**Software** Here you can download new software from a USB storage medium or from the Internet (as far as requirements exist for this) (see page 101).

**more ...** After confirmation with the **OK** key you will be offered additional not so frequently used sub items for the current menu item (see right hand column).

### more ...

**On-screen displays** Here you can make settings for the duration, position and existence of special on-screen displays (see page 104).

**Time and date** The time and date are normally obtained automatically from the TV. (see page 104).

**DVB settings** Here you can make settings which only refer to DVB stations (subtitles and audio mode, DVB character set), see page 105.

**EPG** Here you can do all EPG settings (see page 105).

**DR+** Here you can do all the settings for the digital recorder (see page 106).

**Standard Teletext** Here you can do all Standard Teletext settings (see page 107).

**HbbTV** Here you can do all settings for the HbbTV mode (see page 108).

**CA module(s)** Here you can allocate stations to a CA module or assign the PIN for recordings (see page 109).

**LED light module** Here, make the settings for the LED backlighting of your TV set (see page 110).

**i** Menu item will only be displayed when the TV set is equipped with an LED light module.

**Rotate TV** Here you can define the maximum range of rotation and the switch-off position for a TV set with motorized stand (see page 111).

**i** Menu item will only be displayed when a motorized stand is connected to the TV set.

**Recording** Here you can specify the lead time and follow-up time for recordings (see page 112).

**Hard disks** Here you find tools to format or check the hard disks (see page 113).

## Language

Specify the language for all menus in the TV set in the language menu. The language for the DVB subtitles and the film language can be set for DVB programmes.

### Call language

HOME

**HOME:** Call **Home** view.



◀ ▶ ▲ ▼ Mark **System settings**.

**OK** call System settings.

▼ ▲ Mark **Control**.

▶ go to next column.

▼ ▲ Mark **Language**.

▶ go to next column.

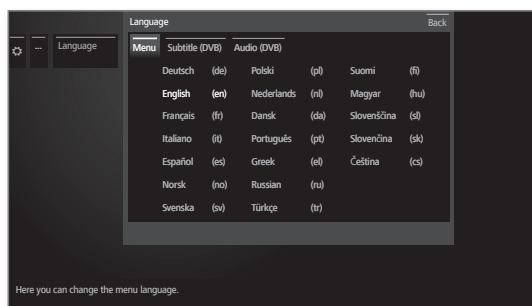

◀ ▶ ▲ ▼ Select desired setting and make changes.

**OK** Adopt settings.

### Explanations of setting possibilities in the Language menu:

**Menu** You can change the menu language here.

**Subtitle (DVB)** If subtitles are provided by the DVB station, you can set your desired language in advance here. If this is included in the range of languages of the station, it will be shown automatically.

You can also specify an alternative language under this menu item, in case your chosen language is not offered by the station.

**Audio (DVB)** Specify your desired film language in advance here. If this is included in the range of languages of the station, it will be shown automatically.

You can also specify an alternative language under this menu item, in case your chosen language is not offered by the station.

## Picture in Picture (PIP)

### Adjust size of the PIP image

HOME

**HOME:** Call **Home** view.



◀ ▶ ▲ ▼ Mark **System settings**.

**OK** call System settings.

▼ ▲ Mark **Control**.

▶ go to next column.

▼ ▲ Mark **PIP Settings**.

▶ go to next column.

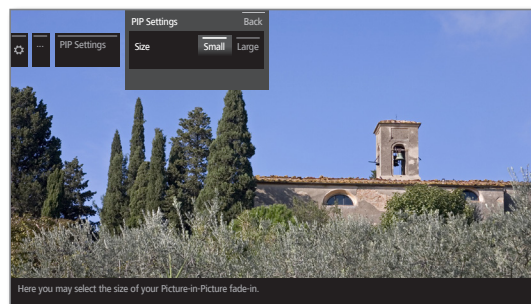

◀ ▶ ▲ ▼ Select desired setting and make changes.

**OK** Adopt settings.

### Explanations of setting possibilities in the PIP Settings menu:

**Size** You can choose if your second picture faded in (picture in picture) shall be displayed **small** or **large**.



## Parental lock

You can select and set various security options to prevent unauthorised use of the TV set and to protect your children from unsuitable programmes.

### Call Parental lock menu

HOME

**HOME: Call Home** view.



◀ ▶ ▲ ▼ Mark **System settings**,  
**OK** call System settings.

▼ ▲ Mark **Control**,  
 ▶ go to next column.

▼ ▲ Mark **Parental lock**,  
 ▶ go to next column.

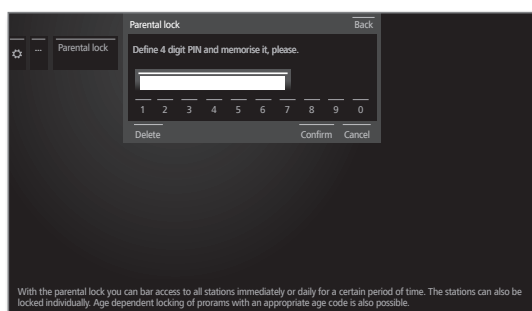

Define a four digit access code (PIN) the first time you open it. Note the access code (PIN) well.



◀ ▶ ▲ ▼ Mark **Confirm**,  
**OK** activate.

The new PIN must be entered and confirmed again.

The **Parental lock** menu will be opened.

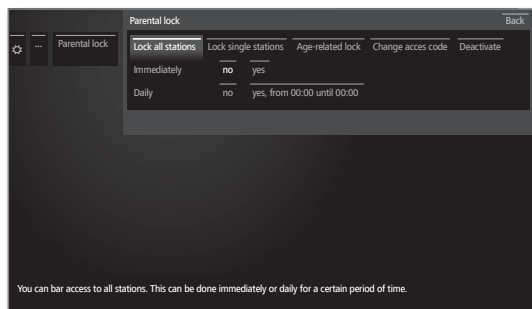

The four-digit access code (PIN) must be entered when the parental lock is opened in future. For security reasons, it appears encrypted (**\*\*\*\***) when entering.



### Explanations of setting possibilities in the Parental lock menu:

**Lock all stations** The TV set is locked immediately the menu is exited. All programmes can then only be watched after entering the access code. The lock can be activated both **Immediately** and for a **Daily** defined period. The lock remains active until it is switched off in the menu.

**Lock single stations** You can lock / unlock individual or all of the stations in the station list specifically. The lock remains active until it is switched off in the menu.

**Age-related lock** Some DVB stations also broadcast an age classification. If the age set here is below the broadcast age limit, the programme can only be watched after entering the access code.

**Change access code** You can change your access code at any time. Enter the new access code in place of the old one.

**Deactivate** All set parental locks (locked stations, age-dependent locks, locked films in the DR+ archive) are cancelled. The current secret code is deleted. When the parental lock is reactivated all the previous parental locks are set again automatically.

**Reset** All currently set parental locks are finally cancelled. The access code is deleted.

### Protection of minors for CI Plus programmes

Youth-protected broadcasts of programme providers with CI Plus encoding possibly require you to enter the secret number (PIN) of the CA module.

**i** The Parental lock PIN of the CA module can be store in the TV set (see page 109).

We recommend selecting the secret number of the TV set according to the secret number of the CA module, since the secret number of the CA module cannot be changed. This means that you must only remember one secret number.

### Code number

The code number cancels all entered PINs. It can be used for example if you have forgotten your PIN. On page 143 you find a note on the access code number. Remove this from the manual and keep it in a safe place.

### Note for unlocking

As soon as the PIN has once been entered to unlock your TV set, all currently set parental locks will be disabled temporarily. Besides of the general locks described in this chapter, this is also valid for parental lock of DR+ archive entries. Parental locks will only be re-enabled when the TV set is switched off.

## Energy efficiency

Determine how energy efficient your TV set shall be. The value for the contrast (and thus the brightness of the background lighting) is adapted and the automatic dimmer activated or deactivated (see page 86) depending on the presetting.

### Call Energy efficiency

HOME

**HOME:** Call **Home** view.



◀ ▶ ▲ ▼ Mark **System settings**,  
**OK** call System settings.

▼ ▲ Mark **Control**,  
▶ go to next column.

▼ ▲ Mark **Energy efficiency**,  
▶ go to next column.



◀ ▶ ▲ ▼ Select desired setting and make changes.  
**OK** Adopt settings.

### Explanations of the setting options in the energy efficiency menu:

Choosing **Home Mode** activates automatic shutdown. For **Premium Mode** or **Shop Mode**, automatic shutdown is initially deactivated. See page 6 for further information on automatic shutdown.

Home Mode	The emphasis for home use is on low energy consumption. The automatic dimmer is activated.
Premium Mode	This mode optimises the settings to a brighter environment at a higher energy consumption. The automatic dimmer is activated. The use of this energy efficiency setting must be confirmed afterwards once again.
Shop Mode	The picture settings are aligned to operation in the presentation room. The automatic dimmer is deactivated. If the ambient brightness diminishes, the energy consumption is not reduced. The use of this energy efficiency setting must be confirmed afterwards once again.

## Software update

It is possible to update the software on your Loewe TV set.

In the software update (package update) all the software releases in the TV are scanned and updated as required.

Here you can download a new piece of software from different sources (if existing):

Current software versions can be downloaded from the Loewe Internet site (see below) and installed on your TV set using a USB stick (see page 102).

**i** Please be aware of the requirements of your USB stick on page 143.

If your TV set is connected to the Internet, the TV set can be updated directly via the Internet (see page 103).

### Software download from the Loewe Internet site for update via USB

Where available, you can download new software for your TV set from our homepage.

Visit our homepage under:

**<http://support.loewe.tv>** (International),  
**<http://support.loewe.tv/uk>** (United Kingdom and Republic of Ireland),  
**<http://support.loewe.tv/au>** (Australia) or  
**<http://support.loewe.tv/nz>** (New Zealand).

(using the **Register free-of-charge** option).

Simply follow the steps in the registration process.

After the successful registration process and subsequent login to the support homepage you have to register your TV set (have the article number and serial number ready – both of these are on a label stuck to the back of the set or can be looked up under **Integrated features**, see page 83).

Then you will get a list of downloadable contents for your TV set including the software. Download the data and unpack all the files in this ZIP archive into the main directory of your USB stick.

Then carry out the software update as described below.



## Software update via USB storage device

To do this, plug the USB stick with the downloaded software (see page 101) into a free USB port of the TV set (see connections page 11).

### Calling Software update

HOME

**HOME:** Call **Home** view.



◀ ▶ ▲ ▼ Mark **System settings**.  
**OK** call System settings.

▼ ▲ Mark **Control**.  
▶ go to next column.

▼ ▲ Mark **Software**.  
▶ go to next column.

▼ ▲ Mark **Software update**.  
▶ go to next column.

▼ ▲ Mark **Via USB**.  
▶ call Software update.  
The version of the software package that is currently installed will be displayed.

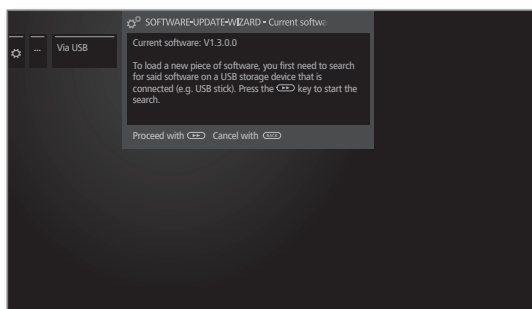

▶▶

▶▶ **Proceed.**

The TV set searches for a new software package on the USB stick.

If a new software version is available after the search, an on-screen message appears (see right hand column).

If several different software packages are found on the USB stick, the latest software package is always used.

If no new software package was found in the search:

BACK

**BACK: End of wizard.**

### New software package found

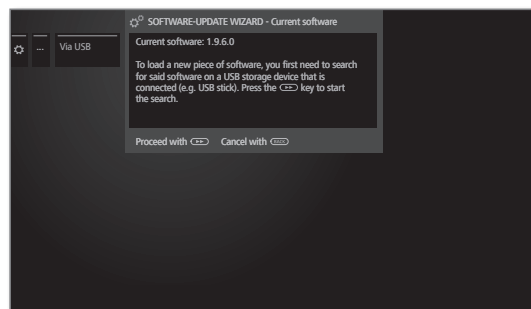

▶▶

▶▶ **Proceed** starts loading of the new software.

Or:

BACK

**BACK: End of wizard.**

The update will then **not** be carried out.

### Load new software package

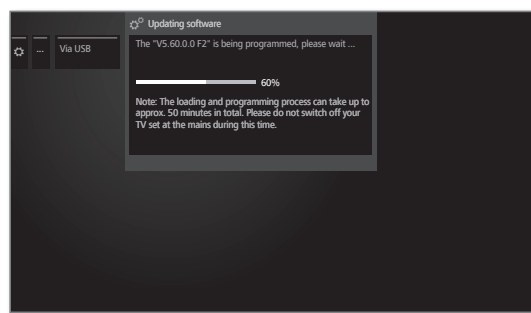

The software is loaded in several steps. The total loading and programming process can take up to approx. 50 minutes in total.

Please do **not** switch off your TV set with the mains switch during the entire loading and programming process.

You will be informed at the end of the update. To make your TV set completely ready for use again, please turn it off and on again at the mains.



## Manual update via the Internet

If an Internet connection is available, new software can be downloaded directly and installed onto the TV set.

### Calling Software update

HOME

**HOME:** Call **Home** view.



◀ ▶ ▲ ▼ Mark **System settings**.  
**OK** call System settings.

▼ ▲ Mark **Control**.  
▶ go to next column.

▼ ▲ Mark **Software**.  
▶ go to next column.

▼ ▲ Mark **Software update**.  
▶ go to next column.

▼ ▲ Mark **Via Internet**.  
▶ go to next column.  
You will see a message on the screen regarding data protection.

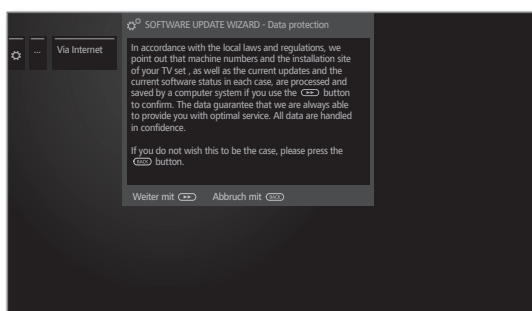

If you are not in agreement with the relevant data being passed on:

BACK

**BACK:** Exit the update process.  
The update will then **not** be carried out.



Otherwise: Confirm data protection message by pressing ▶▶.

The version of the software package that is currently installed will be displayed.

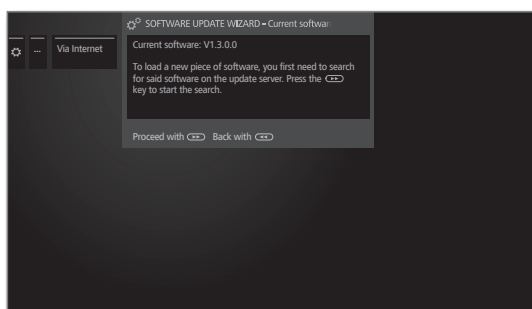

▶▶ **Proceed.**

The TV set connects to the Internet and scans the update server for new software.

If a new software version is available after the search, an on-screen message appears (see right hand column).

If no new software package was found in the search:

BACK

**BACK: End of wizard.**

### New software package found

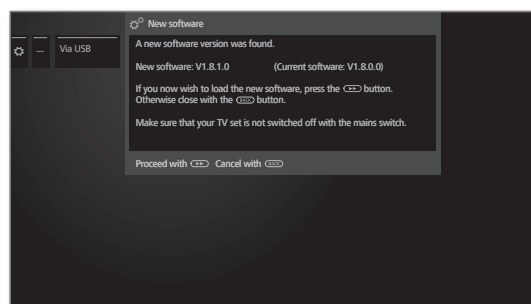

▶▶ **Proceed** starts loading of the new software.

Or:



**BACK: End of wizard.**  
The update will then **not** be carried out.

### Load new software package

Only the parts of the software package that are not up to date will be automatically downloaded from the Internet and updated.

Each part of the software is downloaded individually from the Internet and is then programmed.

The total time required for all the software parts to be downloaded from the Internet is dependent on the speed of data transfer that is being used.

The total programming process can take up to 50 minutes in total.

Please do **not** switch off your TV set with the mains switch during the entire loading and programming process.

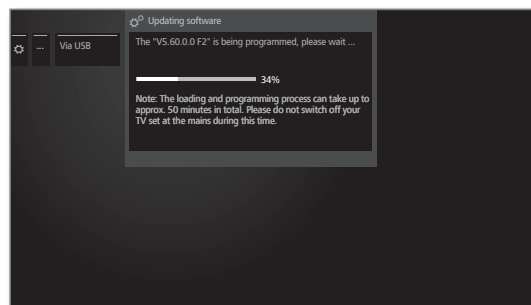

You will be informed once the loading and programming process is complete.

To make your TV set completely ready for use again, please turn it off and on again at the mains.

## On-screen displays

You can select different settings in this menu which affect the on-screen displays.

### Call On-screen displays

HOME

**HOME:** Call **Home** view.



◀ ▶ ▲ ▼ Mark **System settings**.

**OK** call System settings.

▼ ▲ Mark **Control**.

▶ go to next column.

▼ ▲ Mark **more ...**.

▶ call other settings.

▼ ▲ Mark **On-screen displays**.

▶ go to next column.

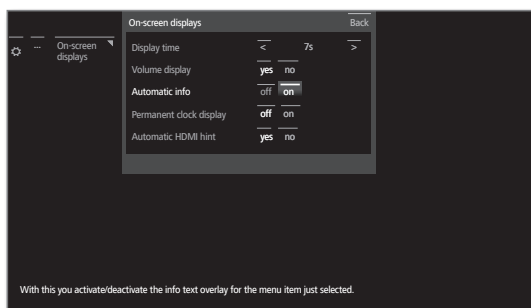

◀ ▶ ▲ ▼ Select desired setting and make changes.

**OK** Adopt settings.

### Explanations of setting possibilities in the On-screen displays menu:

Display time	Here you set the duration of the display, e.g. for the volume or the station display when changing stations. The duration can be set between 2 and 9 seconds.
Volume display	Here you set whether a volume change is also to be indicated visibly on the screen.
Automatic info	Herewith you activate/deactivate the info text displays for the currently selected menu item.
Permanent clock display	The time display can be permanently shown. It is always visible as long as no other display is made.
Automatic HDMI hint	If <b>yes</b> is set here, a message about the adapted function of the remote control is shown whenever you switch over to an HDMI channel position to which a <b>Digital Link HD</b> capable TV set is connected (see also page 124).

## Time and date

Time and date are automatically detected and set via the DVB programme provider (e.g. Astra, UPC) or, during an Internet connection, via Internet time services.

**i** If a definite time has been detected by the TV set (depending on the programme provider), time and date cannot be changed.

### Call Time and date

HOME

**HOME:** Call **Home** view.



◀ ▶ ▲ ▼ Mark **System settings**.

**OK** call System settings.

▼ ▲ Mark **Control**.

▶ go to next column.

▼ ▲ Mark **more ...**.

▶ call other settings.

▼ ▲ Mark **Time and date**.

▶ go to next column.

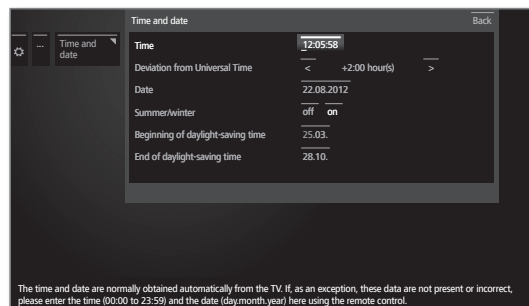

◀ ▶ ▲ ▼ Select desired setting and make changes.

**OK** Adopt settings.

### Explanations of setting possibilities in the Time and date menu:

Time	Enter the time (00:00 to 23:59) with the numeric buttons of the remote control.
Deviation from Universal Time	The current time at the Greenwich Meridian 0 is to be understood as world time. The time shift in relation to this time must be given in hours (-11 to +13) (with the keys ◀ ▶ or the numerical keys of the remote control). Summer time is ignored.
Date	Enter the date (day.month.year) with the numeric buttons on the remote control.
Summer/winter	If the summer time in your country is changed to Daylight-saving time, select <b>yes</b> please.
Beginning of daylight-saving time	Enter the date on which the time is switched over to summer time if it deviates from the automatically calculated date. This menu item appears only if <b>yes</b> was selected for Daylight-saving time.
End of daylight-saving time	Enter the date on which the summer time ends if it deviates from the automatically calculated date. This menu item appears only if <b>yes</b> was selected for Daylight-saving time.

## DVB settings

You can make general pre-settings for DVB stations.

### Calling DVB settings

HOME

**HOME:** Call **Home** view.



◀ ▶ ▲ ▼ Mark **System settings**,  
**OK** call System settings.

▼ ▲ Mark **Control**,  
▶ go to next column.

▼ ▲ Mark **more ...**,  
▶ call other settings.

▼ ▲ Mark **DVB settings**,  
▶ go to next column.

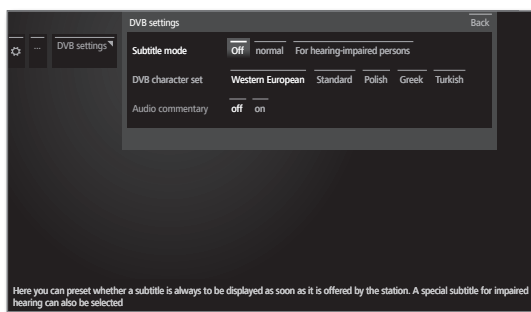

### Explanation of the DVB setting options:

Subtitle mode	Here you can preset whether a subtitle is always to be displayed as soon as it is offered by the station. A special subtitle for impaired hearing can also be selected. Subtitles are not offered by all stations. Many stations only broadcast subtitles by teletext.
DVB character set	Select the DVB character set so that the title of the broadcast of your favourite received station or the texts of your CA module are displayed correctly.
Audio commentary	You can preset the system here to always play a special soundtrack for the visually impaired whenever one is available. This soundtrack uses an audio commentary to describe the action taking place on-screen.

## EPG

### Calling EPG settings

HOME

**HOME:** Call **Home** view.



◀ ▶ ▲ ▼ Mark **System settings**,  
**OK** call System settings.

▼ ▲ Mark **Control**,  
▶ go to next column.

▼ ▲ Mark **more ...**,  
▶ call other settings.

▼ ▲ Mark **EPG**,  
▶ go to next column.

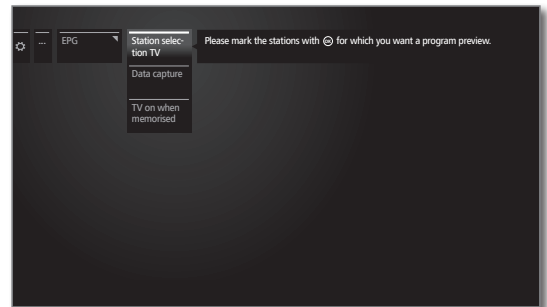

### Explanation of the EPG setting options:

Station selection TV	In the <b>Station selection</b> you can determine for which station in the programme guide, information is to be displayed. Programme information is only displayed for stations with <input checked="" type="checkbox"/> in the EPG list. Using the on-screen buttons in the bottom line you can mark all stations or unmark the stations or select stations from specific (e.g., personal) lists. Due to the large number of receivable stations you should restrict the station selection. This reduces the data entry time and increases the clarity in the EPG.
Station selection Radio	
Data capture	Here you can switch the data entry for the electronic programme guide (EPG) on and off. If the data capture is switched on, your TV set tries to update the database overnight (normally between 2 and 5 am) or, if required, two minutes after switching to stand-by mode. The TV set must be on stand-by for this and not switched off at the mains switch. The indicator on the TV set lights blue during data capture in stand-by mode. The data are also updated while you are watching the EPG station.
TV on when memorised	When <b>yes</b> is selected in the setting, the switched off TV switches on automatically in standby mode at the beginning of a memorised programme. A screen message appears when switching on. If this is not confirmed within 5 minutes with the <b>OK key</b> , the TV switches automatically off again for safety reasons.



## DR+

You can adapt the Digital Recorder to your requirements.

### Call settings for the digital recorder

HOME

**HOME:** Call **Home** view.



◀ ▶ ▲ ▼ Mark **System settings**.  
**OK** call System settings.

▼ ▲ Mark **Control**.  
▶ go to next column.

▼ ▲ Mark **more ...**.  
▶ call other settings.

▼ ▲ Mark **DR+**.  
▶ go to next column.

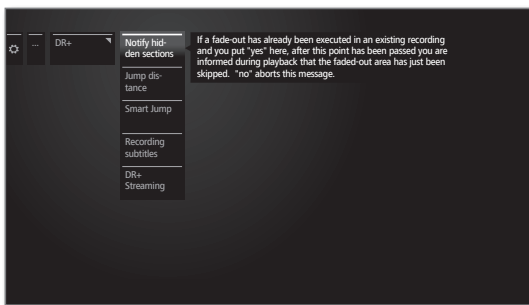

▼ ▲ Mark desired setting.  
▶ go to next column.

▼ ▲ Make settings.  
**OK** confirm setting.

### Call DR+ streaming settings

HOME

**HOME:** Call **Home** view.



◀ ▶ ▲ ▼ Mark **System settings**.  
**OK** call System settings.

▼ ▲ Mark **Control**.  
▶ go to next column.

▼ ▲ Mark **more ...**.  
▶ call other settings.

▼ ▲ Mark **DR+**.  
▶ go to next column.

▼ ▲ Mark **DR+ Streaming**.  
▶ go to next column.



▼ ▲ Mark desired setting.  
▶ go to next column.

▼ ▲ Make settings.  
**OK** confirm setting.

### Explanation of the DR+ setting options

Notify hidden sections	If an entry has been hidden in an archive recording (see page 62), you can get informed by a screen message when skipping a hidden area. Factory setting: <b>yes</b> .
Jump distance	Set the standard jump distance (in minutes) used for jumping forwards or backwards in the movie by briefly pressing the ◀◀ or ▶▶ keys. Factory setting: <b>02 min</b> .
Smart jump	Activate or deactivate Smart jump function (see page 58). Factory setting: <b>on</b> .
Recording subtitles	Select here whether subtitles are to be recorded in continuous operation for DVB stations. Factory setting: <b>no</b> <sup>1</sup> .
DR+ Streaming	For setting options see right hand column.

### Explanation of the setting options for DR+ streaming

Share DR+ archive with other devices	Specify here whether recorded broadcasts within your TV set's DR+ archive are to be accessible for viewing from other TV sets (server function). Enabled programmes can also be played on other UPnP-AV clients in the same network.
Also use other archives.	Setting yes enables you, via the archive, to also view recordings from other TV sets that have accessible movies within the home network (client function).
DR+ device name	Give your TV set a unique name for quick identification in DR+ Streaming.
DR+ device group name	Give a name for your TV set group. Using different group names enables you to group your TV sets as required. Only TV sets under the same group name can exchange data.
IP port number	IP port numbers are preset ex-factory. Under normal circumstances they do not require amending.
DR+ standby	Set here how long your TV set is to continue to give access to movies after it has been switched off. This stand-by period is also activated as soon as data exchange to another TV set has been completed.

<sup>1</sup> for devices in DK, FIN, N or S: **yes**.

## Standard Teletext

In the Teletext menu you can activate messages, reveal pages and configure the Teletext with the **Settings** menu function.

### Call Teletext settings

HOME

**HOME:** Call **Home** view.



◀ ▶ ▲ ▼ Mark **System settings**.

**OK** call System settings.

▼ ▲ Mark **Control**.

▶ go to next column.

▼ ▲ Mark **more ...**.

▶ call other settings.

▼ ▲ Mark **Standard Teletext**.

▶ go to next column.

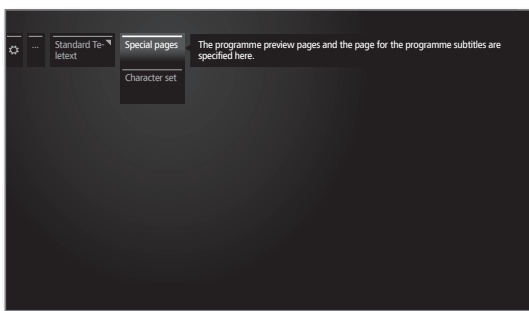

### Explanations of the Teletext menu functions:

**Special pages** Entry of the first Teletext programme preview page if this deviates from the factory setting (page 301) and enter the Teletext subtitle pages for each station if these deviate from the factory setting (page 150).

**Character set** Teletext character set can be switched to other languages (Russian, Greek, Polish and Turkish).



## HbbTV

### HbbTV mode on/off

When the HbbTV mode is active (factory setting), additional services and further information (e.g., also from the Internet) can be viewed if these are offered by the current station.

HOME

**HOME:** Call **Home** view.



◀ ▶ ▲ ▼ Mark **System settings**,  
**OK** call System settings.

▼ ▲ Mark **Control**,  
▶ go to next column.

▼ ▲ Mark **more ...**,  
▶ call other settings.

▼ ▲ Mark **HbbTV**,  
▶ go to next column

▼ ▲ Mark **HbbTV mode**,  
▶ call.

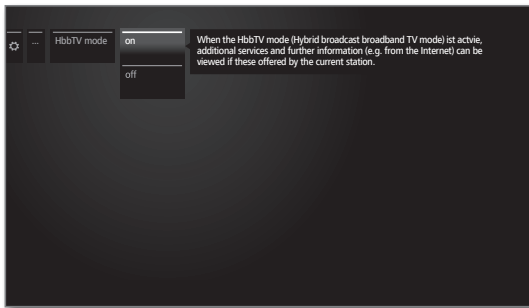

▼ ▲ Select the desired setting,  
confirm with **OK**.

### Start behaviour of HbbTV-stations

If **HbbTV mode** → **on** has been selected (see left column), you can specify if an available HbbTV application should be loaded **automatically** after the channel has been changed or if this should only occur **manually** after the red key has been pressed once. After loading the HbbTV application, an on screen instruction is displayed depending on the programme provider.

HOME

**HOME:** Call **Home** view.



◀ ▶ ▲ ▼ Mark **System settings**,  
**OK** call System settings.

▼ ▲ Mark **Control**,  
▶ go to next column.

▼ ▲ Mark **more ...**,  
▶ call other settings.

▼ ▲ Mark **HbbTV**,  
▶ go to next column

▼ ▲ Mark **Start behaviour of HbbTV**,  
▶ call.

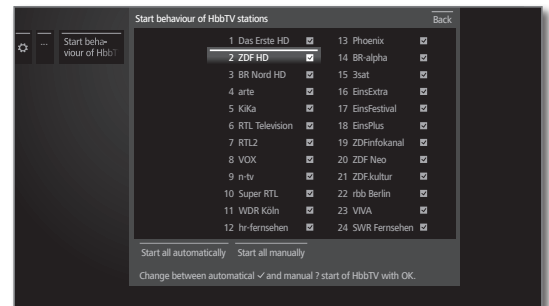

◀ ▶ ▲ ▼ Mark station,  
**OK** switch between manual (?) and automatic (✓)  
start of the HbbTV application of the marked  
station.

Or:



◀ ▶ ▲ ▼ Mark **Start all automatically**,  
**OK** start HbbTV application on all stations auto-  
matically.

Or:



◀ ▶ ▲ ▼ Mark **Start all manually**,  
**OK** start HbbTV application on all stations manually.

## Feature of the TEXT key

With the setting **Standard Teletext first** (factory setting), the standard Teletext is opened when the **TEXT key** is pressed for the first time. Pressing the **TEXT key** for a second time will then display the MediaText. Pressing the **TEXT key** for a third time will bring you back to the TV picture. If **MediaText first** is selected, the **TEXT key** will do the exact opposite.

**i** Depending on the programme provider, the direct Call of MediaText may not be possible. MediaText must then be opened by means of the HbbTV application.



**HOME:** Call **Home** view.



◀ ▶ ▲ ▼ Mark **System settings**.  
**OK** call System settings.

▼ ▲ Mark **Control**,  
▶ go to next column.

▼ ▲ Mark **more ...**,  
▶ call other settings.

▼ ▲ Mark **HbbTV**,  
▶ go to next column

▼ ▲ Mark **Function of the TEXT key**,  
▶ call.



◀ ▶ Select **Standard Teletext first** or **MediaText first**.

## CA module(s)

**i** This menu is only available when at least one CA module is plugged in.



**HOME:** Call **Home** view.



◀ ▶ ▲ ▼ Mark **System settings**.  
**OK** call System settings.

▼ ▲ Mark **Control**,  
▶ go to next column.

▼ ▲ Mark **more ...**,  
▶ call other settings.

▼ ▲ Mark **CA module(s)**,  
▶ go to next column.

## Station mapping

If two CA modules are both used for the decoding of stations, you decide here which station shall be decoded by which CA module.

**i** The station mapping settings will only be taken into account, if two CA modules are inserted.

**i** This statement refers explicitly to the CI slots of the TV set and **not** to the modules plugged into it! When the modules are exchanged, the mapping must be repeated.



▼ ▲ Mark **Station mapping**,  
▶ call station list.

◀ ▶ ▼ ▲ Select CA module for mapping.



◀ ▶ ▼ ▲ Mark the station,  
**OK** map station to the selected CA module / cancel mapping.

The icon  indicates mapped stations.

## Saving the PIN for recordings

**i** This menu item is only available if a CI Plus CA module is inserted into one of the two CI slots of the TV set that supports the recording of broadcasts with parental lock.

Store the programme provider PIN belonging to your CA module in order to decode CI plus programmes with parental lock for recording.



▼ ▲ mark **Saving the PIN for recordings**,  
▶ call PIN entry box.

◀ ▶ ▼ ▲ Mark the desired CA module in the headline.

▼ Go to the PIN entry box, enter the programme provider PIN using the numerical keys.

Or:



◀ ▶ ▼ ▲ Mark figure,  
**OK** adopt figure to input line.

Conclude the entry:



◀ ▶ ▼ ▲ Mark **Adopt**,  
**OK** save PIN.



## LED light module

Under the menu item LED light module <sup>1</sup> you make the basic settings for the LED backlighting of your TV set.

HOME

**HOME:** Call **Home** view.



◀ ▶ ▲ ▼ Mark **System settings**,  
**OK** call System settings.

▼ ▲ Mark **Control**,  
▶ go to next column.

▼ ▲ Mark **more ...**,  
▶ call other settings.

▼ ▲ Mark **LED light module**,  
▶ go to next column.



**Active time** Here you can specify whether and when the LED backlighting should be generally activated. The setting can be made both for the normal operation of the TV set as well as for the switched off TV set.  
For further information see right column.

**Luminous intensity** Determine the luminous intensity (brightness) of the LED backlighting.  
For further information see right column.

**Colour temperature** Determine the colour temperature of the LED backlighting. The negative value range stands for a rather cooler white, the positive value range makes the light appear as warm white.

**Shut-off delay** Select **yes**, if the LED backlighting shall continue to light for approx. 30 sec after the TV set is switched off.

## Determine the active time of the LED backlighting



▼ ▲ Mark **Active time**,  
▶ call settings for the active time.

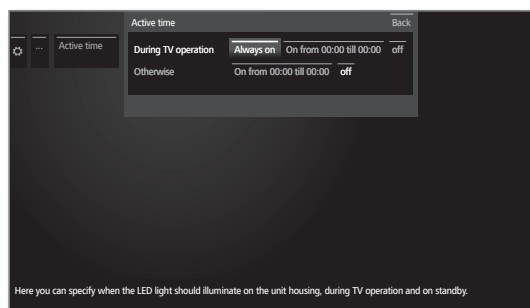

**During TV operation** Here you can specify when the LED shall light up during the TV mode.

**Otherwise** Here you can specify when the LED shall light up, if the TV set is switched off.



◀ ▶ ▲ ▼ Mark the desired setting or  
enter the desired time with the numerical keys.  
**OK** Accept settings.

**Always on** The LED backlighting is always switched on when the TV set is switched on.

**On from... till ...** The LED backlighting is always switched on during the selected time period.

**off** The LED backlighting is generally switched off.

## Determine the luminous intensity of the LED backlighting



▼ ▲ Mark **Luminous intensity**,  
▶ call settings for the luminous intensity.  
▼ ▲ Select desired level of luminous intensity.

## Further operation of the LED backlighting

In addition to the general default settings in the system settings, the LED backlighting can also temporarily be controlled via local and remote control. You will find further information on page 19.

**i** For playback of movies in 3D mode (see page 88) we recommend to disable the LED backlighting.

<sup>1</sup> Depending on the type of TV set.

## Rotate TV

Here you can set the range of rotation for the motorized stand and define the switch-off position of your TV set.

**i** Menu item **Rotate TV** appears only if you have an installation with motorized stand.

### Setting the range of rotation (rotation wizard)

By means of the rotation wizard you can define the rotation range of the TV set (maximum +/- 40 degrees) by setting the maximum right and left stop position.

HOME

**HOME:** Call **Home** view.



◀ ▶ ▲ ▼ Mark **System settings**,  
**OK** call System settings.

▼ ▲ Mark **Control**,  
▶ go to next column.

▼ ▲ Mark **more ...**,  
▶ call other settings.

▼ ▲ Mark **Rotate TV**,  
▶ go to next column.

◀ ▶ Select **Basic adjustments**,  
▶ call Basic adjustment.

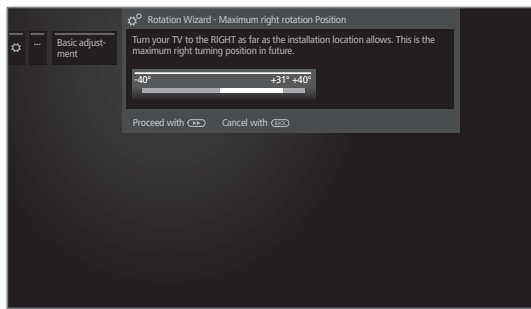

▶ **Basic adjustments (to the right)**  
Rotate your TV set to the right as far as the installation site allows.  
This will be the maximum right rotation position in future.



▶▶ proceed.

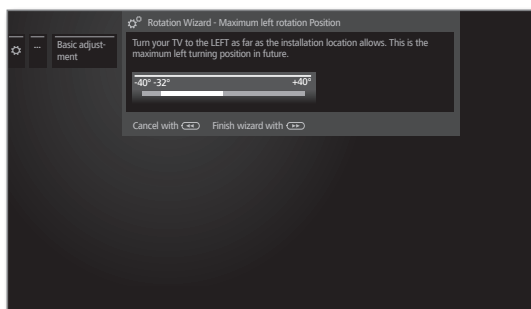

◀ **Basic adjustments (to the left)**  
Turn your TV set to the left as far as the installation site of your set allows.  
This will be the maximum left rotation position in future.



▶▶ End of wizard.

### Specifying the switch-off position

This is where you specify the position that the TV will take when it is switched off. In order for the TV set to return to the determined switch-off position when switching it off, this must be activated (see below).

HOME

**HOME:** Call **Home** view.



◀ ▶ ▲ ▼ Mark **System settings**,  
**OK** call System settings.

▼ ▲ Mark **Control**,  
▶ go to next column.

▼ ▲ Mark **more ...**,  
▶ call other settings.

▼ ▲ Mark **Rotate TV**,  
▶ go to next column.

◀ ▶ Select **Set switch-off position**,  
▶ call **Set switch-off position**.

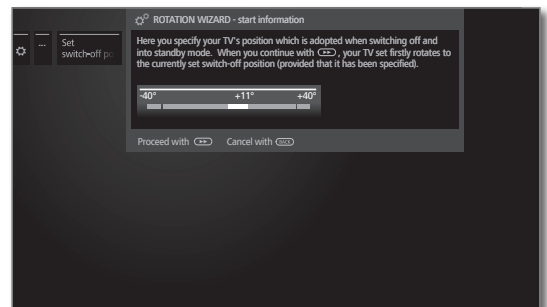

▶▶ Call dialogue for setting the new switch-off position.



◀ ▶ Set desired switch-off position.

**i** The switch off position can only be defined within the set rotation range (see left column).



▶▶ End of wizard.

### Activating the switch-off position

If the TV set is switched off with the on/off key on the remote control or at the control panel then it will turn to the defined switch-off position. When it is switched back on, it returns to the position last set.

HOME

**HOME:** Call **Home** view.



◀ ▶ ▲ ▼ Mark **System settings**,  
**OK** call System settings.

▼ ▲ Mark **Control**,  
▶ go to next column.

▼ ▲ Mark **more ...**,  
▶ call other settings.

▼ ▲ Mark **Rotate TV**,  
▶ go to next column.

▼ ▲ Select **Activate switch-off position**,  
▼ go to the next menu line below.

▼ ▲ Select **yes**,  
**OK** adopt.

**i** For rotating the TV set within the predefined rotation range see page 42.

## Record

You can set a pre-record and post-record time for timer recordings made without auto time control. This minimizes the risk that a part of the broadcast is not recorded due to the broadcast starting earlier and/or finishing later.

### Call Recording settings

HOME

**HOME:** Call **Home** view.



◀ ▶ ▲ ▼ Mark **System settings**,  
**OK** call System settings.

▼ ▲ Mark **Control**,  
▶ go to next column.

▼ ▲ Mark **more ...**,  
▶ call other settings.

▼ ▲ Mark **Recording**,  
▶ go to next column.

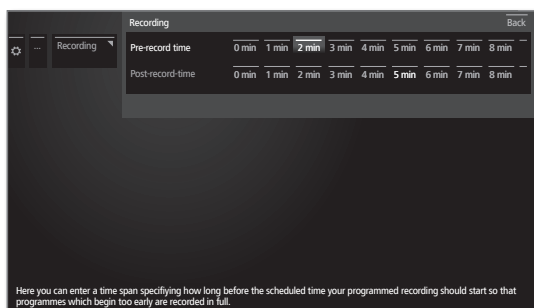

▼ ▲ Select **Pre-record time** or **post-record time**.

◀ ▶ Mark the desired duration of the pre-record time or of the post-record time,  
**OK** adopt time.

Factory setting: pre-record time: **1 min**,  
post-record time: **5 min**.

## Hard disks

### Checking the hard disk

You should launch a check of the integrated hard disk once a year or if problems arise when starting recordings (e.g. when transferring to time-shift playback).

### Call hard disk settings

HOME

**HOME:** Call **Home** view.



◀ ▶ ▲ ▼ Mark **System settings**.  
**OK** call System settings.

▼ ▲ Mark **Control**,  
▶ go to next column.

▼ ▲ Mark **more ...**,  
▶ call other settings.

▼ ▲ Mark **Hard disks**,  
▶ go to next column.

▼ ▲ Mark **Check integrated one**,  
▶ confirm.

A warning note will be displayed.



**OK** Press at least for three seconds to start the checking.

Or:

BACK

**BACK:** Cancel procedure.

**i** Checking the hard disk (check disk) may take up to 20 min. Never ever switch off the TV set during a check disk process.

After the check, a message will appear on the screen showing the results of the check and tips on how to resolve any problems that are present, should there be any.

**i** After checking of the hard disk the TV set must be switched off and on again.

### Formatting the hard disk

If problems were detected when the hard disk was being tested (see left column), re-formatting may be able to remedy the problem. Additionally, you can re-format the hard disk in order to quickly and easily delete all the data stored on it.

### Warning!

Formatting the hard disk will erase all data stored on it!

HOME

**HOME:** Call **Home** view.



◀ ▶ ▲ ▼ Mark **System settings**.  
**OK** call System settings.

▼ ▲ Mark **Control**,  
▶ go to next column.

▼ ▲ Mark **more ...**,  
▶ call other settings.

▼ ▲ Mark **Hard disks**,  
▶ go to next column.

▼ ▲ Mark **Format integrated one** or **Format external one**,  
▶ confirm.

A warning note will be displayed.



**OK** Press at least for three seconds to start formatting.

Or:

BACK

**BACK:** Cancel procedure

**i** Never ever switch off the TV set during a formatting process.

After the formatting, a message will appear on the screen showing the results of the formatting and tips on how to resolve any problems that exist, should there be any.

**i** After the formatting the TV set must be switched off and on again.

### Note on formatting external USB disks:

The TV set uses the hard disk file system FAT32. The file system NTFS is not supported. PCs with the operating system Microsoft Windows only support a total hard disc volume of 32GB when formatting on FAT32. Larger hard disks are automatically reduced in their capacity by this.

Format external USB disks that you wish to use with the TV set as described above.

## Network settings

Under Network settings you make settings to your network adaptors and the various types of media.

### Call network settings

HOME

**HOME:** Call **Home** view.



◀ ▶ ▲ ▼ Mark **System settings**,  
**OK** call System settings.

▼ ▲ Mark **Multimedia / Network**,  
 ▶ go to next column.

▼ ▲ Mark **Network settings**,  
 ▶ go to next column.

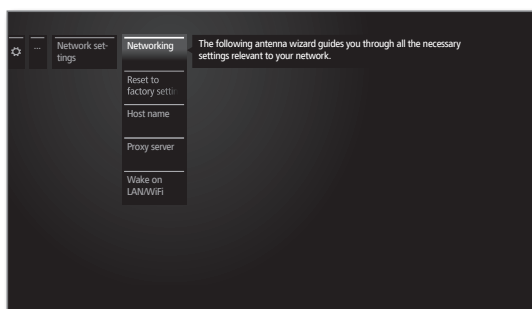

▼ ▲ Select desired menu item,  
 ▶ go to next column.

### Network

The Network wizard will be started. You see the current network status.



▶▶ Change network settings.

### Network selection

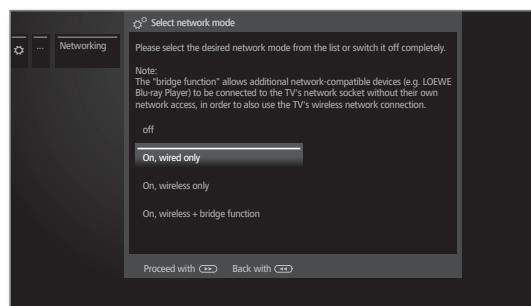

▼ ▲ Select network access.

### Explanations of the setting options:

Off deactivates all existing network adaptors of your TV set.

On, wired only Access to the network only via a network cable. The wireless access is deactivated. The network wizard will be opened (see page 115).

On, wireless only Access to the network only via WLAN. The access via a network cable is deactivated. The network wizard will be opened (see page 115).

On, wireless + bridge function Both network adaptors are activated. Wireless Internet access is possible (WLAN). Internet-enabled devices connected to the network socket (LAN) (e.g., Loewe MediaCenter, Loewe BluTechVision 3D) can use the wireless connection of the TV set to access the Internet via the WLAN bridge function. The network wizard will be opened (see page 115).

**Under no circumstances** may the TV set be **wired** and at the same time connected by a **wireless connection** to the same network, e.g. router. This may cause severe operational faults!



**OK** proceed.

### Explanations of the setting options in the network menu:

Networking Here, the network wizard starts that guides you through all necessary settings to your network (see right hand column).

Reset to factory settings Here, all network settings are reset to factory defaults.

Host name Give your TV set a name so that it can be uniquely identified in the network. For the procedure of text entry see page 17.

Proxy server Do the settings for using a proxy server. The proxy server wizard will be called (see page 116). For further information see below.

Wake on LAN/WiFi If you **allow** Switch on via LAN/WLAN, the TV set can be switched on via the network when it is in standby.

**i** Thus, energy consumption of the TV set will increase when it is in standby mode!

### Configuration of the built-in LAN adaptor

**i** The network wizard was called via the network access setting **On, wired only** (see page 114).

#### IP configuration



◀ ▶ Select type of **IP configuration**.

**automatic:** Automatic configuration of the IP address via DHCP server or via multiple protocols according to UPnP specification (including DHCP).



**OK** proceed to network status (see below).

**manual:** Enter your fixed static IP addresses manually (see below).



**OK** proceed to **Manual IP configuration**.

#### Manual IP configuration

If **manual** has been selected under **IP configuration**:

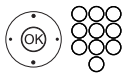

▲ ▼ Enter IP, Subnet mask, Gateway and DNS server addresses in succession with the numerical keys on the remote control.

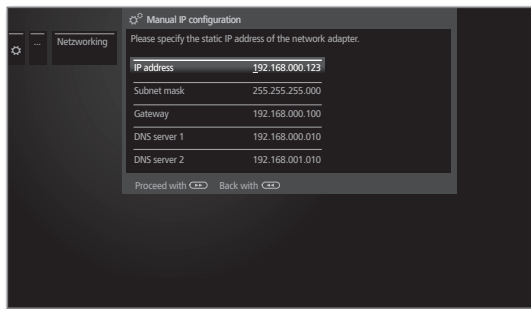

▶▶ proceed to **network status**.

#### Network status

You see the current network status again.



**BACK:** End of wizard.

### Configuration of the built-in WLAN bridge adaptor

**i** The network wizard was called via the network access setting **On, wireless only** or **Wireless + bridge function** (see page 114).

#### Search for Access points

The TV set now searches for wireless routers.



**BACK:** Stop search.

#### Access point selection

After the end of the search:



▲ ▼ Select required access point from the options found.

**OK** Proceed to entry of WLAN password.

#### No access point found

If the desired access point is not found:



◀ ▶ ▼ ▲ Mark **Search again**,  
**OK** repeat search for wireless routers.



Or:

◀ ▶ ▼ ▲ Mark **Enter access point manually**,  
**OK** enter manually the SSID of the desired access point, e.g., when the SSID of the access point is not transferred. For the procedure see page 17.

**OK** Proceed to entry of WLAN password.

#### WLAN password (WPA password / WEP password / WEP index)

If your wireless network is not encrypted: Proceed to **IP configuration**.

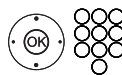

Enter WLAN password (for procedure see page 17).

**i** In case of an unknown WLAN key, contact your network administrator.

**i** For encryption types supported, see page 143.

For WEP encryption



◀ ▶ Select the **WEP index**,  
**OK** proceed to **IP configuration**.

#### IP configuration



◀ ▶ Select type of **IP configuration**.  
 For the further workflow of the network wizard see left column under IP configuration.

#### Network status

At the end of the network wizard you see your current network status again.



**BACK:** End of wizard.



### Explanation of the adaptor settings:

Network	shows the current type of connection ( <b>wireless</b> or <b>wired</b> ).
IP configuration	The current assignment method for the IP address of your TV set ( <b>automatic</b> or <b>manual</b> ).
IP address	Your current IP address.
Subnet mask	Your current subnet-mask IP address.
Gateway	The IP address of your gateway.
DNS server 1	Your current first DNS server IP address.
DNS server 2	Your current second DNS server IP address.
Network SSID	(for wireless connection only) The name of your network.
MAC address (TV)	(for wired connection only) Indicates the MAC address that is built into the hardware of your TV set's wired network adaptor (LAN).
MAC address (WLAN)	(for wireless connection only) Indicates the MAC address that is built into the hardware of your TV set's wireless network adaptor (WLAN).
Connection status	Gives you information about the current status of your wireless connection (save settings, connecting, login failed, access point not found, not connected, connection established).
Link quality	Specifies the signal strength as a percentage.

### Proxy server settings

In the proxy server wizard your TV set establishes the link with a home network with proxy server.

- i** A proxy server is not necessary for most home networks.
- i** Contact your home network administrator if you are unclear about the proxy server settings.

### Use proxy server

Specify if a Proxy server is used in your home network.



◀ ▶ Mark **Use** or **Don't use**.  
**OK** confirm selection.

- i** The following settings will only be requested after the selection of **Use**.

### Proxy server name

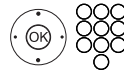

Specify the name or IP address of the proxy server used.  
For the procedure of text entry see page 17.

### Proxy port number

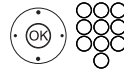

Specify the network port number of the proxy server.  
For the procedure of text entry see page 17.

### Proxy server login

Specify whether your proxy server requires a special login.



◀ ▶ Mark **No login** or **Login necessary**.  
**OK** Confirm selection.

### User name and password

- i** User name and password are only requested after the selection of **Login necessary**.

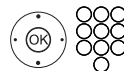

Enter your login data for the proxy server.  
For the procedure of text entry see page 17.





## Multimedia settings

Under this menu item you find further settings for Audio, Video and Photo.

### Calling the Multimedia settings menu

HOME

**HOME:** Call **Home** view.



◀ ▶ ▲ ▼ Mark **System settings**.

**OK** call System settings.

▼ ▲ Mark **Multimedia / Network**.

▶ go to next column.

▼ ▲ Mark **Multimedia settings**.

▶ go to next column.

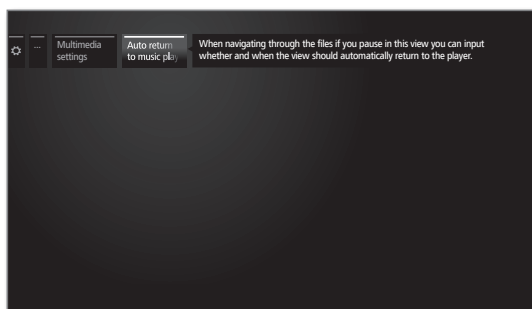

▼ ▲ Select desired settings.

### Explanations of the setting options in the Multimedia settings menu:

**Auto return to music player** The music player will reappear whenever another dialogue, e.g., music selection is called during playback (see page 67), and no keys are pressed for the set time period.  
You can specify if and after which time the music player reappears (selection options are **No**, **After 1 min**, **After 5 min**).



## Connections

Settings for the connection of external appliances are made in this menu.

**i** The menu item **Connections** is not available while a timer recording is active.

### Calling the connections menu

HOME

**HOME:** Call **Home** view.



◀ ▶ ▲ ▼ Mark **System settings**,  
**OK** call System settings.

▼ ▲ Mark **Connections**,  
▶ go to next column.



▼ ▲ Select desired settings.

### Explanations of setting possibilities in the Connections menu:

**Sound components** The sound components wizard helps you to configure the components that are used to reproduce the TV sound. You will find a description of the sound components wizard on page 119.

**Antenna DVB** Here you can set the parameters of the DVB-T and the DVB-S antenna with the antenna wizard. The setting options of the DVB antennas are described in the Initial installation routine (starting from page 21).

**AV connecting settings** In the AV connecting settings the parameters for the AV and AVS connection sockets can be adapted. You will find further information on page 123.

**Digital Link** All settings for Digital Link are made here (see page 124).

**Assign digital audio input** You can assign the digital audio input socket (**SPDIF IN**) to an AV input (AV, HDMI, AVS, etc.) here (see page 125).

**Gaming mode** Here you can set a faster display of your activities on the screen for various inputs of the TV set, e.g., for games consoles (see page 124).

## Sound components

The sound components wizard helps you to configure the components that are used to reproduce the TV sound. For sound reproduction, you can configure the TV loudspeakers, active loudspeakers, loudspeaker systems as well as analogue and digital HiFi/AV amplifiers.

Your TV set is equipped with an integrated digital multi-channel audio decoder. Sound signals with up to six channels (5.1 surround sound) can be emitted through the **DIGITAL AUDIO LINK** interface, irrespective of whether the sound signal comes from an external device (DVD player, Blu-ray player) or from a DVB station.

For settings for loudspeaker systems and active speakers at the **DIGITAL AUDIO LINK** interface of the TV set, see page 120.

For sound formats supported by the digital audio decoder, see page 141.

### Calling the sound components wizard

For information on navigation within the wizard refer to **General information on menu operation** on page 16.

HOME

**HOME:** Call **Home** view.



◀ ▶ ▲ ▼ Mark **System settings**.

**OK** call System settings.

▲ ▼ Select **Connections**.

▶ go to next column.

▲ ▼ Select **Sound components**.

▶ go to next column.

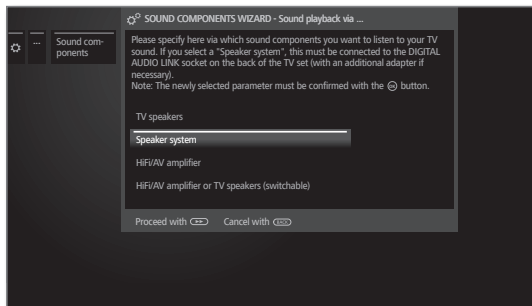

▲ ▼ Select **Sound component**.

For selectable items see right hand column.

Conclude this step (for navigation refer to page 16).

### Sound playback via ...

Some sound components can only be selected when the respective device is connected to the TV set.

TV speakers Sound reproduction via the built-in TV speakers (factory setting).

With the selection of TV speakers the wizard will end.

Speaker system Sound reproduction via a loudspeaker system or active loudspeakers (see page 120).

How to connect a speaker system is described on page 130. The connection of active speakers is described on page 131.

HiFi/AV amplifier Sound reproduction via an external analogue or digital audio amplifier (see page 122).

How to connect an HiFi/AV amplifier is described on page 131.

HiFi/AV amplifier or TV speakers (switchable) Sound reproduction optionally via an external analogue or digital audio amplifier (see page 131) or via the built-in TV loudspeakers.

The selection options for switching between sound components can be called via the function list under **Sound mode** (see page 37). See page 90 for further information.



## Adjusting the speaker system

### Sound playback via ... – Speaker system

Enter here that you want to hear the TV sound over a speaker system. If you connect active speakers, please use the setting **Speaker system**.

- i** For information on navigation within the wizard refer to **General information on menu operation** on page 16.
- i** How to connect a speaker system to the TV set is described on page 130.
- i** When setting up the speaker system for the first time, the configuration starts with the step **Connect front speakers** (see below).
- i** Speaker system was selected in the Sound components wizard (see page 119).

Configuration/  
modification

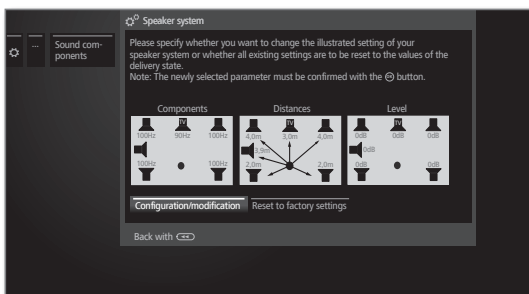

If you want to set up or change a speaker system:

- ◀ ▶ Select **Configuration/modification**.  
If nothing has been set yet, the factory settings or otherwise the last set values are displayed.

Conclude this step (for navigation refer to page 16).

Configuration/  
modification

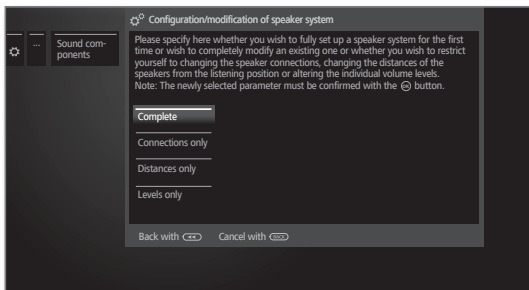

- ▼ ▲ Select **Complete**.

Conclude this step (for navigation see page 16) and continue to connect and set the **front speakers**.

Connect  
front  
speakers

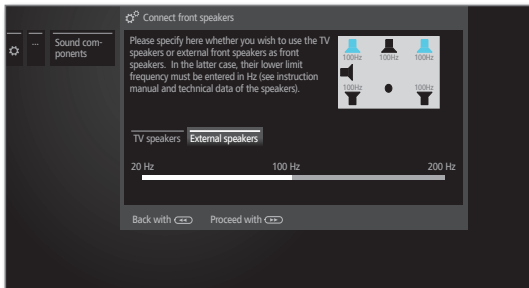

- ◀ ▶ Select **External speakers** or **TV speakers**.



- ▼ For **External speaker** go to the frequency bar below and
- ◀ ▶ set the **lower limit frequency** of the external front speakers in steps of 10 Hz.

- i** Select the start value of the frequency response of the speakers for the correct setting (e.g., 50Hz for the specification "Frequency response 50-20,000Hz"). See the technical data of the speakers for the value.

- i** You can replace the external front speakers by the TV speakers if necessary. In this case, **TV speakers**. Then, the TV speakers transmit the sound of the front speakers.

Conclude this step (for navigation see page 16) **surround speakers**

Connect  
surround  
speakers

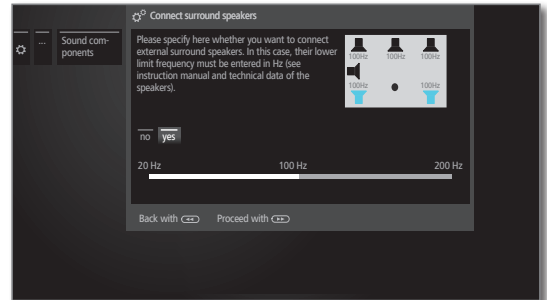

- ◀ ▶ Select **yes** or **no** for the external surround speakers.

In case, external speakers were chosen as surround speakers:

- ▼ Select frequency bar
- ◀ ▶ set the **lower limit frequency** of the surround speakers in 10 Hz steps.

- i** Select the start value of the frequency response of the speakers for the correct setting.

Conclude this step (for navigation see page 16) **centre speaker**

Connect  
centre  
speaker

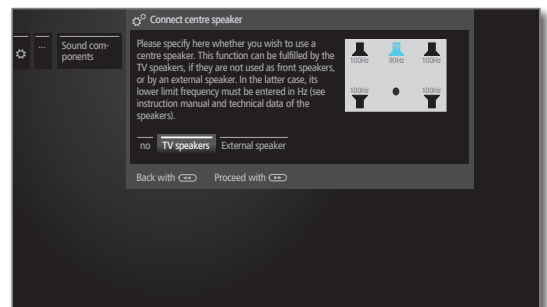

- ◀ ▶ Select whether the **TV speakers** or an **External speaker** is to reproduce the centre sound or **no** if no centre speaker is connected.

- i** If no centre speaker is connected, the front speakers also transmit the centre sound parts additionally.

- ▼ For **External speaker** go to the frequency bar below and

- ◀ ▶ set the **Lower Limit Frequency** of the external front speakers in steps of 10 Hz.



- i** Select the start value of the frequency response of the speakers for the correct setting.

Conclude this step (for navigation see page 16) and continue to connect the **Subwoofer**.

## Connect subwoofer

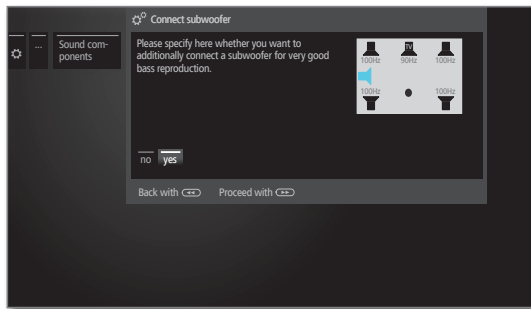

◀ ▶ Select **yes** or no for Subwoofer.

**i** If no subwoofer is connected, the front speakers additionally transmit the sound parts intended for the subwoofer as far as possible.

Conclude this step (for navigation see page 16) and proceed to **Distance to left hand front speaker**.

## Distance to left front speaker

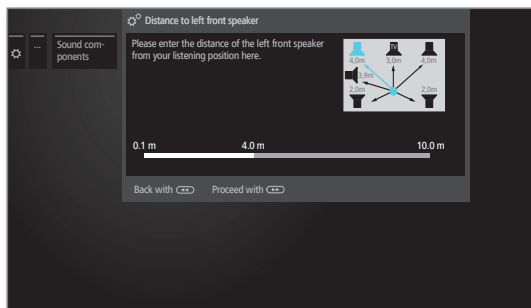

◀ ▶ Set the distance between the left front speaker and your listening position in 10 cm steps.

**i** Measure the distances from your listening position to the front, surround, and centre speakers respectively. The digital audio decoder calculates delay times from this for the loudspeaker signals, so that these reach the listener simultaneously.



▶▶ proceed to the respective other speakers (right front speaker, left surround speaker, right surround speaker, centre speaker and subwoofer) and also



◀ ▶ The selected speaker will be coloured blue.

After setting the distance to the subwoofer.



▶▶ proceed to **Adjust speaker level**.

## Adjust speaker level

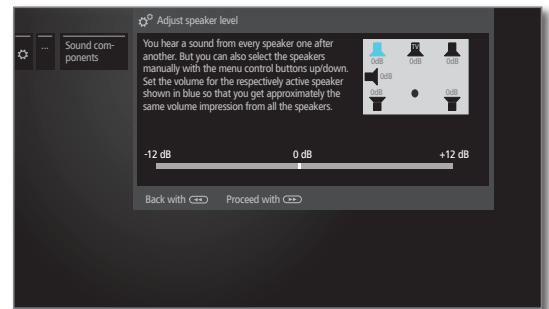

◀ ▶ Adjust the volume for the speaker.

▶▶ Proceed to next speaker or

▲ ▼ select speakers manually.

**i** For balanced audio reproduction all speakers should be set to the same volume level. A noise signal will be reproduced automatically on each speaker in succession. Adjust every speaker to equal perceived volume from your listening position. The selected speaker will be coloured blue.

After adjustment of the last speaker.



▶▶ Proceed to **Subwoofer phase**.

## Subwoofer phase



◀ ▶ Test both values (**0°** and **180°**) and select the one with which you get a clearer bass reproduction from your listening position.

Conclude this step (for navigation refer to page 16).

This ends the sound components wizard for connecting and setting up a speakers system.



## Setting the HiFi/AV amplifier

### Sound playback via ... - HiFi/AV amplifier

The sound components wizard permits configuration of different audio amplifiers (stereo amplifiers, surround amplifiers, analogue or digital) with different digital audio formats (Dolby Digital, dts, MPEG, and stereo/PCM). See the user guide of the audio amplifier for more information.

**i** For information on navigation within the wizard refer to **General information on menu operation** on page 16.

**i** How to connect an HiFi/AV amplifier you find starting from page 131.

HOME

**HOME:** Call **Home** view.



◀ ▶ ▲ ▼ Mark **System settings**, **OK** call System settings.

▲ ▼ Select **Connections**,  
▶ go to next column.

▲ ▼ Select **Sound components**,  
▶ Call sound components wizard.

Sound reproduction via ...

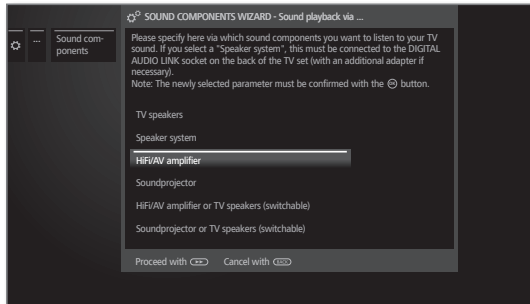

▲ ▼ Mark **HiFi/AV amplifier** or **HiFi/AV amplifier or TV speakers (switchable)**.

**HiFi/AV amplifier** Select setting when an amplifier is connected and the TV speakers are not used.

**HiFi/AV amplifier or TV speakers (switchable)** Select setting when an amplifier is connected and the TV speakers are used. In the sound mode selection the audio reproduction can then be switched between the amplifier and the TV speakers.

Conclude this step (for navigation refer to page 16).

Type of sound transmission

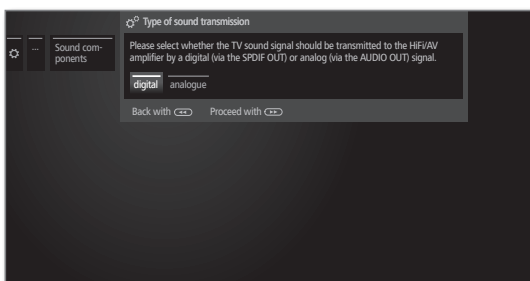

◀ ▶ Select whether the sound is to be transmitted digitally or analogue to the the amplifier (see right hand column):

**digital:** Proceed to **Sound formats**.  
**analogue:** proceed to **Type of amplifier**.

Sound formats

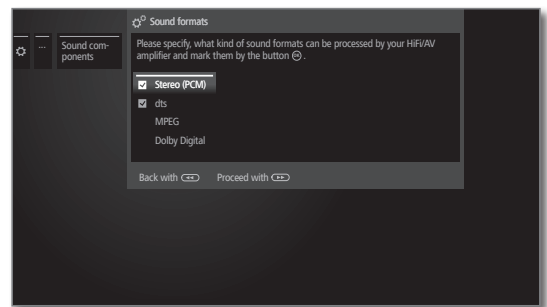

▼ ▲ Select sound formats which can be decoded with the digital amplifier (see operating manual of the used amplifier).

**OK** adopt sound formats.

Conclude this step (for navigation refer to page 16).

Amplifier Type

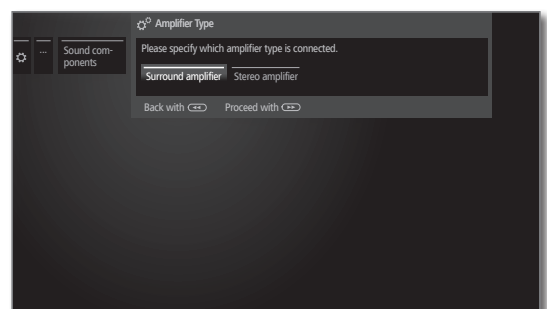

◀ ▶ Please select the amplifier type which is connected (surround or stereo amplifier).

Conclude this step (for navigation refer to page 16).

TV loudspeakers as centre speaker

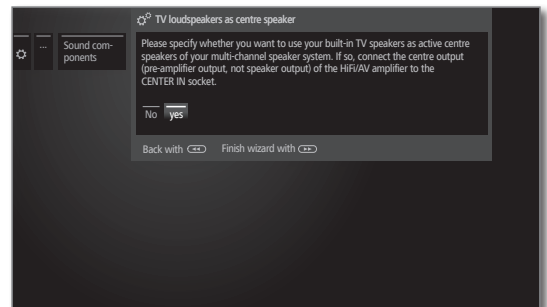

If surround was selected for type of amplifier:

For every connected surround amplifier, select whether the TV loudspeakers are to be used as centre speakers.

If **yes**, establish a connection between the centre output of the amplifier and the **CENTER IN** socket of the TV set via a cinch cable.

**Attention: Do not use the centre speaker connection of the amplifier, use the centre pre-amp output instead!**



▶▶ End of wizard.

## Antenna DVB

Here you can make settings for the DVB-T antenna and call the antenna wizard for the DVB-S antenna.

### Call Antenna DVB

HOME

**HOME:** Call **Home** view.



◀ ▶ ▲ ▼ Mark **System settings**.  
**OK** call System settings.

▼ ▲ Mark **Connections**,  
▶ go to next column.

▼ ▲ Mark **Antenna DVB**,  
▶ go to next column.



▼ ▲ Select the desired setting,  
▶ call.

### Explanations of the setting options in the antenna DVB menu:

**Antenna DVB-S** Here the antenna wizard starts guiding you through all the settings relevant to the DVB-S antenna. The settings of the DVB-S antenna wizard are explained in the procedure of initial installation (starting from page 24).

**Antenna DVB-T** Here you can set whether your DVB-T antenna needs a supply voltage.  
Antennas with an integrated amplifier need a supply voltage on the antenna line. In this case, select **Supply voltage 5V** and confirm with **OK**.  
Otherwise, select **No supply voltage** and confirm also with **OK**.

### Positioning/aligning DVB-T antenna

If you are receiving one or more DVB-T stations with picture and sound interference then you should change the installation location and alignment of the antenna. Ask your dealer to tell you which channels are used to broadcast the DVB-T stations in your region.

A DVB-T station is received and selected.  
Calling manual search (see page 93).

Due to the preset stations, the signal source is already selected as DVB-T. Position and align the antenna so that maximum **C/N** values and **levels** are reached (see status bar on page 93).

Search for DVB-T stations one after the other and compare values for **C/N** and **Level**. Then position/align the antenna to the weakest station so that maximum values for **C/N** and **Level** are obtained. The value for **BER** should be as low as possible.

Thereafter, perform an automatic search for all DVB-T stations (see page 94).

## AV connection settings

In the AV connection settings menu the parameters for the AV and AVS connection sockets can be adapted.

### Calling the connections menu

HOME

**HOME:** Call **Home** view.



◀ ▶ ▲ ▼ Mark **System settings**.  
**OK** call System settings.

▼ ▲ Mark **Connections**,  
▶ go to next column.

▼ ▲ Mark **AV connecting settings**,  
▶ go to next column.

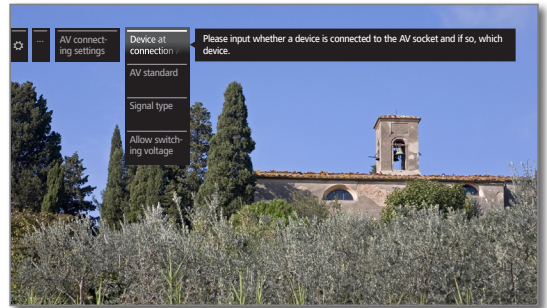

▼ ▲ Select the desired setting,  
▶ call.

### Explanations of setting possibilities in the AV connecting settings menu:

**Device at connection AV** Indicate here whether a set and, if yes, which one is connected to the AV socket. See connection of the devices starting from page 127.

**AV standard** You set the AV standard of the connected appliance to AV or AVS here.  
Normally you leave the setting to **Automatic**. If the standard of the connected appliance is not detected automatically, select the right standard.  
Ask your dealer or consult the operating manual of the connected appliance if necessary.

**Signal type** You set the signal type of the device connected to AV or AVS here. Normally, you should leave the setting to **Automatic SVHS/VHS**, otherwise select a suitable signal type. You can find out more from your dealer.

**Allow switching voltage** If this function is activated, the video and audio of an external unit connected to the **AV** connector (not to AVS) will immediately be reproduced on all TV broadcast sites when playback is started up, provided that the external unit supplies a switching voltage.





## Digital Link

In the digital link menu you make further setting for comfortably linking external devices to the TV set.

### Call Digital Recorder Link menu

HOME

**HOME:** Call Home view.



◀ ▶ ▲ ▼ Mark **System settings**,  
**OK** call System settings.

▼ ▲ Mark **Connections**,  
 ▶ go to next column.

▼ ▲ Mark **Digital Link**,  
**OK** call Digital Link.



▼ ▲ Select the desired setting,  
 ▶ call.

### Explanations of the setting options in the Digital Link menu:

**Digital Link HD functionality** Herewith you can allow or forbid the automatic communication between the TV set and linked external devices (e.g., BluRay player). Among other things, it's role is that these devices switch mutually on and off.

**Remote TV switch on via Digital Link** Here you can select whether the TV set is to switch on automatically from Standby mode, if **Digital Link HD** or **Digital Link Plus** capable devices connected to an HDMI or to AV inputs start playback or display a screen menu.

## Gaming mode

For the inputs of your TV set on which game consoles, PC applications or even Karaoke machines are operated, we recommend you to activate the **Gaming mode**. Your activities are then displayed quicker on the screen by reducing the complex picture improving techniques. This mode can be set separately for every input of your TV set.

### Call Gaming mode menu

HOME

**HOME:** Call Home view.



◀ ▶ ▲ ▼ Mark **System settings**,  
**OK** call System settings.

▼ ▲ Mark **Connections**,  
 ▶ go to next column.

▼ ▲ Select **Gaming mode**,  
**OK** call.

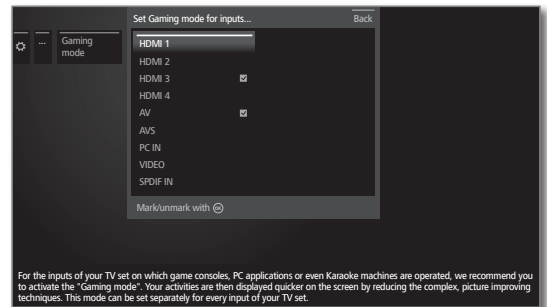

For the inputs of your TV set on which game consoles, PC applications or even Karaoke machines are operated, we recommend you to activate the "Gaming mode". Your activities are then displayed quicker on the screen by reducing the complex, picture improving techniques. This mode can be set separately for every input of your TV set.



▲ ▼ Select connection,  
**OK** Gaming mode for selected connection on/off.

You can recognise AV connections with set Gaming mode by the symbol  after the connection name. A dice icon is shown in the extended station list behind the corresponding AV input when filtering on the AV list.

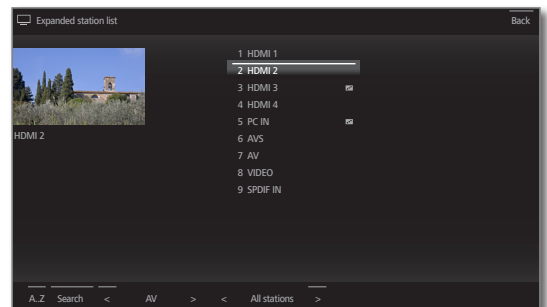

## Assign digital audio input

In order to be able to hear also the digital sound of an external device connected to an AV input, an AV input can be assigned to the digital audio input socket **SPDIF IN** of your TV set. By switching to this AV input, the digital audio signal at the **SPDIF IN** input is communicated to the integrated digital multi-channel audio decoder and the digital audio output socket **SPDIF OUT**. You will then hear the digital sound of the assigned AV input instead of the analogue sound if available.

### Connecting devices to the digital audio input

For the digital audio playback from an external device, e.g. the DVD player, you have to feed the digital audio signal to the TV set. The external digital audio signal can be reproduced via the digital multi-channel audio decoder integrated in the TV set or via an externally connected digital audio amplifier.

- i** If an external audio amplifier is used, this must be registered in the sound components wizard (see page 119).

HOME

**HOME:** Call **Home** view.



◀ ▶ ▲ ▼ Mark **System settings**.  
OK call System settings.

- ▼ ▲ Mark **Connections**.
  - ▶ go to next column.
- ▼ ▲ Select **Assign digital audio input**,
  - ▶ go to next column.
- ▼ ▲ Select AV input.

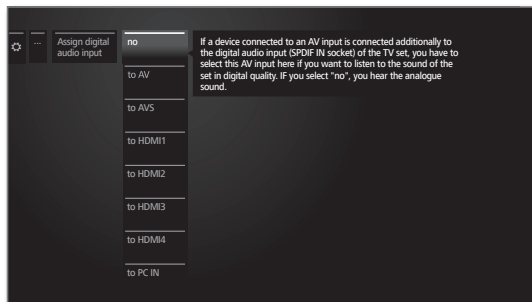

OK adopt.

To connect a DVD player to the digital audio input of the TV set, for example, connect the digital output socket of the DVD player (DIGITAL OUT) via a cinch cable to the **SPDIF IN** socket on the TV set (see right hand column).

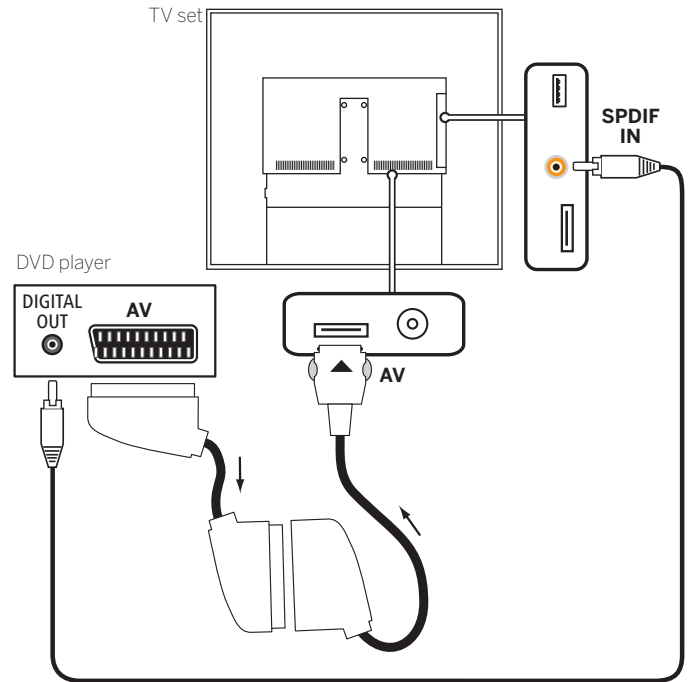

Connection example for a DVD player



## Devices to the HDMI connections

The HDMI connections (High Definition Multimedia Interface) allow the transmission of digital video and audio signals from a player (e.g. DVD player, Blu-ray player, game console, camcorder, set-top box) via a single cable.

The digital video and audio data are transmitted without data compression digitally and therefore lose none of their quality.

A maximum of five devices can be connected in cascade to every HDMI socket. The devices are arranged in the AV menu and in the station list below the appropriate HDMI socket. If the respective device sends its own device name, this appears in place of the connection name.

Your TV set can show optimally 24p movies, which are output from a connected HDMI player, e.g., Loewe BluTech Vision 3D, (see glossary, page 149).

Digital video signals from a DVI player can be also be reproduced by the HDMI connection using a DVI/HDMI adaptor cable. The sound must be piped in additionally.

HDMI and DVI both use the same copy protection method HDCP.

### Connecting the device

Switch off all devices before connecting them.

Connect the device by an HDMI cable (Type A, 19-pole) to one of the **HDMI** sockets of the TV set.

An HDMI device is connected to the side HDMI socket (e.g. camcorder) in the same way as shown in the figure.

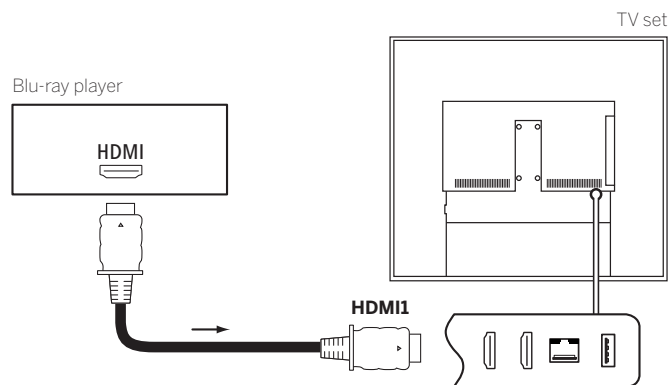

Connection example of an HDMI device (e.g. Blu-ray Player)

### Connecting an external device via HDMI/DVI adaptor

If your external device, e.g., a PC has an HDMI interface, you can also connect the this via an HDMI socket to your TV set. If a DVI/HDMI adaptor cable is used, the corresponding sound will either be fed through the analogue sound input socket of the VGA adaptor (1 on **AVS** (see page 129) or digitally via the **SPDIF IN** socket (see page 125) on the TV set.

**i** For digital sound transmission, the **SPDIF IN** socket must first be assigned to the desired HDMI input via **System settings → Connections → Assign digital audio input** (see page 125).

### Connecting an external device via HDMI

If your external device has an HDMI interface, the sound signal will usually be transmitted via the HDMI connection.

If this is not the case, connect the analogue or digital sound as described above. Refer to the appropriate operating manual for further information on the version of the HDMI interface on your external device, e.g., PC.

### Playback from the device

If the device at **HDMI** supports the **Digital Link HD** functionality, the TV set will automatically switch to the corresponding HDMI input after starting the replay at the HDMI device.

The HDMI input can also be called up manually:



Call **AV selection**.

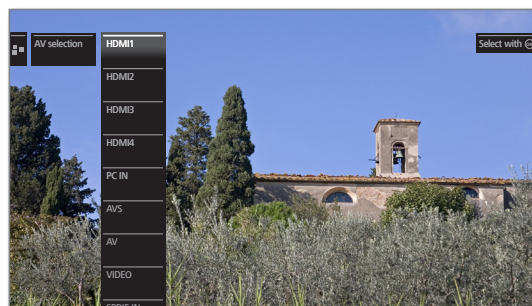

▲ ▼ Select **HDMI** socket.

With **Digital Link HD**-capable devices the device name may possibly appear in place of the connection name.

**OK** switch over.

Start playback on the connected HDMI device. The best possible format for the picture is detected and set automatically.

### Remote TV switch on via Digital Link

You can select whether the TV set is to switch on automatically from Standby mode if a disc is played or a screen menu displayed on a **Digital Link HD-enabled** device connected to **HDMI1** or **HDMI2**.

You can find the settings in the **System settings → Connections → Digital Link → Remote TV switch on via Digital Link** (see also page 124).

<sup>1</sup> Adaptor set is available as an accessory (see page 145).

## Devices on AV

An additional device such as a DVD player, VCR/DVD recorder etc. can be connected to the TV set by means of an adaptor at the **AV** socket (see pages 11). The required Scart adaptor is part of the adaptor set. The adaptor set is available as an accessory from your Loewe dealer (see page 145).

The AV sockets can process different signal types. Which signal type your accessory device provides can be found in the operating manual of the appropriate device.

Owing to the large number of AV devices available on the market, we can only mention a few examples for the connection of accessory equipment to the AV sockets here.

If the sound of the device connected to an AV socket is to be transmitted digitally, a cinch cable must be plugged between the coaxial digital output of the auxiliary equipment and the **SPDIF IN** socket of the TV set. In addition, the digital audio input must be assigned to the appropriate AV socket. This is done via **System settings → Connections → Assign digital audio input** (see page 118).

### Remote TV switch on via Digital Link

You can select whether the TV set is to switch on automatically from Standby mode if a disc is played or a screen menu displayed on a **Digital Link Plus-enabled** device connected to **AV**.

You can find the settings in the **System settings → Connections → Digital Link → Remote TV switch on via Digital Link** (see also page 124).

### Connecting a DVD player to the TV set

■ A **DVD player** has been selected in the **System settings → AV connecting settings → Device at connection AV** (see also page 127).

Switch off all devices before connecting them.

Connect the Scart output of the DVD player to the TV set's **AV** socket using the Scart adaptor<sup>1</sup>.

Plug the adaptor plug into the **AV** socket of the TV set so that the arrow on the plug is visible.

Use a fully equipped Scart cable (available from your dealer) for this.

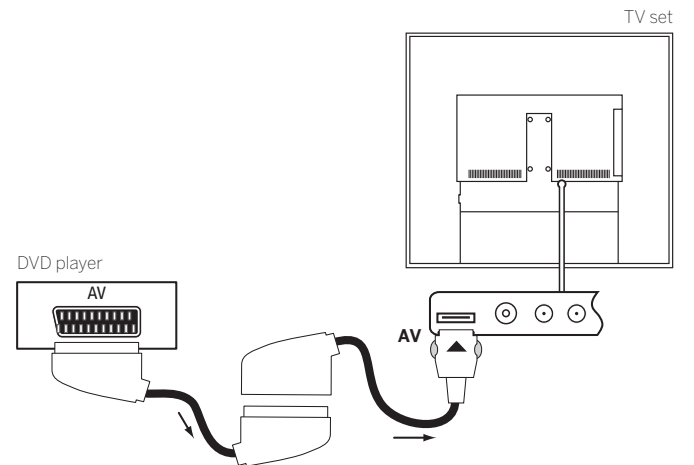

Connection example of a DVD player

### Playback from AV device

If the device at AV supports the Digital Link Plus functionality or if in the **System settings → Connections → AV connecting settings → Allow switching voltage → yes**, the TV set will automatically switch to the corresponding AV input after starting the replay at the AV device. The AV input can also be called manually, however.



Call **AV selection**.

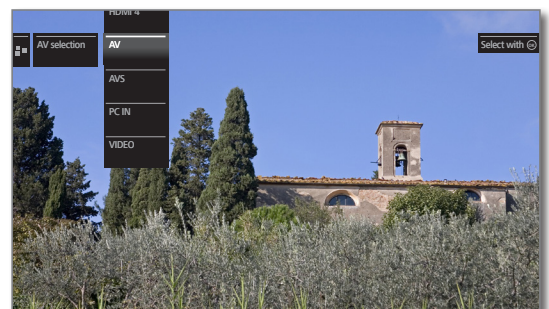

▲ ▼ Select **AV**,  
**OK** switch over.

Start playback on the connected device.

<sup>1</sup> Adaptor set is available as an accessory (see page 145).

## Connecting a DVD recorder to the TV set

■ A DVD recorder has been selected in the **System settings** → **Connections** → **AV connecting settings** → **Device at connection AV** (see also page 127).

Switch off all devices before connecting them.

Connect the Scart output of the DVD player to the TV set's **AV** socket using the Scart adaptor<sup>1</sup>. Use a fully equipped Scart cable (available from your dealer) for this.

Plug the adaptor plug into the **AV** socket of the TV set so that the arrow on the plug is visible.

If you want to receive and record analogue stations with the receiver (tuner) built into the recorder, the recorder must be looped into the aerial cable.

Connect the DVD recorder as shown in the connection example below.

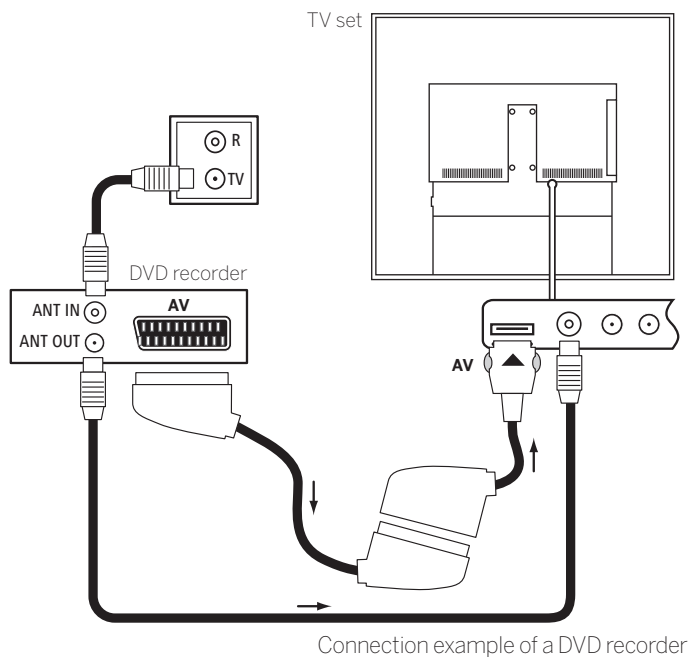

Connection example of a DVD recorder

## Playback from AV device



Call **AV selection**.

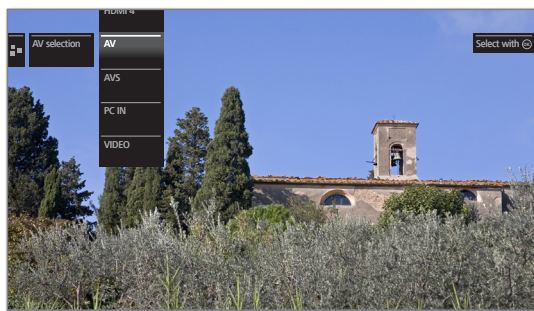

▲ ▼ Select **AV**,  
**OK** switch over.

Start playback on the connected device.

## Devices on AV

The AV input **AVS** (see page 11) offers the possibility of connecting, e.g., a digital camera, a camcorder or a PC via different adaptors. The adaptors required in the following are part of an adaptor set. The adaptor set is available as an accessory from your Loewe dealer (see page 158).

■ The AV inputs **AVS** and **PC IN** available in the AV selection both refer to the **AVS** socket at the side of the TV set. **AVS** is always to be chosen in the AV selection if the Scart adaptor or the S-video adaptor are used. Select **PC IN** in the AV selection when you connect a device via the VGA adaptor.

## Connecting Camcorder/camera

Switch off all devices before connecting them.

Connect the video output of the camcorder to the TV set's **AVS** socket using the S-video adaptor<sup>1</sup>. Use the AV cable enclosed with the camcorder for this.

Depending on the type of plug, an additional cable is required for the audio connection.

Plug the adaptor plug into the **AVS** socket of the TV set so that the arrow on the plug is visible.

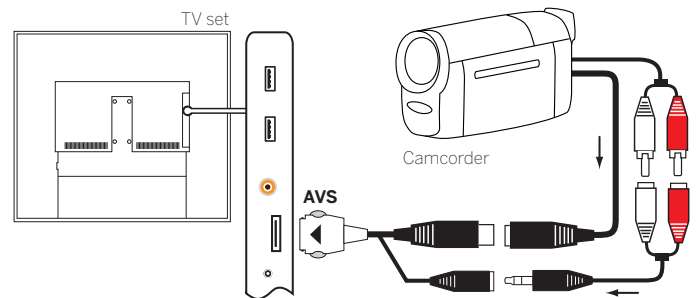

Connection example of a camcorder

If your camcorder has an HDMI output, you can also connect the device to the HDMI sockets **HDMI3** or **HDMI4** on the side of the TV set (see **Connections** page 11 or **Devices to the HDMI connections** page 126).

## Playback from AV device



Call **AV selection**.

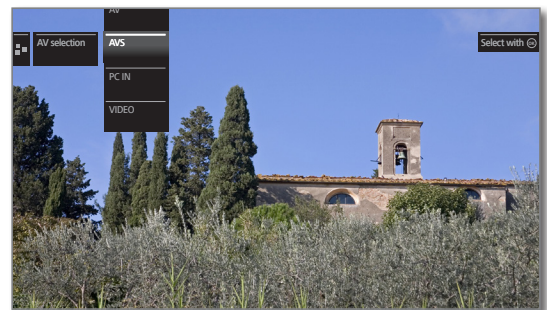

▲ ▼ Select **AVS**,  
**OK** switch over.

Start playback on the connected device.

<sup>1</sup> Adaptor set is available as an accessory (see page 145).

## Connecting PC / Set-top box

You can connect a PC and thus use the TV screen as a monitor.

**i** When connecting a PC or auxiliary device to the **AVS** socket of the TV set, adjust the output signal on your PC first so that it matches one of the signals in the table on page 144.

Switch off all devices before connecting them.

Connect the device to the TV set's **AVS** socket with a VGA cable and the VGA adaptor<sup>1</sup>. Plug the adaptor plug into the **AVS** socket of the TV set so that the arrow on the plug is visible.

Connect the analogue audio signal of the PC to the VGA adaptor via the jack plug socket.

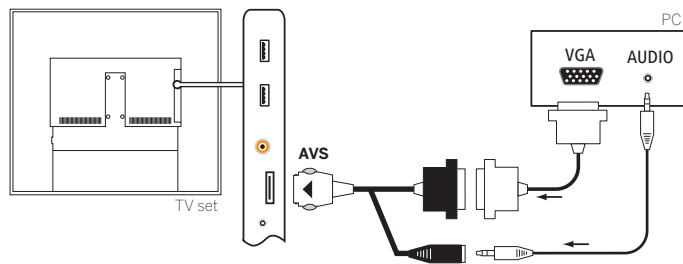

Connection example of a PC

**i** The adaptor set AV SL2xx includes an adhesive cable holder. Stick it below the cover of the side connectors. Secure the VGA cable with it to prevent the VGA adaptor from being pulled out of the jack by the heavy VGA cable.

For more information, refer to the installation instructions supplied with the adaptor kit.

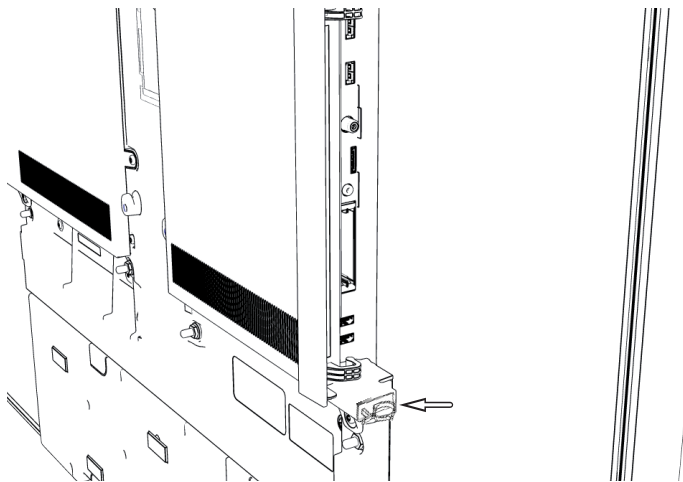

Alternatively, connect the digital audio output of the PC or auxiliary equipment to the **SPDIF IN** socket of the TV set with a cinch cable.

**i** The digital audio input can be assigned to the **AVS** or **PC IN** socket in **System settings** → **Connections** → **Assign digital audio input** (see page 118).

## Playback from the device



Call **AV selection**.

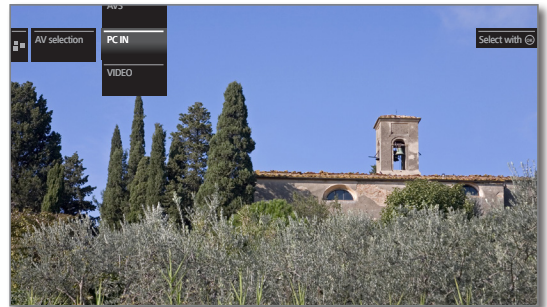

▲ ▼ Select **PC IN**.  
**OK** switch over.

## Adjusting the geometry of the PC picture

You can set the position (vertical, horizontal) and the phase position of your PC. The settings you find under **System settings** → **Picture** → **more ...** → **PC IN - Display** (see page 86).

## Connecting devices with component connection (YPbPr / YUV)

External units with component connection **YPbPr** (often informally referred to as YUV; see also Glossary on page 152) can be connected to the **AVS** socket of the TV set using two adaptors. In addition to the VGA adaptor, a component VGA adaptor is required (available from your dealer).

The other units are connected as described in the left column.

<sup>1</sup> Adaptor set is available as an accessory (see page 145).



## Connecting the Loewe speaker system

### Set-up

The arrangement of speakers and TV set can look like the illustration below:

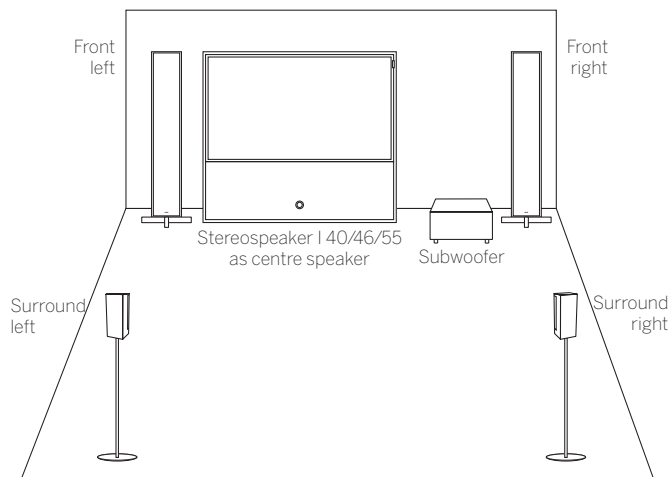

Example for placing the Loewe sound system

The front and surround speakers should be installed symmetrically to the TV set and to your sitting position.

You can position the subwoofer anywhere on the floor. We recommend placing it in front asymmetrically next to the TV set.

If you use another speaker than the Stereospeaker I 40/46/55 to be the centre speaker, place it in the middle below the TV set.

For the manual settings in the sound components wizard enter the distances of the centre speaker, and the front and surround speakers to your sitting position. This guarantees a natural spatial image of the sound.

### Connection

Switch off all devices before connecting them.

The subwoofer is connected to the TV set via the **DIGITAL AUDIO LINK** interface. Plug a network cable (Category 5e or higher) to the **DIGITAL AUDIO LINK** port of the TV set. Connect the Ethernet cable to the RJ45 socket of the **Digital Audiolink / Audiolink** converter available as accessory. Connect the converter to the **AUDIO LINK** socket of the Subwoofer.

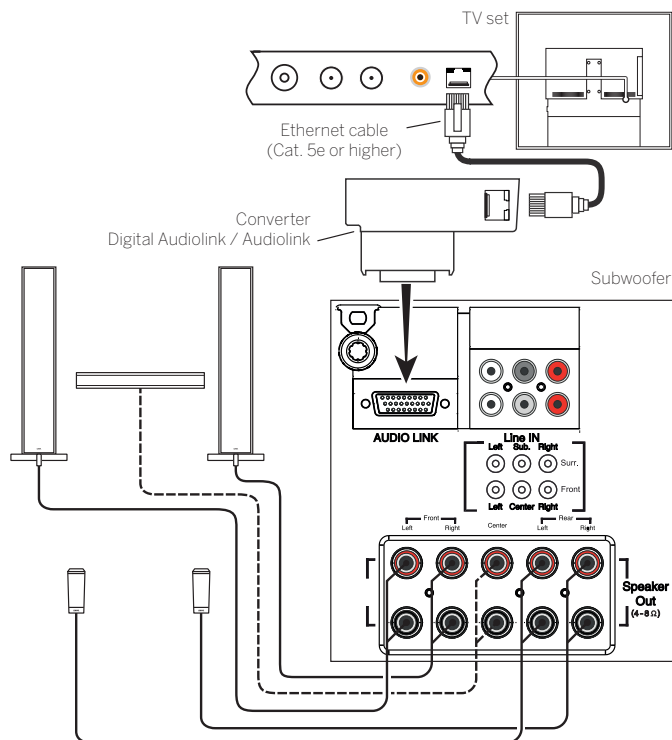

Connection of the Loewe speaker system to the TV set

### Connecting the speakers to the subwoofer

further information on the wiring of the speakers you find the the instruction manual of the speaker system.

### Sound reproduction via the speaker system

The sound reproduction by the speaker system can be adjusted in the sound components wizard.

Further information on settings for the speaker system you find starting from page 120.



## Connecting active loudspeakers

If you want to use another similar speaker system or active speakers, you can connect these to the **AUDIO LINK** port of the TV set using an adaptor cable.

Plug a network cable (Category 5e or higher) to the **AUDIO LINK** port of the TV set. Connect the Ethernet cable to the RJ45 socket of the **Digital Audiolink / Audiolink** converter available as accessory. To the other end of the convertor you connect the adaptor cable **Audiolink / 30cm / 9pin + 5.1 Out + Center In**. Connect the cinch connectors of the adaptor cable to the cinch connectors of the speakers / subwoofer.

The cinch connections of the adaptor cable are labelled:

<b>R</b> for Front right	<b>SR</b> for Surround right
<b>L</b> for Front left	<b>SL</b> for Surround left
<b>C</b> for Centre	<b>SUB</b> for Subwoofer

**■ The connections for the adaptor cable are pre-amplifier outputs. Therefore, only active loudspeakers / active subwoofers may be connected directly to the adaptor cable.**

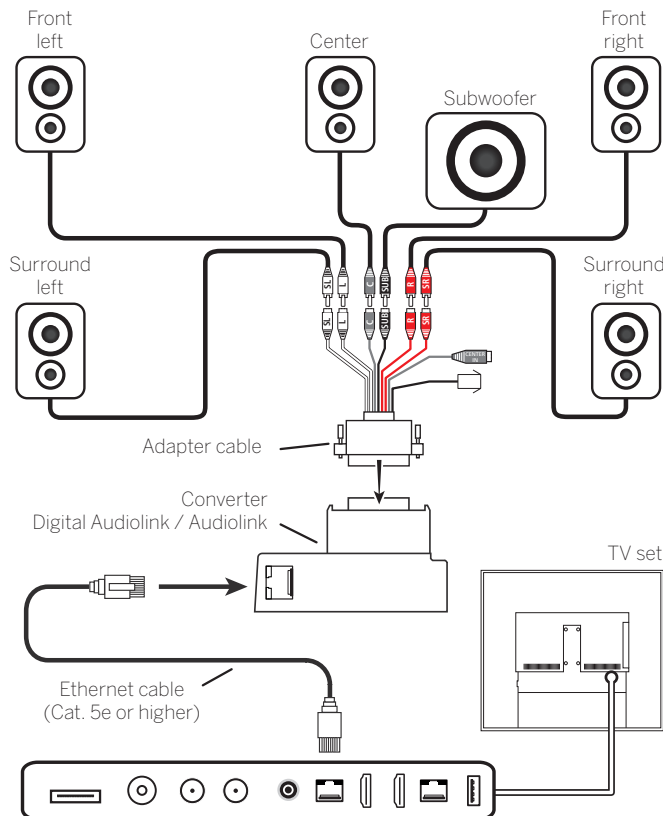

Connection of active speakers to the TV set

### Sound reproduction via the speaker system

The settings for sound reproduction via active speakers you find in the sound components wizard.

Further information on settings for the active speakers you find starting from page 120.

## Connecting the HiFi/AV amplifier

### Connecting digital HiFi/AV amplifiers

Connect the digital audio output of the TV set **SPDIF OUT** to the digital audio input of the amplifier via a cinch cable:

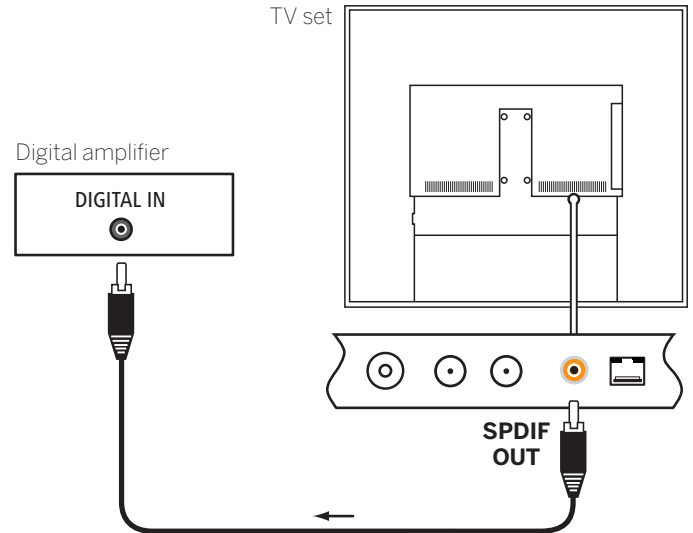

### Connecting analogue HiFi/AV amplifiers

Use a stereo cinch/jack adaptor cable to connect the analogue audio output **AUDIO OUT** to the analogue audio input of the amplifier:

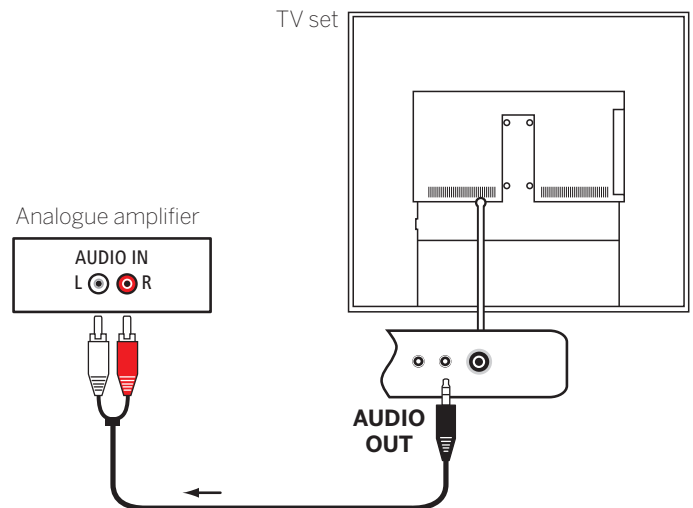

### Reproducing sound via an HiFi/AV amplifier

The sound reproduction via connected HiFi/AV amplifiers can be adjusted in the sound components wizard.

Further information on settings for the HiFi/AV amplifier you find starting from page 122.

## Audio playback from external devices

Connect external AV devices (e.g., MP3 player, DVD player) for sound reproduction to the AV inputs of the TV set.

### Connecting an external appliance (e.g. MP3 player)

Connect the output (jack receptacle) of the MP3 player via S-video adaptor<sup>†</sup> (**AVS**) or the VGA adaptor<sup>†</sup> (**PC IN**) to the **AVS** socket of the TV set.

Plug the adaptor plug into the **AVS** socket of the TV set so that the arrow on the plug is visible.

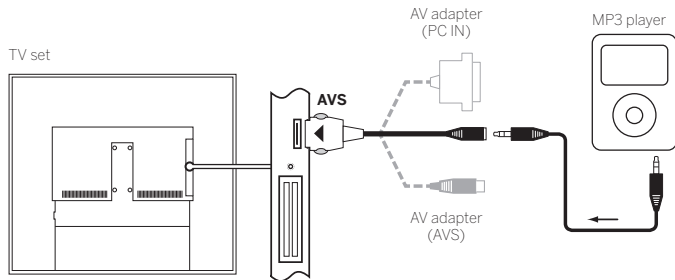

Connection example of an MP3 player

## Serial interface RS-232C (RJ12)

You can connect a home network system of different manufacturers (e.g. AMX, Crestron) to your TV set via the RS-232C (RJ12) interface.

As to the configuration of the RS-232C (RJ12) interface and for further information on the various home networking systems contact your dealer please.

### Select AV input

**i** The selection of the AV input for a device at the **AVS** socket (connection as described above) is describe here as an example. The procedure is similar to the selection of the other AV inputs.

HOME

**HOME:** Call **Home** view.



◀ ▶ ▲ ▼ Mark **Extras**,  
**OK** call Extras.

▲ ▼ Mark **AV selection**,  
**OK** call AV selection.



▼ ▲ Mark desired AV source,  
**OK** switch to AV source.

Start playback on the external device after selecting the AV input.

<sup>†</sup> Adaptor set is available as an accessory (see page 145).

## Operating Loewe units

### Using the remote control for the TV mode of the TV set

 Press the **TV key**, the LED above it will light for approx. 5 seconds.

### Using the remote control for a Loewe recorder

 Press the **STB key**, the LED above it will light for approx. 5 seconds.

### Using the remote control for a Loewe player

 Press the **VIDEO key**, the LED above it will light for approx. 5 seconds.



### Using the remote control for the radio mode of the TV set



 Press the **AUDIO key**, the display above it will light for approx. 5 seconds.

As long as a key is pressed, the LED for the selected operating mode lights up (**TV** – **STB** – **VIDEO** – **AUDIO**). This allows you to check which operating mode the remote control is set to every time you press a button.

The **factory setting** of the keys is described above (see also table in right hand column). The assignment of the buttons can be changed to suit the existing accessory devices (see right hand column).

### Set unit for sound control function on the remote control



The keys for the sound control functions Volume () and Sound on/off () are programmed ex-factory to interact with the TV set. The unit to be operated can be modified.

  Press the **TV key** and the numerical key simultaneously for minimum 5 seconds. The LED above the selected **TV** key flashes twice.

Function	Buttons	Unit
Audio Functions	TV + 3	Auro/AudioVision/MediaVision 3D
	TV + 4	Mediacenter
	TV + 5	<b>Loewe TV</b>
	TV + 6	Loewe TV with sound projector without system connection

### Setting the remote control for other Loewe devices

You can operate various Loewe devices with the remote control. The device keys **STB** – **VIDEO** – **AUDIO** can be reassigned to operate different Loewe devices.

  Press the required device key and the **STOP key** simultaneously for 5 sec. until the corresponding LED display flashes twice.

Then enter the two-digit device code from the list below. The corresponding LED indicator light flashes twice.

Unit	Code	Factory setting
Loewe ViewVision 8106 H	10	
Loewe Viewvision, Centros 21x2	12	
Loewe ViewVision DR+ DVB-T	13	
Loewe Auro 2216 PS/8116 DT	14	
Loewe BluTech Vision Interactive	15	
Loewe Sound Projector	17	
<b>SetTopBox (STB) data base</b>	<b>18</b>	<b>STB</b>
<b>Loewe TV - Digital radio</b>	<b>19</b>	<b>Audio</b>
Loewe Mediacenter	20	
<b>Loewe BluTech Vision 3D</b>	<b>21</b>	<b>VIDEO</b>
HDMI CEC mode	22	
Loewe AudioVision	24	
Loewe Individual Sound Projector ID	25	
Apple IR codes	26	
Apple IR codes (Apple TV-2G)	27	
Loewe Soundbox	28	
Loewe SoundVision	29	
Loewe AirSpeaker	30	
Loewe MediaVision 3D	35	
Restore defaults	99	

**i** The codes shown here only apply to direct operation of the auxiliary device device.

**i** The available codes may vary depending on the status of the firmware in the remote control.

## Teaching the remote control

By means of key code **18** (Set-Top Box data base) your remote control Assist may be taught for your Set-Top Box (e.g., decoder, external cable tuner). Thus, you spare yourself the use of several remote controls.

**i** For the use of 2-digit key codes see page 133.

The following options are available for teach-in:

- Entering a 3-digit code number
- Set-Top Box read-out
- Teaching individual keys
- Delete learned codes

**i** In the following, the **STB** key is dealt with as an example since device code 18 is preset for this key ex-works. Code 18 may also be assigned to the **AUDIO** and **RADIO** keys (see page 133); the following description applies accordingly.

### Entering a 3-digit code number

The **STB** key can be programmed directly by means of a device-dependent 3-digit code. You find a list of these codes starting from page 159.

  Keep the **STB** and **OK** keys depressed for five seconds. The LED above the **STB** key flashes twice.

Enter the 3-digit code from the list. The LED above the **STB** key lights up for 1 second.

**OK** end the programming mode. After a successful programming the LED flashes twice.

**i** When entering a wrong code number, the LED lights up for 2 seconds. Do this programming once again.

### Read-out of programmed Set-Top Box



The code of the currently programmed device on the **STB** key can be indicated by the remote control.

  Keep the **STB** and **OK** keys depressed for five seconds. The LED above the **STB** key flashes twice.

 Press **INFO** key.



The LED above the **STB** key shows the programmed code by flashing. The figure "0" will be indicated by flashing 5 times.

### Teaching individual keys

All keys (except the **TV**, **STB**, **VIDEO** and **AUDIO** device keys as well as the **V+/-** keys  and ) can be taught for the operation of units which are not contained in the integrated data base. The functions of the selected button are then completely or partially overwritten with the new codes.

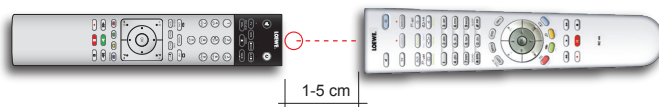
**i** Place the TV remote control and the remote control to be replaced in such a way that the infrared windows face each other at a distance of 1-5 cm (see sketch).



  Keep the **STB** and the **red key** simultaneously depressed for five seconds. The LED above the **STB** key lights up permanently.



Press key to be taught on the TV remote control.

The LED above the **STB** key flashes.



On the original remote control press the button which is to be taught.

The LED above the selected **STB** key flashes twice.

If the code is not correctly recognised, the LED above the **STB** key flashes ten times. Then repeat your entry on the original remote control. If necessary correct the allocation of the two remote controls. Continue with the other buttons as described above.



To end the teaching mode, press the **STB** key again.

**i** After 10 seconds without an entry the teaching mode is automatically terminated.

**i** It is possible that not all remote control codes can be taught.

**i** You can make notes of the functions you have assigned to the keys on page 161.

### Deleting individual key functions

You can delete the taught function of an individual button.

-   Press **STB** and **green key** simultaneously for five seconds. The LED above the **STB** key lights up permanently.



Press key to be deleted on the TV remote control.

The LED above the **STB** key flashes twice.

Continue with the deletion of other buttons as described above.

-  To end the deletion mode, press the **STB** key again.
- The LED above the **STB** key flashes once.

### Deleting all functions of the key for a device

You can delete all taught functions which you have set on the **STB** key.

-   Press **STB** and **yellow key** simultaneously for five seconds. The LED above the **STB** key flashes twice.

### Deleting all functions of the keys for all devices

You can delete all taught functions which you have set on the **TV**, **STB**, **VIDEO** or **AUDIO** buttons.

-   Press **STB** and **blue key** simultaneously for five seconds. The LEDs above the keys for the devices flash twice.
-

## Loewe Apps

Loewe provides various Apps for your mobile devices:

### Loewe Internet Radio App

**Loewe Internet Radio App** provides you with the Internet radio offers of vTuner for your Apple products iPhone, iPad or iPod touch (from iOS 3.0). Your personal settings such as the vTuner favourites are synchronised with those of the TV set after registering your Apple product via the Loewe Support homepage (see page 101).

### Loewe VideoNet App

The **Loewe VideoNet App** enables free and direct access to the best videos in the Web. The App streams live Podcasts, Screencasts and Web-Shows without loop route onto your iPad. You can use the Favourites function to add videos to your personal favourites list with just one click. In this way you can watch the latest episodes live. You can use the "Send-to-TV" function to send selected videos to your Loewe TV set and play them there.

This App is available for Apple iPad (from iOS 3.2) via the Appstore.

To use the full functionality, you need to connect the VideoNet App on your TV set (can be found in the **MediaNet** area) and the VideoNet App of your iPad to each other (pairing). You can find a precise description of the steps necessary in the instructions of the iPad-App under the point **Pairing**.

### Loewe Assist Media App

The **Loewe Assist Media App** is a powerful App, which can not only replace your remote control in your home network, but also **EPG** and **DR+** archive provided by the TV set to your iPad. You can also transfer the station list of your TV set to your iPad, programme timer entries, start an immediate recording and add personal favourites to the start screen of the App.

In the course of the **Loewe Assist Media app**, the keyboard of your iPad can be used with restrictions for inputting text on the screen (e.g. in the browser). Text which has been input is moved to the TV set after confirmation.

This App is available for Apple iPad (iOS 4.0 or higher) via the Appstore.

For the overview of the prerequisites for the use of the Assist Media app for the Apple iPad see page 137

---

## Overview of the prerequisites for the use of the Assist Media app for the Apple iPad

### 1. WLAN router and home network

A WLAN router must be connected and installed.  
See page 13 for further information.

### 2. The Loewe TV set is connected to the home network via LAN / WLAN

You reach the network setting of the Loewe TV set via **HOME** view → **System settings** → **Multimedia / Network** → **Network settings** → **Networking**.

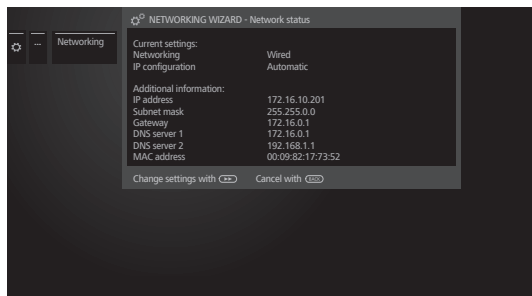

Select whether the TV device should be connected to the Internet using a LAN (cable) or WLAN (wireless) connection. Here you also see the name of the network and the IP address of the TV set. This address will be indicated in the **Assist Media App (Settings → Connect)** and is used to make a difference between the devices registered in the network.

Further information you find starting from page 114.

### 3. A digital Cable / Satellite connection (DVB-C/-S) is available

Loewe recommend a DVB-C- or DVB-S connection of your TV set. You have the possibility to fully use the **Assist Media App** for iPad. In case of analogue TV reception, **Assist Media** cannot fully use the EPG, for instance.

### 4. The DR+ Streaming settings are checked

Please set in the **DR+ Streaming** settings under **HOME** → **System settings** → **Control** → **more ...** → **DR+** → **DR+ Streaming** the first two items **Share DR+ archive with other devices** and **Also use other archives** to **yes**.



In the DR+ Streaming setting you can also set the name of the TV set under which it will be displayed in the App. After renaming please switch the TV set off and on again using the power switch.

Further information you find starting from page 106.

### 5. Creating an Apple ID

If it has not been done yet, create a user account (Apple ID) on your iPad in the **Settings** under item **iTunes & App Stores**.

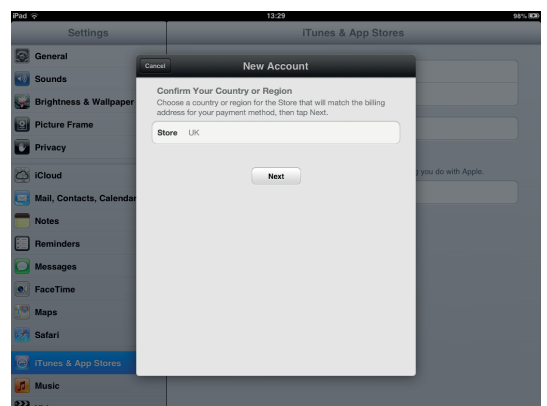

Follow the instructions.

You can then download the Loewe **Assist Media App** for iPad from the App Store.



## 6. Install Loewe Assist Media App

Open the **App Store**.



Enter the keyword **Loewe** in the browse list on the right above. Start searching by pressing on **Search**.

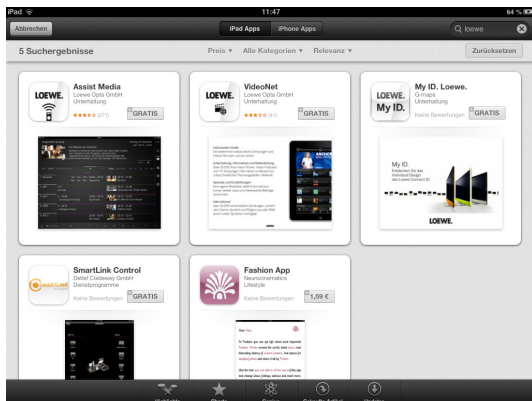
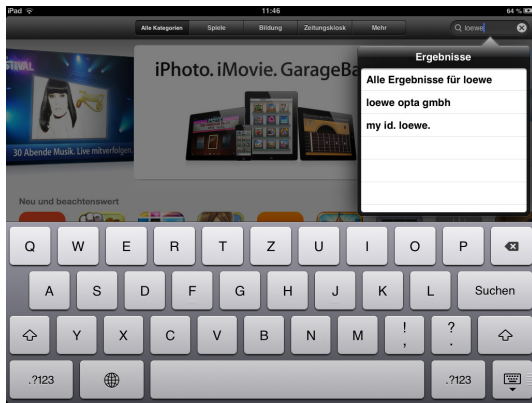

Install the **Assist Media** App by pressing on **FOR FREE**. Follow the instructions on the installation of the app.

## 7. Install the Assist Media App

Activate the location services for the apps **Assist Media** and **Maps** in your iPad under **Settings** → **Data protection** → **Location service**. This is essential for using country-specific functions. Thus, you can use the maxdome video service, for example.



Open the **Assist Media** app on your iPad. It scans your home network for Loewe TV sets. Follow the instructions and select the desired TV set.

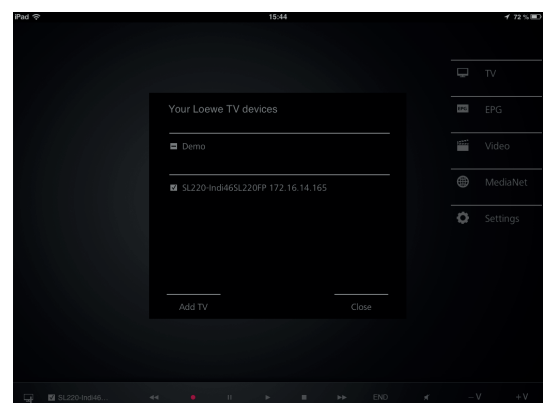

In another step, you choose which station list the app shall load: the unsorted main list or one of your personal lists. Thereafter, loading of the EPG starts. The app is available to you after a few minutes of loading time. Further EPG data packages are loaded in the background.



Problem	Possible cause	Remedy / Instructions
The TV set switches off automatically.	The <b>automatic shutdown</b> switches off the TV set to save energy after 4 hours of inactivity as soon as at least one signal input group is set up in the energy efficient mode <b>Home Mode</b> .	Using automatic shutdown is recommended for the purposes of energy saving and safety.
All menus are displayed in the <b>wrong language</b> .	The menu language was set incorrectly.	<b>Set the menu language:</b> Press <b>HOME</b> key. Call last menu item  (bottom left). Mark the fourth item from above in the following list and move to next column to the right. Call first list item with <b>OK</b> . Select the language and confirm it with <b>OK</b> .
General problems when connecting <b>external devices</b> via an <b>AV input</b> .	a) The <b>AV standard</b> is set incorrectly. b) The <b>Signal type</b> is set incorrectly.	a) Set the correct standard (see page 123). b) Set the correct signal type (see page 123). If <b>AV standard</b> or <b>Signal type</b> is set to " <b>Automatic</b> " then this can lead to false detections with non-standard signals. In this case standard and signal must be set according to the information in the operating manual of the external device.
With <b>Teletext</b> various <b>characters</b> are displayed incorrectly.	The wrong character set has been set in the <b>System settings</b> .	Set the correct character set: <b>System settings → Control → more ... → Standard Teletext → Character set → Standard</b> or select the appropriate character set.
Errors occurred when running a CA module.		Switch the TV set off. Remove the CA-module from the TV set. Wait a few seconds. Reinsert the CA module. Switch the TV set on again.
<b>No sound</b> via the external digital <b>audio amplifier</b> .	a) The external digital audio amplifier does not support the selected sound format (Dolby Digital, dts, MPEG). b) TV set and external digital audio amplifier are not connected with each other.	a) Set PCM stereo on the DVD player in the sound selection. For DVB stations switch <b>Language/Sound</b> b) Connect <b>SPDIF OUT</b> from the TV set to a <b>digital</b> input of the external digital audio amplifier and select the appropriate input to this.
A programmed <b>recording</b> was not made.	The provider deleted the programme from the EPG data, for example due to a programme change. The station from which the recording was made does not support <b>automatic time control (Accurate Recording)</b> .	Only the broadcasting organisations are responsible for transmitting data for the <b>automatic time control</b> . The availability of the appropriate data cannot be guaranteed.
There is no start or end of a programmed recording although the <b>automatic time control (Accurate Recording)</b> was used.	The transmission time of the program was delayed and the channel from which the recording was made has not updated the data.	Only the broadcasting organisations are responsible for transmitting data for the <b>automatic time control</b> . The availability of the appropriate data cannot be guaranteed.
No IP address will be issued to your TV set in spite of <b>automatic</b> IP configuration.	No DHCP server is working on your network.	Set up a DHCP server. Assign the IP addresses for the TV set <b>manually</b> .

Problem	Possible cause	Remedy / Instructions
Despite video or music file being played back, no sound can be heard.	<p>a) The TV set is set to mute or the volume has been turned down too much.</p> <p>b) An audio device that does not exist or that is not connected, is registered under <b>System settings → Connections → Sound components</b> (e.g., <b>HiFi/AV amplifier</b>).</p>	<p>a) Increase the volume by pressing the <b>V+ key</b> on the remote control for a longer time. This will also cancel any mute setting.</p> <p>b) Connect the audio device and switch it on. In the <b>Sound components wizard</b> change back to <b>TV speakers</b>.</p>
Although the file is visible on the media server, it is not displayed in the MediaPortal.	The file is not made available by your media server.	Change to your media server. For this, also read the section <b>Media server software</b> on page 143.
A media file that is displayed can not be played back.	The format of the file is not supported (see also limitations in section <b>File formats supported</b> on page 143).	No remedy.
Characters received in the WLAN code of the wireless router cannot be entered for the network configuration at the TV set.	The device does not support all special characters.	Change the WLAN key of the router.
When searching for wireless routers, no device is found.	The router is not ready for wireless communication.	Check your wireless router. Try to make the connection again a few minutes later.

Should there be any **interference** during **wireless** network operation such as **disruptions** during playback or **slow reactions** by devices to commands, you could try the following:























- Keep at least three metres **distance** from microwave ovens, bluetooth devices, mobile telephones and Wi-Fi compatible devices such as printers and PDAs.
- Change the active channel on the WiFi Router.

## Technical data

Type	Reference ID 55 	Reference ID 46 	Reference ID 40 
Part number	52424xxx	52422xxx	52421xxx
Device dimensions without stand (W x H x D) in cm	126.4 x 105.3 x 7.3	107.0 x 94.4 x 7.3	93.8 x 87.1 x 7.3
Weight without stand (approximate) in kg	45.5	36.5	30.5
Display technology	Full HD LCD with edge LED backlight technology		
Screen diagonal (in cm) / Picture format	140 / 16:9	117 / 16:9	101 / 16:9
Resolution (in pixels) / Motion Response	1920 x 1080 / 400 Hz		
Contrast (static / dynamic)	5,000 : 1 / 5,000,000 : 1		
Viewing angle (horizontal / vertical)	178° / 178°		
Power consumption On-Mode max. (W) (Audio output 1/8 of the maximum value)	161	138	126
Power consumption in Standby Mode (W)	120	109	96
Power consumption in Standby Mode (W)	0.47	0.47	0.47
Power consumption when set is switched off (W)	0	0	0
Ambient temperature (Celsius)	5° – 35°		
Relative humidity (non-condensing)	20 – 80%		
Air pressure	800 – 1114 hPa (0 – 2000 m above sea level)		
Chassis designation:	SL 220		
Power supply:	220 V – 240 V/50–60 Hz		
Tuner:	terr./cable: Satellite:	VHF/Hyperband/UHF 4 levels: 13/18V/22kHz / 16 levels: DiSEqC 1.0 / single-cable system: EN 50494	
Range:	terr./cable: Satellite:	Terr./cable: 45 MHz up to 860 MHz Satellite: 950 MHz up to 2150 MHz	
Station storage locations incl. AV and radio:	5000		
TV standards:	analogue: digital:	B/G, I, L, D/K, M, N DVB-T/T2, DVB-C, DVB-S/S2	
Colour standards:	SECAM, PAL, NTSC, NTSC-V, PAL-V (60 Hz)		
Sound standards:	analogue: BG, DK, MN: BG, I, DK: L, L1: digital:	Mono, Stereo, Dual channel FM-A2 FM-Nicam AM-Nicam Mono, Stereo, Dual channel, PCM, Dolby Digital, Dolby Digital Plus, Dolby Virtual Speaker, DTS, Dolby Digital Pulse	
Audio output power (music/sine):	2 x 40W + 1 x 80W (music) / 2 x 20W + 1 x 40W (sine)		
Teletext:	FLOF Level 2.5		
Page memory:	2000		

## Function of the connections

The following table shows the name, type and function of the ports.

Designation	Type	Function / Signal
 220-240V~ 50/60 Hz	Mains socket	220-240 V ~ 50 / 60 Hz Supply voltage
	RJ12	Data I/O: serial interface
	Mini-DIN	Rotating stand control (Positioning accuracy 1.5°)
	Jack 3.5 mm	Connection for IR station
	Jack 3.5 mm	Audio OUT: analogue audio output L / R
	Cinch (black)	Audio IN: max. 2Vrms: Centre audio input (analogue)
	Mini AV	Video IN: Y/C (S-VHS/Hi 8) CVBS (VHS/8 mm) RGB L/R Audio IN:
 5 V $\leftrightarrow$ 180 mA	IEC socket	75 Ohm / 5 V / 80mA: Antenna (analogue) / Cable (analogue) / DVB-T/T2 / DVB-C
 13/18V $\leftrightarrow$ 500 mA max. 	F socket (2x)	75 Ohm / 13/18 V / 500mA: ANT-SAT DVB-S/S2
	Cinch (orange)	SPDIF OUT: Digital audio output
	RJ-45	Audio OUT: Multi-sound (digital)
   	HDMI type A (4x)	Digital Video/Audio IN (HDMI1, HDMI2, HDMI3, HDMI4): Digital video and audio
	RJ-45	Ethernet / Fast Ethernet: Network interface
	USB type A (3x)	USB 2.0 (max. 500mA): Multimedia files/software update
	Cinch (orange)	SPDIF IN: Digital sound input
	Mini AV	with S-video adaptor: Y/C (S-VHS/Hi 8) CVBS (VHS/8 mm) with VGA adaptor: PC/STB video signal <sup>1)</sup> Y/C (S-VHS/Hi 8)
	Jack 3.5 mm	Headphones 32–200 Ohm
	CI Slot (2x)	Common Interface: Slot for CA module

<sup>1)</sup> For compatible picture signals, see table on page 144.

## Media

### File formats supported

#### Pictures: JPEG, PNG

**Audio:** **MP3, M4A** (AAC LC), **WMA** (without lossless), **FLAC, WAV (PCM)**

**Video:** **AVI** (MPEG-1/2, XviD, AC3, MP3), **WMV** (WMV9, VC-1, WMA9, WMA Pro), **MP4** (XviD, H.264/MPEG-4 AVC, AAC LC), **MOV** (H.264/MPEG-4 AVC, AAC LC), **MKV** (H.264/MPEG-4 AVC, AC3), **FLV** (H.264/MPEG-4 AVC, H.263, MP3, AAC LC), **MPG** (MPEG-1, MPEG Audio), **TS/PS** (MPEG-2, H.264/MPEG-4 AVC, MPEG2 Audio, AC3), **VOB** (MPEG-2, MPEG2 Audio, AC3)

 **H.264/MPEG-4 AVC** upto Profil High (Level 4.2)

### Ethernet (wired network)

Supported standards: 10 Mbit/sec Ethernet (10Base-T), 100 Mbit/sec Fast Ethernet (100Base-T)

### WLAN (wireless network)

#### Standards supported:

IEEE 802.11b/g/n

#### Frequency range used:

2400-2483,5 MHz and 5180-5730 MHz

#### Types of encoding that are supported:

WEP 64 and 128 Bit (ASCII and HEX), WPA PSK, WPA2 AES

### Supported home network standard

Universal Plug and Play Audio / Video (UPnP AV)

### Media server software

To play multimedia contents from devices in your home network, you require media server software which makes the relevant files available to you. Handling of individual files depends on the technical properties and also on the media server software used.

You can download a test version of the **TwonkyMedia** Mediaserver from our homepage. With your TV set, you have also acquired the option of obtaining a free licence for the currently available version of the Twonky media server. Alternatively, you can also use other media servers, e.g., the **Windows Media Player (WMP) from Version 11**.

For communication with your PC, certain **port addresses** of the network connection are required. They may not be blocked by a firewall if there is one, otherwise this could cause serious connection errors. Windows Media Player 11 requires the port addresses 1900 and the block of 10280 up to and including 10284 (all for UDP) as well as 2869 and 10243 (both for TCP). For TwonkyMedia the port addresses 1030, 1900 and 9080 (all for UDP) and 9000 (for TCP) must be available.

Other ports to be kept free depend on the operating system you are using.

Contact your network administrator about configuring the firewall.

### USB stick - requirements

USB sticks tested by Loewe and compatible in type and format can be ordered from the Loewe dealer using the article no. 90456.900.

If you would like to use your own USB stick, please follow these tips/conditions:

- Formatting in FAT32.
- Just one partition.
- Do not use encrypted USB sticks.
- Do not use USB sticks that simulate a CD ROM drive.
- There may be no hidden files on the device.
- For some types of device, the construction of the USB stick is significant. Maximum dimensions in mm: 70x20x10.
- If in doubt, the USB stick should be formatted as "FAT32" without "extended attributes".

 The key number **3001** invalidates an identification number and thus the parental lock. Please keep in a safe place.

## Signals via AVS (PC IN) / HDMI

The following table lists the compatible signals which your TV set can show via the **AVS (PC IN)** connection or via the HDMI connections (**HDMI1, HDMI2, HDMI3, HDMI4**).

Set the output signal on your PC, HDMI or DVI device so that it matches one of the signals in the table.

Format	Horizontal	x	Vertical	Frame frequency	connection
480i60	720	x	480i	60Hz	PC IN, HDMI
576i50	720	x	576i	50Hz	PC IN, HDMI
480p60	720	x	480p	60Hz	PC IN, HDMI
576p50	720	x	576p	50Hz	PC IN, HDMI
	1440	x	480p	60Hz	HDMI
	1440	x	576p	50Hz	HDMI
720p50	1280	x	720p	50Hz	PC IN, HDMI
720p60	1280	x	720p	60Hz	PC IN, HDMI
1080i50	1920	x	1080i	50Hz	PC IN, HDMI
1080i60	1920	x	1080i	60Hz	PC IN, HDMI
1080p24	1920	x	1080p	24Hz	PC IN, HDMI
1080p25	1920	x	1080p	25Hz	PC IN, HDMI
1080p30	1920	x	1080p	30Hz	PC IN, HDMI
1080p50	1920	x	1080p	50Hz	PC IN, HDMI
1080p60	1920	x	1080p	60Hz	PC IN, HDMI
VGA	640	x	480	60Hz	PC IN, HDMI
SVGA	800	x	600	60Hz	PC IN, HDMI
XGA	1024	x	768	60Hz	PC IN, HDMI
WXGA	1360	x	768	60Hz	PC IN, HDMI
SXGA	1280	x	1024	60Hz	PC IN, HDMI

## Signal input groups

In your TV set the signals are sorted in various signal input groups according to their source. In addition to the source, the type of signal is also distinguished.

For each signal input group, there are individual values for the picture settings (see page 87).

Signal group name	Signal source/Signal type
SD Analog	cable analogue, interfaces AV, AVS, PC IN <sup>†</sup> (SD)
SD Digital	DVB (SD), DR+ (SD), MPEG-Encoder
SD Media Player	full screen display of SD videos via USB, Network, VOD and media centre (incl. HbbTV media centre)
SD HDMI	Playback of SD video via HDMI, e.g., DVD player
HD Analog	PC IN <sup>†</sup> (HD)
HD Digital	DVB (HD), DR+ (HD)
HD Media Player	full screen display of HD videos via USB, Network, VOD and media centre (incl. HbbTV media centre)
HD HDMI	Playback of HD videos via HDMI, e.g., Blu-Ray player
3D HD	3D playback of HD videos (analogue or digital)
3D SD	3D playback of SD videos (analogue or digital)
3D Media Player	full screen display of 3D videos (SD/HD) via USB, Network, VOD and media centre (incl. HbbTV media centre)
3D HDMI	Playback of 3D videos via HDMI, e.g., 3D Blu-Ray player
Photo Player	Playback of Photos via USB and network
Browser	Display of Web sites in the Browser (incl. Media apps)
VGA	PC IN <sup>†</sup> (PC) or HDMI (PC)

<sup>†</sup> with VGA adaptor on AVS connection.



## Accessories

The following accessories are obtainable from your Loewe dealer.

### Mounting options:

Various options are available for mounting your TV set on the floor and wall.

You will find an overview of the available mounting options on page 147.

### Loewe Speaker Reference ID:

Complete your Reference ID to an extraordinary sound system. The Speakers Reference ID reproduce even the most difficult sounds with incredible precision and the D'Appolito arrangement leads to an unprecedented spatial resolution. Used high-tech material such as ceramics in the speakers creates an unparalleled listening experience. To operate the Speaker Reference ID an additional **Loewe Subwoofer 800** is required.

### Loewe 3D Blu-ray player:

With the Loewe Blu-ray player BluTech Vision 3D you're fully kitted out to watch Blu-ray discs with 2D and 3D material. With the Loewe system integration you control BluTech Vision 3D and your Loewe TV set simultaneously using the Assist remote control.

### Loewe MediaVision 3D:

Loewe MediaVision 3D is partly an audio system: It plays your favourite sound via the integrated iPod/iPhone dock and automatically identifies songs or film music with the MusicID function. Loewe MediaVision 3D is also a home cinema system, ensuring a perfect all-round audio visual experience - thanks to the fast and precise Full-HD 3D Blu-ray drive and a 5.1 decoder. Not least, Loewe MediaVision 3D is a colourful feast for the eyes: because it can be beautifully customised by individual intarsia.

### Loewe 3D glasses:

The Loewe 3D shutter **Active 3D Glasses** give you clear 3D enjoyment and are compatible with all Loewe 3D flat screen TVs.

### Loewe Assist Easy:

The reduced focused design of Loewe Assist Easy remote control guarantees survey at first sight, nevertheless all important functions are controllable with one hand. Therefore it is the optimal control centre of the new user interface Loewe Assist Media. As a multifunctional remote control it is able to control further Loewe products in addition.

## Upgrade kits / conversion kits / cables

### USB extension (part no. 70167080):

To ensure the accessibility of the USB connections or to be able to insert USB sticks with a large housing, a USB extension can be connected to the TV set. You can purchase the USB extension via your Loewe dealer.

### Converter Digital Audiolink/Audiolink (part no. 71600080):

The digital Audiolink/Audiolink convertor allows you to connect your TV set to audio devices with a 25-pole AUDIO LINK socket.

To connect the convertor you require additionally an Ethernet cable with RJ45 plugs, category 5e or higher with a length of at least 1m and maximum 15m.

### Adaptor Set AV SL 2xx (part no. 71678080):

The Loewe adaptor set contains three AV adaptors: The Loewe **Scart** adaptor allows you to extend your TV set by adding an AV socket to connect, e.g., DVD players or DVD recorders. The **VGA** adaptor enables the connection of a PC monitor or a Set-top box. By means of the **S-video** adaptor you connect your video camera to the TV set. Additionally to the video inputs, the adaptors for VGA and S-video are equipped with a 3.5mm stereo jack socket for analogue sound.

### Loewe Scart Adaptor (part no. 71480080):

The Loewe scart adaptor allows you to extend your TV set by adding an AV socket to connect, e.g., DVD players or DVD recorders.

## Equipment variants

The equipment of the individual set variants and their upgrade/conversion possibilities is listed in the table below.

Set variants	Reference ID 55	Reference ID 46	Reference ID 40
DR+	●	●	●
DVB-T/T2/C Twin	●	●	●
DVB-S/S2 Twin	●	●	●
Digital audio decoder	●	●	●
HbbTV	●	●	●
WLAN	●	●	●
RJ12	●	●	●
Motor Unit connection	●	●	●
IR Link	●	●	●
LED light module	○	○	○

- ex factory
- depending on the type of TV set
- not available

## Integrated features

See the rating plate on the rear of the set for the precise product designation.

The precise features are listed in the **Integrated features** item under **Extras → Special functions** (see page 83).

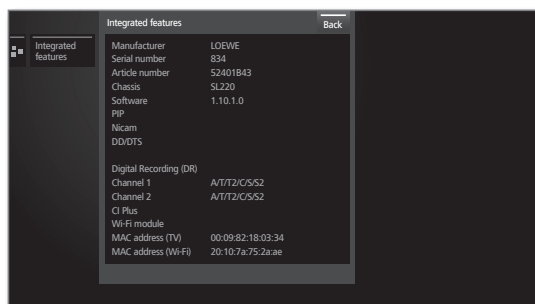

## Mounting options

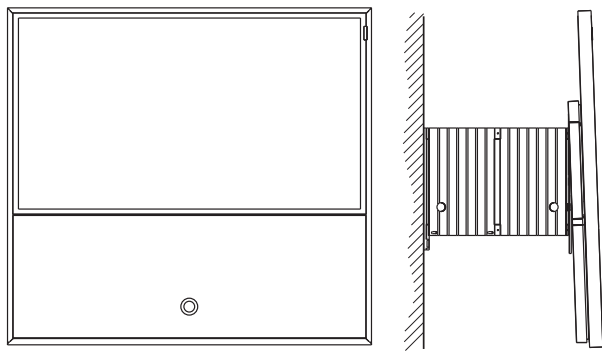

WM Flex R ID 40-55

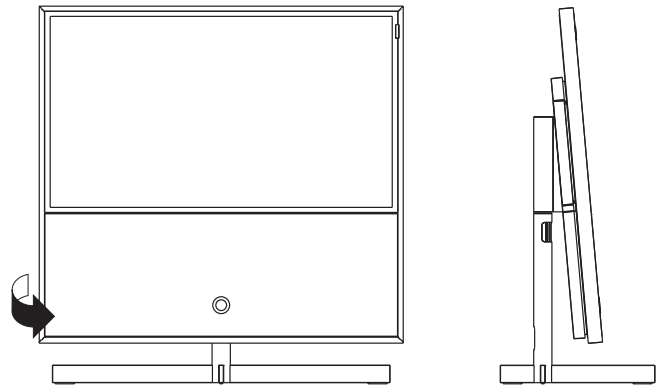

Floor Stand R ID 40/46 Dynamic

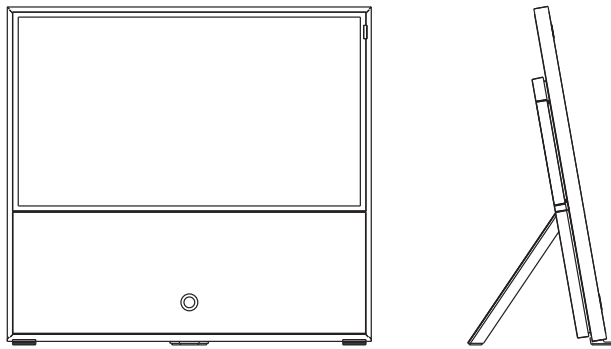

Floor Stand R ID 40-55

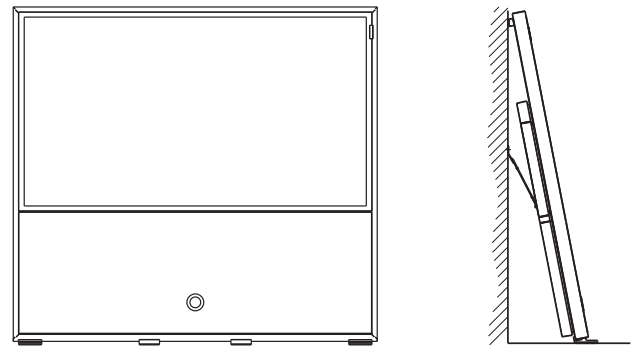

Floor Wall Mount Kit R ID 40-55

## Environmental protection

### Energy consumption

Your TV set is equipped with an eco-standby power supply. In the standby mode, the power consumption drops to low power (see Technical Data on page 141). If you want to save even more energy then switch the device off with the mains switch. Please also note that the EPG data (Electronic Programme Guide) is lost under certain circumstances and possibly programmed timer recordings **cannot** be carried out via the TV set.

**i** The TV set will be completely separated from mains only when you unplug the mains cable.

The power consumed by the TV set during operation depends on the energy efficiency preset in the initial installation (see page 20) or on the setting in the System settings (see page 87).

If you activate the automatic dimming (see page 86), your TV picture will adapt to the ambient brightness. This reduces the power consumption of the TV set.

If the TV is not operated for 4 hours (adjustment of volume, programme change, etc.) the TV will automatically switch to stand-by mode to save energy. A prompt to terminate this shutdown process appears one minute before expiry of the 4 hours. The automatic shutdown is only active in the energy efficiency mode **Home Mode**.

### Cardboard box and packaging

You have made a decision to purchase a high-quality technical product with a long service life. For disposal of the packaging, in accordance with national legislation we have paid a fee to a commissioned recycler to pick up the packaging from the dealer.

### The device



The EU directive 2002/96/EC regulates the proper way to recycle, handle and utilise used electronic devices. **Old electronic appliances** must therefore be disposed of separately. **Never** dispose of this device in normal **domestic waste!**

You can hand in your old unit free of charge at identified collection points or to your dealer if you buy a similar new unit. Other details about reacceptance (also for non-EU countries) are available from your local administration.

### Batteries



The batteries supplied as initial equipment do not contain any pollutants such as cadmium, lead, or mercury. In accordance with the Battery Directive, used batteries should **no** longer be disposed of in the **domestic waste**. Dispose of your batteries at no charge in the **collection containers** which are set up for this purpose in retail stores.

## Licences

Manufactured under licence from Dolby Laboratories. "Dolby", "Pro Logic" and the double-D symbol are trademarks of Dolby Laboratories.



This set contains a software which is based partly on the work of the Independent JPEG Group.

iPad, iPhone, iPod are registered trademarks of Apple Inc. in the USA and other countries.

HDMI, the HDMI logo and High-Definition Multimedia Interface are trademarks or registered trademarks of HDMI licensing LLC in the United States and other countries.



This product includes software developed by the OpenSSL Project for use in the OpenSSL Toolkit (<http://www.openssl.org>).

This software is provided by the OpenSSL project "as is" and any expressed or implied warranties, including, but not limited to, the implied warranties of merchantability and fitness for a particular purpose are disclaimed. In no event shall the OpenSSL project or its contributors be liable for any direct, indirect, incidental, special, exemplary, or consequential damages (including, but not limited to, procurement of substitute goods or services; loss of use, data, or profits; or business interruption) however caused and on any theory of liability, whether in contract, strict liability, or tort (including negligence or otherwise) arising in any way out of the use of this software, even if advised of the possibility of such damage.

This product includes cryptographic software written by Eric Young ([ey@cryptsoft.com](mailto:ey@cryptsoft.com)).

This product includes software written by Tim Hudson ([tjh@cryptsoft.com](mailto:tjh@cryptsoft.com)).

This product contains software which was developed by third parties and / or software which is subject to GNU General Public License (GPL) and/or GNU Lesser General Public License (LGPL). You can pass on and modify them in accordance with Version 2 of the GNU General Public License or optionally every later version which is published by the Free Software Foundation.

The publication of this program by Loewe is carried out WITHOUT ANY GUARANTEE OR SUPPORT, particularly without an implicit guarantee concerning MARKET MATURITY or the USABILITY FOR A SPECIFIC PURPOSE. Details can be found in the GNU General Public License. You can obtain the software via the Loewe customer service department. The GNU General Public License can be downloaded from: <http://www.gnu.org/licenses/>.

## 0-9

**24p motion picture display:** Movies released on Blu-ray Disc support the 24p motion picture display. The Blu-ray player transfers the original film format to the television with 24 frames per second. The DMM (DigitalMovieMode) set in the factory calculates and inserts additional intermediate pictures, which suppress film jerking typical for the cinema, thereby providing for a smooth motion sequence.

## A

**Accurate Recording:** See **Automatic time control**.

**Administrator:** Person who administers the network, i.e. takes care of setting up and maintaining all components belonging to the network.

**Active antenna:** An antenna with its own power supply or amplification which can improve the reception in areas with a poor coverage.

**ARC:** Abbreviation for **Audio Return Channel**.

**Audio Return Channel:** The audio return channel which was introduced with the **HDMI Standard 1.4** is used when an audio system with audio (pre) amplifier, e.g. Loewe MediaVision 3D, is connected to a TV set via HDMI. The digital audio signal of the TV set (e.g. the sound of the current TV program) can be transferred to the audio amplifier via the audio return channel of the HDMI cable. Thus the same cable which is normally responsible for transferring image data from a connected media player to the TV set transfers the audio data in the opposite direction. In this way, the audio return channel makes the cinch cable, which has previously been required in addition to the HDMI cable, redundant.

**Automatic time control:** Also called **Accurate Recording**. Similar to **VPS** for analogue stations the automatic time control monitors the start and end times of programmes from DVB stations. If these times deviate from the data programmed in the timer data, the running time of the recording is adapted automatically. The automatic time control is not supported by all DVB stations.

**AV socket:** Socket for audio and video signals.

**AV sources:** Audio/Video source.

**AVI:** Abbreviation for Audio Video Interleave, a video container file format developed by Microsoft. A single AVI video file can contain several audio, video and text data streams (thus the name container format).

**AVS:** Audio/video sockets on the side of the TV set (cinch and mini-DIN).

## B

**Band:** Name for a transmission range.

**Blu-ray Disc:** The follow-up format of **DVD**. The contents of about five DVDs fit onto one Blu-ray Disc (abbreviated BD). Therefore, the Blu-ray disc provides enough space for high-resolution images and multi-channel sound formats.

**BMP:** Abbreviation for Bitmap, a grid graphics format designed for Microsoft Windows and OS/2 that is wide spread and therefore supported by almost every popular graphics software package without any problems.

## C

**CA Module:** The **Conditional Access module** contains the coding system and compares the transmitted code with the one on the **Smart Card**. If they match, the appropriate stations or programmes are decoded.

**CEC:** Abbreviation for Consumer Electronics Control. CEC provides universal component control functions for entertainment electronics devices (e.g. System standby, One Touch Play). CEC is referred to by Loewe as **Digital Link HD**.

**Channel (WLAN):** Devices that want to communicate with each other have to use the same WiFi channel. In Europe the WiFi frequency band is currently divided into 13 channels.

**Cinch cable:** Cable for transmitting sound or pictures.

**CI slot:** See **Common Interface**.

**Client:** Also called network client, describes an end device such as your TV set that is connected to the network and gets data from a (media) server to make it accessible to the user.

**Common Interface:** The Common Interface (CI slot) is a standardised interface. By inserting suitable decoding modules (**CA modules**) and a **Smart Card** coded digital programmes can be used.

**Common Interface Plus:** CI Plus is an advancement of the **Common Interface** standard. CI Plus slots are in principle downward compatible to the previous CI standard, i.e. CA modules and Smart Cards according to the past CI standard can continue to be used in CI Plus slots, as far as the programme provider permits this. Additionally, extended regulations apply however to CI Plus.

**Component:** See **Component connection**.

**Component connection:** Also referred to as **Component**. Connection where the video signal is transferred via three separate (Cinch) connections. It comprises the brightness signal **Y** as well as the colour difference signals **Pb** (blue component) and **Pr** (red component).

**Conditional Access module:** See **CA module**.

## D

**Decoder:** Analogue, coded TV signals are passed through a decoder and made visible again.

**DHCP:** Abbreviation for Dynamic Host Configuration Protocol. DHCP allows automatic assignment of IP addresses with the aid of a DHCP server.

**DHCP server:** Network service which takes care of automatic assignment of **IP addresses** to clients.

**Digital Link HD:** System for controlling units via the HDMI connection of the Loewe TV set when they have been set up in a covered position.

**DMM:** Abbreviation for Digital Movie Mode. Whether a studio recording, live broadcast, or feature film – the broadcast images are always displayed optimally. Still images are reproduced in all their sharpness and tranquillity. By creating intermediate images, DMM enables perfect studio quality, even with quick movements.

**DNC:** Abbreviation for "Digital Noise Control". Weak TV signals (analogue) can generate disruptive picture noise. DNC adjusts the effect of digital noise reduction to the picture contents.

**DNS:** Abbreviation for Domain Name System. Readable names (e.g. www.loewe-int.de) are assigned to numerical **IP addresses**. DNS servers are responsible for the resolution of readable addresses into the corresponding IP addresses.

**Dolby Digital:** Digital multi-channel sound. The digital standard for high quality home movie systems. The individual channels are broadcast separately in this standard. The three front channels right, left and centre, the two surround channels right and left and the external subwoofer channels are called a 5.1 signal.

**Dolby Pro Logic:** Analogue multi-channel sound. Converts a Dolby-coded stereo signal into a surround sound. This usually contains four channels (front left, centre, front right, surround channel). A special subwoofer channel is not generated in this method.

**Dolby Pro Logic II:** Analogue multi-channel sound. Dolby Pro Logic II is a further development of **Dolby Pro Logic**. This method generates a 6-channel spatial sound from a stereo or Pro-Logic signal (front left, centre, front right, surround left, surround right, subwoofer).

**Dolby Surround:** An analogue surround sound system which uses a matrix coding to fit four sound channels into two sound tracks.

**Dolby Virtual Speaker:** The Dolby Virtual Speaker technology simulates the surround playback of a real 5.1 channel playback with only two speakers.

**DRM:** Digital Rights Management. Processes to control copyright protected data. To be used correctly, DRM protected contents require not only a DRM capable device but also the possession of a license issued by the provider (to be paid for).

**DTS:** Digital Theatre Systems; Digital multi-channel audio.

## D (continue)

**DVB-C/-S/-T:** Digital Video Broadcasting stands for digital television. Technical DVB is the standardised process for transmitting digital content (television, radio, multi-channel audio, room sound, **EPG**, Teletext, and other supplemental services) through digital technology. **CST** for terrestrial or antenna distribution.

**DVD:** Abbreviation for Digital Video Disc and later Digital Versatile Disc.

**DVD preceiver:** Combi device of DVD player and radio without integrated amplifier.

**DVI:** Digital Visual Interface, is an interface for transmitting digital video and graphic data (without audio).

**Dynamic contrast ratio:** Here the light intensity of the display is adapted in case of a high black content in the picture. The so-called backlights are dimmed automatically and the contrast ratio increases temporarily, i.e. dynamically.

## E

**Electronic Programme Guide:** See **EPG**.

**EPG:** Electronic Programme Guide is the electronic variant of a printed TV guide. Using the EPG you can watch the TV programme of the TV station, transfer the appropriate data. The list of programmes contains the title, beginning and end and duration of the programme. In addition brief descriptions of the content of the programmes are also displayed.

**Ethernet:** Cable linked data net technology for local networks (LANs). Also covers standards for e.g. plug connectors and transfer speeds.

**Euro AV socket:** Interface for connecting video devices to a TV set. This socket is also referred to as Scart socket.

**Exif:** Standard format for additional data with modern digital cameras, e.g. date and time, aperture, light sensitivity, alignment of the camera (portrait/landscape).

## F

**FLOF:** Full Level One Facilities. Teletext system in which names and numbers of the jump destinations are transmitted in the bottom line on every page. This guides the reader to related topics for example. An information about which pages exist and which pages have sub-pages is not available in FLOF.

## G

**Gateway:** Transition to another network; in this case connection from the home network to the Internet.

The network device that establishes this connection is normally used as a standard gateway. As a rule, the DSL router also represents the Internet gateway.

## H

**HbbTV:** HbbTV (Hybrid broadcast broadband television) is an industry standard that offers an open platform for technology that is not dependent on manufacturers. HbbTV combines TV programmes with online services seamlessly over broadband Internet (DSL).

**HDCP:** High-bandwidth Digital Content Protection. Coding system provided for the **DVI** and **HDMI** interfaces for secure transmission of audio and video data.

**HDMI:** High Definition Multimedia Interface, represents a newly developed interface for the fully digital transfer of audio and video data.

**HD Ready:** A quality seal that is awarded to products that are capable of displaying high-definition television (**HDTV**).

**HDTV (HD):** High Definition Television is a collective term, designating a series of high-resolution television standards.

**High and low band:** Transmission ranges for satellites.

**Host:** Computer that the server services are provided from, i.e. that makes data available. Refer also to media server.

## I

**ID3 tags:** Additional information for MP3 and WMA audio files. Information about the singer, title, album and album cover can be saved here among other things. This data is then processed by the PC using an ID3 tag editor.

**IP address:** IP addresses (Internet Protocol Addresses) are used to identify devices in an Internet Protocol (IP) network. IP addresses are made up of four groups of numbers of three digits each.

**IR-Link:** The IR Link function allows the operation of accessory devices with concealed installation made by other manufacturers via the Loewe TV set. The infrared sensor required for this is available as an accessory and can be connected to the IR-Link connection of the TV set.

## J

**JPEG/JPG:** Joint Photographic Experts Group is a committee, which has developed a standardised method for the compression of digital images. This method JPEG (**JPG** for short), named after the committee, is a commonly used graphic format for photos.

## L

**LAN:** Abbreviation for Local Area Network. Mainly used as a name for networks with cabling (Ethernet).

**LCD:** Liquid Crystal Display.

**LCN:** Logical Channel Numbers. In stations with LCN, the channel location number belonging to the station is also transmitted by the provider. The stations are sorted according to these channel location numbers.

**L-Link:** Intelligent system connection between Loewe devices for the automatic exchange of information. Makes the operation of TV and Loewe system components even more convenient.

**LNB/LNC:** The crucial electronic component of a satellite antenna is referred to as an LNB (Low Noise Block Converter). It is mounted in the focal point of a parabolic antenna. The designation **LNC** (Low Noise Converter) indicates that conversion to a lower intermediate frequency takes place. The supplemental block in the LNB refers to the fact that a whole frequency range (a block) is converted in each case.

## M

**MAC address:** Hardware address of a network adaptor, e.g., the network card in the PC. It is issued permanently by the manufacturer and is used to uniquely identify devices in networks.

**Mbit/sec:** Information about the transfer rate in networks in megabits, i.e. millions of characters per second. With WLAN the maximum speed is 11 (IEEE 802.11b), 54 (IEEE 802.11g) or 300 (IEEE 802.11n) Mbit/sec, in wired networks 10 Mbit/sec or 100 Mbit/sec (Fast Ethernet).

**Media Server:** Stands for the device on which multimedia content is stored, but is also the name for the service provided by the device that makes this data available to the network.

**Modulator:** Transmitter in the video or DVD recorder so that the devices can receive signals via the tuner of the TV device.

**Mono:** Single channel sound.

**MP3:** Data format for compressed audio files.

**MPEG:** Digital compression method for video.

**Multimedia content:** Videos, music files and photos are grouped together under this term.

## N

**NAS:** The term describes a hard disk which is independently linked to the network (i.e. without a PC).

**Network ID:** NID refers to the so-called programme ID number, also known as network ID – a number between 0 and 8191. This specification is necessary in specific cable networks of some countries. Then only DVB signals of this station network are searched for.

**NICAM:** Audio standard. Is used in Denmark, England, France, Sweden, and Spain.

**NTSC:** American colour standard, stands for National Television Standards Committee.

## P

**Page Catching:** For teletext, refers to marking and calling a page number.

**PAL:** European colour standard, stands for phase alternation line.

**PCM:** Pulse Code Modulation for digital sound.

**Picture in Picture:** See **PIP**.

**PIP:** Picture in Picture; a function which displays two pictures on the screen.

**Pixel:** Also called picture element or pel. Denotes both the smallest unit of a digital graphic grid and its display on a screen with grid control.

**Pixel error:** A pixel error is a defective pixel, usually on an LCD. Pixel errors may be caused by production errors. They are expressed for example by a constantly lit pixel or a constantly black pixel. Single defective pixels however are excluded from a guarantee.

**PNG:** Abbreviation for Portable Network Graphics, a freely available grid graphics format for loss-free compression.

**Port:** It allows assignment of data packages to various services which are running on one device under the same network address.

**Powerline:** Powerline designates a type of wired network connection in which data is transferred via the domestic electricity network using optionally available adaptors.

**Progressive JPEG: Progressive JPEGs** are built up gradually. The quality of the picture increases progressively during the loading process.

**ProScan/Progressive Scan:** Progressive Scan (abbr. PS) or full picture method is a technique in the picture build-up of monitors, TV sets, beamers, and other display devices in which the output device is not sent line interlaced half pictures – unlike in the interlace technique – but real full pictures.

**PSK:** Clients that wish to connect to a wireless network secured with PSK must know this key.

## R

**RGB:** Colour signals Red, Green and Blue.

**Router:** Device for connecting several networks, e.g., home network and Internet.

## S

**Satellite tuner:** Receiver for satellite programmes.

**SDTV:** Standard Definition TeleVision.

**SECAM:** French colour standard, stands for Séquentiel à mémoire.

**Set-top box:** Set-top box (STB for short) refers to a device in entertainment electronics which is connected to another device, usually a TV set, and offers the user additional functional options.

**Signal input group:** Depending on the applied signal, the signal sources are divided into different groups.

**Signal strength:** Strength of the received antenna signal.

**Signal quality:** Quality of the incoming antenna signal.

**Smart Card:** The Smart Card is an electronic chip card issued by the respective programme provider or by the certification free Pay TV operators. It contains the code which is decoded by the **CA module**.

**Static contrast ratio:** Describes the difference between the brightest and darkest picture display.

**Stereo:** Dual channel sound.

**Switch:** Device for connecting several computers to a network.

**Switching voltage:** Video devices supply this voltage to switch the TV set to playback.

**Symbol rate:** Specifies the transmission speed for data transmission.

## T

**Terrestrial:** In data transmission a wireless transmission that does not use satellites as intermediate station is referred to as terrestrial.

**TFT:** Thin Film Transistor. One widely distributed application is control of liquid crystal flat screens, for which a signal transistor is used for each pixel. This design of display is also referred to as active matrix, however it is frequently also referred to as TFT display.

**Tuner:** Another term for receiver.

## U

**USB:** Universal Serial Bus. Serial bus system for connecting external devices (USB card reader, USB stick).

**UPnP AV** is used to control network devices from all manufacturers. Has become a widespread standard for home networking.

## V

**VGA:** PC interface for connecting a monitor.

**VPS:** The Video Programming System (VPS) is a signal which some (but not all) analogue TV stations transmit in the blanking interval. The signal is used by video and DVD recorders when recording programmes to react to delays in start time, programme changes and excesses of the planned programme time.

## W

**WEP:** Abbreviation for Wired Equivalent Privacy. Former standard process in the WiFi encryption, now outdated.

**Wired network:** see LAN.

**Wireless network:** see WLAN.

**WLAN:** Abbreviation for Wireless Local Area Network. Also abbreviated as wireless network.

**WMA:** Abbreviation for Windows Media Audio, Microsoft own audio data format. As with MP3 files, the content is compressed here as well.

**WMV:** Abbreviation for Windows Media Video, proprietary Microsoft video data format.

**WPA:** Abbreviation for Wi-Fi Protected Access. Replaced WEP as standard encryption for wireless networks.



**Y****Ycc/Ypp: Colour standards for Set-top boxes.**

**YCbCr:** Digital colour model, informally also incorrect designation for signals in standard resolution (**SDTV**). The YCbCr colour model, in which, e.g., DVDs are coded, has been developed from the YUV colour model used in analogue television technology. With YCbCr, the data is transferred via digital interfaces such as **DVI** or **HDMI** without being converted.

**YPbPr:** Analogue colour model, see also **Component connection**. The analogue YPbPr signal is generated from the YCbCr signal by a converter in the source player and then output at the 3 component outputs of the source player.

**YUV:** The YUV colour model is used for analogue television in accordance with the standards **PAL** and **NTSC**. YUV is often informally referred to when **YPbPr** (for analogue connections/cables) or **YCbCr** (in digital applications) is actually meant. YUV only occurs in quadrature modulation during PAL or NTSC transfer and is not otherwise used.

---

- BG** Този уред отговаря на основните изисквания и разширените съответни предпоставки **Директива 1999/5/ЕС**. Разрешено е използването му във всички държави от **ЕС**, и освен това в **Исландия, Норвегия и Швейцария**. Във **Франция и Италия** използването му е разрешено **само в затворени помещения**.
- CZ** Toto zařízení je v souladu se základními požadavky a ostatními odpovídajícími ustanoveními **Směrnice 1999/5/EG**. Může být používán ve všech zemích **EU** dodatečně také na **Islandu, v Norsku a ve Švýcarsku**. Ve **Francii** a v **Italii** je použití přístroje dovolené **jenom v interiéru**.
- D** Dieses Gerät entspricht den grundlegenden Anforderungen und den weiteren entsprechenden Vorgaben der Richtlinie **1999/5/EG**. Es darf in allen Ländern der **EU** sowie zusätzlich in **Island, Norwegen** und der **Schweiz** betrieben werden. In **Frankreich** und **Italien** ist die Nutzung **nur in Innenräumen** zulässig.
- DK** Dette udstyr er i overensstemmelse med de væsentlige krav og andre relevante bestemmelser i **Direktiv 1999/5/EF**. Det må kun anvendes i **EU-landene** samt i **Island, Norge** og **Schweiz**. I **Frankrig** og **Italien** er det kun tilladt at anvende det **inden-dørs**.
- E** Este equipo cumple con los requisitos esenciales así como con otras disposiciones de la **Directiva 1999/5/CE**. Puede operar en todos los países de la **UE** y adicionalmente en **Islandia, Noruega y Suiza**. En **Francia** e **Italia**, su uso está permitido **únicamente en espacios interiores**.
- FIN** Tämä laite täyttää **direktiivin 1999/5/EY** olennaiset vaatimukset ja on siinä asetettujen muiden laitetta koskevien määräysten mukainen. Laitetta saa käyttää kaikissa **EU-maissa** sekä **Islannissa, Norjassa** ja **Sveitsissä**. **Ranskassa** ja **Italiassa** laitetta saa käyttää **vain sisätiloissa**.
- F** Cet appareil est conforme aux exigences essentielles et aux autres dispositions pertinentes de la **Directive 1999/5/EC**. L'utilisation est possible dans tous les pays de l'**UE**, en **Islande**, en **Norvège** et en **Suisse**. En **France** et en **Italie** l'utilisation est autorisée **uniquement dans des espaces fermés**.
- GB** This equipment is in compliance with the essential requirements and other relevant provisions of **Directive 1999/5/EC**. It may be operated in all countries in the **EU** and also in **Iceland, Norway** and **Switzerland**. In **France** and **Italy** it may only be used **indoors**.
- GR** Αυτός ο εξοπλισμός είναι σε συμμόρφωση με τις ουσιώδεις απαιτήσεις και άλλες σχετικές διατάξεις της **Οδηγίας 1999/5/ΕΚ**. Επιτρέπεται η λειτουργία της σε όλες τις χώρες της **ΕΕ**, καθώς και στην **Ισλανδία**, στην **Νορβηγία** και στην **Ελβετία**. Στην **Γαλλία** και στην **Ιταλία** επιτρέπεται η χρήση **μόνο σε εσωτερικούς χώρους**.
- I** Questo apparato è conforme ai requisiti essenziali ed agli altri principi sanciti dalla **Direttiva 1999/5/CE**. Può essere messo in funzione in tutti i paesi dell'**UE** e inoltre in **Islanda, Norvegia** e in **Svizzera**. In **Francia** e in **Italia** è consentito l'uso **solo in ambienti chiusi**.
- N** Dette utstyret er i samsvar med de grunnleggende krav og andre relevante bestemmelser i **EU-direktiv 1999/5/EF**. Det kan brukes i alle **EU-land** og dessuten i **Island, Norge** og **Sveits**. I **Frankrike** og **Italia** er **kun innendørs bruk** tillatt.
- NL** Dit apparaat voldoet aan de essentiële eisen en andere van toepassing zijnde bepalingen van de **Richtlijn 1999/5/EG**. Het gebruik is toegestaan in alle landen van de **EU** en ook in **IJsland, Noorwegen** en **Zweden**. In **Frankrijk** en **Italië** is het gebruik **slechts binnenshuis** toegestaan.
- P** Este aparelho está em conformidade com os requisitos fundamentais e todas as restantes disposições da **Directiva 1999/5/CE**. Pode ser utilizado em todos os países da **UE** assim como na **Islândia, Noruega** e **Suíça**. Em **França** e **Itália** a sua utilização apenas é permitida em espaços interiores.
- S** Denna utrustning är i överensstämmelse med de väsentliga kraven och andra relevanta bestämmelser i **Direktiv 1999/5/EC**. Apparaten får användas i alla länder inom **EU** liksom på **Island**, i **Norge** och i **Schweiz**. I **Frankrike** och **Italien** får apparaten användas **endast inomhus**.

## EG-Konformitätserklärung EC Conformity Declaration

**Dokument-Nr./Monat . Jahr:** 52421/52422/52424/ 11-2012  
*Document No./Month . Year*

**Hersteller:** Loewe Opta GmbH  
*Manufacturer:*

**Handelsname:** LOEWE.  
*Trade mark:*

**Adresse:** Industriestrasse 11, 96317 Kronach, Germany  
*Address:*

**Produkt:** Farbfernsehgerät mit LCD Flachbildschirm  
*Product:* Colour Television Receiver with LCD Flat Panel Display

**Produktbezeichnung:** Reference ID 40 / 52421 ; Reference ID 46 / 52422 ; Reference ID 55 / 52424  
*Product designation:*

Das bezeichnete Produkt stimmt mit den Vorschriften folgender Europäischer Richtlinien überein:  
*The designated product conforms to the provisions of the following European directives:*

### 2006/95/EG

Richtlinie des Rates vom 12. Dezember 2006 zur Angleichung der Rechtsvorschriften der Mitgliedsstaaten betreffend elektrischer Betriebsmittel zur Verwendung innerhalb bestimmter Spannungsgrenzen - Niederspannungsrichtlinie.  
*Electrical equipment designed for use within certain voltages limits - LV-Directive.*

### 2004/108/EG

Richtlinie des Rates vom 15. Dezember 2004 zur Angleichung der Rechtsvorschriften der Mitgliedsstaaten über die elektromagnetische Verträglichkeit.  
*Electromagnetic compatibility*

### 1999/5/EG

Richtlinie des Rates vom 9. März 1999 über Funkanlagen und Telekommunikationsendeinrichtungen und die gegenseitige Anerkennung ihrer Konformität  
*Radio equipment and Telecommunications Terminal Equipment and the Mutual Recognition of their Conformity*

### 2009/125/EG

Richtlinie des Europäischen Parlaments und des Rates vom 21. Oktober 2009 zur Schaffung eines Rahmens für die Festlegung von Anforderungen an die umweltgerechte Gestaltung energieverbrauchsrelevanter Produkte  
*Establishing a framework for the setting of ecodesign requirements for energy-relating products*

Anbringung der CE-Kennzeichnung: 12  
*Affixing of the CE marking*



Die Übereinstimmung des bezeichneten Produkts mit den Vorschriften der Richtlinien wird nachgewiesen durch die vollständige Einhaltung folgender Normen:

*The conformity of the designated product with the provisions of Directives is proved by full compliance with the following standards:*

### Richtlinie / Directive 2006/95/EG

EN 60065 2002 + A1 2006, A11 2008, A2 2010, A12 2011

### Richtlinie / Directive 2004/108/EG

<input checked="" type="checkbox"/> EN 55013 2001 + A1 2003, A2 2006	<input checked="" type="checkbox"/> EN 55024 2010	
<input checked="" type="checkbox"/> EN 55020 2007 + A11 2011	<input checked="" type="checkbox"/> EN 61000-3-2 2006	+ A1 2009, A2 2009
<input checked="" type="checkbox"/> EN 55022 2010	<input checked="" type="checkbox"/> EN 61000-3-3 2008	

### Richtlinie / Directive 1999/5/EG

<input checked="" type="checkbox"/> EN 62311 2008	<input checked="" type="checkbox"/> EN 301489-17 V2.1.1
<input checked="" type="checkbox"/> EN 301489-1 V1.9.2	<input checked="" type="checkbox"/> EN 300328 V1.7.1
<input checked="" type="checkbox"/> EN 301893 V1.6.1	<input type="checkbox"/>

Aussteller: Loewe Opta GmbH  
*Issuer*

Ort, Datum: Kronach, den 20.11.2012  
*Place, Date*

Rechtsverbindliche Unterschrift:  
*Legally binding signature*

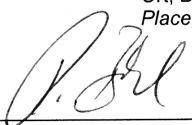
  
Name: ppä. Roland Bohl  
*Director R & D Product Development*

  
i. V. Reiner Nowitzki  
*Head of TV Device Development*

<b>0-9</b>		
24p format .....	126	
3D .....	86	
3D function .....	88	
3D mode .....	88	
<b>A</b>		
Access code .....	100	
Accurate Recording .....	80	
Adding stations to personal list .....	96	
Adjusting the sound .....	90	
Adjust size of the PIP image .....	99	
Allow switching voltage .....	123	
Antenna DVB .....	118, 123	
Antenna DVB-S .....	123	
Antenna DVB-T .....	123	
Archive recording .....	47	
Assign digital audio input .....	118, 125	
Audio commentary .....	105	
AUDIO key .....	133	
Audio playback .....	66	
Playback .....	66	
Auto dimming - Room .....	86, 88	
Auto dimming - Video (VBD+) .....	88	
Automatic scan TV+Radio .....	91, 92	
Automatic shutdown .....	7	
Auto speech detection .....	90	
AV connecting setting .....	123	
AV output signal .....	90	
AV selection .....	83	
AV standard .....	123	
<b>B</b>		
Balance .....	90	
Batteries .....	13	
Blu-ray player .....	126	
Bookmarks		
Delete .....	63	
Delete individual ones .....	63	
Jump .....	62	
Set .....	48, 61	
Brightness .....	86	
Browser .....	76	
Bundling the cables .....	13	
<b>C</b>		
Calling the Web browser .....	76	
Camcorder .....	126, 128	
CA modul .....	81, 109	
Changing the title of an archive .....	50	
Character table .....	17	
CI slot .....	81	
Cleaning and care .....	7	
Code number .....	100	
Coloured keys .....	41	
Colour intensity .....	86	
Colour temperature .....	86	
Common Interface .....	82	
Common Interface Plus .....	82	
Component connection .....	129	
Connecting active loudspeakers .....	131	
Connecting antennas .....	12	
Connecting HiFi/AV amplifier .....	131	
Connecting home network .....	13	
Connecting speaker system .....	130	
Connecting the TV set .....	12	
Connections .....	11, 85	
Contrast .....	86	
Control .....	85	
Copy recording to external hard disk .....	51	
Create new personal list .....	96	
<b>D</b>		
Data capture .....	105	
Deblocking filter .....	86	
Delete		
Bookmarks .....	63	
individual bookmarks .....	63	
Recording .....	50	
Delete manager .....	51	
Set delete protection for timer recording .....	80	
Setting/cancelling delete protection .....	51	
Delete personal list .....	96	
Deleting blocks .....	95	
Deleting stations from the personal list .....	96	
Digital camera .....	128	
Digital Link .....	124	
Digital Link HD functionality .....	124	
Digital Noise Control (DNC) .....	86	
Direct recording .....	47	
One Touch Recording .....	47	
DR+ archive .....	49	
DR+ Streaming .....	53, 84	
Extended standby mode .....	84	
Playback via the network .....	53	
DR+ Streaming settings .....	106	
Also use other archives .....	106	
DR+ device group name .....	106	
DR+ device name .....	106	
DR+ standby .....	106	
IP port number .....	106	
Share DR+ archive with other devices .....	106	
DVB character set .....	105	
DVB settings .....	105	
DVD player .....	126	
DVI .....	126	
<b>E</b>		
Edit new personal list .....	96	
Edit personal list .....	96	
Energy efficiency .....	20, 77	
Environment .....	148	
EPG .....	38	
Exit Browser .....	76	
External hard disk .....	51	
Extras .....	77	
<b>F</b>		
Favourites .....	33	
Film quality improvement (DMM) .....	86	
FLOF .....	41	
<b>G</b>		
Game console .....	124, 126	
Gaming mode .....	124	
General information on menu operation .....	15	

## H

Hard disks	113
Checking	113
Formatting	113
HbbTV	43
HbbTV text	43
HDMI	126
Headphone volume	37
Home networking systems	132
Home view	32

## I

Image+ Active	86
Info display	18
Initial installation wizard	20
Installing the TV set	12
Integrated features	83, 146
Internal WLAN antenna	54
Interval functions	61
Deleting part of the recording	62
Hide	62

## J

Jump	58, 67
Jump distance	106
Jump to bookmarks	62

## L

Language	20, 99, 139
LED light module	110
Length of the station list	34
LNC/LNB	25, 27, 28
Loewe Apps	136
Loudness	90

## M

Mains switch	10, 14
Manual scan Radio	91
Manual scan TV	91
Maximum volume	90
Media	
Access	54
Exit	54
Overview	54
MediaNet	74
Browse	75
Call	74
Exit	74
Settings	75
Mobile phone keyboard	17
Move block	95
Move picture up/down	86
Move stations in the personal list	96
Multimedia / Network	85
Multimedia settings	117
Music playback	
end	68
Radio mode	69
Repeat	68
Shuffle playback	68
Winding	67

## N

Network connections	
Wired	54
Wireless	54
Network selection	22, 23
Network settings	114
Notify hidden sections	106
Numerical keys	15, 34

## O

One Touch Recording	47
On/Off button	10
On-screen displays	104
OPC	86

## P

Page selection	41
Parental lock	52, 100
PC	128
PC IN - Display	86
Personal list	35
Add station	96
Create new list	96
Delete list	96
Delete station	96
Move station	96
Rename list	96
Photo	71
Exit	73
Full-screen mode	73
Rotating the photo	73
Slide show	73
Picture	85, 86
Picture adjustment	86, 87
Picture format	86, 87
4:3	87
16:9	87
PALplus	87
Panorama	87
Zoom	87
Picture settings	86
PIP	44
PIP Settings	99
Positioning/aligning the DVB-T antenna	123

## R

Record conflict	79
Recording	112
Post record time	112
Pre-record time	112
Remote control	9, 13, 133
Remote TV switch on via Digital Link	124
Renaming the personal list	96
Repeat initial installation	20, 83
Reset to factory settings	83
Network	83
Picture/Sound	83
Speaker system	83
Restore stations	95
Rotate TV	42, 111
RS-232C interface	132

**S**

Safety	6, 7
Satellite selection	25, 26, 27, 28
Satellite system	24
Scope of delivery	5
Scrambled stations	22, 23, 29, 81, 92
Selecting a station out of the station list	34
Select station	34
using the numerical keys	34
via favourites list	35
with P+/P-	34
Service	158
Set covers	12
Setting the HiFi/AV amplifier	122
Setting the volume	34
Set-top box	126
Sharpness	86
Side by side	88
Signal type	123
Skin tone	86
Slow motion	60
Smart Card	81
Smart jump	58
Smart Jump	106
Software download	101
Software update	
Manually via Internet	103
Via USB memory medium	102
Sound	85, 90
Sound adjustment	90
Sound components	119
Special functions	83
Standby mode	14
Station lists Radio	91, 95
Station lists TV	91, 95
Stations	85, 91
Status display	36
STB key	133
Stop recording early	48
Subtitle	48, 63, 105, 106
Supply voltage 5V	123
Switching off the TV set during recording	48
Switch off	14
Switch on	14
Switch-on volume	90
Switch to live picture	46
System settings	85

**T**

Teletext	41
Time and date	104
Timer	77
Timer Instructions	77
Timer data	80
Automatic time control	80
Beginning	80
Date	80
Delete protection	80
End	80
Favourite	80
Lock recording	80
Recording subtitles	80
Recording type	80
Station	80
Top/bottom	88
TV	34
TV key	13, 133
TV on when memorised	105
TV viewing with time shift	46, 48

**U**

UPnP	54
USB stick	101

**V**

VBD+	86
VIDEO key	133
Video playback	56
Change picture format	60
Jump by entering a time	58
Playback	56
Repeat	59
Selecting language/sound	60
Winding	59
Viewing a locked movie	52
Viewing another movie from the archive during archive recording	48

**W**

Watching other stations during archive recording	48
Web	74

**Y**

YPbPr	129
YUV	129

**(A)** Loewe Austria GmbH  
Parkring 12  
1010 Wien, Österreich  
Tel +43 - 810 0810 24  
Fax +43 - 1 22 88 633 - 90  
E-mail: loewe@loewe.co.at

**(AUS)**  
Audio Products Group Pty Ltd  
67 O'Riordan St  
Alexandria NSW 2015, Australia  
Tel +61 - 1300 130 492  
Fax +61 - 02 9578 0140  
E-mail: help@audioproducts.com.au

**(B NL L)**  
Loewe Opta Benelux NV/SA  
Uilenbaan 84  
2160 Wommelgem, België  
Tel +32 - 3 - 2 70 99 30  
Fax +32 - 3 - 2 71 01 08  
E-mail: ccc@loewe.be

**(BG)** Darlington Service  
193 Kn. Klementina St.  
1612 Sofia, Bulgaria  
Tel +359 - 2 9556399  
E-mail: darlington@psp-bg.com

**(CH)** Telion AG  
Rütistrasse 26  
8952 Schlieren, Schweiz  
Tel +41 - 44 732 15 11  
Fax +41 - 44 732 15 02  
E-mail: infoKD@telion.ch

**(CY)** Hadjikyriakos & Sons Ltd.  
121 Prodromos Str., P.O Box 21587  
1511 Nicosia, Cyprus  
Tel +357 - 22 87 21 11  
Fax +357 - 22 66 33 91  
E-mail: savvas@hadjikyriakos.com.cy

**(CZ)** BaSys CS s.r.o.  
Sodomkova 1478/8  
10200 Praha 10 - Hostivar,  
**Česká republika**  
Tel +420 234 706 700  
Fax +420 234 706 701  
E-mail: office@basys.cz

**(D)** Loewe Opta GmbH,  
Customer Care Center  
Industriestraße 11  
96317 Kronach, Deutschland  
Tel +49 9261 99-500  
Fax +49 9261 99-515  
E-mail: ccc@loewe.de

**(DK)** Kjaerulff1 Development A/S  
C.F. Tietgens Boulevard 19  
5220 Odense SØ, Denmark  
Tel +45 - 66 13 54 80  
Fax +45 - 66 13 54 10  
E-mail: info@loewe.dk

**(E)** Gaplasa S.A.  
Conde de Torroja, 25  
28022 Madrid, España  
Tel +34 - 917 48 29 60  
Fax +34 - 913 29 16 75  
E-mail: loewe@maygap.com

**(F)** Loewe France SAS  
Rue du Dépôt,  
13 Parc de l'Europe, BP 10010  
67014 Strasbourg Cédex, France  
Tel +33 - 3 - 88 79 72 50  
Fax +33 - 3 - 88 79 72 59  
E-mail: loewe.france@loewe-fr.com

**(FIN)** Karevox Oy  
Museokatu 36  
00100 Helsinki, Finland  
Tel +358 - 9 44 56 33  
E-mail: kare@haloradio.fi

**(GB IRL)** Loewe UK Limited  
1st Floor, 237A Kensington High St  
London  
W8 6SA, UK  
Tel +44 - (0) 207 368 1100  
Fax +44 - (0) 207 368 1101  
E-mail: enquiries@loewe-uk.com

**(GR RO)** Issagogiki Emboriki Ellados  
S.A.  
321 Mesogion Av.  
152 31 Chalandri-Athens, Hellas  
Tel +30 - 210 672 12 00  
Fax +30 - 210 674 02 04  
E-mail: christina\_argyropoulou@  
isembel.gr

**(H)** Basys Magyarorszag KFT  
Tó park u.9.  
2045 Törökbálint, Magyar  
Tel +36 - 2341 56 37 (121)  
Fax +36 - 23 41 51 82  
E-mail: ertekesites@basys.hu

**(HK CN)** Galerien Und Partner Plus  
King's Tower 28/F, 111 King Lam Street  
Kowloon, Hong Kong  
Tel +852 - 27 77 89 88  
Fax +852 - 23 10 08 08  
E-mail: service@loewe-cn.com

**(HR)** Plug&Play Ltd.  
Bednjanska 8, 10000 Zagreb  
Hrvatska (Kroatia)  
Tel +385 1 4929 683  
Fax +385 1 4929 682  
E-mail: info@loewe.hr

**(I)** Loewe Italiana S.r.L.  
Via Monte Baldo, 14/P - 14/N  
37069 Dossobuono di Villafranca di  
Verona  
Tel +39 - 045 82 51 690  
Fax +39 - 045 82 51 622  
E-mail: info@loewe.it

**(IL)**  
Clear electronic entertainment Ltd  
13 Noah Mozes St.  
Agish Ravad Building  
Tel Aviv 67442, Israel  
Tel +972 - 3 - 6091100  
Fax +972 - 3 - 6092200  
E-mail: info@loewe.co.il

**(IND)** Navshiv Retail Pvt. Ltd.  
Block D, Plot No. 7 Shanti Kunj  
Vasant Kunj  
New Delhi - 110070, India  
Tel +91 11 47 65 55 00  
Fax +91 11 47 67 67 15  
E-Mail: admin@navshiv.com

**(IR)** MiMoRa HOLDING CO.  
N0 1001, Afra Tower  
Parsa St. Fereshteh  
Tehran, Iran  
Tel + 98 921 344 0521  
E-Mail: s.zarandooz@gmail.com

**(KSA)** Salem Agencies & Services Co.  
Hamad Al Haqueel Street, Rawdah,  
Jeddah 21413  
Kingdom of Saudi Arabia  
Tel +966 (2) 665 4616  
Fax +966 (2) 660 7864  
E-mail: hkurkjian@aol.com

**(LV EST)** Kpartners, SIA  
**A.Čaka iela 80**  
**Rīga, LV-1011, Latvia**  
Tel +3 71 - 67 29 29 59  
Fax +3 71 - 67 31 05 68  
E-mail: olga@dom332.lv

**(LT)** A Cappella Ltd.  
Ausros Vartu 5, Pasazo skg.  
01129 Vilnius, Lithuania  
Tel +370 - 52 12 22 96  
Fax +370 - 52 62 66 81  
E-mail: info@loewe.lt

**(M)** Doneo Co. Ltd  
34/36 Danny Cremona Street  
Hamrun, HMR1514, Malta  
Tel +356 - 21 - 22 53 81  
Fax +356 - 21 - 23 07 35  
E-mail: service@doneo.com.mt

**(MA)** Somara S.A.  
377, Rue Mustapha El Maani  
20000 Casablanca, Morocco  
Tel +212 - 22 22 03 08  
Fax +212 - 22 26 00 06  
E-mail: somara@somara.ma

**(N)** Premium Consumer Electronics as  
Østre Kullerød 5  
3241 Sandefjord, Norge  
Tel +47 - 33 29 30 40  
Fax +47 - 33 44 60 44  
E-mail: loewe@loewe.no

**(NZ)** Audio Products Group Pty Ltd  
67 O'Riordan St  
Alexandria NSW 2015, Australia  
Tel 0800 174 781  
Fax +61 - 02 9578 0140  
E-mail: help@audioproducts.com.au

**(P)** Mayro Magnetics Portugal, Lda.  
Rua Professor Henrique de Barros  
Edifício Sagres, 2º. C  
2685-338 Prior Velho, Portugal  
Tel +351 - 21 942 78 30  
Fax +351 - 21 940 00 78  
E-mail: geral.loewe@mayro.pt

**(PL)** Tele Radio Video  
Ul. Boh. Getta Warszawskiego 18  
81-609 Gdynia  
Tel. 58 624-50-09  
E-Mail: loewe@trv.com.pl

**(RUS)** Service Center Loewe  
Aptekarsky per.4 podjezd 5A  
105005 Moscow, Russia  
Tel +7 - 499 940 42 32 ( ext. 454 )  
Fax +7 - 495 730 78 01  
E-mail: service@loewe-cis.ru

**(S)** Kjaerulff 1 AB  
Ridbanegatan 4, Box 9076  
200 39 Malmö, Sverige  
Tel +46 - 4 06 79 74 00  
Fax +46 - 4 06 79 74 01  
E-mail: loewe@loewe.se

**(SG)** Atlas Sound & Vision Pte Ltd  
10 Winstedt Road #01-18  
Singapore 227977  
Tel +65 - 6334 9320  
Fax +65 - 6339 1615  
E-mail: service@atlas-sv.com

**(SK)** BaSys SK, s.r.o.  
Stará Vajnorská 37/C  
83104 Bratislava, Slovakia  
Tel + 421 2 49 10 66 18  
Fax + 421 2 49 10 66 33  
E-mail: loewe@basys.sk

**(TR)** SERVISPLUS GENEL MERKEZ  
ÖRNEK MAH. ATES SOK. NO:1  
34704 ATASEHIR, ISTANBUL, TÜRKİYE  
Tel +90 - 216 315 39 00  
Fax +90 - 216 315 49 50  
E-mail: info@servisplus.com.tr

**(UAE)** Dubai Audio Center  
P.O. Box 32836, Sheikh Zayed Road  
Dubai, UAE  
Tel +971 - 4 343 14 41  
Fax +971 - 4 343 77 48  
E-mail: service@dubaiaudio.com





OPTIMA	133	SATMASTER	013	THORENS	191, 205, 206, 211
OPTUS	332	SATPARTNER	017, 079, 094, 133, 179,	THORN	225
ORBIT	025, 194		180, 193, 201	THORN-FERGUSON	023, 048, 067
ORBITECH	006, 017, 103, 169, 181, 224	SATSTATION	151	TIOKO	135, 175
ORIGO	126, 221	SAVA	077, 108, 161, 164, 171,	TLEWIRE	059
OSAT	097		172, 179, 200, 201, 206, 217	TOKAI	033
OTTO VERSAND	090	SCHACKE	180	TONNA	060, 006, 013,
OXFORD	104	SCHAUB LORENZ	088, 099		059, 067, 171, 210
<b>P</b>		SCHNEIDER	171, 172, 218	TOPFIELD	011
PACE	001, 022, 044, 048, 050,	SCHWAIGER	077, 114, 135, 161, 164,	TORX	341
	067, 077, 098, 108, 124,		169, 197, 217, 255	TOSHIBA	067, 145
	189, 202, 227, 242, 252,	SCIENTIFIC ATLANTA	305, 306, 325, 326	TPS	129, 205
	253, 319, 347	SEDEA-ELECTRONIQUE	017	TRENDLINE	222
	225	SEEMANN	047, 104, 175, 223	TRENDPLAIN	222
PACIFIC		SEG	017, 094, 165,	TRGRA	088
PACKSAT	171, 172		178, 190, 197, 226	TRIAD	085, 101, 127, 193, 194
PALCOM	092	SELECO	059, 213	TRIASAT	006, 220
PALLADIUM	003, 006, 017, 175	SEPTIMO	146, 151, 154	TRIAx	060, 006, 033,
PALSAT	006	SERVI SAT	059		047, 211, 220, 230
PANASAT	235, 254	SIEMENS	090, 176, 199	TRISTAR	025
PANASONIC	031, 067, 124, 227	SILVA	079, 193	TUDI	327
PANDA	021, 048, 067, 164, 176, 210	SINTRACK	013	TWINNER	115, 119
PATRIOT	104	SKANTIN	060	<b>UNIDEN</b>	058, 071, 080, 148, 208
PHILIPS	026, 003, 033, 037, 051,	SKARDIN	223	UNISAT	033, 054, 175
	067, 077, 124, 128, 144,	SKINSAT	006	UNITED CABLE	330, 341
	156, 161, 162, 169, 171,	SKR	060	UNITOR	051, 094
	172, 176, 180, 187, 188,	SKY	034, 050, 189, 227, 001	UNIVERSUM	003, 009, 071,
	191, 204, 211, 218, 229,	SKY MASTER	060, 133, 168,		164, 165, 176
	242, 313, 323, 329, 345		170, 197, 215	<b>VAIADIGITAL</b>	078
PHOENIX	054, 077	SKY PLUS	002	VARIOSAT	176
PHONOTREND	042, 059, 133,	SKYLAB	051	VARIOSAT	176
	142, 168, 212	SKYMAX	033	VECTOR	178
PIONEER	128, 191, 211, 302	SKYSAT	197	VENTANA	033, 037
PIXX	255	SKYVISION	059	VESTEL	165
PLANET	126, 213	SL	161, 165, 175, 186	VIASAT	016
POLSAT	110	SM ELECTRONIC	060	VIDEOCRYPT	023
POLYTRON	047, 135	SMART	186	VIDEOTRON	331
PREDKI	017, 094	SONY	067, 211, 227	VIDEOWAY	331
PREISNER	047, 103, 163, 169,	SR	222	VIDIO WAY	015
	175, 186, 199, 222	STARLAND	060	VIPER	054
PREMIER	059, 133	STARRING	094	VIRGIN MEDIA	063
PREMIERE	191, 211, 214, 007	STARSAT	080	VISIOPASS	309, 313, 329
PROMAX	067	STRONG	017, 025, 179, 180, 186,	VISIOSAT	060, 194, 200
PROSAT	168, 170		196, 211, 226, 235	VIVA	161, 162
PROSONIC	165	STS	328	VORTEC	017, 082, 083, 132, 142
PROTEK	225	STV	014	VTECH	127, 194, 200, 204
PROVISAT	201	STVI	014, 137	<b>WELA</b>	060, 163, 169, 186
PROVISION	179	SUMIDA	175	WESTMINSTER	335
PVP STEREO VISUAL	330	SUNNY SOUND	226	WETEKOM	006, 197, 207
PVP STEREO VISUAL MATRIX	341	SUNSAT	060, 223	WEWA	067
PYE	003	SUNSTAR	163, 175, 186, 222, 226	WIBO	175
PYXIS	208, 210	SUPERCABLE	343	WINERSAT	094
<b>Q</b>		SUPERNOVA	189	WINTERGARTEN	168
QUADRAL	168, 169, 170,	<b>T</b>	059	WISI	006, 047, 067, 088,
	171, 172, 173, 226	TAGRA	008		123, 127, 164, 169,
QUELLE	090, 097, 164, 165	TANDBERG	085, 122		176, 194, 200, 210
QUIERO	110	TANTEC	067, 108	WITTENBERG	071
<b>R</b>		TATUNG	067	WOLSEY	085, 122
RADIOLA	033, 037	TCM	116	WOORISAT	179
RADIX	047, 137, 216	TECHNILAND	013, 059	WORLD	094
RAINBOW	137, 180	TECHNISAT	006, 028, 033, 047, 102	WORLDSAT	171, 172
RC	138		103, 181, 184, 224, 231	<b>X</b>	169
RC-1000	104	TECHNOWELT	164	COM	046
RED STAR	226	TECO	025, 175, 222	XCOM MULTIMEDIA	226
REDPOINT	223	TELASAT	164, 197	XRYPTON	060, 046, 166, 169
REDSTAR	226	TELECIEL	180, 201	<b>Y</b>	189
RFT	033, 037, 161, 162, 168, 224	TELECOM	060	<b>Z</b>	161
ROADSTAR	060	TELEDIREKT	077	AUNKONIG	
ROVER	060, 170	TELEFUNKEN	017, 083, 171, 172	ZEHNDER	051, 080, 114, 127, 135
<b>S</b>		TELEKA	026, 006, 047, 081, 103,		165, 179, 204, 226, 255
SABA	077, 108, 161, 164,		180, 161, 164, 175, 203, 210	ZENITH	034, 314
	171, 172, 179, 200,	TELEMASTER	179	ZETA-TECHNOLOGY	033
	201, 206, 217, 229	TELEMAX	018	ZODIAC	180
SABRE	067	TELEPIU	320, 321	ZWERNASE	163, 175
SAGEM	205, 329	TELE PLUS ONE	320, 321		
SAKURA	054, 057	TELESAT	164, 197		
SALORA	021, 088, 099, 120, 130, 303	TELESERVICE	311, 314		
SAMSUNG	017, 080, 127, 132,	TELESTAR	006		
	211, 243, 302, 324	TELETECH	215		
SAT	006, 071, 127, 194	TELEVES	006, 067		
SAT PARTNER	017, 094, 133,	TELEWIRE	059		
	179, 180, 193, 201	TENSAI	025, 094		
SAT TEAM	060	TEVION	116		
SATBOX	304	THOMSON	060, 049, 067, 128,		
SATCOM	013, 164, 197		155, 164, 171, 172,		
SATEC	060, 077, 242				
SATECO	017				
SATELCO	226				
SATFORD	013				
SATLINE	170				







---

---

**LOEWE.**