

# PENTAX

ENG

Digital Camera

# Optio S1

## Operating Manual

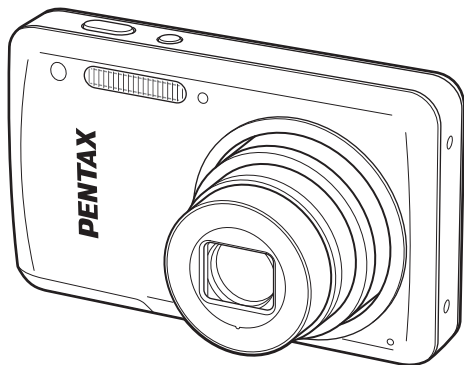

To ensure the best performance from your camera, please read the Operating Manual before using the camera.

Thank you for purchasing this PENTAX Digital Camera. Please read this manual before using the camera in order to get the most out of all the features and functions. Keep this manual safe, as it can be a valuable tool in helping you to understand all the camera's capabilities.

### **Regarding copyrights**

Images taken with the PENTAX Digital Camera that are for anything other than personal enjoyment cannot be used without permission according to the rights as specified in the Copyright Act. Please take care, as there are cases where limitations are placed on taking pictures even for personal enjoyment during demonstrations, performances or of items on display. Images taken with the purpose of obtaining copyrights also cannot be used outside the scope of use of the copyright as laid out in the Copyright Act, and care should be taken here also.

### **Regarding trademarks**

- PENTAX and Optio are trademarks of HOYA CORPORATION.
- SDXC Logo is a trademark of SD-3C, LLC.
- ArcSoft, and its logo are either the registered trademark or trademark of ArcSoft Inc. in the United States and/or other countries.
- Microsoft and Windows are registered trademarks of Microsoft Corporation in the United States and other countries. Windows Vista is either a registered trademark or trademark of Microsoft Corporation in the United States and/or other countries.
- Macintosh and Mac OS are trademarks of Apple Inc., registered in the U.S. and other countries.
- All other brands or product names are trademarks or registered trademarks of their respective companies. In this manual, the ™ and ® marks are not specified.
- This product supports PRINT Image Matching III. PRINT Image Matching enabled digital still cameras, printers and software help photographers to produce images more faithful to their intentions. Some functions are not available on printers that are not PRINT Image Matching III compliant. Copyright 2001 Seiko Epson Corporation. All Rights Reserved. PRINT Image Matching is a trademark of Seiko Epson Corporation. The PRINT Image Matching logo is a trademark of Seiko Epson Corporation.

### **Regarding Product Registration**

In order to better serve you, we request that you complete the product registration, which can be found on the CD-ROM supplied with the camera or the PENTAX website. Thank you for your cooperation.

Refer to "Connecting to a Computer" (p.181) for more information.

## To users of this camera

- Do not use or store this device in the vicinity of equipment that generates strong electromagnetic radiation or magnetic fields.  
Strong static charges or the magnetic fields produced by equipment such as radio transmitters could interfere with the monitor, damage the stored data, or affect the product's internal circuitry and cause camera misoperation.
- The liquid crystal panel used for the display is manufactured using extremely high precision technology. Although the level of functioning pixels is 99.99% or better, you should be aware that 0.01% or fewer of the pixels may not illuminate or may illuminate when they should not. However, this has no effect on the recorded image.
- If you point the camera toward an object that is bright, a band of light may appear on the screen display. This phenomenon is referred to as "smear" and is not a malfunction of the camera.
- There is a possibility that the illustrations and the screen display in this manual are different from the actual ones.
- In this manual, SD Memory Cards, SDHC Memory Cards, and SDXC Memory Cards are referred to as SD Memory Cards hereafter.
- In this manual, the generic term "computer(s)" refers to either a Windows PC or a Macintosh hereafter.
- In this manual, the term "battery(ies)" refers to any type of batteries used for this camera and its accessories.

## Using Your Camera Safely

We have paid close attention to the safety of this product. When using this product, we request your special attention regarding items marked with the following symbols.



### Warning

This symbol indicates that violating this item could cause serious personal injuries.



### Caution

This symbol indicates that violating this item could cause minor or medium personal injuries, or loss of property.

## About the Camera

### **Warning**

- Do not disassemble or modify the camera. High voltage areas are present inside the camera, with the risk of electric shock.
- If the camera interior is exposed due to dropping or otherwise damaging the camera, never touch the exposed portion. There is a risk of electric shock.
- Wrapping the strap around your neck is dangerous. Take care that small children do not hang the strap around their necks.
- If any irregularities occur during use, such as smoke or a strange odor, stop use immediately, remove the battery, and contact your nearest PENTAX Service Center. Continuing to use the camera can cause a fire or electric shock.

### **Caution**

- Do not place your finger over the flash when discharging the flash. You may burn yourself.
- Do not cover the flash with clothes when discharging the flash. Discoloration may occur.
- Some portions of the camera heat up during use. There is a risk of low temperature burns when holding such portions for long periods.
- Should the monitor be damaged, be careful of glass fragments. Also, be careful not to allow the liquid crystal to get on your skin, in your eyes or mouth.
- Depending on your individual factors or physical condition, the use of the camera may cause itching, rashes or blisters. In case of any abnormality, stop using the camera and get medical attention immediately.

## About the Power Adapter

### **Warning**

- Always use the power adapter exclusively developed for this camera, with the specified power and voltage. Using a power adapter not exclusive to this camera, or using the exclusive power adapter with an unspecified power or voltage can cause a fire, electric shock, or camera breakdown. The specified voltage is 100 - 240V AC.

- Do not disassemble or modify the power adapter. This can cause a fire or electric shock.
- If the generation of smoke or strange odor from the power adapter or other abnormality occurs, immediately discontinue use and consult a PENTAX Service Center. Continuing to use the adapter can cause a fire or electric shock.
- If water should happen to get inside the power adapter, consult a PENTAX Service Center. Continuing to use the adapter can cause a fire or electric shock.
- If a thunder storm should occur while using the power adapter, unplug the adapter and discontinue use. Continuing to use the adapter can cause damage to the equipment, fire, or electric shock.
- Wipe off the plug of the power adapter if it becomes covered with dust. Accumulated dust on the plug may cause a fire.



### **Caution**

- Do not place or drop heavy objects on the power adapter. Doing so may damage the adapter. Should the power adapter be damaged, consult a PENTAX Service Center.
- Do not touch or short-circuit the terminal area of the power adapter while the cord is plugged in.
- Do not handle the power adapter with wet hands. This can cause an electric shock.
- Do not drop the power adapter, or subject it to violent impact. This can cause equipment breakdown.
- Do not use the power adapter to charge a battery other than a rechargeable lithium-ion battery D-LI78. This can cause an explosion, or heating, or may damage the power adapter.

## About the Battery

### **Warning**

- Be sure to store the battery out of the reach of small children. Placing it in their mouths may cause an electric shock.
- If any leakage from the battery should come in contact with your eyes, do not rub them. Flush your eyes with clean water and get medical attention immediately.

### **Caution**

- Only use the specified battery with this camera. Use of other batteries may cause an explosion or fire.
- Do not disassemble the battery. Disassembling the battery may cause an explosion or leakage.
- Remove the battery from the camera immediately if it becomes hot or begins to smoke. Be careful not to burn yourself during removal.
- Keep wires, hairpins, and other metal objects away from the + and - contacts of the battery.
- Do not short the battery or dispose of the battery in fire. This can cause an explosion or fire.
- If any leakage from the battery should come in contact with skin or clothes, wash the affected areas thoroughly with water.
- Precautions for D-LI78 Battery Usage:
  - USE SPECIFIED CHARGER ONLY.
  - DO NOT INCINERATE.
  - DO NOT DISASSEMBLE.
  - DO NOT SHORT CIRCUIT.
  - DO NOT EXPOSE TO HIGH TEMP. (140°F / 60°C)

## Keep the Camera and its Accessories out of the Reach of Small Children

### **Warning**

- Do not place the camera and its accessories within the reach of small children.
  1. If the product falls or is operated accidentally it may cause serious personal injuries.
  2. Wrapping the strap around a neck may cause suffocation.

3. To avoid the risk of a small accessory such as the battery or SD Memory Cards from being swallowed by mistake, keep them out of the reach of small children. Seek medical attention immediately if an accessory is accidentally swallowed.

## Care to be Taken During Handling

### Before Using Your Camera

- When traveling, take the Worldwide Service Network listing that is included in the package. This will be useful if you experience problems abroad.
- When the camera has not been used for a long time, make sure that it is still working properly, particularly prior to taking important pictures (such as at a wedding or when traveling). Contents of the recording cannot be guaranteed if recording, playback or transferring your data to a computer, etc. is not possible due to a malfunction of your camera or recording media (SD Memory Card), etc.

### About the Battery

- Storing the battery fully charged may decrease the battery performance. Avoid storing in high temperatures.
- If the battery is left inserted and the camera is not used for a long time, the battery will over-discharge and shorten the battery's life.
- Charging the battery a day before use or on the day of use is recommended.

### Precautions on Carrying and Using Your Camera

- Do not subject the camera to high temperatures or high humidity. Do not leave the camera in a vehicle, as the temperature can get very high.
- Do not subject the camera to strong vibrations, shocks, or pressure. Use a cushion to protect the camera from vibrations of motorcycles, automobiles, or ships.
- The temperature range for camera use is 0°C to 40°C (32°F to 104°F).
- The monitor may appear black at high temperatures, but will return to normal at normal temperatures.
- The monitor may respond more slowly at low temperatures. This is due to liquid crystal properties, and is not a malfunction.

- Sudden temperature changes will cause condensation on the inside and outside of the camera. Place the camera in your bag or a plastic bag, and remove it after the temperature of the camera and surroundings are equalized.
- Avoid contact with garbage, mud, sand, dust, water, toxic gases, or salt. These could cause the camera to breakdown. Wipe the camera to dry off any rain or water drops.
- Please do not press forcefully on the monitor. This could cause it to break or malfunction.
- Be careful not to sit down with the camera in your back pocket as this may damage the exterior of the camera or the display.
- Be careful not to overtighten the tripod screw when using a tripod.
- The lens on this camera is not interchangeable. The lens is not removable.

### **Cleaning Your Camera**

- Do not clean the camera with organic solvents such as thinner, alcohol or benzene.
- Use a lens brush to remove dust accumulated on the lens. Never use a spray blower for cleaning as it may damage the lens.

### **Storing Your Camera**

- Do not store the camera with preservatives or chemicals. Storage in high temperatures and high humidity can cause mold to grow on the camera. Remove the camera from its case and store it in a dry and well-ventilated location.

### **Other Precautions**

- Periodic inspections are recommended every one to two years to maintain high performance.
- Refer to “Precautions When Using an SD Memory Card” (p.38) regarding the SD Memory Card.
- Please note that deleting images or sound files, or formatting the SD Memory Cards or the built-in memory does not completely erase the original data. Deleted files can sometimes be recovered using commercially available software. It is user’s responsibility to ensure the privacy of such data.



# Contents

Using Your Camera Safely .....	1
Care to be Taken During Handling .....	5
Contents .....	7
Composition of the Operating Manual .....	13
<b>Camera Features .....</b>	<b>14</b>
Checking the Contents of the Package .....	17
Names of Parts .....	18
Names of Operating Parts .....	19
Monitor Indications .....	20
<b>Getting Started .....</b>	<b>29</b>
<b>Attaching the Strap .....</b>	<b>30</b>
<b>Powering the Camera .....</b>	<b>31</b>
Installing the Battery .....	31
Charging the Battery .....	33
<b>Installing an SD Memory Card .....</b>	<b>36</b>
Number of Recordable Images .....	39
<b>Turning the Camera On and Off .....</b>	<b>40</b>
Starting-up in the Playback Mode .....	41
<b>Initial Settings .....</b>	<b>42</b>
Setting the Display Language .....	42
Setting the Date and Time .....	46
<b>Common Operations .....</b>	<b>49</b>
<b>Understanding the Button Functions .....</b>	<b>50</b>
📷 Mode .....	50
▶ Mode .....	52
Switching Between 📷 Mode and ▶ Mode .....	54
<b>Setting the Camera Functions .....</b>	<b>55</b>
Operating the Menus .....	55
Menu List .....	58

<b>Taking Still Pictures</b> .....	<b>64</b>
Taking Pictures .....	64
Setting the Shooting Mode .....	67
Using the Face Detection Function .....	69
Taking Pictures Automatically (Auto Picture Mode) .....	70
Taking Pictures in the Custom Settings (Program Mode) .....	71
Taking Pictures in the Basic Mode (Green Mode).....	72
Using the Zoom .....	73
Taking Pictures of Dark Scenes (Night Scene/Night Scene Portrait/ Digital SR/Fireworks/Candlelight Mode) .....	75
Taking Pictures of People (Portrait/Natural Skin Tone Mode).....	76
Taking Pictures of Children (Kids Mode) .....	77
Taking Pictures of Your Pet (Pet Mode).....	78
Taking Pictures of Sports and Leisure Activities (Sport/Surf & Snow Mode) .....	79
Framing Your Pictures (Frame Composite Mode).....	80
Taking Pictures Indoors (Party Mode) .....	81
Taking Pictures of Text (Text Mode) .....	82
Taking Pictures Using the Miniature/HDR Filter .....	83
Using the Camera's Self-timer.....	84
Taking a Series of Pictures (Continuous Shooting/Burst Shooting Mode).....	85
Taking Pictures Using the Remote Control Unit (Optional) .....	86
<b>Setting the Shooting Functions</b> .....	<b>88</b>
Selecting the Flash Mode .....	88
Selecting the Focus Mode .....	89
Selecting the Number of Recorded Pixels.....	92
Compensating for Exposure (EV Compensation).....	94
Correcting the Brightness (D-Range Setting).....	95
Adjusting the White Balance.....	96
Setting the AE Metering.....	98
Setting the Sensitivity .....	99
Switching the Face Detection Function .....	100
Setting the Shake Reduction Function .....	102
Setting the Instant Review.....	103
Setting the Image Sharpness (Sharpness).....	104
Setting the Color Saturation (Saturation).....	105
Setting the Image Contrast (Contrast).....	105
Setting the Date Imprint Function .....	106
Calling Up a Specific Function.....	107

<b>Recording Movies</b> .....	<b>109</b>
Recording a Movie .....	109
Selecting the Recorded Pixels and Frame Rate for Movies .....	111
Setting the Movie SR (Movie Shake Reduction) Function .....	112
<b>Saving the Settings (Memory)</b> .....	<b>113</b>
<b>Playing Back and Deleting Images</b> .....	<b>115</b>
<hr/>	
<b>Playing Back Images</b> .....	<b>116</b>
Playing Back Still Pictures .....	116
Playing Back a Movie .....	117
Multi-Image Display .....	118
Using the Playback Functions .....	120
Slideshow .....	121
Rotating an Image .....	124
Zoom Playback .....	125
<b>Deleting Images and Sound Files</b> .....	<b>126</b>
Deleting a Single Image .....	126
Deleting Selected Images and Sound Files.....	127
Deleting All Images and Sound Files.....	128
Protecting Images and Sound Files from Deletion (Protect) .....	129
<b>Connecting the Camera to AV Equipment</b> .....	<b>132</b>
<b>Editing and Printing Images</b> .....	<b>135</b>
<hr/>	
<b>Editing Images</b> .....	<b>136</b>
Changing the Image Size (Resize) .....	136
Cropping Images .....	137
Processing Images with the Miniature/HDR Filter .....	138
Processing Images with the Digital Filters .....	140
Compensating for an Unwanted Red-eye Effect .....	144
Adding a Frame (Frame Composite) .....	145
Editing Movies .....	148
Copying Images and Sound Files.....	150
<b>Setting the Printing Service (DPOF)</b> .....	<b>153</b>
Printing a Single Image .....	153
Printing All Images.....	155

---

<b>Recording Sound (Voice Recording)</b> .....	<b>158</b>
Setting the Voice Recording Function .....	158
Recording Sound .....	159
Playing Back Sound .....	159
<b>Adding a Voice Memo to Images</b> .....	<b>161</b>
Recording a Voice Memo .....	161
Playing Back a Voice Memo .....	162

**Settings**

---

<b>Camera Settings</b> .....	<b>164</b>
Formatting an SD Memory Card .....	164
Changing the Sound Settings .....	165
Changing the Date and Time .....	166
Setting the World Time .....	168
Changing the Display Language .....	171
Changing the Naming System of the Folder .....	172
Changing the Video Output Format .....	173
Adjusting the Brightness of the Display .....	174
Using the Power Saving Function .....	175
Setting the Auto Power Off Function .....	176
Changing the Start-up Screen .....	177
Correcting Defective Pixels in the CCD Sensor (Pixel Mapping) .....	178
Resetting to Default Settings (Reset) .....	179

**Connecting to a Computer**

---

<b>Connecting to a Computer</b> .....	<b>182</b>
Setting the USB Connection Mode .....	182
Connecting the Camera and the Computer .....	184
Disconnecting the Camera from the Computer .....	185
<b>Using the Provided Software</b> .....	<b>186</b>
System Requirements .....	186
Installing the Software .....	187
Using MediaImpression on Windows .....	190
Using MediaImpression on Macintosh .....	192



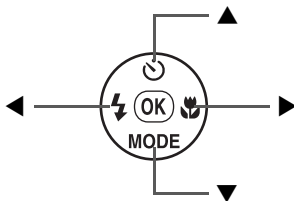

---

Functions Available for Each Shooting Mode.....	196
Messages.....	198
Troubleshooting.....	200
Default Settings.....	202
List of World Time Cities.....	207
Optional Accessories.....	208
Main Specifications.....	209
WARRANTY POLICY.....	213
Index.....	219

In this manual, the method for operating the four-way controller is shown in illustrations, such as in the ones below.



The meanings of the symbols used in this Operating Manual are explained below.

	indicates the reference page number for an explanation of the related operation.
	indicates information that is useful to know.
	indicates precautions to be taken when operating the camera.
 mode	This is the mode for capturing still pictures and recording movies.
 mode	This is the mode for viewing still pictures and playing back movies and sound files.

# Composition of the Operating Manual

This Operating Manual contains the following chapters.

## 1 Getting Started

This chapter explains what you need to do after purchasing the camera before you start taking pictures. Be sure to read this chapter and follow the instructions.

## 2 Common Operations

This chapter explains common operations such as the functions of the buttons and how to use the menus. For more details, refer to the respective chapters below.

## 3 Taking Pictures

This chapter explains the various ways of capturing images and how to set the relevant functions.

## 4 Playing Back and Deleting Images

This chapter explains how to view still pictures and movies on the camera or on a TV screen and how to delete them from the camera.

## 5 Editing and Printing Images

This chapter explains how to edit still pictures on the camera and how to print them.

## 6 Recording and Playing Back Sound

This chapter explains how to record sound, add sound (a voice memo) to an image, and play them back.

## 7 Settings

This chapter explains how to set the camera-related functions.

## 8 Connecting to a Computer

This chapter explains how to connect the camera to a computer, and includes installation instructions and a general overview of the provided software.

## 9 Appendix

This chapter deals with troubleshooting and lists the optional accessories.

1

2

3

4

5

6

7

8

9

# Camera Features

In addition to basic picture-taking, the Optio S1 has a variety of shooting modes to suit different situations. This section describes how to make the most of the key features of your camera. Together with the explanations of camera operations, it will enable you to enjoy your camera to the full.

## Easy-to-Navigate Capture and Playback Functions!

The user-friendly design of the Optio S1 enables easy operation with only a few buttons. Simply by choosing the appropriate icon, you can select the shooting mode (p.67) and choose the optimal settings for the situation, or the playback mode (p.120, p.136) and enjoy the various playback and editing functions. A guide on the display lets you check the functions available in each mode and how to use them.



- **A shooting mode guide is displayed in the Capture Mode Palette and a playback mode guide in the Playback Mode Palette (p.67, p.120).**
- **Use the Green Mode to take pictures easily using standard settings (p.72).**



## Perfect for Portrait Shots!

The Optio S1 comes with a “Face Detection” function that spots the faces in your shot and automatically adjusts the focus and exposure for the faces. It can detect up to 16 people per shot, so it will help you take perfect group shots too. It will automatically release the shutter when people are smiling, or if anyone blinked, it will tell you that so you can take the shot again until it is perfect.

- **Face Detection function (p.69)**
- **Modes for taking stunning pictures of people (p.76)**

## Add Fun Frames to Your Pictures!

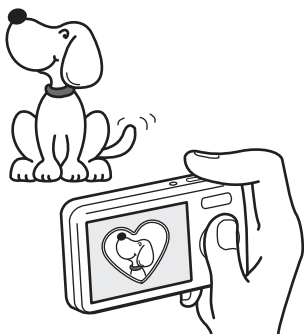

When you take a picture with the Optio S1, you can choose from our original fun frames to create attractive framed shots (p.80). You can also add frames to pictures you have taken. Adjust the position of the subject in the picture or reduce or enlarge the picture size to match the frame shape and size. Now you no longer have to worry about the subject not fitting into the frame (p.145).

- **For decorating your pictures with a frame**

## Display Your Data in Calendar Format!

With the Optio S1, you can display recorded images and movies by date in calendar format (p.119). This lets you quickly find the image or movie you want to play back.

## Advanced Movie Recording Functions

The Optio S1 has a “Movie SR” function to reduce camera shake during movie recording (p.112), and it enables you to record movies in 1280×720 pixel (16:9) HDTV format (\*) (p.111).

\* When connecting to and playing back images on AV equipment, the recorded data is output at normal screen resolution. To view movies in HDTV, transfer the data to a computer and play it back on the computer.

- **Use the camera to shoot fun-filled movies of your children or pets as a visual diary of their development (p.109).**

## A Multitude of Functions Inside the Camera for Enjoying Images Without a Computer!

The Optio S1 has a variety of functions to let you enjoy playing back and editing images without having to connect the camera to your computer. The camera is all you need to take and edit still pictures and movies (p.136).

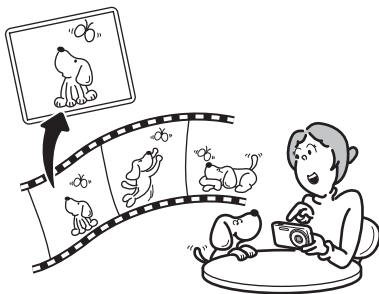

- **Image processing features such as Resize (p.136), Cropping (p.137), Digital Filter (p.140) and Red-eye Compensation (p.144) can be used.**
- **You can divide a movie into two or more segments and select a frame from a movie to save it as a still picture (p.148).**

## Checking the Contents of the Package



Camera  
Optio S1

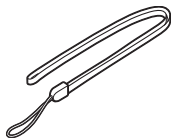

Strap  
O-ST116 (\*)

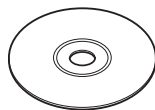

Software (CD-ROM)  
S-SW116

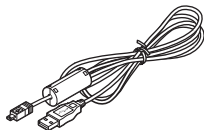

USB cable  
I-USB116 (\*)

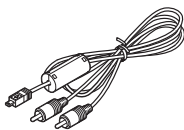

AV cable  
I-AVC116 (\*)



Rechargeable lithium-ion  
battery D-LI78 (\*)

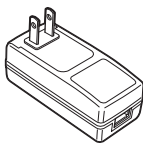

Power adapter  
D-PA116 (\*)



Quick Guide



Operating Manual  
(this manual)

Items marked with an asterisk (\*) are also available as optional accessories. For other optional accessories, refer to "Optional Accessories" (p.208).

## Names of Parts

### Front

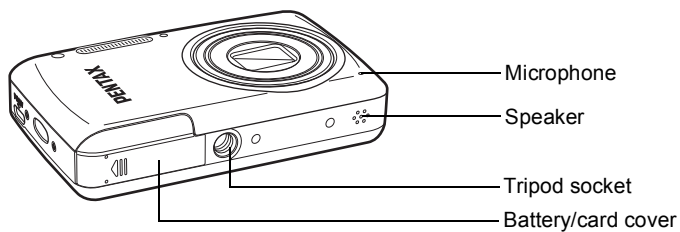
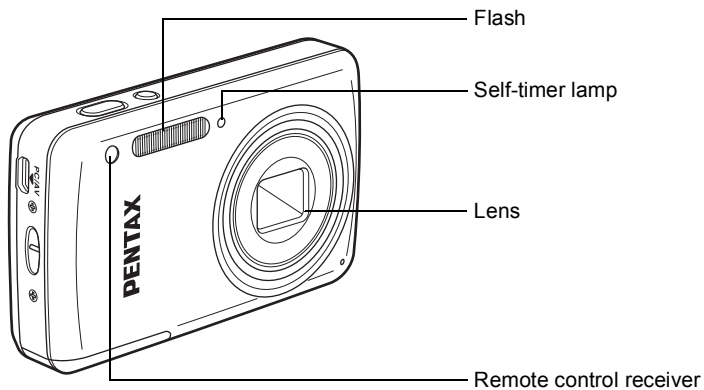

## Back

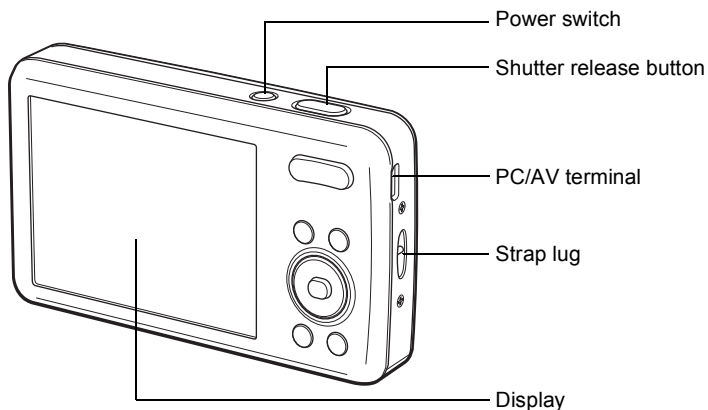

## Names of Operating Parts

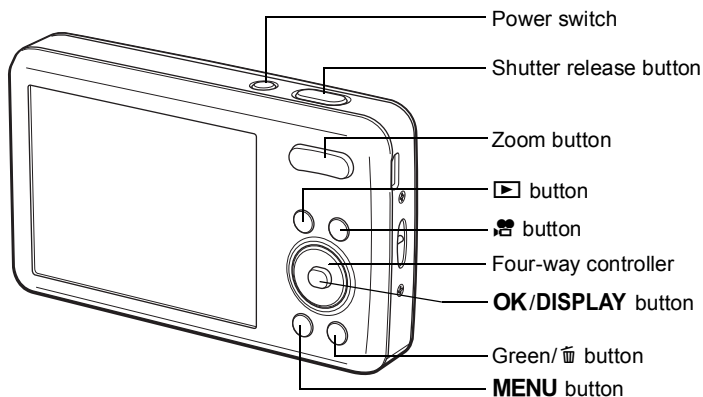



Refer to “Understanding the Button Functions” (p.50 - p.53) for an explanation of the function of each button.

# Monitor Indications

## Display in Mode

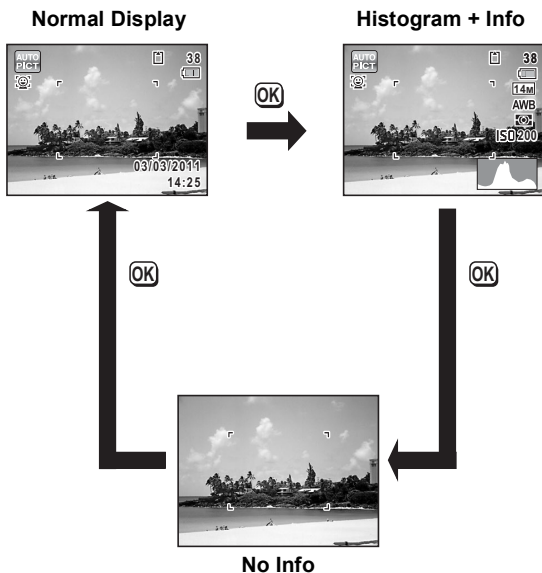
The display shows information such as the shooting conditions in the capture mode. The display changes in the following sequence each time you press the **OK/DISPLAY** button: “Normal Display”, “Histogram + Info” and “No Info”.



When the shooting mode is set to  (Green) mode, the monitor display is as shown on the right. You cannot change the information on the display by pressing the **OK/DISPLAY** button (p.72).



## Normal Display in Still Picture Capture Mode

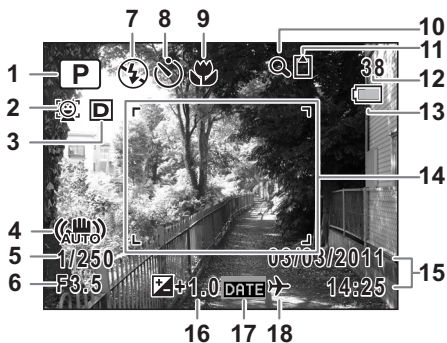



- |  |                                     |
|--|-------------------------------------|
| 1 Shooting mode (p.67)                       | 11 Memory status (p.40)             |
| 2 Face Detection mode (p.69)                 | 12 Remaining image storage capacity |
| 3 D-Range Setting (p.95)                     | 13 Battery level indicator (p.35)   |
| 4 Shake Reduction setting (p.102)            | 14 Focus frame (p.64)               |
| 5 Shutter speed                              | 15 Current date and time (p.46)     |
| 6 Aperture                                   | 16 EV Compensation (p.94)           |
| 7 Flash Mode (p.88)                          | 17 Date Imprint setting (p.106)     |
| 8 Drive Mode (p.84, p.85)                    | 18 World Time setting (p.168)       |
| 9 Focus Mode (p.89)                          |                                     |
| 10 Digital Zoom/Intelligent Zoom icon (p.73) |                                     |

\* 2 varies depending on the [Face Detection] setting in the [📷 Rec. Mode] menu.

	When [Face Detection] is set to [On]
	When [Face Detection] is set to [Smile]



If set to [Off], nothing appears in 2.

- \* 3 varies depending on the [D-Range Setting] setting in the [📷 Rec. Mode] menu.

	When [Highlight Correction] is set to <input checked="" type="checkbox"/> (On)
	When [Shadow Correction] is set to <input checked="" type="checkbox"/> (On)
	When [Highlight Correction] and [Shadow Correction] are both set to <input checked="" type="checkbox"/> (On)

If [Highlight Correction] and [Shadow Correction] are both set to  (Off), nothing appears in 3.

- \* 4 varies depending on the following conditions.

	When [Shake Reduction] in the [📷 Rec. Mode] menu is set to <input checked="" type="checkbox"/> (On)
	When [Shake Reduction] is set to <input type="checkbox"/> (Off) (If the camera shake is likely to occur,  is indicated when the shutter button is pressed halfway.)

- \* 5 and 6 appear only when the shutter release button is pressed halfway.
- \* For 9, when the focus mode is set to **AF** and the Auto-Macro function is activated, the  appears on the display (p.89).
- \* Some indications may not appear depending on the shooting mode.

### Histogram + Info/No Info Display in Still Picture Capture Mode

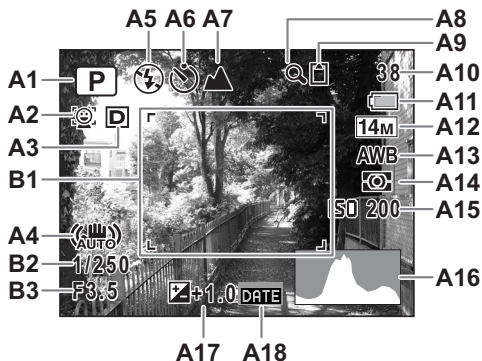

A1 to A18 and B1 appear when “Histogram + Info” is selected. Only B1 appears when “No Info” is selected.







- A1** Shooting mode (p.67)
- A2** Face Detection mode (p.69)
- A3** D-Range Setting (p.95)
- A4** Shake Reduction setting (p.102)
- A5** Flash Mode (p.88)
- A6** Drive Mode (p.84, p.85)
- A7** Focus Mode (p.89)
- A8** Digital Zoom/  
Intelligent Zoom icon (p.73)
- A9** Memory status (p.40)
- A10** Remaining image storage capacity
- A11** Battery level indicator (p.35)
- A12** Recorded Pixels (p.92)
- A13** White Balance (p.96)
- A14** AE Metering (p.98)
- A15** Sensitivity (p.99)
- A16** Histogram (p.26)
- A17** EV Compensation (p.94)
- A18** Date Imprint setting (p.106)
- B1** Focus frame (p.64)
- B2** Shutter speed
- B3** Aperture

\* A2 varies depending on the [Face Detection] setting in the [📷 Rec. Mode] menu.

	When [Face Detection] is set to [On]
	When [Face Detection] is set to [Smile]



If set to [Off], nothing appears in A2.

\* A3 varies depending on the [D-Range Setting] setting in the [📷 Rec. Mode] menu.

	When [Highlight Correction] is set to <input checked="" type="checkbox"/> (On)
	When [Shadow Correction] is set to <input checked="" type="checkbox"/> (On)
	When [Highlight Correction] and [Shadow Correction] are both set to <input checked="" type="checkbox"/> (On)

If [Highlight Correction] and [Shadow Correction] are both set to  (Off), nothing appears in A3.

\* A4 varies depending on the following conditions.

	When [Shake Reduction] in the [📷 Rec. Mode] menu is set to <input checked="" type="checkbox"/> (On)
	When [Shake Reduction] is set to <input type="checkbox"/> (Off) (If the camera shake is likely to occur,  is indicated when the shutter button is pressed halfway.)

\* B2 and B3 appear only when the shutter release button is pressed halfway.

\* When the shooting mode is  (Auto Picture) and if you press the shutter release button halfway, the automatically selected shooting mode appears in A1 even when “No Info” is selected (p.70).

\* Some indications may not appear depending on the shooting mode.

## Display in Mode

The display shows the shooting information of the image in the playback mode. The display changes in the following sequence each time you press the **OK/DISPLAY** button: “Normal Display”, “Histogram + Info” and “No Info”.

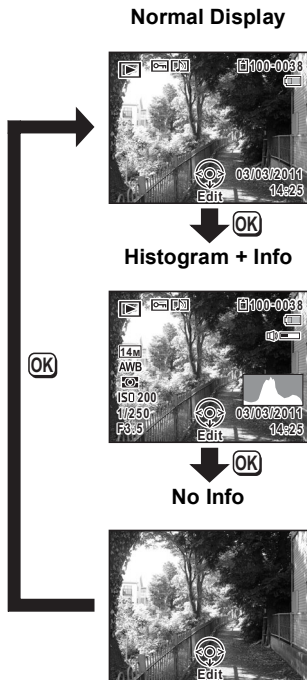

## Normal Display/Histogram + Info Display in Playback Mode

(All of the display items are displayed here for explanatory purposes.)

The display shows information such as the shooting conditions. A1 to A10 appear when “Normal Display” or “Histogram + Info” is selected. B1 to B7 appear only when “Histogram + Info” is selected.



- |  |   |
|--|---|
| <b>A1</b> Playback mode                  | <b>A8</b> Volume icon                   |
| ▶ : Still picture (p.116)                | <b>A9</b> Captured date and time (p.46) |
| ▶ : Movie (p.117)                        | <b>A10</b> Four-way controller guide    |
| ▶ : Sound (p.159)                        | <b>B1</b> Recorded Pixels (p.92)        |
| <b>A2</b> Protect icon (p.129)           | <b>B2</b> White Balance (p.96)          |
| <b>A3</b> Voice memo icon (p.162)        | <b>B3</b> AE Metering (p.98)            |
| <b>A4</b> Memory status (p.40)           | <b>B4</b> Sensitivity (p.99)            |
| <b>A5</b> Folder number (p.172)          | <b>B5</b> Shutter speed                 |
| <b>A6</b> File number                    | <b>B6</b> Aperture                      |
| <b>A7</b> Battery level indicator (p.35) | <b>B7</b> Histogram (p.26)              |

\* In “Normal Display”, A7 and A9 disappear if no operation is performed for two seconds.

\* A8 appears only when the volume is being adjusted during playback of movies, sound files or voice memos (p.117, p.159, p.162).

\* A10 appears even when “No Info” is selected, but disappears if no operation is performed for two seconds. When no operation is performed for two seconds in “Normal Display” or “Histogram + Info”, only “Edit” disappears.

## Guide Indications

A guide indication for each available button/key operation appears as follows on the display during operation.

▲	Four-way controller (▲)
▼	Four-way controller (▼)
◀	Four-way controller (◀)
▶	Four-way controller (▶)
<b>MENU</b>	<b>MENU</b> button

	Zoom button
<b>OK</b>	<b>OK/DISPLAY</b> button
<b>SHUTTER</b>	Shutter release button
	Green/ button

## Using the Histogram

A histogram shows the brightness distribution of an image. The horizontal axis represents brightness (dark at the left and bright at the right) and the vertical axis represents the number of pixels.

The shape of the histogram before and after shooting tells you whether the brightness and contrast are correct or not, and lets you decide if you need to adjust the exposure and take a picture again.

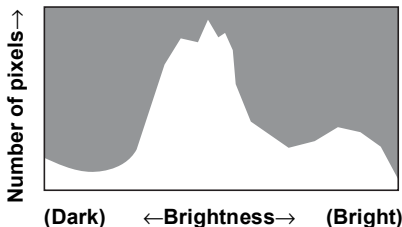

Compensating for Exposure (EV Compensation) p.94

## Understanding Brightness

If the brightness is correct, the graph peaks in the middle. If the image is underexposed, the peak is on the left side, and if it is overexposed, the peak is on the right side.

Dark image

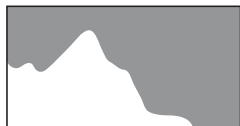

Correct image

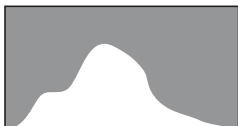

Bright image

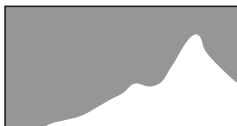

When the image is underexposed, the part to the left is cut off (dark portions) and when the image is overexposed, the part to the right is cut off (bright portions).

### **Understanding Contrast**

The graph peaks gradually for images in which contrast is balanced. The graph peaks on both sides but sinks in the middle for images with a large difference in contrast and low amounts of mid-level brightness.

## Memo

# 1 Getting Started

---

<b>Attaching the Strap .....</b>	<b>30</b>
<b>Powering the Camera .....</b>	<b>31</b>
<b>Installing an SD Memory Card .....</b>	<b>36</b>
<b>Turning the Camera On and Off .....</b>	<b>40</b>
<b>Initial Settings .....</b>	<b>42</b>

# Attaching the Strap

Attach the strap (O-ST116) supplied with the camera.

1

Getting Started

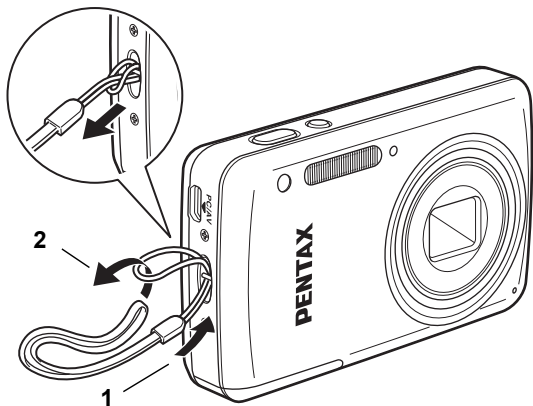

- 1** Pass the narrow end of the strap through the strap lug.
- 2** Pass the other end of the strap through the loop and pull tight.



## Installing the Battery

Use the rechargeable lithium-ion battery D-LI78 that is provided with the camera.

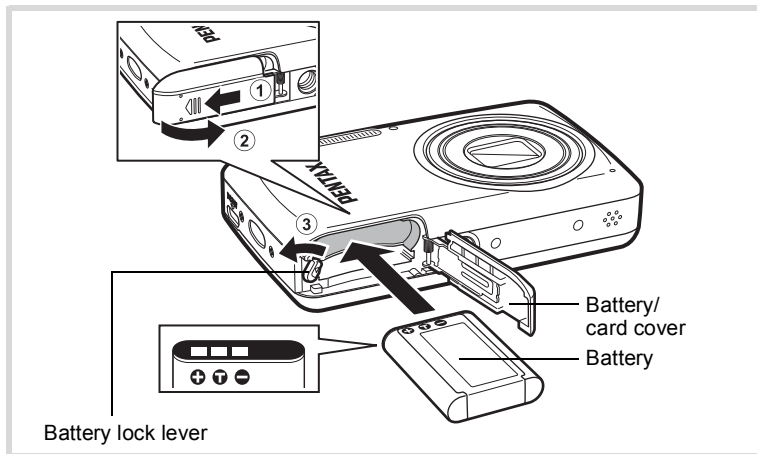

- 1 Make sure that the camera is turned off and open the battery/card cover.**  
Slide the battery/card cover in the direction indicated by the arrow ① and flip the cover open ②.
- 2 Push the battery lock lever in the direction of the arrow ③ and insert the battery so that the PENTAX logo is facing toward the screen display.**  
Match the marks on the battery to the marks inside the battery compartment and push the battery in until it is locked in place.



Make sure that the battery is inserted with the PENTAX logo facing toward the screen display. If the battery is incorrectly oriented, malfunction may result.

### 3 Close the battery/card cover.

Slide the battery/card cover in the opposite direction indicated by ①. When you hear a click, the cover is securely closed.

Charge the battery before using it in the camera for the first time. (p.33)

## To Remove the Battery

### 1 Make sure that the camera is turned off and open the battery/card cover.

### 2 Push the battery lock lever in the direction of the arrow ③.

The battery will be ejected. Take care not to drop the battery when removing it.



- This camera uses a rechargeable lithium-ion battery D-LI78. Use of any other type of battery may damage the camera and cause a malfunction.
- Insert the battery correctly. If the battery is incorrectly oriented, malfunction may result.
- When storing the battery for more than 6 months, charge the battery for 30 minutes and store the battery separately from the camera. Be sure to recharge the battery every 6 to 12 months. Storing the battery at or below room temperature is ideal. Avoid storing it at high temperature.
- The date and time may be returned to the default setting if the camera is left without the battery for a long time.
- Be careful as the camera or the battery may become hot when the camera is used continuously for a long period of time.

## Charging the Battery

Charge the battery from a power outlet using the provided power adapter (D-PA116) and USB cable (I-USB116) before using it for the first time, after a long period of non-use, or when the [Battery depleted] message appears.

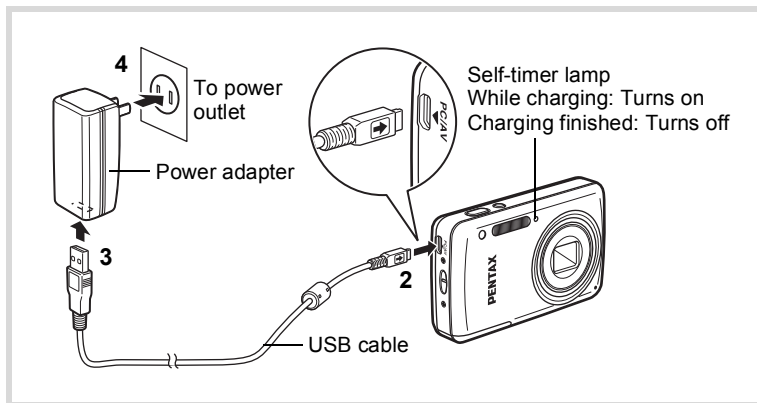

- 1** Make sure that the battery is installed in the camera.
- 2** Face the ➔ mark on the USB cable towards the ◀ mark on the camera, and connect the cable to the PC/AV terminal.
- 3** Connect the other end of the USB cable to the power adapter.
- 4** Plug the power adapter into the power outlet.  
The self-timer lamp turns on while the battery is charging and turns off when charging is finished.
- 5** Unplug the power adapter from the power outlet, and disconnect the USB cable from your camera.



- Do not use the power adapter D-PA116 to charge batteries other than the rechargeable lithium-ion battery D-LI78, as the adapter may overheat or be damaged.
- Make sure that the battery has been inserted correctly and the cable is connected properly if the self-timer lamp blinks.
- Replace the battery with a new one in the following cases:
  - If the battery starts to run down more quickly (the battery may have reached the end of its service life)
  - If the self-timer lamp does not light or blinks even after being charged (the battery may be faulty)



- The time required to fully charge the battery is about 140 minutes (max.). (The charging time may vary depending on the ambient temperature and charging conditions.) The appropriate ambient temperature for charging the battery is 0°C to 40°C (32°F to 104°F).
- The rechargeable lithium-ion battery D-LI78 can also be charged using the optional battery charger D-BC78.
- Do not attempt to charge the battery by connecting the USB cable to a computer, etc.

### • Image Storage Capacity, Movie Recording Time, Sound Recording Time, and Playback Time (at 23°C with the display on and the battery fully charged)

Image Storage Capacity <sup>*1</sup> (flash used for 50% of shots)	Movie Recording Time <sup>*2</sup>	Sound Recording Time <sup>*2</sup>	Playback Time <sup>*2</sup>
Approx. 180 pictures	Approx. 70 min.	Approx. 110 min.	Approx. 120 min.

\*1 Image Storage Capacity shows the approximate number of shots recorded during CIPA-compliant testing (with display on, flash used for 50% of the shots, and 23 degrees centigrade). Actual performance may vary according to operating conditions.





\*2 According to the result of in-house testing.



- In general, battery performance may temporarily deteriorate as the temperature decreases.
- Be sure to take a spare battery with you when traveling abroad or to a cold region, or if you intend to take a lot of pictures.

## • Battery Level Indicator

You can check the battery level by the indicator on the display.

Screen Display	Battery Status
 (green)	Adequate power remains.
 (green)	Battery is running low.
 (yellow)	Battery is running very low.
 (red)	Battery is exhausted.
[Battery depleted]	The camera will turn off after this message appears.

# Installing an SD Memory Card

1

Getting Started

This camera uses a commercially available SD Memory Card, SDHC Memory Card, or SDXC Memory Card. (These cards are referred to as SD Memory Cards hereafter.) Captured images and sound files are saved on the SD Memory Card when a card is inserted in the camera. They are saved in the built-in memory when a card is not inserted (p.40).



**Be sure to use this camera to format (initialize) an SD Memory Card that is unused or has been used on other cameras or digital devices. Refer to “Formatting an SD Memory Card” (p.164) for instructions on formatting.**



- The still picture storage capacity and movie recording time vary depending on the capacity of the SD Memory Card and the selected number of recorded pixels (p.39).
- The self-timer lamp blinks while the SD Memory Card is being accessed (data is being recorded or read).

## Backing Up Data

The camera may not be able to access data in the SD Memory Card or built-in memory in the case of a malfunction. Use a computer or other device to back up important data in another location.

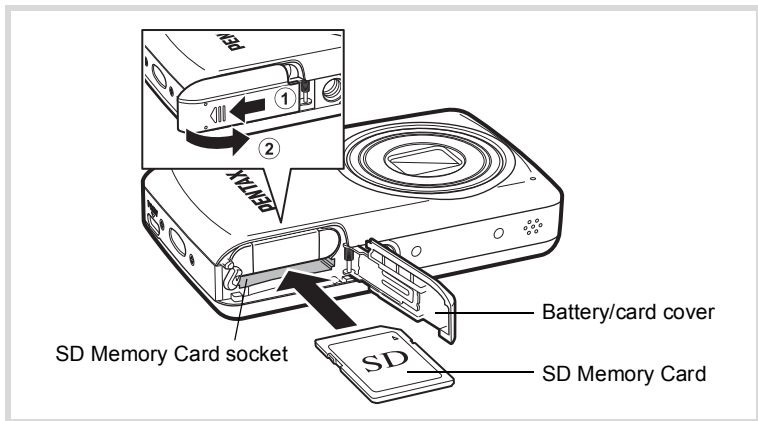

**1 Make sure that the camera is turned off and open the battery/card cover.**

Slide the battery/card cover in the direction indicated by the arrow ① and flip the cover open ②.

**2 Insert the SD Memory Card into the SD Memory Card socket so that the label is facing toward the front of the camera (the side with the lens).**

Push the card in until it clicks. Data may not be recorded correctly if the card is not inserted all the way.

**3 Close the battery/card cover.**

Slide the battery/card cover in the opposite direction indicated by ①. When you hear a click, the cover is securely closed.

### To Remove the SD Memory Card

**1 Make sure that the camera is turned off and open the battery/card cover.**

**2 Push the card into the SD Memory Card socket to eject it.**

Pull the card out.

## Precautions When Using an SD Memory Card

- The SD Memory Card is equipped with a write-protect switch. Setting the switch to LOCK prevents new data from being recorded on the card, the stored data from being deleted, and the card from being formatted by the camera or computer.
  - ☒ appears on the display when the card is write-protected.
- Care should be taken when removing the SD Memory Card immediately after using the camera, as the card may be hot.
- Keep the card cover closed and do not remove the card or turn the camera off while the data is being played back or saved to the card, or the camera is connected to a computer with the USB cable, as this may cause the data to be lost or the card to be damaged.
- Do not bend the SD Memory Card or subject it to violent impact. Keep it away from water and store away from high temperature.
- Do not remove the SD Memory Card during formatting as this may damage the card and render it unusable.
- The data on the SD Memory Card may be deleted in the following circumstances. We do not accept any liability for data that is deleted
  - (1) when the SD Memory Card is mishandled by the user.
  - (2) when the SD Memory Card is exposed to static electricity or electrical interference.
  - (3) when the SD Memory Card has not been used for a long time.
  - (4) when the SD Memory Card is ejected or the battery is removed while the data on the card is being recorded or accessed.
- If it is not used for a long time, the data on the card may become unreadable. Be sure to regularly make a backup of important data on a computer.
- Avoid using or storing the card where it may be exposed to static electricity or electrical interference.
- Avoid using or storing the card in direct sunlight or where it may be exposed to rapid changes in temperature or to condensation.
- When using an SD Memory Card with a slow recording speed, recording may stop while you are taking movies even when there is adequate space in the memory, or shooting and playback may take a long time.
- Be sure to format SD Memory Cards that are unused or have been used on another camera. Refer to “Formatting an SD Memory Card” (p.164).

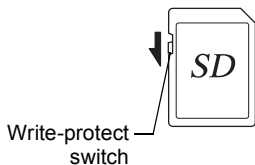





## Number of Recordable Images

The file sizes of the recorded images vary depending on the number of recorded pixels of the images, so the number of images that can be saved on an SD Memory Card or in the built-in memory also varies.

Choose the appropriate number of recorded pixels for still pictures on the [ Rec. Mode] menu.

Selecting the Number of Recorded Pixels  p.92

Choose the appropriate number of recorded pixels and frame rate on the [ Movie] menu.

Selecting the Recorded Pixels and Frame Rate for Movies  p.111

For an approximate guide to the number of images or the length of recorded movies that can be saved on an SD Memory Card or in the built-in memory, see “Main Specifications” (p.210).

# Turning the Camera On and Off

1

Getting Started

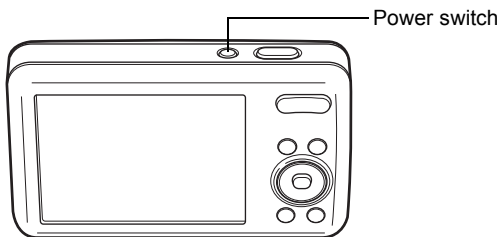

## 1 Press the power switch.

The camera turns on and the display turns on.

When you turn the camera on, the lens cover opens and the lens extends.

If the [Language/言語] screen or [Date Adjustment] screen appears when you turn the camera on, follow the procedure on p.42 to set the display language and/or current date and time.

## 2 Press the power switch again.

The display turns off, the lens closes, and the camera turns off.

Taking Still Pictures p.64

## Checking the SD Memory Card

The SD Memory Card is checked when the camera turns on and the memory status is displayed.

	The SD Memory Card is inserted. Images and sound files will be saved on the SD Memory Card.
	The SD Memory Card is not inserted. Images and sound files will be saved in the built-in memory.
	The write-protect switch on the SD Memory Card is in the LOCK position (p.38). Images and sounds cannot be recorded.

Memory status



## Starting-up in the Playback Mode

If you want to play back images or sound files straightaway without taking any pictures, you can start up the camera in the playback mode.

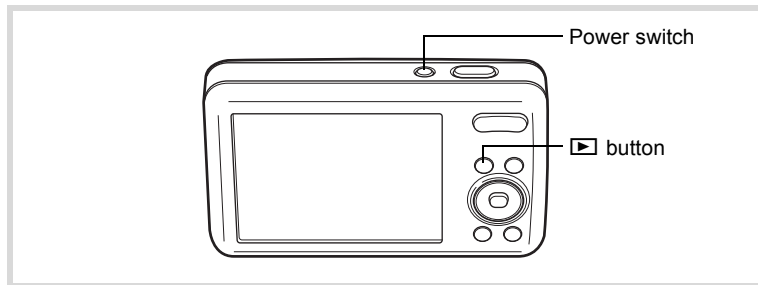

### 1 Press the power switch while holding down the ▶ button.

The display turns on with the lens retracted and the camera turns on in the playback mode.



To switch from the playback mode to the capture mode, press the ▶ button or press the shutter release button halfway.

Playing Back Still Pictures p.116

# Initial Settings

The [Language/言語] screen appears when the camera is turned on for the first time. Perform the operations in “Setting the Display Language” below to set the language, and in “Setting the Date and Time” (p.46) to set the current date and time.

The language, date, and time can be changed later. Refer to the pages below for instructions.

- To change the language, follow the steps in “Changing the Display Language” (p.171).
- To change the date and time, follow the steps in “Changing the Date and Time” (p.166).

## Setting the Display Language

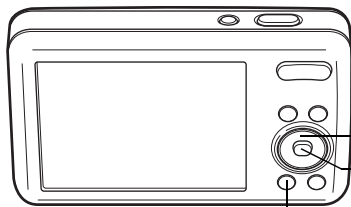

Four-way controller

OK button

MENU button

- 1 Use the four-way controller (▲▼◀▶) to choose the desired display language.

Language/言語		
English	日本語	Türkçe
Français	Dansk	Ελληνικά
Deutsch	Svenska	Русский
Español	Suomi	ไทย
Português	Polski	한국어
Italiano	Čeština	中文繁體
Nederlands	Magyar	中文简体
MENU Cancel		OK OK

## 2 Press the OK button.

The [Initial Setting] screen appears in the selected language. If the desired settings for [Hometown] and [DST] (Daylight Saving Time) appear, proceed to Step 3. Proceed to “To Set Hometown and DST” (p.45) if the desired settings do not appear.

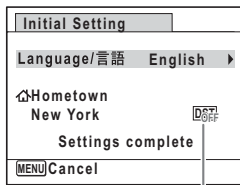

Daylight saving time

## 3 Press the four-way controller (▼) twice to select [Settings complete].

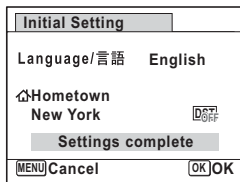

## 4 Press the OK button.

The [Date Adjustment] screen appears. Set the date and time by following the procedure in “Setting the Date and Time” (p.46).

If you accidentally select the wrong language and proceed to the next procedure, perform the following operation to set the desired language.

● **When the Wrong Language Has Been Inadvertently Selected**

- 1 Press the four-way controller (▶).**
- 2 Use the four-way controller (▲ ▼ ◀ ▶) to select the desired language and press the OK button.**

The [Initial Setting] screen appears in the selected language.

● **When the Screen After Step 2 Appears in the Wrong Language**

- 1 Press the MENU button.**  
The setting screen is canceled and the camera is set to still picture capture mode.
- 2 Press the MENU button.**  
The [📷 Rec. Mode] menu appears.
- 3 Press the four-way controller (▶) twice.**  
The [↶ Setting] menu appears.
- 4 Use the four-way controller (▲ ▼) to select [Language/言語].**
- 5 Press the four-way controller (▶).**  
The [Language/言語] screen appears.
- 6 Use the four-way controller (▲ ▼ ◀ ▶) to select the desired language.**
- 7 Press the OK button.**  
The [↶ Setting] menu appears in the selected language.

To reset the Hometown city, date, and time, refer to the pages below for instructions.

- To change the Hometown city, follow the steps in “Setting the World Time” (p.168).
- To change the date and time, follow the steps in “Changing the Date and Time” (p.166).

## To Set Hometown and DST

- 3** Press the four-way controller (▼).

The frame moves to [Hometown].

- 4** Press the four-way controller (▶).

The [Hometown] screen appears.

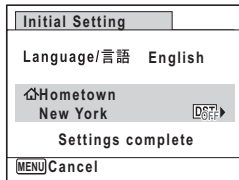

- 5** Use the four-way controller (◀▶) to choose a city.

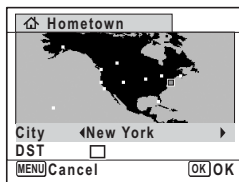

- 6** Press the four-way controller (▼).

The frame moves to [DST] (Daylight Saving Time).

- 7** Use the four-way controller (◀▶) to select  (On) or  (Off).

- 8** Press the OK button.

The [Initial Setting] screen reappears.

- 9** Press the four-way controller (▼) to select [Settings complete].

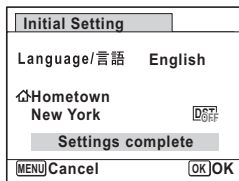

- 10** Press the OK button.

The [Date Adjustment] screen appears. Next, set the date and time.

The video output format (NTSC/PAL) is set to the format of the city selected in [Hometown] on the [Initial Setting] screen. Refer to “List of World Time Cities” (p.207) for the video output format of each city that will be set at the time of initial setting, and “Changing the Video Output Format” (p.173) for changing the video output format.

## Setting the Date and Time

Set the current date and time and the display style.

### 1 Press the four-way controller (▶).

The frame moves to [mm/dd/yy].

### 2 Use the four-way controller (▲▼) to choose the date format.

Choose from [mm/dd/yy], [dd/mm/yy] or [yy/mm/dd].

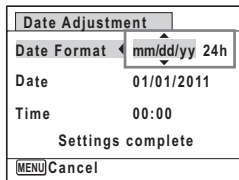

### 3 Press the four-way controller (▶).

The frame moves to [24h].

### 4 Use the four-way controller (▲▼) to select [24h] (24-hour display) or [12h] (12-hour display).

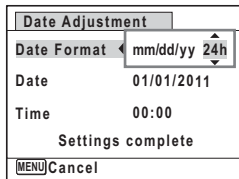

### 5 Press the four-way controller (▶).

The frame returns to [Date Format].

### 6 Press the four-way controller (▼).

The frame moves to [Date].



## 7 Press the four-way controller (▶).

The frame moves to the month.

## 8 Use the four-way controller (▲▼) to change the month.

Change the day and year in the same manner.

Next, change the time.

If you selected [12h] in Step 4, the camera automatically switches the display between am and pm corresponding to the time.

Date Adjustment	
Date Format	mm/dd/yy 24h
Date	01/01/2011
Time	00:00
Settings complete	
[MENU] Cancel	

## 9 Press the four-way controller (▼) to select [Settings complete].

Date Adjustment	
Date Format	mm/dd/yy 24h
Date	01/01/2011
Time	00:00
Settings complete	
[MENU] Cancel	[OK] OK

## 10 Press the OK button.

This confirms the date and time.



If you press the **OK** button in Step 10, the camera clock is reset to 0 seconds. To set the exact time, press the **OK** button when the time signal (on the TV, radio, etc.) reaches 0 seconds.



When the [Initial Setting] or [Date Adjustment] screen is displayed, you can cancel the settings made up to that point and switch to the capture mode by pressing the **MENU** button. In this case, the [Initial Setting] screen will appear again the next time you turn the camera on.

The language, date, time, Hometown city, and DST setting can be changed. Refer to the pages below for instructions.

- To change the language, follow the steps in "Changing the Display Language" (p.171).
- To change the date and time, follow the steps in "Changing the Date and Time" (p.166).
- To change the Hometown city or DST setting, follow the steps in "Setting the World Time" (p.168).

## Memo

# **2 Common Operations**

---

<b>Understanding the Button Functions .....</b>	<b>50</b>
<b>Setting the Camera Functions .....</b>	<b>55</b>

# Understanding the Button Functions

## Mode

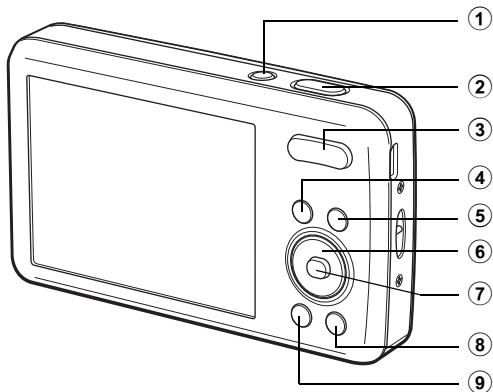

- ① **Power switch**  
Turns the camera on and off (p.40).
- ② **Shutter release button**  
Focuses the camera on the subject when pressed halfway in still picture capture mode (except in **PF**, **▲** and **MF** modes).  
Takes a still picture when pressed down fully (p.65).  
Starts and stops sound file recording in Voice Recording (p.159).
- ③ **Zoom button**  
Changes the area captured by the camera (p.73).  
Switches to the [📷 Rec. Mode] menu, [🎥 Movie] menu, or [⚙️ Setting] menu when a menu screen is displayed.
- ④ **▶️ button**  
Switches to the ▶️ mode (p.54).

- ⑤ **REC button**  
Starts and stops movie recording (p.109).
- ⑥ **Four-way controller**
- ▲ Changes the drive mode (p.84, p.85).
  - ▼ Displays the Capture Mode Palette (p.67).
  - ◀ Changes the flash mode (p.88).
  - ▶ Changes the focus mode (p.89).
  - ▲▼ Adjusts the focus when the focus mode is set to **MF** (p.90).
- ⑦ **OK/DISPLAY button**  
Changes the information on the display (p.20).
- ⑧ **Green button**  
Switches to the **■** (Green) mode (p.72).  
Calls up the assigned function (p.107).
- ⑨ **MENU button**  
Displays the [**☑** Rec. Mode] menu (p.55).

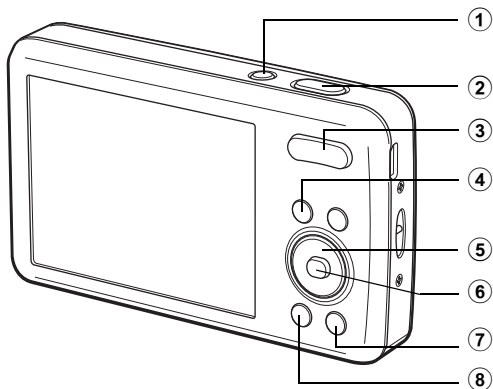



① **Power switch**



Turns the camera on and off (p.40).

② **Shutter release button**

Switches to  mode (p.54).

③ **Zoom button**

Press towards the left () during single-image display to change to four-image display. Changes to nine-image display when pressed towards the left again. Returns to the previous display when pressed towards the right () (p.118).

Enlarges the image when pressed towards the right () during single-image display. Returns to the previous display when pressed towards the left () (p.125).

Press towards the left () during nine-image display to change to folder or calendar display (p.119).

Press towards the right () during folder/calendar display to change to nine-image display (p.119).

Adjusts the volume during playback of movies, sound files or voice memos (p.117, p.159, p.162).

④ **▶ button**

Switches to  mode (p.54).

## ⑤ Four-way controller

- ▲ Plays back and pauses a movie or sound file (p.117, p.159).
- ▼ Displays the Playback Mode Palette (p.120). Stops a movie or sound file during playback (p.117, p.159).
- ◀▶ Displays the previous or next image or sound file during single-image display (p.116).  
Fast-forwards, fast-reverses, frame forwards, frame reverses, plays back a movie in forward and reverse during movie playback (p.117).  
Fast-forwards, fast-reverses, and moves to the next index during sound playback (p.159).
- ▲▼◀▶ Selects an image during four-/nine-image display, a folder during folder display, and a date during calendar display (p.118, p.119).  
Moves the display area during zoom display (p.125).  
Moves the image when using the Frame Composite function (p.145).

## ⑥ OK/DISPLAY button

- Changes the information on the display (p.24).
- Returns to single-image display during four-/nine-image display or zoom display (p.118, p.125).
- Changes to nine-image display of the selected folder during folder display (p.119).
- Changes to single-image display of the selected date during calendar display (p.119).



## ⑦ Green/🗑️ button

- Switches from single-image display to the Delete screen (p.126).
- Switches from four-/nine-image display to the Select & Delete screen (p.127).
- Switches from folder display to the calendar display screen (p.119).
- Switches from calendar display to the folder display screen (p.119).

## ⑧ MENU button

- Displays the [⏏ Setting] menu during single-image display (p.55).
- Returns to single-image display during Playback Mode Palette display (p.120).
- Returns to single-image display during four-/nine-image display or zoom display (p.118).
- Changes to nine-image display during folder or calendar display (p.119).

## Switching Between Mode and Mode

In this manual, the capture mode, such as for taking still pictures, is referred to as “ mode” (the capture mode). The playback mode, such as for viewing the captured images on the display, is referred to as “ mode” (the playback mode). In  mode, you can perform simple editing operations on the captured images.

Follow the procedure below to switch between  mode and  mode.

### To Switch from Mode to Mode

#### 1 Press the button.

The camera switches to  mode.

### To Switch from Mode to Mode

#### 1 Press the button or the shutter release button halfway.

The camera switches to  mode.

### Displaying the data stored in the built-in memory

When an SD Memory Card is inserted in the camera, images, movies, and sound files stored on the SD Memory Card are displayed.

If you want to display images, movies and sound files stored in the built-in memory, turn the camera off first, and then remove the SD Memory Card before proceeding.



Make sure that the camera is turned off before inserting or removing the SD Memory Card.



# Setting the Camera Functions

To change the camera settings, press the **MENU** button to display the menu screens. Functions for playing back and editing images and sound files are called up from the Playback Mode Palette (p.120).

## Operating the Menus

There are three menus available with the camera: [📷 Rec. Mode], [🎥 Movie], and [⚙️ Setting].

Press the **MENU** button in 📷 mode to display the [📷 Rec. Mode] menu. Press the **MENU** button in 🎥 mode to display the [⚙️ Setting] menu. Use the four-way controller (◀▶) or zoom button to switch between the menus.

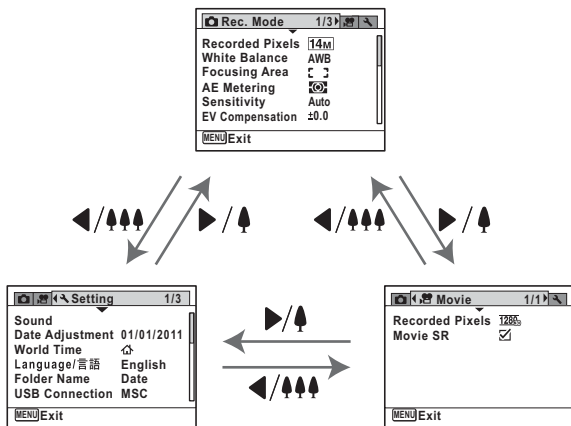

Available button operations appear on the display during menu operation (p.26).

## Ex.) To set [Focusing Area] on the [Rec. Mode] menu

### 1 Press the MENU button in camera mode.

The [Rec. Mode] menu appears.

### 2 Press the four-way controller (▼).

The frame moves to [Recorded Pixels].

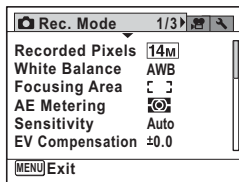

### 3 Press the four-way controller (▼) twice.

The frame moves to [Focusing Area].

### 4 Press the four-way controller (▶).

A pull-down menu appears only with the items that are available with the current camera settings.

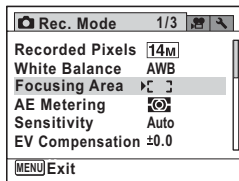

### 5 Use the four-way controller (▲▼) to change the setting.

The focusing area changes each time the four-way controller (▲▼) is pressed.

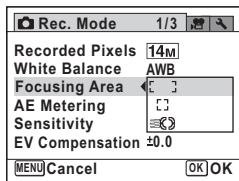

### 6 Press the OK button or the four-way controller (◀).

The setting is saved and then the camera is ready for setting the other functions.

To exit the setting operation, press the MENU button.

To perform another operation, refer to the following alternate Step 6 options.

## To Save the Setting and Start Taking Pictures

### 6 Press the shutter release button halfway.

The setting is saved and the camera returns to capture status. When the shutter release button is pressed fully, the picture is taken.



When the [ Setting] menu is displayed from mode, you can switch to mode by pressing the button.

## To Save the Setting and Start Playback of Images

### 6 Press the button.

When the [ Rec. Mode] menu is displayed from mode, the setting is saved and the camera returns to playback status.

## To Cancel the Changes and Continue with Menu Operations

### 6 Press the MENU button.

The changes are canceled and the screen shown in Step 3 reappears.



The **MENU** button function varies depending on the screen. Refer to the guide indications.

- |        |   |
|--------|---|
| Exit   | Exits the menu and returns to the original screen.                                |
|        | Returns to the previous screen with the current setting.                          |
| Cancel | Cancels the current selection, exits the menu and returns to the previous screen. |

## Menu List

This displays the items that can be set from the menus and provides descriptions of each item. See the list of default settings in the Appendix “Default Settings” (p.202) to check whether the settings are saved when the camera is turned off and whether the settings return to the defaults when the camera is reset.

### [📷 Rec. Mode] Menu

Item	Description	Page
Recorded Pixels	For choosing the number of recorded pixels of still pictures	p.92
White Balance	For adjusting the color balance according to the light conditions	p.96
Focusing Area	For changing the autofocus area	p.91
AE Metering	For setting the area of the screen that is metered to determine the exposure	p.98
Sensitivity	For setting the sensitivity	p.99
EV Compensation	For adjusting the overall brightness of the picture	p.94
D-Range Setting	Highlight Correction For adjusting the bright areas when the image is overexposed	p.95
	Shadow Correction For adjusting the dark areas when the image is underexposed	
Shake Reduction	For choosing whether to correct camera shake when taking still pictures	p.102
Face Detection	For spotting the faces in your shot and automatically adjusting the focus and exposure for the faces	p.100
Blink Detection	For choosing whether to use the Blink Detection function when the Face Detection function is activated	
Digital Zoom	For choosing whether or not to use the Digital Zoom function	p.74
Instant Review	For choosing whether to display Instant Review	p.103
Memory	For choosing whether to save the set values of the shooting function or return to the defaults when the camera is turned off	p.113
Green Button	For assigning a function to the Green button so that you can go straight to it in 📷 mode	p.107
Sharpness	For choosing sharp or soft outlines	p.104
Saturation	For setting the color saturation	p.105
Contrast	For setting the image contrast level	p.105
Date Imprint	For choosing whether to imprint the date and/or time when taking still pictures	p.106

## ● [📷 Rec. Mode] Menu 1

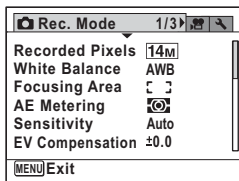

## ● [📷 Rec. Mode] Menu 2

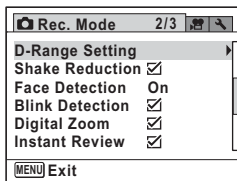

## ● [📷 Rec. Mode] Menu 3

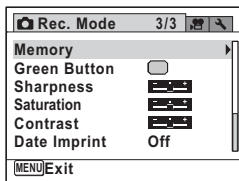

- Use the **●** (Green) mode to enjoy easy picture-taking using standard settings, regardless of the settings in the [📷 Rec. Mode] menu (p.72).
- Assigning a frequently used function to the Green button enables you to go straight to the desired function (p.107).

## [📽 Movie] Menu

Item	Description	Page
Recorded Pixels	For choosing the number of recorded pixels of movies	p.111
Movie SR	For choosing whether or not to use the movie shake reduction function	p.112

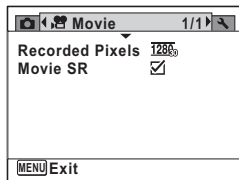

## [ Setting] Menu

Item	Description	Page
Sound	For adjusting the operation volume and playback volume, and setting the start-up sound, shutter sound, key operation sound and self-timer sound	p.165
Date Adjustment	For adjusting the date and time	p.166
World Time	For setting the Hometown city and Destination city	p.168
Language/言語	For setting the language in which menus and messages appear	p.171
Folder Name	For choosing how names are assigned to folders for storing images and sound files	p.172
USB Connection	For setting the USB connection mode (MSC or PTP) when connected to a computer via the USB cable	p.182
Video Out	For setting the output format to AV equipment	p.173
Brightness Level	For changing the brightness of the display	p.174
Power Saving	For setting the time until the camera enters the power-saving mode	p.175
Auto Power Off	For setting the time until the camera turns off automatically	p.176
Reset	For returning settings to their defaults	p.179
Delete All	For deleting all the saved images and sound files at once	p.128
Pixel Mapping	For mapping out and correcting any defective pixels in the CCD sensor	p.178
Format	For formatting an SD Memory Card	p.164

- [↶ Setting] Menu 1



- [↶ Setting] Menu 2

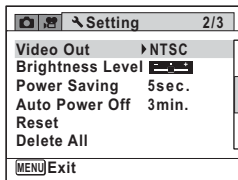

- [↶ Setting] Menu 3

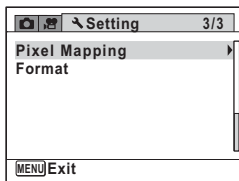

## Memo



# **3 Taking Pictures**

---

<b>Taking Still Pictures .....</b>	<b>64</b>
<b>Setting the Shooting Functions .....</b>	<b>88</b>
<b>Recording Movies .....</b>	<b>109</b>
<b>Saving the Settings (Memory) .....</b>	<b>113</b>

# Taking Still Pictures

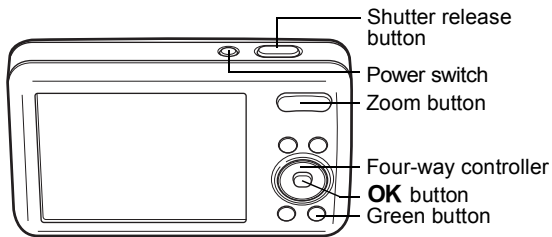

3

Taking Pictures

## Taking Pictures

The Optio S1 features a wide range of shooting modes and functions to suit almost any subject or scene. This chapter describes how to take pictures with the most commonly used standard settings (the factory default settings).

### 1 Press the power switch.

The camera turns on in the “still picture capture mode”.

### 2 Make sure of the subject and shooting information on the display.

The focus frame in the middle of the display indicates the zone of automatic focusing.



Focus frame

When the camera detects a person's face, the Face Detection function is activated and the face detection frame appears (p.69).

You can change the captured area by pressing the zoom button (p.73).

- Right (▲) Enlarges the subject.
- Left (◀) Widens the area that is captured by the camera.

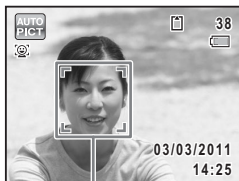

Face detection frame

**3**

### Press the shutter release button halfway.

The focus frame (or face detection frame) on the display turns green when the camera focuses on the subject at the correct distance.

**4**

### Press the shutter release button fully.

The picture is taken.

The flash discharges automatically depending on the light conditions. The captured image appears on the display (Instant Review: p.67) and is saved to the SD Memory Card or the built-in memory.



Press the Green button to switch to the  (Green) mode and let the camera set all the shooting functions automatically (p.72).

## Using the Shutter Release Button

The shutter release button works in a two-step action as follows.

### Press halfway

This refers to pressing the shutter release button gently to the first position. This locks the focus setting and the exposure. The green focus frame is displayed on the monitor when the shutter release button is pressed halfway and the subject is in focus. If the subject is out of focus, the white focus frame appears.

3

### Press fully

This refers to pressing the shutter release button all the way down to the fully depressed position. This takes a picture.

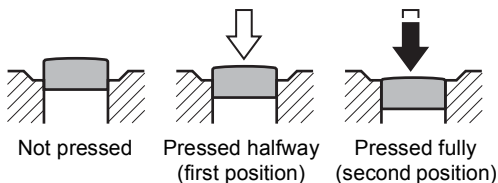

### Poor focusing conditions

The camera may not be able to focus under the following conditions. In these cases, lock the focus on an object the same distance away as the subject (by pressing and holding the shutter release button halfway), then aim the camera at your subject and press the shutter release button fully.

- Objects that lack contrast such as a blue sky or white wall
- Dark places or objects, or conditions that prevent light from being reflected back
- Horizontal lines or intricate patterns
- Fast moving objects
- When there is an object in the foreground and an object in the background in the captured area
- Strongly reflected light or strong backlighting (bright background)

## Instant Review and Blink Detection

Immediately after capturing an image, it appears on the screen display for 1 second (Instant Review). If the camera detects that the subject's eyes are closed while the Face Detection function (p.69) is activated, the message [Closed eyes have been detected] appears for 3 seconds (Blink Detection).



- When the Face Detection function does not work, Blink Detection also does not function. Even if the subjects' faces are detected, Blink Detection may not function depending on the condition of the detected faces.
- You can also disable the Blink Detection function (p.100).

## Setting the Shooting Mode

The Optio S1 has a variety of shooting modes that let you take pictures in different situations simply by choosing the appropriate mode for the particular situation from the Capture Mode Palette.

### 1 Press the four-way controller (▼) in mode.

The Capture Mode Palette appears.

### 2 Use the four-way controller (▲▼◀▶) to choose a shooting mode.

When an icon is selected in the Capture Mode Palette, the guide for the selected shooting mode appears.

























### 3 Press the OK button.

The shooting mode is fixed and the camera returns to capture status.







There are 23 shooting modes which can be selected from the Capture Mode Palette.

Shooting Mode	Description	Page
 Auto Picture	Automatically selects the best capture mode.	p.70
 Program	Used for basic shooting. Various functions can also be set with this mode.	p.71
 Blue Sky	Emphasizes saturation of the sky to produce a bright image.	—
 Landscape	For capturing landscape views. Enhances colors of sky and foliage.	—
 Flower	For images of flowers. The outline of the flower is softened.	—
 Sunset	For images of sunsets and warm lighting.	—
 Night Scene	For night time images. Use of a tripod or other support is suggested.	p.75
 Night Scene Portrait	For images of people at night. Use of a tripod or other support is advised.	p.75
 Portrait	For capturing portraits. Reproduces a healthy and bright skin tone.	p.76
 Natural Skin Tone	For images of people. Enhances skin tones while smoothing blemishes.	p.76
 Food	For images of food and prepared dishes. Enhances saturation and contrast.	—
 Digital SR	Higher sensitivity reduces blur.	p.75
 Kids	For capturing moving kids. Reproduces a healthy and bright skin tone.	p.77
 Pet	For capturing moving pets. Select the color according to the pet's coat.	p.78
 Sport	For a fast moving subject. Tracks the subject until the picture is taken.	p.79
 Surf & Snow	For bright images such as sand or snow. Accurately meters for bright scenes.	p.79
 Fireworks	For capturing fireworks. Use of a tripod or other support is suggested.	p.75
 Frame Composite	For capturing images with a frame.	p.80
 Party	For capturing images at parties or in dim light. Increases ISO and clarity.	p.81
 Candlelight	For capturing scenes in candlelight.	p.75
 Text	Captures text in an easy to read manner. Text contrast can be adjusted.	p.82

Shooting Mode	Description	Page
 Miniature Filter	For capturing an image where the subject looks like a miniature object.	p.83
<b>HDR</b> HDR Filter	For capturing an image with HDR-like effect.	p.83

\* In addition to the modes listed above,  (Green) mode (p.72) and Voice Recording (p.158) are also available.



- In shooting modes other than , ,  and , saturation, contrast, sharpness, white balance, etc. are set to the optimal settings for the selected mode.
- Some functions may not be available or may not work fully depending on the selected shooting mode. For details, refer to “Functions Available for Each Shooting Mode” (p.196).

## Using the Face Detection Function

With the Optio S1, the Face Detection function is available with all shooting modes.

When the camera detects a person's face in the image, the Face Detection function displays a yellow face detection frame around the face on the screen display, sets the focus (Face Detection AF) and compensates the exposure (Face Detection AE).

If the subject in the face detection frame moves, the frame also moves and changes its own size as it tracks the face.

The Face Detection function can detect up to 16 people's faces. If it detects multiple faces, the camera displays a yellow frame over the main face and white frame(s) over the other face(s).

The default setting is [On]. You can switch to the Smile Capture function that automatically releases the shutter when the subject smiles. Refer to “Switching the Face Detection Function” (p.100) for details.

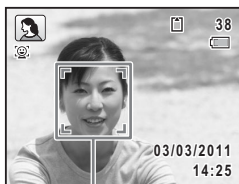

Face detection frame

When the multiple faces are detected



Main frame      White frame

## Taking Pictures Automatically (Auto Picture Mode)

In **AUTO PICT** (Auto Picture) mode, the camera automatically selects the most appropriate mode depending on the situations and subjects.

### 1 Press the four-way controller (▼) in **AUTO PICT** mode.

The Capture Mode Palette appears.

### 2 Use the four-way controller (▲▼◀▶) to select **AUTO PICT**.

### 3 Press the OK button.

The **AUTO PICT** mode is selected and the camera returns to capture status.

When the camera detects a person's face, the Face Detection function is activated and the face detection frame appears (p.69).



### 4 Press the shutter release button halfway.

The selected shooting mode is displayed on the top left of the screen.

Standard	Night Scene	Landscape
Portrait	Night Scene Portrait	Flower
Candlelight	Blue Sky	Portrait×Blue Sky
Portrait×Backlight	Sunset	Portrait×Sunset
Group Photograph	Text	

The focus frame on the display turns green when the camera focuses on the subject at the correct distance.

### 5 Press the shutter release button fully.

The picture is taken.





The following restrictions apply in **AUTO PICT** mode:

- [Face Detection] cannot be set to [Off].
- The focusing area setting is fixed at [ ] (Multiple).
- The (Flower) mode cannot be selected when using Digital Zoom or Intelligent Zoom.
- If the (Night Scene) mode is selected when the flash mode is set to (Auto) or (Auto + Red-eye), the flash mode automatically changes to (Flash Off).
- If the (Night Scene Portrait) mode is selected when the flash mode is set to (Auto), the flash mode automatically changes to (Flash On + Red-eye) when the camera detects a face and determines that the flash is needed.

## Taking Pictures in the Custom Settings (Program Mode)

In **P** (Program) mode, the camera automatically sets the shutter speed and aperture for taking still pictures. However, you can change the settings of some functions such as the flash mode and the number of recorded pixels.

### 1 Press the four-way controller (▼) in mode.

The Capture Mode Palette appears.

### 2 Use the four-way controller (▲▼◀▶) to select **P**.

### 3 Press the OK button.

The **P** mode is selected and the camera returns to capture status.

When the camera detects a person's face, the Face Detection function is activated and the face detection frame appears (p.69).



### 4 Change the settings as needed.

Refer to "Setting the Shooting Functions" (p.88 - p.108) for details on how to set the functions.

### 5 Press the shutter release button halfway.

The focus frame on the display turns green when the camera focuses on the subject at the correct distance.







## 6 Press the shutter release button fully.

The picture is taken.

### Taking Pictures in the Basic Mode (Green Mode)

In **●** (Green) mode, you can enjoy easy picture-taking using standard settings, regardless of the settings in the [  Rec. Mode ] menu.

The **●** mode settings are as shown below.

Flash Mode	 (Auto)	Highlight Correction	<input type="checkbox"/> (Off)
Drive Mode	<input type="checkbox"/> (Standard)	Shadow Correction	<input type="checkbox"/> (Off)
Focus Mode	<b>AF</b> (Standard)	Shake Reduction	<input checked="" type="checkbox"/> (On)
Information Display	Normal	Face Detection	On
Recorded Pixels	 (4288×3216)	Blink Detection	<input checked="" type="checkbox"/> (On)
White Balance	<b>AWB</b> (Auto)	Digital Zoom	<input checked="" type="checkbox"/> (On)
Focusing Area	 (Multiple)	Instant Review	<input checked="" type="checkbox"/> (On)
AE Metering	 (Multi-segment metering)	Sharpness	 (Normal)
Sensitivity	Auto	Saturation	 (Normal)
EV Compensation	±0.0	Contrast	 (Normal)
		Date Imprint	Off

## 1 Press the Green button in mode.

The camera switches to **●** mode.

**Press the Green button again to return to the status before **●** mode was selected.**

When the camera detects a person's face, the Face Detection function is activated and the face detection frame appears (p.69).



## 2 Press the shutter release button halfway.

The focus frame on the display turns green when the camera focuses on the subject at the correct distance.

## 3 Press the shutter release button fully.

The picture is taken.



- The **●** mode is available only when it is assigned to the Green button in [Green Button] of the [Rec. Mode] menu (p.107). By default, the **●** mode is assigned to the Green button.
- In **●** mode, you cannot change the information on the display by pressing the **OK/DISPLAY** button.
- If you press the **MENU** button in **●** mode, the [Setting] menu appears. The [Rec. Mode] and [Movie] menus cannot be displayed.
- When the camera is turned off in **●** mode, it turns on in **●** mode next time the power switch is pressed.

## Using the Zoom

You can use the zoom to change the captured area.

### 1 Press the zoom button in **●** mode.

Right (▲) Enlarges the subject.

Left (▲▲▲) Widens the area that is captured by the camera.

When you continue to press the button towards the right (▲), the camera automatically switches from optical zoom to Intelligent Zoom.

Once the button is released and pressed again, the camera switches to Digital Zoom.

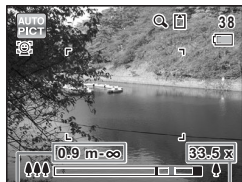

Focus range  
(during zooming only)

Zoom bar

Zoom ratio

The zoom bar is displayed as follows.

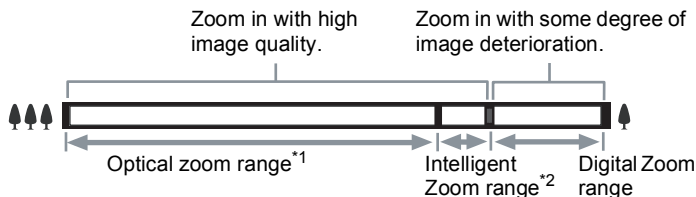

\*1 You can zoom in to a maximum of 5× optically.

\*2 The Intelligent Zoom range differs depending on the number of recorded pixels. See the following table.

## Recorded pixels and the maximum zoom ratio

Recorded Pixels	Intelligent Zoom	Digital Zoom
14M	Not Available (5× optical zoom only)	Equivalent to approx. 33.5×
10M 1080 / 10M 1635	Not Available (5× optical zoom only)	
7M	Approx. 7.0×	
2 M 1635	Approx. 11.2×	
640	Approx. 33.5× (Same as Digital Zoom)	

3

Taking Pictures



- It is recommended to use a tripod to prevent camera shake when taking pictures at high zoom.
- Pictures taken in the Digital Zoom range appear grainier than pictures taken in the optical zoom range.
- Intelligent Zoom is not available under the following conditions:
  - When the number of recorded pixels is set to 14M / 10M 1080 / 10M 1635 (5× optical zoom is available)
  - In (👤) (Digital SR) mode
  - When the sensitivity is set to 3200 or 6400
- The image enlarged using Intelligent Zoom may appear rough on the display. This does not affect the quality of the recorded image.
- Only Digital Zoom is available while recording a movie.
- The focus range is not displayed when the focus mode is set to PF/▲ or the shooting mode is set to 🌈 (Fireworks), or while recording a movie.

### To Set the Digital Zoom

The Digital Zoom is set to  (On) in the default setting. To take pictures using only the optical zoom and Intelligent Zoom, set the Digital Zoom to  (Off).

**1** Press the **MENU** button in **📷** mode.

The [📷 Rec. Mode] menu appears.

**2** Use the four-way controller (▲ ▼) to select [Digital Zoom].

### 3 Use the four-way controller (◀▶) to select or .

- Uses Digital Zoom
- Uses only optical zoom and Intelligent Zoom

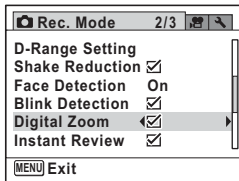

### 4 Press the MENU button.

The camera returns to capture status.

Saving the Digital Zoom Function setting p.113

## Taking Pictures of Dark Scenes (Night Scene/Night Scene Portrait/Digital SR/Fireworks/Candlelight Mode)

You can choose an appropriate shooting mode for taking pictures of dark scenes, such as nightscapes.

Night Scene	For night time images. Use of a tripod or other support is suggested.
Night Scene Portrait	For images of people at night. Use of a tripod or other support is advised. If the Face Detection function is activated when the flash mode is set to  (Auto), the flash mode automatically changes to  (Flash On + Red-eye).
Digital SR	Higher sensitivity reduces blur. The sensitivity is automatically set to [Auto] and the number of recorded pixels is fixed at  (2592×1944).
Fireworks	For capturing fireworks. Use of a tripod or other support is suggested. The shutter speed is fixed at 4 sec. and the sensitivity is fixed at the minimum value.
Candlelight	For capturing scenes in candlelight.

### 1 Press the four-way controller (▼) in mode.

The Capture Mode Palette appears.

### 2 Use the four-way controller (▲▼◀▶) to select , , , or .

### 3 Press the OK button.

The , , , or mode is selected and the camera returns to capture status.

When the camera detects a person's face, the Face Detection function is activated and the face detection frame appears (p.69).

### 4 Press the shutter release button halfway.

The focus frame on the display turns green when the camera focuses on the subject at the correct distance.

### 5 Press the shutter release button fully.

The picture is taken.



- The shutter speed tends to be slower when taking pictures of dark scenes.
- To prevent camera shake, set [Shake Reduction] (p.102) to  (On), or use a tripod and/or the self-timer function (p.84).

## Taking Pictures of People (Portrait/Natural Skin Tone Mode)

The (Portrait) and (Natural Skin Tone) modes are suitable for taking pictures of people. [Face Detection] (p.69) is automatically set to [On] for each shooting mode, making it easier to emphasize the subject's face when taking pictures.



Portrait	For capturing portraits. Reproduces a healthy and bright skin tone.
Natural Skin Tone	For images of people. Enhances skin tones while smoothing blemishes.

### 1 Press the four-way controller (▼) in mode.

The Capture Mode Palette appears.

### 2 Use the four-way controller (▲ ▼ ◀ ▶) to select or .

### 3 Press the OK button.

The  or  mode is selected and the camera returns to capture status. When the camera detects a person's face, the Face Detection function is activated and the face detection frame appears (p.69).



### 4 Press the shutter release button halfway.

The focus frame on the display turns green when the camera focuses on the subject at the correct distance.

### 5 Press the shutter release button fully.

The picture is taken.

## Taking Pictures of Children (Kids Mode)

The  (Kids) mode is suitable for taking pictures of moving children. It also reproduces a healthy and bright skin tone. [Face Detection] (p.69) is automatically set to [On] for this mode, making it easier to emphasize the subject's face when taking pictures.

### 1 Press the four-way controller (▼) in mode.

The Capture Mode Palette appears.

### 2 Use the four-way controller (▲▼◀▶) to select .

### 3 Press the OK button.

The  mode is selected and the camera returns to capture status. The camera tracks the subject and continues to focus on it.

When the camera detects a person's face, the Face Detection function is activated and the face detection frame appears (p.69).



### 4 Press the shutter release button fully.

The picture is taken.



When [Focusing Area] (p.91) is set to [ ] (Multiple) or [ ] (Spot), focus can be locked by pressing the shutter release button halfway.

## Taking Pictures of Your Pet (Pet Mode)

Use the (Pet) mode to keep your moving pet in focus and capture the color of your pet's coat when you take a picture. Choose the appropriate icon depending on what color your pet is (closer to black or white or in between).

3

Taking Pictures

### 1 Press the four-way controller (▼) in mode.

The Capture Mode Palette appears.

### 2 Use the four-way controller (▲▼◀▶) to select .

### 3 Press the OK button.

The mode selection screen appears.

### 4 Use the four-way controller (▲▼) to select , , , , or .

There are two types of icons: a dog and cat icon. Your choice of dog or cat icon does not affect the resulting picture, so you can choose whichever you prefer.

Choose an icon (white, gray, or black) whose tone best matches your pet's coat or fur.



### 5 Press the OK button.

The selected icon appears and the camera returns to capture status. The camera tracks the subject and continues to focus on it.

When the camera detects a person's face, the Face Detection function is activated and the face detection frame appears (p.69).



### 6 Press the shutter release button fully.

The picture is taken.





When [Focusing Area] (p.91) is set to [ ] (Multiple) or [ ] (Spot), focus can be locked by pressing the shutter release button halfway.

## Taking Pictures of Sports and Leisure Activities (Sport/Surf & Snow Mode)

Sport	For a fast moving subject. Tracks the subject until the picture is taken.
Surf & Snow	For bright images such as sand or snow. Accurately meters for bright scenes.

### 1 Press the four-way controller (▼) in mode.

The Capture Mode Palette appears.

### 2 Use the four-way controller (▲▼◀▶) to select or .

### 3 Press the OK button.

The or mode is selected and the camera returns to capture status. In mode, the camera tracks the subject and continues to focus on it.

When the camera detects a person's face, the Face Detection function is activated and the face detection frame appears (p.69).

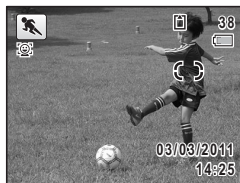

### 4 Press the shutter release button halfway.

The focus frame on the display turns green when the camera focuses on the subject at the correct distance.

### 5 Press the shutter release button fully.



The picture is taken.



When [Focusing Area] (p.91) is set to [ ] (Multiple) or [ ] (Spot) in mode, focus can be locked by pressing the shutter release button halfway.

## Framing Your Pictures (Frame Composite Mode)

In  (Frame Composite) mode, you can take pictures using the frames stored in the camera.

- 1 Press the four-way controller (▼) in  mode.**  
The Capture Mode Palette appears.
- 2 Use the four-way controller (▲▼◀▶) to select .**
- 3 Press the OK button.**  
The 9-frame display of the frame selection screen appears.
- 4 Use the four-way controller (▲▼◀▶) to choose the frame you want to use.**

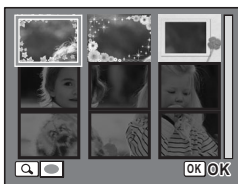

- 5 Press the zoom button towards the right (Q).**  
The selected frame appears in single-image display.  
You can choose another frame using either of the following operations.

Four-way controller (◀▶)	Press to choose a different frame.
Zoom button towards the left (⊞)	Returns to the 9-frame display of the frame selection screen, and then lets you choose a different frame in the same way as Step 4.

- 6 Press the OK button.**  
The framed image appears on the display.  
When the camera detects a person's face, the Face Detection function is activated and the face detection frame appears (p.69).



- 7 Press the shutter release button halfway.**  
The focus frame on the display turns green when the camera focuses on the subject at the correct distance.

## 8

### Press the shutter release button fully.

The picture is taken.



- The number of recorded pixels is fixed at **3M** (2048×1536).
- Frames cannot be added to movies.
- By default, three frames are built-in to the camera. These frames are not deleted even if the built-in memory is formatted.
- The CD-ROM (S-SW116) supplied with the camera contains 90 optional frames. To save the frames into the built-in memory, copy the files from the CD-ROM (p.147).

Adding a Frame to a captured image p.145

## Taking Pictures Indoors (Party Mode)

The (Party) mode is suitable for taking pictures indoors, such as snapshots at parties.

### 1

#### Press the four-way controller () in mode.

The Capture Mode Palette appears.

### 2

#### Use the four-way controller ( ) to select .

### 3

#### Press the OK button.

The mode is selected and the camera returns to capture status. When the camera detects a person's face, the Face Detection function is activated and the face detection frame appears (p.69).

### 4

#### Press the shutter release button halfway.

The focus frame on the display turns green when the camera focuses on the subject at the correct distance.





### 5

#### Press the shutter release button fully.

The picture is taken.

## Taking Pictures of Text (Text Mode)

The  (Text) mode allows you to take clear pictures of written text. This is convenient for capturing a digital copy of an important document or enhancing the legibility of small print.

 Color	Maintains the original color of the text.
 Neg. Color	Reverses the color of the text.
 B & W	Turns the color of the text into black and white.
 Neg. B & W	Turns the color of the text into reversed black and white.

3

### 1 Press the four-way controller (▼) in mode.

The Capture Mode Palette appears.

### 2 Use the four-way controller (▲▼◀▶) to select .

### 3 Press the OK button.

The  mode selection screen appears.

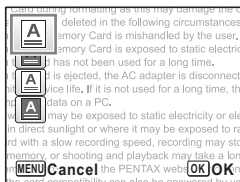

### 4 Use the four-way controller (▲▼) to select , , or .

### 5 Press the OK button.

The selected icon appears and the camera returns to capture status.

When the camera detects a person's face, the Face Detection function is activated and the face detection frame appears (p.69).

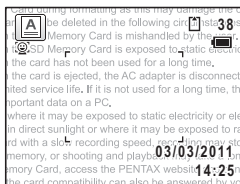

### 6 Press the shutter release button halfway.

The focus frame on the display turns green when the camera focuses on the subject at the correct distance.



### 7 Press the shutter release button fully.



The picture is taken.

## Taking Pictures Using the Miniature/HDR Filter

In  (Miniature)/**HDR** (HDR) Filter mode, you can take impressive pictures using the filter.

 Miniature Filter	For capturing an image where the subject looks like a miniature object. The number of recorded pixels is fixed at <b>5M</b> (2592×1944).
<b>HDR</b> HDR Filter	For capturing an image with HDR-like effect.

- 1 Press the four-way controller (▼) in  mode.**  
The Capture Mode Palette appears.
- 2 Use the four-way controller (▲▼◀▶) to select  or HDR.**
- 3 Press the OK button.**  
When the  mode is selected, the screen for selecting the area to be blurred is displayed.  
When the **HDR** mode is selected, proceed to Step 6.
- 4 Use the four-way controller (◀▶) to select an option.**

	Focuses on the bottom of the image and blurs the top.
	Focuses on the center of the image and blurs the top and bottom.
	Focuses on the top of the image and blurs the bottom.

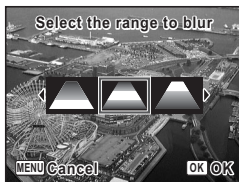

- 5 Press the OK button.**  
The  or **HDR** mode is selected and the camera returns to capture status.  
When the camera detects a person's face, the Face Detection function is activated and the face detection frame appears (p.69).



- 6 Press the shutter release button halfway.**  
The focus frame on the display turns green when the camera focuses on the subject at the correct distance.

## 7 Press the shutter release button fully.



The picture is taken.

Processing the captured images by using the Miniature/HDR filter  p.138

## Using the Camera's Self-timer

In Self-timer mode, the picture is taken ten seconds or two seconds after the shutter release button is pressed.

Stabilize the camera with a tripod or other support when taking a picture using the self-timer.

 Self-timer	Use this mode when you want to be included in a group picture. The picture is taken approximately ten seconds after the shutter release button is pressed.
 2 sec. Self-timer	Use this mode to avoid camera shake. The picture is taken approximately two seconds after the shutter release button is pressed.

## 1 Press the four-way controller (▲) in mode.

The [Drive Mode] screen appears.

## 2 Use the four-way controller (◀▶) to select and press the four-way controller (▼).

## 3 Use the four-way controller (◀▶) to select or and press the OK button.

The camera is ready to take the picture using the self-timer.

When the camera detects a person's face, the Face Detection function is activated and the face detection frame appears (p.69).



## 4 Press the shutter release button halfway.

The focus frame on the display turns green when the camera focuses on the subject at the correct distance.

## 5 Press the shutter release button fully.

The picture is taken ten seconds or two seconds later.



Focusing may be compromised if you move the camera while the self-timer lamp is blinking when taking still pictures.



- For movies, recording will start ten seconds or two seconds after the button is pressed.
- Press the shutter release button halfway while the self-timer is running to stop the countdown and press fully to restart the countdown.
- cannot be selected while the (Green) mode settings remain at default. However, it can be selected if you select in another shooting mode first, and then switch the shooting mode to .

## Taking a Series of Pictures (Continuous Shooting/Burst Shooting Mode)

In these modes, pictures are taken continuously as long as the shutter release button is pressed.

Continuous Shooting	Each time an image is taken, it is saved in the memory before the next image is taken. The higher the image quality, the longer the interval between shots. You can continue shooting until the capacity of the SD Memory Card or the built-in memory is full.
Burst Shooting	The number of recorded pixels is fixed at <b>5M</b> (2592×1944) and pictures are taken consecutively.



The number of pictures that can be taken consecutively and the frame rate per second vary depending on the shooting condition.

**1**

**Press the four-way controller (▲) in mode.**

The [Drive Mode] screen appears.

**2**

**Use the four-way controller (◀▶) to select or and press the OK button.**

The camera is ready to take a series of pictures.



### 3 Press the shutter release button halfway.

The focus frame on the display turns green when the camera focuses on the subject at the correct distance.

### 4 Press the shutter release button fully.

Pictures are taken continuously as long as you keep the shutter release button pressed.



- The flash does not discharge in and modes.
- and cannot be selected in (Green), (Fireworks), (Frame Composite), (Miniature Filter) or **HDR** (HDR Filter) mode, or when recording a movie.
- Digital Zoom and Intelligent Zoom are not available in mode.



- The focus, exposure and white balance are locked with the first shot.
- When [Face Detection] is set to [On] (p.69), it works only for the first shot.
- The Blink Detection function works only for the last shot.
- In (Auto Picture) mode, pictures are taken consecutively in the shooting mode selected for the first shot.

## Taking Pictures Using the Remote Control Unit (Optional)

You can use the optional remote control (p.208) to take pictures while you are away from the camera.

Stabilize the camera with a tripod or other support when taking a picture using the remote control unit.

Remote Control	The self-timer lamp blinks quickly and the picture is taken approximately three seconds after the shutter release button on the remote control unit is pressed.
0-sec Remote Control	The picture is taken immediately after the shutter release button on the remote control unit is pressed.

### 1 Press the four-way controller (▲) in mode.

The [Drive Mode] screen appears.

### 2 Use the four-way controller (◀▶) to select and press the four-way controller (▼).



### 3 Use the four-way controller (◀▶) to select or and press the OK button.



The self-timer lamp begins to blink slowly and the camera is ready to take a picture with the remote control.

When the camera detects a person's face, the Face Detection function is activated and the face detection frame appears (p.69).

### 4 Point the remote control at the remote control receiver and press the shutter release button on the remote control.

The focus frame turns green when the subject is in focus and the camera takes a picture.



- The operating range is approx. 4 m (13 ft.) from the front of the camera when using the remote control unit.
- The camera takes a picture even if the subject is out of focus.
- Press the shutter release button on the camera halfway while the self-timer is running to stop the countdown, and press the shutter release button on the remote control again to restart the countdown.
- You cannot take a picture using the remote control unit in  (Green) mode.
- The self-timer lamp does not blink in  (Pet) mode.
- When using the REMOTE CONTROL WATERPROOF O-RC1, you can record a movie by pressing the **Fn** button on the remote control or the  button on the camera.
- You can also zoom in and out using the Zoom button on the remote control.

# Setting the Shooting Functions

## Selecting the Flash Mode

Auto	The flash discharges automatically depending on the light conditions. If the Face Detection function is activated, the flash mode is automatically set to .
Flash Off	The flash does not discharge, regardless of the brightness. Use this mode to take pictures where flash photography is prohibited.
Flash On	The flash discharges regardless of the brightness.
Auto + Red-eye	This mode reduces the phenomenon of red eyes caused by the light from the flash being reflected in the subject's eyes. The flash discharges automatically. A pre-flash discharges before the main flash.
Flash On + Red-eye	This mode reduces the phenomenon of red eyes caused by the light from the flash being reflected in the subject's eyes. The flash discharges regardless of the light conditions. A pre-flash discharges before the main flash.



- The flash mode is fixed at in the following situations:
  - When (Fireworks) is selected as the shooting mode
  - When recording a movie
  - When (Continuous Shooting) or (Burst Shooting) is selected as the drive mode
  - When (Infinity) is selected as the focus mode
- In (Green) mode, you can only select or .
- In (Night Scene) mode, you cannot select and .



Using the flash when capturing images at a close distance may cause the unevenness of the light distribution.

### 1 Press the four-way controller (◀) in mode.

The [Flash Mode] screen appears.

The flash mode changes each time the button is pressed. You can also change the setting using the four-way controller (▲▼).



## 2 Press the OK button.

The setting is saved and the camera returns to capture status.

### About the red-eye phenomenon

Taking pictures using the flash may cause the subject's eyes to appear red in the resulting picture. This phenomenon occurs when the light from the flash is reflected in the subject's eyes. It can be reduced by illuminating the area around the subject or moving closer to the subject and zooming out to a wider angle. Setting the flash mode to  $\text{A}$  or  $\text{4}$  is also an effective way of reducing red eyes. If the subject's eyes appear red despite such precautions, they can be corrected by the red-eye compensation function (p.144).

Saving the Flash Mode setting  $\text{p.113}$

## Selecting the Focus Mode

<b>AF</b> Standard	This mode is used when the distance to the subject is 40 cm (16 in.) or more. The camera is focused on the subject in the autofocus area when the shutter release button is pressed halfway. When the subject is close to the camera, the Auto-Macro function is activated and $\text{M}$ appears on the display.
$\text{M}$ Macro	This mode is used when the distance to the subject is approx. 10 cm to 50 cm (4 in. to 20 in.). The camera is focused on the subject in the autofocus area when the shutter release button is pressed halfway.
$\text{SM}$ Super Macro	This mode is used when the distance to the subject is approx. 5 cm to 30 cm (2 in. to 12 in.). The camera is focused on the subject in the autofocus area when the shutter release button is pressed halfway.
<b>PF</b> Pan Focus	This mode is used when you ask someone to take pictures for you, or when taking pictures of the scenery through the window of a car or train. The entire picture, from the front to the back, is focused.
$\text{A}$ Infinity	This mode is used for taking distant objects. The flash is set to $\text{O}$ (Flash Off).
<b>MF</b> Manual Focus	This mode lets you adjust the focus manually.

## 1 Press the four-way controller (►) in $\text{CAM}$ mode.

The [Focus Mode] screen appears.

The focus mode changes each time the button is pressed. You can also change the setting using the four-way controller ( $\blacktriangle$ ▼).

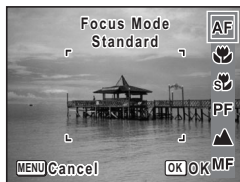

## 2 Press the OK button.

The setting is saved and the camera returns to capture status.



- In **AF** (Green) mode, you can only select **AF**, **S** or **PF**.
- The focus mode is fixed at **MF** in **Fireworks** mode.
- When shooting with **S** selected, if the subject is further than 50 cm away, the camera automatically focuses to  $\infty$  (Infinity). By pressing the shutter release button fully, you can also take a picture even when the focus is not set.

Saving the Focus Mode setting p.113

### To Set the Focus Manually (Manual Focus)

#### 1 Press the four-way controller (▶) in **AF** mode.

The [Focus Mode] screen appears.

#### 2 Press the four-way controller (▶) to select **MF**.

#### 3 Press the OK button.

The central portion of the image is magnified to full screen on the display.

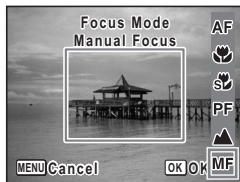

#### 4 Use the four-way controller (▲▼) to adjust the focus.

The **MF** indicator appears on the display to indicate the approximate distance to the subject. Adjust the focus using the indicator as a guide.

- ▲ for distant focus
- ▼ for closer focus

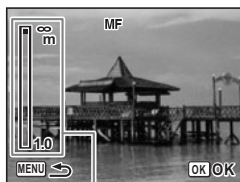

**MF** indicator

## 5 Press the OK button.

The focus is fixed and the camera returns to capture status. After the focus is fixed, you can press the four-way controller (▶) again to display the **MF** indicator and readjust the focus.



The shooting mode and drive mode cannot be changed while the **MF** indicator is displayed.



To switch from **MF** to another focus mode, press the four-way controller (▶) while the **MF** indicator is displayed.

## To Set the Focusing Area

You can change the autofocus area (Focusing Area).

[ ] Multiple	Normal autofocus area
[ ] Spot	The autofocus area becomes smaller.
[ ] Automatic Tracking AF	Keeps moving subjects in focus.

## 1 Press the MENU button in mode.

The [ Rec. Mode] menu appears.

## 2 Use the four-way controller (▲▼) to select [Focusing Area].

## 3 Press the four-way controller (▶).

A pull-down menu appears.

## 4 Use the four-way controller (▲▼) to change the focusing area setting.

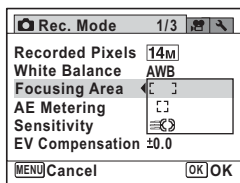

## 5 Press the OK button.

The setting is saved.

## 6 Press the MENU button.

The camera returns to capture status.



- In (Green) and (Auto Picture) modes, the focusing area is fixed at .
- If you change the [Focusing Area] setting frequently, you can save time by assigning it to the Green button (p.107).

## Selecting the Number of Recorded Pixels

3

You can choose from six recorded pixels settings for still pictures. The larger the number of recorded pixels, the clearer the details will appear when you print your picture. As the quality of the printed picture also depends on the image quality, exposure control, resolution of the printer, and other factors, you do not need to select more than the required number of recorded pixels. The more pixels there are, the larger the picture and the bigger the file size.

Refer to the following table for the appropriate settings according to expected usage.

Recorded Pixels	Expected Usage
4288×3216	↑ Clearer For printing high quality photos or A4-size or larger prints, or editing images on a computer.
3216×3216	
4224×2376	For making postcard-size prints.
3072×2304	
1920×1080	For posting on a website or attaching to e-mail.
640×480	

The default setting is .



If you select or , the aspect ratio of the image is 16:9 and the monitor display for recording and playback is as shown on the right.



## 1 Press the MENU button in mode.

The [ Rec. Mode] menu appears.

## 2 Use the four-way controller ( ) to select [Recorded Pixels].

## 3 Press the four-way controller () .

A pull-down menu appears.

## 4 Use the four-way controller ( ) to change the number of recorded pixels.

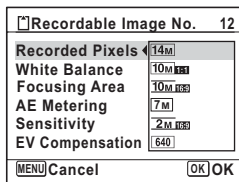





## 5 Press the OK button.

The setting is saved.

## 6 Press the MENU button.

The camera returns to capture status.



- The number of recorded pixels in  (Green) mode is fixed at **14M**.
- The number of recorded pixels in  (Frame Composite) mode is fixed at **3M**.
- The number of recorded pixels in  (Miniature Filter),  (Digital SR), or  (Burst Shooting) mode is fixed at **5M**.
- If you change the [Recorded Pixels] setting frequently, you can save time by assigning it to the Green button (p.107).

## Compensating for Exposure (EV Compensation)

You can adjust the overall brightness of the picture.

Use this function to take pictures that are intentionally overexposed or underexposed.

### 1 Press the **MENU** button in **📷** mode.

The [📷 Rec. Mode] menu appears.

### 2 Use the four-way controller (▲▼) to select [EV Compensation].

### 3 Use the four-way controller (◀▶) to select the EV value.

To brighten, select a positive (+) value. To darken, select a negative (-) value.

You can choose the EV setting in the range of -2.0 EV to +2.0 EV in 1/3 EV steps.

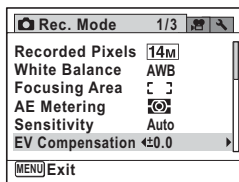

### 4 Press the **MENU** button.

The camera returns to capture status.



- When the histogram is displayed in still picture capture mode/playback mode, you can check the exposure (p.26).
- The EV compensation function cannot be used in **🟢** (Green) or **AUTO PICT** (Auto Picture) mode.
- If you change the [EV Compensation] setting frequently, you can save time by assigning it to the Green button (p.107).

Saving the EV Compensation value setting p.113



## Correcting the Brightness (D-Range Setting)

Expands the dynamic range and enables a more ample gradation expression, and reduces the occurrence of overexposed and underexposed areas. Highlight Correction adjusts the overexposed areas and Shadow Correction adjusts the underexposed areas.

### 1 Press the **MENU** button in **📷** mode.

The [📷 Rec. Mode] menu appears.

### 2 Use the four-way controller (▲▼) to select [**D-Range Setting**].

### 3 Press the four-way controller (▶) .

The [D-Range Setting] screen appears.

### 4 Use the four-way controller (▲▼) to select [**Highlight Correction**] or [**Shadow Correction**].

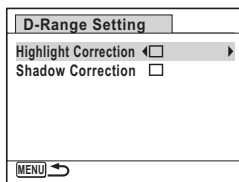



### 5 Use the four-way controller (◀▶) to select (On) or (Off).

### 6 Press the **MENU** button twice.

The camera returns to capture status.

The D-Range Setting icon appears on the display.





	When [Highlight Correction] is set to <input checked="" type="checkbox"/>
	When [Shadow Correction] is set to <input checked="" type="checkbox"/>
	When [Highlight Correction] and [Shadow Correction] are both set to <input checked="" type="checkbox"/>



- When [Highlight Correction] is set to  , the minimum sensitivity is ISO 125.
- If you change the [Highlight Correction] or [Shadow Correction] setting frequently, you can save time by assigning it to the Green button (p.107).

## Adjusting the White Balance

You can take pictures in natural colors by adjusting the white balance according to the light conditions at the time of shooting.

<b>AWB</b> Auto	The camera adjusts the white balance automatically.
 Daylight	Use this mode when taking pictures outside in sunlight.
 Shade	Use this mode when taking pictures outside in the shade.
 Tungsten Light	Use this mode when taking pictures under electric or other tungsten light.
 Fluores. Light	Use this mode when taking pictures under fluorescent light.
 Manual	Use this mode when adjusting the white balance manually.

3



- Set another white balance setting if you are not satisfied with the color balance of pictures taken with the [White Balance] set to **AWB**.
- Depending on the selected shooting mode, the white balance setting may not be changed. Refer to “Functions Available for Each Shooting Mode” (p.196) for details.

### 1 Press the **MENU** button in mode.



The [ Rec. Mode] menu appears.

### 2 Use the four-way controller ( ) to select [**White Balance**].

### 3 Press the four-way controller ().

The [White Balance] screen appears.

### 4 Use the four-way controller ( ) to change the setting.

You can check the result of selected white balance setting on the preview image each time you press the four-way controller ( ).

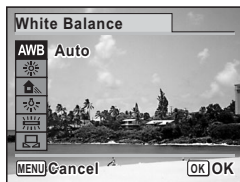

### 5 Press the **OK** button.

The setting is saved.

## 6 Press the MENU button.

The camera returns to capture status.



If you change the [White Balance] setting frequently, you can save time by assigning it to the Green button (p.107).

Saving the White Balance setting p.113

### To Set the White Balance Manually

Have a blank sheet of white paper or similar material ready.

**1** In the [White Balance] screen, use the four-way controller (▲▼) to select (Manual).

**2** Point the camera at the blank sheet of paper or other material so that it fills the frame displayed in the center of the screen.

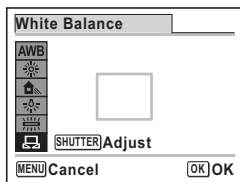

**3** Press the shutter release button fully.

The white balance is automatically adjusted.

**4** Press the OK button.



The setting is saved and the [ Rec. Mode] menu reappears.

**5** Press the MENU button.

The camera returns to capture status.

## Setting the AE Metering

You can set the area of the screen where the brightness is metered to determine the exposure.

 Multi-segment metering	The camera divides the image into 256 areas, meters the brightness and determines the exposure.
 Center-weighted metering	The camera takes a reading of the overall brightness of the picture with the center of the image having more influence on the exposure.
 Spot AE metering	The camera determines the exposure by metering the brightness only at the center of the image.

3

### 1 Press the MENU button in mode.

The [ Rec. Mode] menu appears.

### 2 Use the four-way controller (▲ ▼) to select [AE Metering].

### 3 Press the four-way controller (▶).

A pull-down menu appears.

### 4 Use the four-way controller (▲ ▼) to select the AE Metering setting.

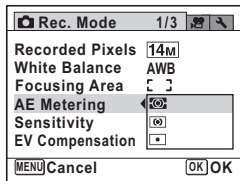

### 5 Press the OK button.

The setting is saved.

### 6 Press the MENU button.

The camera returns to capture status.



- When the shutter release button is pressed halfway, the brightness is metered and the exposure is determined.
- When the subject is outside the focusing area and you want to use  (Spot AE metering), aim the camera at the subject and press the shutter release button halfway to lock the exposure, then compose your picture again and press the shutter release button fully.
- Depending on the selected shooting mode, the AE metering setting may not be changed. Refer to "Functions Available for Each Shooting Mode" (p.196) for details.
- If you change the [AE Metering] setting frequently, you can save time by assigning it to the Green button (p.107).

Saving the AE Metering setting  p.113

## Setting the Sensitivity

You can select the sensitivity to suit the brightness of the surroundings.

Auto	The sensitivity is automatically adjusted by the camera. (Sensitivity 64 - 800)
64	 <p>The lower the sensitivity, the less noise that affects the image. The shutter speed will be slower in low light conditions.</p> <p>Higher sensitivity settings use faster shutter speeds in low light conditions to reduce camera shake, but the image may be affected by noise.</p>
100	
200	
400	
800	
1600	
3200	
6400	

### 1 Press the MENU button in mode.

The [ Rec. Mode] menu appears.

### 2 Use the four-way controller ( ) to select [Sensitivity].

### 3 Press the four-way controller ().

A pull-down menu appears.

#### 4 Use the four-way controller (▲▼) to change the sensitivity.

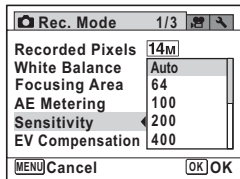

#### 5 Press the OK button.

The setting is saved.

#### 6 Press the MENU button.

The camera returns to capture status.



- When the sensitivity is set to 3200 or 6400, the number of recorded pixels is fixed at [5M] (2592×1944).
- In (Green) mode or when recording a movie, only [Auto] (sensitivity 64 - 800) is available.
- In (Digital SR) mode, only [Auto] (sensitivity 64 - 6400) is available.
- In (Fireworks) mode, the sensitivity is fixed at the minimum value.
- If you change the [Sensitivity] setting frequently, you can save time by assigning it to the Green button (p.107).

Saving the Sensitivity setting p.113

## Switching the Face Detection Function

The S1 comes with a Face Detection function that spots the faces in your shot and automatically adjusts the focus and exposure for the faces. It will automatically release the shutter when people are smiling, or if anyone blinked, it will tell you that so you can take the shot again until it is perfect. The default setting is [On] for [Face Detection] and  (On) for [Blink Detection].

#### 1 Press the MENU button in mode.

The [ Rec. Mode] menu appears.

#### 2 Use the four-way controller (▲▼) to select [Face Detection].

### 3 Press the four-way controller (▶).

A pull-down menu appears.

### 4 Use the four-way controller (▲▼) to select an option.

On	The camera detects a person's face.
Smile	The camera automatically release the shutter when your subject smiles.
Off	The camera does not detect a person's face.

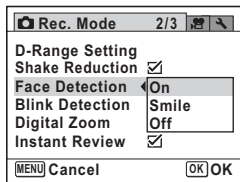

### 5 Press the OK button.

The setting is saved.

### 6 To set the Blink Detection function, press the four-way controller (▼) to select [Blink Detection].

### 7 Use the four-way controller (◀▶) to select or .

- Blink Detection function works.
- Blink Detection function does not work.

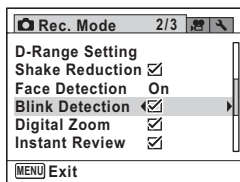

### 8 Press the MENU button.

The camera returns to capture status.

The Face Detection icon appears on the display.

	When [Face Detection] is set to [On]
	When [Face Detection] is set to [Smile]

Blink Detection p.67



- Face Detection AF and AE may not work if the subject is wearing sunglasses, has part of their face covered or is not looking toward the camera.
- If the camera cannot detect the subject's face, the camera focuses using the setting currently selected in [Focusing Area].
- When [Face Detection] is set to [Smile], the shutter may not be released automatically because the Smile Capture function may not work in some situations, such as when the detected face is too small. If this happens, press the shutter release button to release the shutter.
- [Face Detection] cannot be set to [Off] in (Auto Picture), (Portrait), (Night Scene Portrait), (Natural Skin Tone) or (Kids) mode.
- [Face Detection] is automatically set to [On] in (Green), (Auto Picture), (Portrait), (Night Scene Portrait), (Natural Skin Tone) or (Kids) mode. When switching to another mode from one of these modes, the Face Detection setting returns to the previous setting.
- For movies, the Face Detection function is activated before recording starts. The face detection frame is not displayed while recording a movie.

## Setting the Shake Reduction Function

The camera automatically corrects camera shake when taking still pictures. The default setting is  (On).



Use the Movie SR function (p.112) to correct camera shake when recording a movie.

### 1

**Press the MENU button in mode.**

The [ Rec. Mode] menu appears.

### 2

**Use the four-way controller ( ) to select [Shake Reduction].**

### 3

**Use the four-way controller ( ) to select  or .**

- Corrects camera shake.
- Does not correct camera shake.

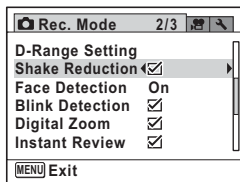



## 4 Press the MENU button.

The camera returns to capture status.

One of the following icons appears on the display.

	When [Shake Reduction] is set to <input checked="" type="checkbox"/>
	When [Shake Reduction] is set to <input type="checkbox"/> (Off) (If the camera shake is likely to occur,  is indicated when the shutter button is pressed halfway.)



The Shake Reduction function does not work in the following situations:

- When (Fireworks) is selected as the shooting mode
- When recording a movie
- When (Self-timer) is selected as the drive mode
- When the flash discharges
- During Voice Recording

## Setting the Instant Review

Use this setting to specify whether or not an Instant Review is displayed immediately after each image is taken. The default setting is  (On).

### 1 Press the MENU button in mode.

The [ Rec. Mode] menu appears.

### 2 Use the four-way controller ( ) to select [Instant Review].

### 3 Use the four-way controller ( ) to select or .

- Instant Review is displayed.
- Instant Review is not displayed.

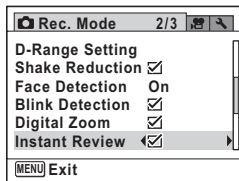

### 4 Press the MENU button.

The camera returns to capture status.

Instant Review p.67



If the Blink Detection function works when shooting, the message [Closed eyes have been detected] appears for 3 seconds during Instant Review.

## Setting the Image Sharpness (Sharpness)



You can give the image sharp or soft outlines.

### 1 Press the MENU button in mode.

The [ Rec. Mode] menu appears.

### 2 Use the four-way controller (▲▼) to select [Sharpness].

### 3 Use the four-way controller (◀▶) to change the sharpness level.

-  Soft
-  Normal
-  Sharp

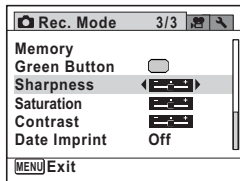

### 4 Press the MENU button.

The camera returns to capture status.



If you change the [Sharpness] setting frequently, you can save time by assigning it to the Green button (p.107).

## Setting the Color Saturation (Saturation)

You can set the color saturation.

- 1 Press the MENU button in  mode.**

The [ Rec. Mode] menu appears.

- 2 Use the four-way controller ( ) to select [Saturation].**

- 3 Use the four-way controller ( ) to change the saturation level.**

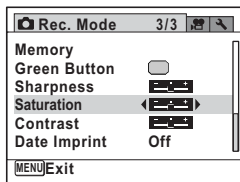
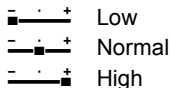

- 4 Press the MENU button.**

The camera returns to capture status.



If you change the [Saturation] setting frequently, you can save time by assigning it to the Green button (p.107).



## Setting the Image Contrast (Contrast)

You can set the image contrast level.

- 1 Press the MENU button in  mode.**

The [ Rec. Mode] menu appears.

- 2 Use the four-way controller ( ) to select [Contrast].**

- 3 Use the four-way controller ( ) to change the contrast level.**

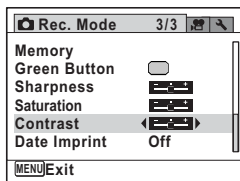
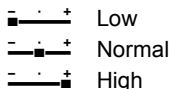

## 4 Press the MENU button.

The camera returns to capture status.



If you change the [Contrast] setting frequently, you can save time by assigning it to the Green button (p.107).

## Setting the Date Imprint Function

You can choose whether to imprint the date and/or time when taking still pictures.

3

Taking Pictures

### 1 Press the MENU button in mode.

The [ Rec. Mode] menu appears.

### 2 Use the four-way controller (▲▼) to select [Date Imprint].

### 3 Press the four-way controller (▶).

A pull-down menu appears.

### 4 Use the four-way controller (▲▼) to select the Date Imprint details.

Choose from [Date], [Date & Time], [Time] or [Off].

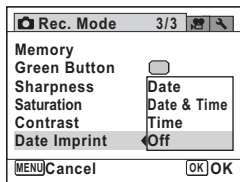

### 5 Press the OK button.

The setting is saved.

### 6 Press the MENU button.

The camera returns to capture status.



- The date and/or time imprinted cannot be deleted.
- Note that if the printer or the image editing software is set to print the date and the images to be printed already have the date and/or time imprinted, the imprinted dates and/or times may overlap.



- **DATE** appears on the display in mode when [Date Imprint] is set.
- The date and/or time are imprinted on the picture in the format set in the [Date Adjustment] screen (p.46).

## Calling Up a Specific Function

You can assign a function to the Green button and recall it quickly by simply pressing the Green button. This is useful to save time to get to the frequently used function.

The following functions can be assigned to the Green button:

- (Green) Mode
- Recorded Pixels
- White Balance
- Focusing Area
- AE Metering
- Sensitivity
- EV Compensation
- Highlight Correction
- Shadow Correction
- Sharpness
- Saturation
- Contrast
- Voice Recording



- The Green button setting can be returned to its default value by selecting [Reset] on the [ Setting] menu.
- The functions other than the (Green) mode and Voice Recording can be set in the usual manner on the [ Rec. Mode] menu.
- Although you can approach a function by assigning it to the Green button or selecting it from the [ Rec. Mode] menu, you cannot save different settings for each case.

## To Assign a Function to the Green Button

- 1 Press the MENU button in mode.**  
The [ Rec. Mode] menu appears.
- 2 Use the four-way controller (▲▼) to select [Green Button].**
- 3 Press the four-way controller (▶).**  
A pull-down menu appears.

- 4** Use the four-way controller (▲▼) to select a function and press the OK button.

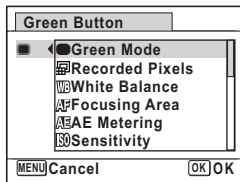

- 5** Press the MENU button.

The selected function is assigned to the Green button.

### To Use the Green Button

- 1** Press the Green button in mode.

The function assigned to the Green button is called up.

- 2** Use the four-way controller (◀▶) to change the setting and press the OK button.

The camera returns to capture status.



Taking Pictures in the Basic Mode (Green Mode) p.72

Recording Sound (Voice Recording) p.158



When the function other than the (Green) mode and Voice Recording is assigned to the Green button, the camera returns to the original screen if no operation is performed for 1 minute after the Green button is pressed.

# Recording Movies

## Recording a Movie

This mode enables you to record movies. Sound is recorded at the same time.

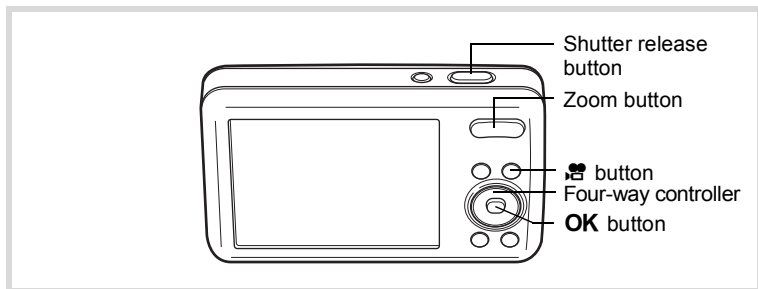

### 1 Point the camera at your subject in mode.

When the camera detects a person's face, the Face Detection function is activated and the face detection frame appears (p.69). (The frame disappears when recording starts.)

### 2 Press the button.

The camera automatically focuses on the subject and compensates the exposure. Recording starts.

You can continue recording until the built-in memory or the SD Memory Card is full, or the size of the recorded movie reaches 2 GB.

The following information appears on the display.

- 1 Movie mode
- 2 Recording (blinks)
- 3 Remaining recordable time
- 4 Recorded time
- 5 Movie SR setting

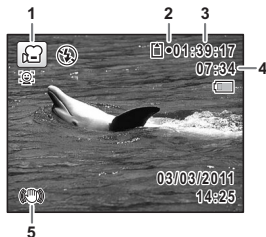

You can change the captured area by pressing the zoom button.

- Right ( ) Enlarges the subject.  
Left ( ) Widens the area that is captured by the camera.

## Press the button.



Recording stops.

Playing Back a Movie  p.117



- The flash does not discharge while recording a movie.
- The autofocus system does not operate while recording a movie.
- You can use the optical zoom only before recording, while the Digital Zoom is available both before and during recording.
- Recording does not start while a menu screen is being displayed or in the playback mode even if the  button is pressed.
- You can use the optional remote control (p.86) to record movies while you are away from the camera.

### Keeping the Button Pressed







If you keep the  button pressed for more than one second, recording will continue as long as you keep the button pressed. Shooting stops when you take your finger off the  button.











## Selecting the Recorded Pixels and Frame Rate for Movies

You can choose from the following recorded pixels and frame rate settings for movies.

The more pixels there are, the clearer the details and the bigger the file size. The more frames per second, the better the quality of the movie, but the file size becomes larger.

Setting	Recorded Pixels	Frame Rate	Use
	1280×720	30 fps	Records images in HDTV format (16:9). Movement is recorded smoothly. (default setting)
	1280×720	15 fps	Records images in HDTV format (16:9). Increases the total recording time by making the file size smaller.
	640×480	30 fps	Suitable for viewing on a TV or computer screen. Movement is recorded smoothly.
	640×480	15 fps	Suitable for viewing on a TV or computer screen. Increases the total recording time by making the file size smaller.
	320×240	30 fps	Suitable for posting on a website or attaching to an e-mail. Movement is recorded smoothly.
	320×240	15 fps	Suitable for posting on a website or attaching to an e-mail. Increases the total recording time by making the file size smaller.

\* The frame rate (fps) indicates the number of frames per second.

- 1 Press the MENU button in  mode.**  
The [ Rec. Mode] menu appears.
- 2 Press the four-way controller () or zoom button towards the right (.**  
The [ Movie] menu appears.
- 3 Use the four-way controller ( ) to select [Recorded Pixels].**
- 4 Press the four-way controller (.**  
A pull-down menu appears.

- 5** Use the four-way controller (▲▼) to select the number of recorded pixels and frame rate.

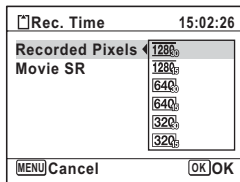

- 6** Press the OK button.

The setting is saved.

- 7** Press the MENU button.

The camera returns to capture status.

## Setting the Movie SR (Movie Shake Reduction) Function

You can correct camera shake while you are recording a movie with the Movie SR (Movie Shake Reduction) function.

- 1** Press the MENU button in mode.

The [ Rec. Mode] menu appears.

- 2** Press the four-way controller (▶) or zoom button towards the right (Q).

The [ Movie] menu appears.

- 3** Use the four-way controller (▲▼) to select [Movie SR].

- 4** Use the four-way controller (◀▶) to select  or .

- Corrects camera shake.
- Does not correct camera shake.

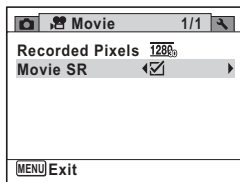

- 5** Press the MENU button.

The camera returns to capture status.

# Saving the Settings (Memory)

The Memory function is for saving the current camera settings when the camera is turned off.

For some camera settings, the Memory function is always set to  (On) (the settings are saved when the camera is turned off), while for others you can choose  or  (Off) (to choose whether the settings are saved or not when the camera is turned off). The items which can be set to  or  in the Memory function are shown in the table below. (For items which are not listed here, the selected settings are always saved when the camera is turned off.)

If you select , the settings will be saved in the status they are in immediately before the camera is turned off. If you select , the settings will be reset to the defaults when the camera is turned off. The table below also shows whether the Memory default setting for each item is  or .

Item	Description	Default Setting	Page
Flash Mode	The flash mode set with the four-way controller (◀)	<input checked="" type="checkbox"/>	p.88
Drive Mode	The drive mode set with the four-way controller (▲)	<input type="checkbox"/>	p.84 p.85
Focus Mode	The focus mode set with the four-way controller (▶)	<input type="checkbox"/>	p.89
Zoom Position	The zoom position set with the zoom button	<input type="checkbox"/>	p.73
MF Position	The manual focus position set with the four-way controller (▲▼)	<input type="checkbox"/>	p.90
White Balance	The [White Balance] setting on the [📷 Rec. Mode] menu	<input type="checkbox"/>	p.96
Sensitivity	The [Sensitivity] setting on the [📷 Rec. Mode] menu	<input type="checkbox"/>	p.99
EV Compensation	The [EV Compensation] setting on the [📷 Rec. Mode] menu	<input type="checkbox"/>	p.94
AE Metering	The [AE Metering] setting on the [📷 Rec. Mode] menu	<input type="checkbox"/>	p.98
Digital Zoom	The [Digital Zoom] setting on the [📷 Rec. Mode] menu	<input checked="" type="checkbox"/>	p.74
Face Detection	The [Face Detection] setting on the [📷 Rec. Mode] menu	<input type="checkbox"/>	p.69
DISPLAY	The information display mode set with the <b>OK/DISPLAY</b> button	<input type="checkbox"/>	p.20
File No.	If a new SD Memory Card is inserted when set to <input checked="" type="checkbox"/> (On), file numbers are assigned sequentially	<input checked="" type="checkbox"/>	—

---

**1** Press the **MENU** button in  mode.

The [ Rec. Mode] menu appears.

---

**2** Use the four-way controller ( ) to select [Memory].

---

**3** Press the four-way controller () .

The [Memory] screen appears.

---

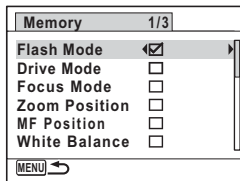
**4** Use the four-way controller ( ) to choose an item.

---

**5** Use the four-way controller ( ) to select  or .

---

**6** Press the **MENU** button twice.

The camera returns to capture status.

# **4** **Playing Back and Deleting Images**

---

<b>Playing Back Images .....</b>	<b>116</b>
<b>Deleting Images and Sound Files .....</b>	<b>126</b>
<b>Connecting the Camera to AV Equipment .....</b>	<b>132</b>

# Playing Back Images

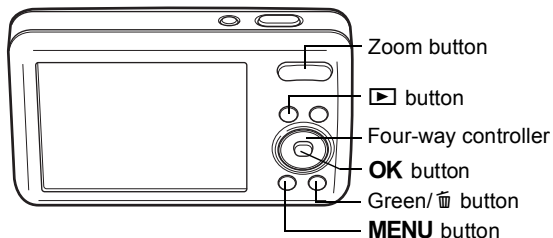

4

Playing Back and Deleting Images

## Playing Back Still Pictures

- 1 Press the ▶ button after taking a picture.

The camera enters the ▶ mode and the captured image appears on the display (single-image display).

File number



- 2 Press the four-way controller (◀▶).

The previous or next image appears.

### To Delete the Displayed Image

Press the 🗑 button while the image is displayed to display the Delete screen. Press the four-way controller (▲) to select [Delete] and press the OK button.



For information on other deletion procedures see p.126

## Playing Back a Movie

You can play back the movies you have taken. Recorded sound is played back at the same time.

**1** In  mode, use the four-way controller (◀▶) to choose the movie you want to play back.

**2** Press the four-way controller (▲).

Playback starts.



### Available operations during playback

Zoom button towards the right (Q)	Increases the volume.
Zoom button towards the left (K)	Reduces the volume.
Four-way controller (▲)	Pauses playback.
Four-way controller (▶)	Fast-forwards playback while the button is held down.
Four-way controller (◀)	Plays back in reverse. Fast-reverses playback while the button is held down.

### Available operations while playback is paused

Four-way controller (▲)	Resumes playback.
Four-way controller (▶)	Forwards the frame.
Four-way controller (◀)	Reverses the frame.

**3** Press the four-way controller (▼).

Playback stops.

# Multi-Image Display





## Four-Image Display/Nine-Image Display

You can display four or nine thumbnails of captured images at a time.

**1** In  mode, press the zoom button towards the left ().

The four-image display appears showing a page consisting of four thumbnail images. Press the zoom button towards the left () again to switch to nine-image display.

A page consisting of four or nine thumbnail images appears. The displayed images change four or nine images at a time page by page.

Use the four-way controller () to move the frame. If there are too many images to display on one page, pressing the four-way controller () while the image  is selected will display the previous page. Similarly, if you choose the image  and press the four-way controller (), the next page appears.

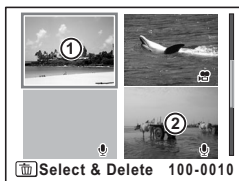

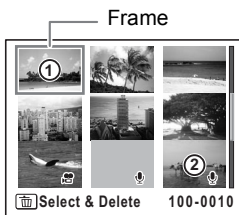

Four-Image Display



Nine-Image Display

The icons that appear on the images indicate the following:

(No icon)	Still picture without sound
	Movie (the first frame appears)
 (With image)	Still picture with sound
 (Without image)	Sound file only

Press the **OK** button to switch to single-image display of the selected image.

Press the  button to switch to  mode.



## Folder Display/Calendar Display

In nine-image display, press the zoom button towards the left (⏪) to switch to folder display or calendar display. Press the Green button to switch between folder display and calendar display.

### 1 In mode, press the zoom button towards the left (⏪) three times.

The screen changes to folder display or calendar display.

#### Folder display

The folder list with recorded images and sound files appears on the screen display.

Four-way controller (▲▼◀▶)	Moves the frame.
Zoom button towards the right (Q)/OK button	Displays the images in the selected folder in nine-image display.
<b>MENU</b> button	Returns to nine-image display.

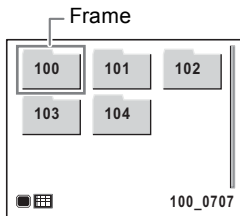

#### Calendar display

Images and sound files are displayed by date in calendar format.

A thumbnail of the first image recorded on each date is displayed on the calendar.

 appears for the dates on which a sound file was the first recorded file.

Four-way controller (▲▼◀▶)	Moves the frame.
Zoom button towards the right (Q)	Displays the images recorded on the selected date in nine-image display.
<b>OK</b> button	Displays the first image recorded on the selected date in single-image display.
<b>MENU</b> button	Returns to nine-image display.

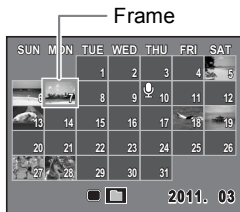

## Using the Playback Functions

### 1 Press the four-way controller (▼) in mode.

The Playback Mode Palette appears.

### 2 Use the four-way controller (▲▼◀▶) to choose a playback mode.



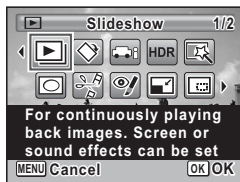





The guide for the selected function appears below.









### 3 Press the OK button.

The selected playback function is called up.

## Playback Mode Palette

Playback Mode	Description	Page
 Slideshow	For continuously playing back images. Screen or sound effects can be set.	p.121
 Image Rotation	Rotates captured images. Useful when viewing vertical images on a TV.	p.124
 Miniature Filter	Processes the subjects in the images to look like miniature objects.	p.138
<b>HDR</b> HDR Filter	Processes image into HDR-like image.	p.138
 Digital Filter	For modifying images with a Color filter or Soft filter.	p.140
 Frame Composite	For composing an image with a frame. Select Overwrite or Save as to save.	p.145
 Movie Editing	Save as Still Image	p.148
	Divide Movies	
 Red-eye Compensation	For compensating red-eye. May not work due to the condition of the image.	p.144
 Resize	Changes Recorded Pixels to make the file size smaller.	p.136

	Cropping	For cropping images to the size you like. Saved as a new image.	p.137
	Image/Sound Copy	For copying images and sounds between the built-in memory and SD Memory Card.	p.150
	Voice Memo	Attaches sound to images. Recording is possible till the memory card is full.	p.161
	Protect	Protects images and sounds from accidental deletion. Formatting will delete protected data.	p.129
	DPOF	For the print settings. Useful when printing at a printing service.	p.153
	Start-up Screen	For setting a captured image as the Start-up Screen.	p.177

## Slideshow

You can play back recorded images one after another.

**1** In  mode, use the four-way controller (◀▶) to choose the image to start the slideshow with.

**2** Press the four-way controller (▼).  
The Playback Mode Palette appears.

**3** Use the four-way controller (▲▼◀▶) to select  (Slideshow).



**4** Press the OK button.  
The slideshow setting screen appears.

**5** Use the four-way controller (▲▼) to select [Start].

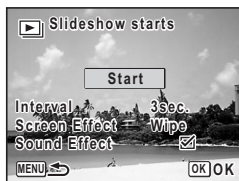

**6 Press the OK button.**

The slideshow starts.

Pressing the **OK** button during the slideshow pauses the slideshow. To resume the slideshow, press the **OK** button again.

**7 Press any button other than the OK button.**

The slideshow stops.

**To Set the Slideshow Conditions**

You can set the playback interval and also a screen effect and sound effect for when one image changes to the next.

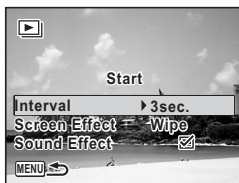
**1 Use the four-way controller (▲▼) to select [Interval] in Step 5 on p.121.****2 Press the four-way controller (▶).**

A pull-down menu appears.

**3 Use the four-way controller (▲▼) to select the interval and press the OK button.**

Choose from [3sec.], [5sec.], [10sec.], [20sec.] or [30sec.].

**4 Use the four-way controller (▲▼) to select [Screen Effect].****5 Press the four-way controller (▶).**

A pull-down menu appears.

- 6** Use the four-way controller (▲ ▼) to choose the screen effect and press the **OK** button.

Wipe	The next image slides over the previous one from left to right
Checker	The next image appears in small square mosaic blocks
Fade	The current image gradually fades out and the next image fades in
Random	Various effects are used randomly
Off	No effect

- 7** Use the four-way controller (▲ ▼) to select [Sound Effect].

- 8** Use the four-way controller (◀ ▶) to select  or .

Except when the [Screen Effect] is set to [Off], you can choose  (On) or  (Off) for the sound that is played when one image changes to the next.

- 9** Use the four-way controller (▲ ▼) to select [Start] and press the **OK** button.

The slideshow starts using the selected interval and effect.



- The slideshow will continue until you press any button other than the **OK** button.
- Movies and pictures with sound will be played through to the end before the next picture is played back, regardless of the interval setting. However, pressing the four-way controller (▶) while playing back a movie or a picture with sound skips to the next image.
- Sound files made in Voice Recording are not played back in the slideshow.
- When [Random] is selected for the screen effect, the interval is fixed and the sound effect is set to off. Also the sound of pictures with sound will not be played back.

Connecting the Camera to AV Equipment p.132

## Rotating an Image

### 1 Press the button after taking a picture.

The image appears on the display.

### 2 Press the four-way controller ( $\blacktriangledown$ ).

The Playback Mode Palette appears.

### 3 Use the four-way controller ( $\blacktriangle\blacktriangledown\blacktriangleleft\blacktriangleright$ ) to select (Image Rotation).

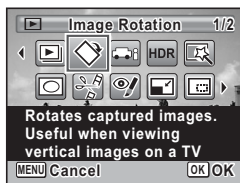

### 4 Press the OK button.

The rotation selection screen (0°, Right 90°, Left 90°, or 180°) appears.

### 5 Use the four-way controller ( $\blacktriangle\blacktriangledown\blacktriangleleft\blacktriangleright$ ) to choose the rotation direction and press the OK button.

The rotated image is saved.

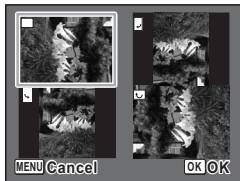

- Movies cannot be rotated.
- Protected images can be rotated, but they cannot be saved in a rotated state.

## Zoom Playback

You can magnify an image up to ten times.

**1** In  mode, use the four-way controller (◀▶) to choose the image you want to magnify.

**2** Press the zoom button towards the right (Q).

The image is magnified (×1.1 to ×10). Continuing to press the zoom button towards the right (Q) changes the magnification continuously.

You can use the guide mark “+” that appears at the bottom left of the screen to check which portion of the image is magnified.

**Available operations while an image is magnified**

Four-way controller (▲▼◀▶)	Moves the position to be magnified.
Zoom button towards the right (Q)	Makes the image bigger (max. ×10).
Zoom button towards the left (Q)	Makes the image smaller (min. ×1.1).



Guide

**3** Press the OK button.

The image returns to single-image display.



Movies cannot be magnified.

# Deleting Images and Sound Files

You can delete images and sound files that you do not want to keep.

## Deleting a Single Image

You can delete a single image or sound file.



Protected images and sound files cannot be deleted (p.129).

**1** In  mode, use the four-way controller (◀▶) to choose the image/sound file you want to delete.

**2** Press the  button.  
A confirmation dialog appears.

**3** Use the four-way controller (▲▼) to select [Delete].





**4** Press the **OK** button.  
The image or sound file is deleted.

## To Delete the Sound from an Image

If sound (voice memo) has been added to an image (p.161), you can delete the sound without deleting the image.

**1** In  mode, use the four-way controller (◀▶) to choose the image with sound.

 appears on the images with sound.

**2** Press the  button.  
A confirmation dialog appears.



- 3** Use the four-way controller (▲▼) to select [Delete Sound].



- 4** Press the **OK** button.

The sound data is deleted.



- Select [Delete] in Step 3 to delete both the image and sound data.
- You cannot delete only the sound from a movie.

## Deleting Selected Images and Sound Files

You can delete several images/sound files selected from the four-/nine-image display at once.



Protected images and sound files cannot be deleted (p.129).

- 1** In  mode, press the zoom button towards the left () **once or twice.**

Four-image display or nine-image display appears.

- 2** Press the  button.

 appears on the images and sound files.



- 3 Use the four-way controller (▲▼◀▶) to choose the images and sound files that you want to delete and press the OK button.**

☑ appears on the selected images and sound files.

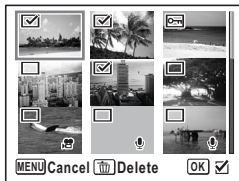

If you select an image and press the zoom button towards the right (Q), the selected image appears in single-image display as long as the button is pressed, enabling you to check whether you really want to delete it or not. (The display returns to four/nine-image display when you release the button.) However, protected images cannot be displayed in single-image display.

- 4 Press the  button.**

A confirmation dialog appears.

- 5 Use the four-way controller (▲▼) to select [Select & Delete].**



- 6 Press the OK button.**

The selected images and sound files are deleted.

## Deleting All Images and Sound Files

You can delete all the images and sound files at once.



Protected images and sound files cannot be deleted (p.129).

- 1 Press the MENU button in  mode.**

The [ Setting] menu appears.

- 2** Use the four-way controller (▲▼) to select [Delete All].

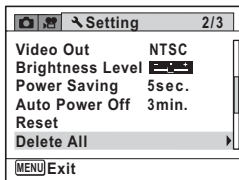

- 3** Press the four-way controller (▶).  
The [Delete All] screen appears.

- 4** Use the four-way controller (▲▼) to select [Delete All].

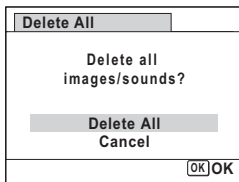

- 5** Press the OK button.  
All the images and sound files are deleted.

## Protecting Images and Sound Files from Deletion (Protect)

You can protect stored images and sound files from being accidentally deleted.

- 1** In [ ] mode, use the four-way controller (◀▶) to choose the image you want to protect.
- 2** Press the four-way controller (▼).  
The Playback Mode Palette appears.
- 3** Use the four-way controller (▲▼◀▶) to select  (Protect).



**4 Press the OK button.**

The screen for selecting [Single Image/Sound] or [All Images/Sounds] appears.

**5 Use the four-way controller (▲▼) to select [Single Image/Sound].****6 Press the OK button.**

The message [Protects this image/sound] appears.

To protect another image or sound file, use the four-way controller (◀▶) to select another image or sound file.

**7 Use the four-way controller (▲▼) to select [Protect].****8 Press the OK button.**

The selected image or sound file is protected and the screen shown in Step 5 reappears.

To protect other images or sound files, repeat Steps 5 to 8.

Select [Cancel] to exit the Protect setting.



- To cancel the protection of the data, select [Unprotect] in Step 7.
-  appears on the protected images and sound files during playback.

## To Protect All Images and Sound Files

- 1** Select [All Images/Sounds] in Step 5 on p.130.

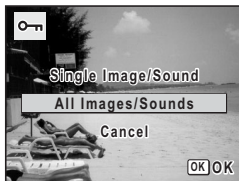

- 2** Press the OK button.

- 3** Use the four-way controller (▲▼) to select [Protect].

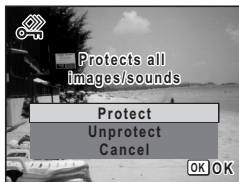

- 4** Press the OK button.

All the images and sound files are protected and the screen shown in Step 1 reappears.

- 5** Use the four-way controller (▲▼) to select [Cancel] and press the OK button.

The Playback Mode Palette reappears.



Protected images and sound files will be deleted if the SD Memory Card is formatted (p.164).



To cancel the protection of all your images and sound files, select [Unprotect] in Step 3.

# Connecting the Camera to AV Equipment

By using the supplied AV cable (I-AVC116), you can capture and play back images on equipment with a video input terminal, such as a TV.

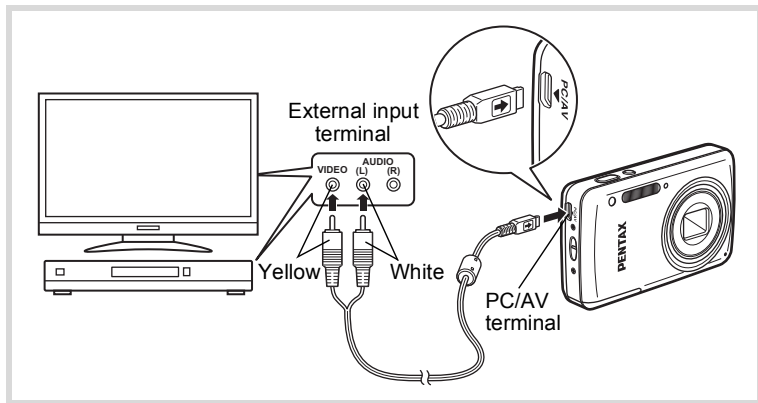

4

Playing Back and Deleting Images

- 1 Turn the AV equipment and camera off.**
- 2 Face the ▶ mark on the AV cable towards the ◀ mark on the camera, and connect the cable to the PC/AV terminal.**
- 3 Connect the other ends of the AV cable to the video input terminal and audio input terminal of the AV equipment.**

When using stereo sound equipment, insert the sound terminal into the L (white) terminal.

- 4 Turn the AV equipment on.**

When the equipment that the camera is connected to and the equipment that plays back images are different, turn both on.

When viewing images on AV equipment with multiple video input terminals (such as a TV), refer to the operation manual of the equipment and select the video input terminal to which the camera is connected.

## 5 Turn the camera on.



- Depending on the country or region, images and sound files may fail to be played back if the video output format is set differently from the one in use there. If this happens, change the video output format setting (p.173).
- The camera display turns off and the volume cannot be adjusted by pressing the zoom button while the camera is connected to AV equipment.



When connecting to and playing back images on AV equipment, image data is output at normal screen resolution. To view movies recorded at  $\overline{1280}$  (1280×720, 30 fps) and  $\overline{1280}$  (1280×720, 15 fps) in HDTV, transfer the data to a computer and play it back on the computer (p.181).

## Memo



# 5 Editing and Printing Images

---

<b>Editing Images .....</b>	<b>136</b>
<b>Setting the Printing Service (DPOF) .....</b>	<b>153</b>

## **About printing**

The following options are available for printing images taken with this camera.

- 1 Use a printing service.**
- 2 Use your printer with an SD Memory Card slot to print directly from the SD Memory Card.**
- 3 Use your computer's software to print images.**

## Changing the Image Size (Resize)

By changing the recorded pixels of a selected image, you can make the file size smaller than the original. You can use this function to continue taking pictures when the SD Memory Card or the built-in memory is full, by making the images smaller and overwriting the original images to make more space available.



- Images taken with the recorded pixels of **10M151** (3216×3216)/**2M169** (1920×1080) and movies cannot be resized.
- You cannot select a larger resolution than that of the original image.

**1** In mode, use the four-way controller (◀▶) to choose the image you want to resize.

**2** Press the four-way controller (▼).  
The Playback Mode Palette appears.

**3** Use the four-way controller (▲▼◀▶) to select (Resize).



**4** Press the OK button.

The screen for choosing the number of recorded pixels appears.

**5** Use the four-way controller (◀▶) to select the number of recorded pixels.



## 6 Press the OK button.

A confirmation dialog for overwriting the image appears. If the selected image is protected, the processed image is saved as a new image and the following confirmation dialog does not appear.

## 7 Use the four-way controller (▲▼) to select [Overwrite] or [Save as].

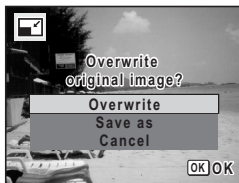

## 8 Press the OK button.

The resized image is saved.

## Cropping Images

You can delete the unwanted part of a picture and save the cropped image as a new image.



Images taken with the recorded pixels of **10M 16:9** (3216×3216)/**2M 16:9** (1920×1080) and movies cannot be cropped.

## 1 In mode, use the four-way controller (◀▶) to choose the image you want to crop.

## 2 Press the four-way controller (▼).

The Playback Mode Palette appears.

## 3 Use the four-way controller (▲▼◀▶) to select (Cropping).



**4 Press the OK button.**

The cropping screen appears.

The largest size of cropped image is shown with a green frame on the screen. The cropped image cannot be larger than this cropping frame size.

**5 Choose the cropping area.**

Change the size and/or position of the cropping frame by the following operations.

Zoom button	Changes the size of the cropping frame.
Four-way controller (▲▼◀▶)	Moves the cropping frame up, down, left and right.
Green button	Rotates the cropping frame. <ul style="list-style-type: none"> <li>The button is displayed only when the cropping frame can be rotated.</li> </ul>

**5 6 Press the OK button.**

The cropped image is saved with a new file name.

The number of recorded pixels is selected automatically according to the size of the cropped image.

**Processing Images with the Miniature/HDR Filter**

This function lets you perform special processing on the selected image.

 Miniature Filter	Processes the subjects in the images to look like miniature objects. The processed image is saved with the recorded pixels of <b>5M</b> (2592×1944). Images of size <b>5M</b> or smaller cannot be processed.
<b>HDR</b> HDR Filter	Processes image into HDR-like image.



Movies and images taken with another camera cannot be processed using the Miniature/HDR Filter function.

**1 In  mode, use the four-way controller (◀▶) to choose the image you want to edit.**

## 2 Press the four-way controller (▼).

The Playback Mode Palette appears.

## 3 Use the four-way controller (▲▼◀▶) to select or HDR.

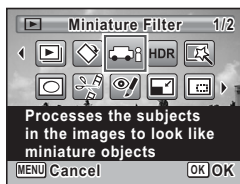



## 4 Press the OK button.

When the  mode is selected, the screen for selecting the area to be blurred is displayed.

When the **HDR** mode is selected, proceed to Step 7.

## 5 Use the four-way controller (◀▶) to select an option.

	Processes the image so that the top of the image is blurred as if only the bottom of the image is in focus.
	Processes the image so that the top and bottom of the image is blurred as if only the center of the image is in focus.
	Processes the image so that the bottom of the image is blurred as if only the top of the image is in focus.



## 6 Press the OK button.

A confirmation dialog for overwriting the image appears.

If the selected image is protected, the processed image is saved as a new image and the following confirmation dialog does not appear.

## 7 Use the four-way controller (▲▼) to select [Overwrite] or [Save as].

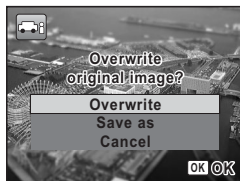

## 8 Press the OK button.

The camera returns to  mode and the processed image is displayed.



## Processing Images with the Digital Filters

This function lets you change the color tones and perform special processing on the selected image.





B&W	Processes the image into one that has the look of a black and white photograph.
Sepia	Processes the image into one that has the look of a sepia photograph.
Toy Camera	Processes the image that looks as though it was shot with a toy camera.
Retro	Processes the image into one that has the look of an old photo.
Color	Processes the image using the selected color filter. You can choose from six filters: red, pink, purple, blue, green, and yellow.
Extract Color	Extracts only a specific color and processes the rest of the image into black and white. You can choose from three filters: red, green, and blue.
Color Emphasis	There are four filters: Sky Blue/Fresh Green/Delicate Pink/Autumn Leaves.
Soft	Processes the image into one that appears soft overall.
Brightness	Adjusts the brightness of the image.



Movies and images taken with another camera cannot be processed using the Digital Filter function.

**1** In  mode, use the four-way controller ( ) to choose the image you want to edit.

**2** Press the four-way controller ().  
The Playback Mode Palette appears.

**3** Use the four-way controller (   ) to select  (Digital Filter).

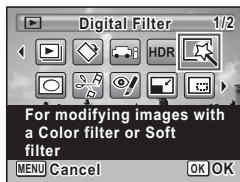

## 4 Press the OK button.

The filter selection screen appears.

- 1 B&W
- 2 Sepia
- 3 Toy Camera
- 4 Retro
- 5 Color
- 6 Extract Color
- 7 Color Emphasis
- 8 Soft
- 9 Brightness

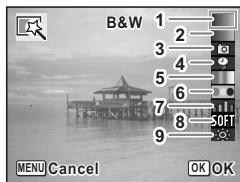

Subsequent steps vary depending on your selection.

### To Select a B&W, Sepia or Soft Filter

## 5 Use the four-way controller (▲▼) to choose a filter.

The preview image of the result of the filter effect appears.

## 6 Press the OK button.

A confirmation dialog for overwriting the image appears.

If the selected image is protected, the processed image is saved as a new image and the following confirmation dialog does not appear.

## 7 Use the four-way controller (▲▼) to select [Overwrite] or [Save as].

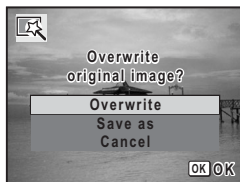

## 8 Press the OK button.

The image processed with the filter is saved.

## To Select a Retro, Color, Extract Color or Color Emphasis Filter

### 5 Use the four-way controller (▲▼) to choose a filter.

The preview image of the result of the filter effect appears.

### 6 Use the four-way controller (◀▶) to choose the color.

The color filter changes in the following sequence each time the four-way controller (▶) is pressed.



Retro	Original image → Amber → Blue
Color	Red → Pink → Purple → Blue → Green → Yellow
Extract Color	Red → Green → Blue
Color Emphasis	Sky Blue → Fresh Green → Delicate Pink → Autumn Leaves

### 7 Press the OK button.

A confirmation dialog for overwriting the image appears. If the selected image is protected, the processed image is saved as a new image and the following confirmation dialog does not appear.

### 8 Use the four-way controller (▲▼) to select [Overwrite] or [Save as].

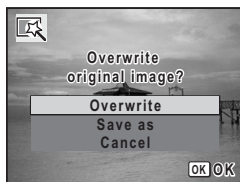

### 9 Press the OK button.

The image processed with the filter is saved.



## To Select a Toy Camera or Brightness Filter

### 5 Use the four-way controller (▲▼) to choose a filter.

The preview image of the result of the filter effect appears.

### 6 Use the four-way controller (◀▶) to adjust the effect.



	Four-way controller (◀)	Default Setting	Four-way controller (▶)
Toy Camera	Weak	Standard	Strong
Brightness	Dark	Standard	Bright

### 7 Press the OK button.

A confirmation dialog for overwriting the image appears.

If the selected image is protected, the processed image is saved as a new image and the following confirmation dialog does not appear.

### 8 Use the four-way controller (▲▼) to select [Overwrite] or [Save as].

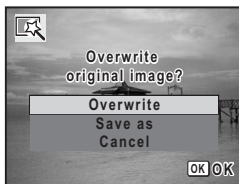

### 9 Press the OK button.

The image processed with the filter is saved.

## Compensating for an Unwanted Red-eye Effect

You can correct images where the flash has caused the subject to appear with red eyes.



The red-eye compensation function can only be used with still pictures taken with this camera. The red-eye compensation function cannot be used on movies and on images where red eyes cannot be detected on the camera. An error message appears in Step 4.

**1** In mode, use the four-way controller (◀▶) to choose the image you want to correct.

**2** Press the four-way controller (▼).

The Playback Mode Palette appears.

**3** Use the four-way controller (▲▼◀▶) to select (Red-eye Compensation).



**4** Press the OK button.

A confirmation dialog for overwriting the image appears.

If the selected image is protected, the processed image is saved as a new image and the following confirmation dialog does not appear.

**5** Use the four-way controller (▲▼) to select [Overwrite] or [Save as].

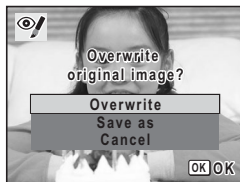

**6** Press the OK button.

The processed image is saved.

## Adding a Frame (Frame Composite)

This function lets you add a decorative frame to still pictures. There are three frames already stored in the camera.



The Frame Composite function cannot be used on images taken with the recorded pixels of **10M 1080i** (3216×3216)/**10M 1080** (4224×2376)/**2M 1080** (1920×1080), movies, and images of size **3M** (2048×1536) or smaller. An error message appears in Step 4.

**1** In mode, use the four-way controller (◀▶) to choose the image to which you want to add a frame.

**2** Press the four-way controller (▼).

The Playback Mode Palette appears.

**3** Use the four-way controller (▲▼◀▶) to select (Frame Composite).

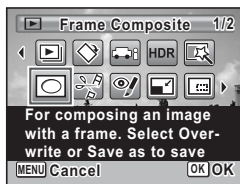

**4** Press the OK button.

The 9-frame display of the frame selection screen appears.

**5** Use the four-way controller (▲▼◀▶) to choose a frame.

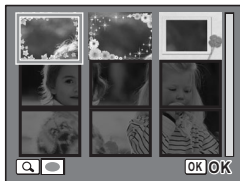

## 6 Press the zoom button towards the right (Q).

The selected frame appears in single-image display.

You can choose another frame using either of the following operations.

Four-way controller (◀▶)	Press to choose a different frame.
Zoom button towards the left (Q)	Returns to the 9-frame display of the frame selection screen, and then lets you choose a different frame in the same way as Step 5.



## 7 Press the OK button.

The frame position and size adjustment screen appears.

You can adjust the image using the following operations.

Four-way controller (▲▼◀▶)	Press to adjust the position of the image
Zoom button	Makes the image larger or smaller.



## 8 Press the OK button.

A confirmation dialog for overwriting the image appears.

If the selected image is protected, the processed image is saved as a new image and the following confirmation dialog does not appear.

## 9 Use the four-way controller (▲▼) to select [Overwrite] or [Save as].



## 10 Press the OK button.

The processed image is saved with the recorded pixels of **3M** (2048×1536).

## Optional Frames

In addition to the built-in frames that come with the Optio S1, there are 90 different optional frames included on the provided CD-ROM (S-SW116). You can save the optional frames to the camera's built-in memory or an SD Memory Card. To save them to the built-in memory, first remove the SD Memory Card before proceeding.

### To Copy Frames

- 1 Connect the camera to a computer using the provided USB cable (I-USB116).**

Refer to "Connecting to a Computer" (p.181) for instructions on connecting the camera to a computer.

- 2 When the device detection window opens, click [Cancel].**

- 3 Insert the CD-ROM (S-SW116) into the CD-ROM drive.**

- 4 When the installer window opens, click [EXIT].**

- 5 Copy the desired files from the FRAME folder in the root directory of the CD-ROM to the FRAME folder on the camera (removable disk).**

For information on working with files on a computer, refer to the instruction manual supplied with the computer.

- 6 Disconnect the USB cable from the computer and camera.**

Refer to "Connecting to a Computer" (p.181) for instructions on disconnecting the cable.

## To Use a New Frame

Frames downloaded from the PENTAX website or other source can be used for adding a frame to pictures.



- Extract the downloaded frame and copy it to the FRAME folder in the built-in memory or on the SD Memory Card.
- The FRAME folder is created when the SD Memory Card is formatted with this camera.
- For more information on downloading, refer to the PENTAX website.
- Up to a total of 99 frames including the three default frames can be stored, but using large numbers of frames may slow down processing speed.

## Editing Movies

You can extract a frame from the recorded movie to save as a still picture or divide a movie into two or more segments.

5

**1** In mode, use the four-way controller (◀▶) to choose the movie you want to edit.

**2** Press the four-way controller (▼).  
The Playback Mode Palette appears.

**3** Use the four-way controller (▲▼◀▶) to select (Movie Editing).



**4** Press the OK button.  
The movie editing selection screen appears.  
Subsequent steps vary depending on your selection.



## To Save a Frame from a Movie as a Still Picture

**5** Select **[Save as Still Image]** on the movie editing selection screen.

**6** Press the **OK** button.

The screen appears for selecting a frame to be saved as a still picture.

**7** Use the four-way controller (**▲▼◀▶**) to choose the frame you want to save.

- ▲ Plays or pauses the movie
- ▼ Stops the movie and returns to the first frame
- ◀ Reverses the movie frame by frame
- ▶ Advances the movie frame by frame

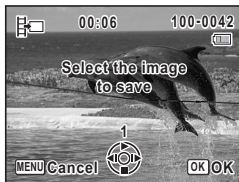

**8** Press the **OK** button.

The selected frame is saved as a still picture.

## To Divide a Movie

**5** Select **[Divide Movies]** on the movie editing selection screen.

**6** Press the **OK** button.

The screen for choosing the dividing position appears.

**7** Use the four-way controller (**▲▼◀▶**) to determine the dividing position.

- ▲ Plays or pauses the movie
- ▼ Stops the movie and returns to the first frame
- ◀ Reverses the movie frame by frame
- ▶ Advances the movie frame by frame



**8** Press the **OK** button.

A confirmation dialog appears.

- 9** Use the four-way controller (▲▼) to select [Divide].

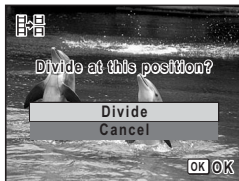

- 10** Press the OK button.

The movie is divided at the specified position, each segment is saved as a new file, and the original movie is deleted.



Protected movies cannot be divided.

## 5 Copying Images and Sound Files

You can copy images and sound files from the built-in memory to the SD Memory Card and vice versa. This function can be selected only when an SD Memory Card has been inserted in the camera.



Make sure that the camera is turned off before inserting or removing the SD Memory Card.

- 1** Press the four-way controller (▼) in  mode.

The Playback Mode Palette appears.

- 2** Use the four-way controller (▲▼◀▶) to select  (Image/Sound Copy).





### 3 Press the OK button.

The copying method selection screen appears.  
Subsequent steps vary depending on your selection.

#### To Copy Files from the Built-in Memory to the SD Memory Card

All the images and sound files in the built-in memory are copied to the SD Memory Card at once. Before copying the images, make sure that there is enough space on the SD Memory Card.

### 4 Use the four-way controller (▲▼) to select [●→SD].



### 5 Press the OK button.

All the images and sound files are copied to the SD Memory Card.

#### To Copy Files from the SD Memory Card to the Built-in Memory

Selected images and sound files from the SD Memory Card are copied to the built-in memory one by one.

### 4 Use the four-way controller (▲▼) to select [SD→●].

### 5 Press the OK button.

### 6 Use the four-way controller (◀▶) to select the image/sound file you want to copy.



# 7

## Press the OK button.

The selected image/sound file is copied to the built-in memory. To copy other images or sound files, repeat Steps 4 to 7. Select [Cancel] to exit the copy operation.



- Images with sounds are copied with the sound.
- When a file is copied from the SD Memory Card to the built-in memory, it is assigned a new file name.

# Setting the Printing Service (DPOF)

DPOF (Digital Print Order Format) is the format for storing print order data on still pictures captured with a digital camera. Once the print order data has been stored, the pictures can be printed according to the DPOF settings by using a DPOF-compatible printer or at a photo processing lab.

**Caution**

- The DPOF settings can be applied only to still pictures. Movies and sound files cannot be processed with the DPOF settings.
- If the picture already has the date and/or time imprinted on it (p.106), do not set [Date] to  (On) in DPOF setting. If you select , the imprinted date and/or time may overlap.

## Printing a Single Image

Set the following items for each image.

Copies	Choose the number of copies up to 99.
Date	Specify whether to imprint the date on the pictures.

**1** In  mode, press the four-way controller (▼).  
The Playback Mode Palette appears.

**2** Use the four-way controller (▲▼◀▶) to select  (DPOF).



**3** Press the OK button.

The DPOF setting method selection screen appears.

- 4** Use the four-way controller (▲▼) to select [Single Image].



- 5** Press the **OK** button.

The message [Applies DPOF settings to this image] appears.

- 6** Use the four-way controller (◀▶) to select an image.

If DPOF settings have already been made for the selected image, the previous number of copies and date setting (☑ or ☐) will be displayed.

- 7** Use the four-way controller (▲▼) to choose the number of copies.

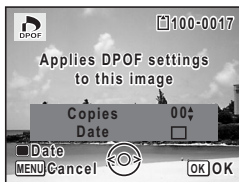

- 8** Press the **Green** button to switch  or  for [Date] setting.

- The date will be imprinted.
- The date will not be imprinted.

To continue setting the DPOF print order data, repeat Steps 6 to 8.



- 9** Press the **OK** button.

The settings are saved and the screen shown in Step 4 reappears.



Depending on the printer or printing equipment at the photo processing lab, the date may not be imprinted on the pictures even if ☑ (On) is selected for [Date] in DPOF setting.



To cancel DPOF settings, set the number of copies to [00] in Step 7 and press the **OK** button.

## Printing All Images

DPOF settings are applied to all the images stored in the camera.

**1** Select **[All Images]** in Step 4 on p.154.

**2** Press the **OK** button.

The message [Applies DPOF settings to all images] appears.

**3** Choose the number of copies and switch  or  for **[Date]** setting.

Refer to Steps 7 and 8 in “Printing a Single Image” (p.154) for details on how to make the settings.



**4** Press the **OK** button.

The settings specified for all the images are saved and the DPOF setting method selection screen reappears.



- The number of copies specified in the [All Images] setting applies to all the images. Before printing, check that the number is correct.
- DPOF settings specified for single images are canceled when settings are made with [All Images].

## Memo

# **6 Recording and Playing Back Sound**

---

<b>Recording Sound (Voice Recording)</b> .....	<b>158</b>
<b>Adding a Voice Memo to Images</b> .....	<b>161</b>





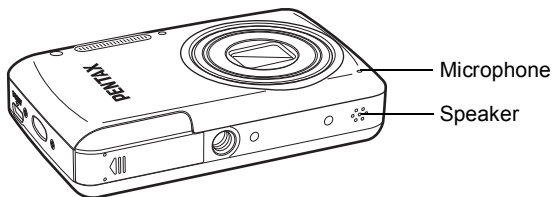

# Recording Sound (Voice Recording)

You can record sound with the camera. The microphone is located on the front of the camera. When recording sound, aim the camera at the sound source to obtain the best sound quality.



## Setting the Voice Recording Function

To use the Voice Recording function, assign it to the Green button first.

- 1 Press the MENU button in  mode.**  
The [ Rec. Mode] menu appears.
- 2 Use the four-way controller ( ) to select [Green Button].**
- 3 Press the four-way controller ().**  
A pull-down menu appears.
- 4 Use the four-way controller ( ) to select [Voice Recording] and press the OK button.**

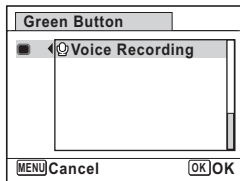

- 5 Press the MENU button.**  
The Voice Recording function is assigned to the Green button.



## Recording Sound

### 1 Press the Green button in mode.

The camera enters the Voice Recording mode. The remaining recordable time and the recording time of the current file appear on the display.

- 1 Recording time
- 2 Remaining recordable time



### 2 Press the shutter release button fully.

Recording starts. The self-timer lamp blinks during recording.

You can record sounds continuously for up to 18 hours.

When the Green button is pressed during recording, an index is added to the current sound file.



### 3 Press the shutter release button fully.

Recording stops.



- If you press and hold down the shutter release button for more than one second in Step 2, recording continues until you take your finger off the button. This is useful for recording short sound.
- Sound is saved in WAV (PCM) system monaural format.

## Playing Back Sound

You can play back the sound files you recorded in Voice Recording.

### 1 Press the button.

### 2 Use the four-way controller (◀▶) to choose the sound file to play back.

**Press the four-way controller (▲).**

Playback starts.

- 1 Total file recording time
- 2 Playback time

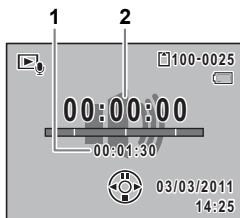
**Available operations during playback**

Zoom button towards the right (▲)	Increases the volume.
Zoom button towards the left (▼▼▼)	Reduces the volume.
Four-way controller (▲)	Pauses playback.
Four-way controller (◀)	(If there are no recorded indexes) Fast-reverses the sound. (If there are recorded indexes) Plays back starting from the previous index.
Four-way controller (▶)	(If there are no recorded indexes) Fast-forwards the sound. (If there are recorded indexes) Plays back starting from the next index.

**Available operations while playback is paused**

Four-way controller (▲)	Resumes playback.
Four-way controller (◀)	Rewinds approx. 5 seconds.
Four-way controller (▶)	Advances approx. 5 seconds.

**Press the four-way controller (▼).**

Playback stops.

# Adding a Voice Memo to Images

You can add a voice memo to your still pictures.

## Recording a Voice Memo

**1** In  mode, use the four-way controller (◀▶) to choose the still picture to which you want to add a voice memo.

**2** Press the four-way controller (▼).

The Playback Mode Palette appears.

**3** Use the four-way controller (▲▼◀▶) to select  (Voice Memo).



**4** Press the OK button.

Voice Memo recording starts, and the recording indicator blinks on the screen display during recording. Recording will continue until the built-in memory or SD Memory Card is full, or for up to 18 hours at maximum.

- 1 Recording
- 2 Remaining recordable time



**5** Press the OK button.

Recording stops.



- A voice memo cannot be added to the image that already has a voice memo. Delete the old voice memo (p.126) and record a new one.
- A voice memo cannot be added to protected images (p.129).

## Playing Back a Voice Memo

- 1** In  mode, use the four-way controller (◀▶) to choose the still picture with the voice memo that you want to play back.

 appears on images with a voice memo in single-image display.

- 2** Press the four-way controller (▲).

Playback starts.

### Available operations during playback

Zoom button towards the right (▲)	Increases the volume
Zoom button towards the left (▼)	Reduces the volume



- 3** Press the four-way controller (▼).

Playback stops.

To Delete the Sound from an Image  p.126

# 7 Settings

---

Camera Settings .....	164
-----------------------	-----

## Formatting an SD Memory Card

Formatting deletes all the data on the SD Memory Card.

Be sure to use this camera to format (initialize) an SD Memory Card that is unused or has been used on other cameras or digital devices.

If you select [Format] without an SD Memory Card inserted into the camera, the camera's built-in memory will be formatted instead.



- Do not remove the SD Memory Card during formatting as this may damage the card and render it unusable.
- Formatting deletes protected images and any data recorded on the card with a computer or any camera.
- SD Memory Cards formatted on a computer or device other than this camera cannot be used. Be sure to format the card with this camera.

### 1 Press the MENU button in mode.

The [ Setting] menu appears.

### 2 Use the four-way controller ( ) to select [Format].

### 3 Press the four-way controller () .

The [Format] screen appears.

### 4 Use the four-way controller ( ) to select [Format].

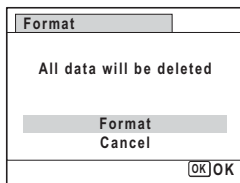

### 5 Press the OK button.

Formatting starts.

When formatting is completed, the camera returns to  mode.

## Changing the Sound Settings

You can adjust the volume of operation sounds and change the type of sound.

- 1 Press the MENU button in  mode.**

The [ Setting] menu appears.

- 2 Use the four-way controller ( ) to select [Sound].**

- 3 Press the four-way controller ().**

The [Sound] screen appears.

Subsequent steps vary depending on your selection.

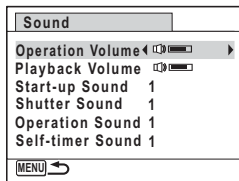

### To Change the Operation Volume/Playback Volume

- 4 Use the four-way controller ( ) to select [Operation Volume].**

- 5 Use the four-way controller ( ) to adjust the volume.**

Set the volume to  to mute the start-up sound, shutter sound, operation sound, and self-timer sound.



- 6 Change [Playback Volume] in the same way as in Steps 4 and 5.**

### To Change the Sound Type

- 4 Use the four-way controller ( ) to select [Start-up Sound].**

- 5 Press the four-way controller ().**

A pull-down menu appears.



- 6 Use the four-way controller ( ) to select the sound type.**

Choose from [1], [2], [3] or [Off].

- 7** Press the **OK** button.
- 8** Set **[Shutter Sound]**, **[Operation Sound]** and **[Self-timer Sound]** in the same way as in Steps 4 to 7.
- 9** Press the **MENU** button twice.  
The camera returns to  mode.

## Changing the Date and Time

You can change the initial date and time settings (p.46). Also, you can change the format in which the date appears on the camera.

- 1** Press the **MENU** button in  mode.  
The  [Setting] menu appears.
- 2** Use the four-way controller (**▲ ▼**) to select **[Date Adjustment]**.
- 3** Press the four-way controller (**▶**).  
The [Date Adjustment] screen appears.
- 4** Press the four-way controller (**▶**).  
The frame moves to [mm/dd/yy].  
Depending on the initial setting or previous setting, [dd/mm/yy] or [yy/mm/dd] may be displayed.

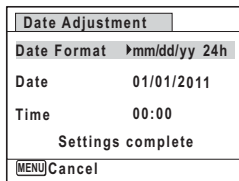

- 5** Use the four-way controller (**▲ ▼**) to choose the date format.  
Choose from [mm/dd/yy], [dd/mm/yy] or [yy/mm/dd].

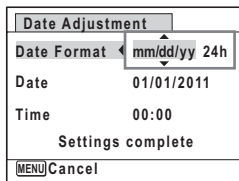



## 6 Press the four-way controller (▶).

The frame moves to [24h].

## 7 Use the four-way controller (▲▼) to select [24h] (24-hour display) or [12h] (12-hour display).

Date Adjustment	
Date Format	mm/dd/yy 24h
Date	01/01/2011
Time	00:00
Settings complete	
[MENU] Cancel	

## 8 Press the four-way controller (▶).

The frame returns to [Date Format].

## 9 Press the four-way controller (▼).

The frame moves to [Date].

## 10 Press the four-way controller (▶).

The frame moves to one of the following items depending on the date format set in Step 5.

Month for [mm/dd/yy]

Day for [dd/mm/yy]

Year for [yy/mm/dd]

Date Adjustment	
Date Format	mm/dd/yy 24h
Date	▶01/01/2011
Time	00:00
Settings complete	
[MENU] Cancel	

The following operations and screen use [mm/dd/yy] as an example. The operations are the same even if another date format has been selected.

## 11 Use the four-way controller (▲▼) to change the month.

Date Adjustment	
Date Format	mm/dd/yy 24h
Date	01/01/2011
Time	00:00
Settings complete	
[MENU] Cancel	

## 12 Press the four-way controller (▶).

The frame moves to the day field. Use the four-way controller (▲▼) to change the day. After changing the day, change the year in the same manner.

### 13 Change the time in the same way as in Steps 8 to 12.

If you select [12h] in Step 7, the camera automatically switches the display between am and pm corresponding to the time.

### 14 Press the four-way controller (▼) to select [Settings complete].

Date Adjustment	
Date Format	mm/dd/yy 24h
Date	01/01/2011
Time	00:00
Settings complete	
MENU) Cancel	(OK) OK

### 15 Press the OK button.

The date and time settings are saved.



When you press the **OK** button in Step 15, the camera clock is reset to 0 seconds. To set the exact time, press the **OK** button when the time signal (on the TV, radio, etc.) reaches 0 seconds.

## Setting the World Time

The date and time selected in “Setting the Date and Time” (p.46) and “Changing the Date and Time” (p.166) serve as the Hometown date and time. If you set the Destination city using the World Time function, you can display the Destination date and time when taking pictures in a different time zone.

### To Set the Destination

#### 1 Press the MENU button in mode.

The [ Setting] menu appears.

#### 2 Use the four-way controller (▲▼) to select [World Time].

#### 3 Press the four-way controller (▶).

The [World Time] screen appears.

- 4** Use the four-way controller (▲▼) to select [→ Destination].

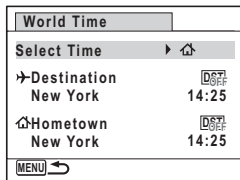

- 5** Press the four-way controller (▶).

The [→ Destination] screen appears. The city that is currently selected blinks on the map.

- 6** Use the four-way controller (◀▶) to change the Destination city.

The current time, location and time difference of the selected city appear.

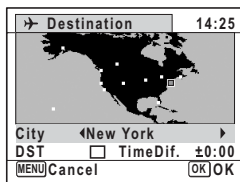

- 7** Use the four-way controller (▲▼) to select [DST].

- 8** Use the four-way controller (◀▶) to select  (On) or  (Off).

Select  if the Destination city uses daylight saving time.

- 9** Press the OK button.

The settings are saved and the [World Time] screen reappears.

- 10** Press the MENU button twice.

The camera returns to capture status with the current setting.



Select [↕ Hometown] in Step 4 to set the city and DST setting for the Hometown city.

## To Display the Time of the Destination (Select Time)

### 1 Press the MENU button in mode.

The [Setting] menu appears.

### 2 Use the four-way controller (▲▼) to select [World Time].

### 3 Press the four-way controller (▶).

The [World Time] screen appears.

### 4 Use the four-way controller (▲▼) to select [Select Time].

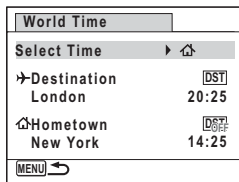

### 5 Press the four-way controller (▶).

A pull-down menu appears.

### 6 Use the four-way controller (▲▼) to select or .

 Displays the time of the Destination city

 Displays the time of the Hometown city

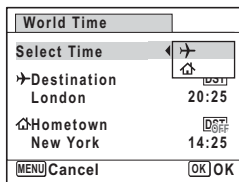



### 7 Press the OK button.

The setting is saved.

### 8 Press the MENU button twice.

The camera returns to  mode.

When  (Destination) is selected in Step 6, the  icon appears on the display to indicate that the Destination date and time are displayed in  mode.



## Changing the Display Language

You can change the language in which the menus, error messages, etc. are displayed.

The camera supports the following languages: English, French, German, Spanish, Portuguese, Italian, Dutch, Japanese, Danish, Swedish, Finnish, Polish, Czech, Hungarian, Turkish, Greek, Russian, Thai, Korean, Traditional Chinese and Simplified Chinese.

### 1 Press the MENU button in mode.

The [ Setting] menu appears.

### 2 Use the four-way controller ( ) to select [Language/言語].

### 3 Press the four-way controller () .

The [Language/言語] screen appears.

### 4 Use the four-way controller ( ) to select the desired language.

Language/言語		
English	日本語	Türkçe
Français	Dansk	Ελληνικό
Deutsch	Svenska	Русский
Español	Suomi	ไทย
Português	Polski	한국어
Italiano	Čeština	中文繁體
Nederlands	Magyar	中文简体
[MENU] Cancel		[OK] OK

### 5 Press the OK button.

The menus and messages are displayed in the selected language.

## Changing the Naming System of the Folder

You can change the naming system of the folder for storing images. When the naming system is set to [Date], pictures are saved in separate folders by the date they were taken.

PENTX	xxxPENTX (where xxx is the 3-digit folder number)
Date	xxx_mmdd (3-digit folder number_month day) * xxx_ddmm (3-digit folder number_day month) when the [Date Format] is set to [dd/mm/yy]

Taken with the folder name setting [PENTX].  
(e.g. September 25)

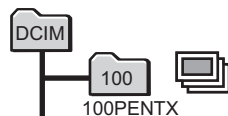

Taken with the folder name setting [Date].  
(e.g. September 25)

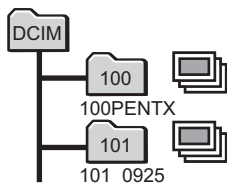

Next time, taken with the folder name setting [Date] again.  
(e.g. October 1)

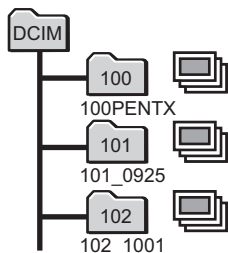







7

Settings









- Up to 900 folders can be created.
- Up to 9999 images or sound files can be saved in a folder.

- 1 Press the MENU button in  mode.**  
The [ Setting] menu appears.
- 2 Use the four-way controller ( ) to select [Folder Name].**
- 3 Press the four-way controller ().**  
A pull-down menu appears.
- 4 Use the four-way controller ( ) to select [PENTX] or [Date].**
- 5 Press the OK button.**  
The setting is saved.

## Changing the Video Output Format

When you take pictures and/or play them back with the camera connected to AV equipment, select an appropriate video output format (NTSC or PAL).

- 1 Press the MENU button in  mode.**  
The [ Setting] menu appears.
- 2 Use the four-way controller ( ) to select [Video Out].**
- 3 Press the four-way controller ().**  
A pull-down menu appears.
- 4 Use the four-way controller ( ) to select a video output format.**  
Choose the video output format to match the input format of the AV equipment.

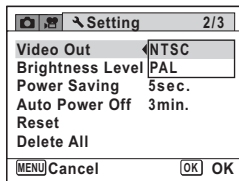

## 5 Press the OK button.

The setting is saved.



Depending on the country or region, images and sound files may fail to be played back if the video output format is set differently from the one in use there. If this happens, change the video output format setting.

Connecting the Camera to AV Equipment p.132  
Video Output Format of Each City p.207

## Adjusting the Brightness of the Display

You can adjust the brightness of the display.

### 1 Press the MENU button in mode.

The [ Setting] menu appears.

### 2 Use the four-way controller ( ) to select [Brightness Level].

### 3 Use the four-way controller ( ) to adjust the brightness.

- Dark
- Normal
- Bright

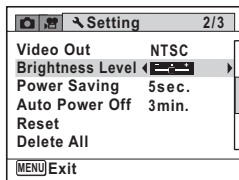

### 4 Press the MENU button.

The camera returns to mode.

The display appears with the set brightness.



## Using the Power Saving Function

You can save battery power by setting the display to dim automatically when no operation is performed for a fixed time. After the power saving function has been activated, the display returns to the ordinary brightness if any button is pressed.

### 1 Press the **MENU** button in mode.

The [ Setting] menu appears.

### 2 Use the four-way controller ( ) to select [**Power Saving**].

### 3 Press the four-way controller ().

A pull-down menu appears.

### 4 Use the four-way controller ( ) to select the time until the camera enters the power saving mode.

Choose from [2min.], [1min.], [30sec.], [15sec.], [5sec.] or [Off].

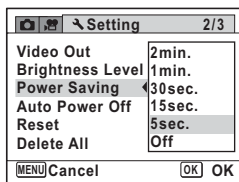

### 5 Press the **OK** button.







The setting is saved.



- Power Saving does not function in the following situations:
  - In the playback mode
  - While recording a movie
  - While the camera is connected to a computer
  - While a menu is being displayed
- When no operation is performed after the camera is turned on, the Power Saving function is activated only after 15 seconds elapse even if [5sec.] is set.

## Setting the Auto Power Off Function

You can set the camera to turn off automatically when no operation is performed for a fixed time.

- 1 Press the MENU button in  mode.**  
The [ Setting] menu appears.
- 2 Use the four-way controller ( ) to select [Auto Power Off].**
- 3 Press the four-way controller ().**  
A pull-down menu appears.
- 4 Use the four-way controller ( ) to select the time until the camera turns off automatically.**  
Choose from [5min.], [3min.] or [Off].
- 5 Press the OK button.**  
The setting is saved.

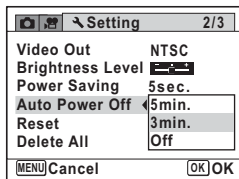

Auto Power Off does not function in the following situations:

- While taking pictures in the Continuous Shooting mode
- While recording a movie
- During a slideshow or movie/sound playback
- While the camera is connected to a computer

## Changing the Start-up Screen

You can choose the start-up screen displayed when the camera is turned on.

You can choose any of the following images as the start-up screen:

- The Guide Display Start-up Screen showing a guide for the shooting modes and buttons
- PENTAX logo
- One of your own images (compatible images only)

### 1 In mode, press the four-way controller (▼).

The Playback Mode Palette appears.

### 2 Use the four-way controller (▲▼◀▶) to select (Start-up Screen).



### 3 Press the OK button.

The image selection screen appears.

### 4 Use the four-way controller (◀▶) to choose the image for the start-up screen.

Only images available for the start-up screen are displayed. You can also choose the PENTAX logo screen or the Guide Display Start-up screen already stored in the camera.



### 5 Press the OK button.

The start-up screen is set.





- Once the start-up screen has been set, it will not be deleted even if the original image is deleted or the SD Memory Card is formatted.
- The start-up screen is not displayed when set to [Off].
- The start-up screen is not displayed when the camera starts up in the playback mode.

## Correcting Defective Pixels in the CCD Sensor (Pixel Mapping)

Pixel Mapping is a function for mapping out and correcting defective pixels in the CCD sensor. Run the Pixel Mapping function if image dots always seem to be defective in the same place.

- 1 Press the MENU button in  mode, and press the four-way controller (▶).**

The [ Setting] menu appears.

[Pixel Mapping] cannot be selected when the MENU button is pressed in  mode.

- 2 Use the four-way controller (▲ ▼) to select [Pixel Mapping].**

- 3 Press the four-way controller (▶).**

The [Pixel Mapping] screen appears.

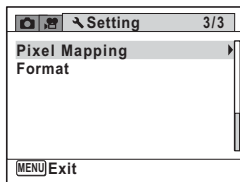

- 4 Use the four-way controller (▲ ▼) to select [Pixel Mapping].**

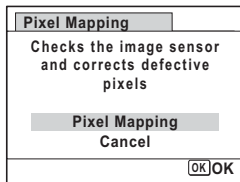

- 5 Press the OK button.**

Defective pixels are mapped and corrected.



When the battery level is low, [Not enough battery power remaining to activate Pixel Mapping] is displayed on the monitor. Charge the battery or replace it with a fully charged battery.

## Resetting to Default Settings (Reset)

You can reset the camera settings to their defaults. Refer to “Default Settings” (p.202) for the reset settings.

**1** Press the **MENU** button in  mode.

The [ Setting] menu appears.

**2** Use the four-way controller (**▲ ▼**) to select [**Reset**].

**3** Press the four-way controller (**▶**).

The [Reset] screen appears.

**4** Use the four-way controller (**▲ ▼**) to select [**Reset**].

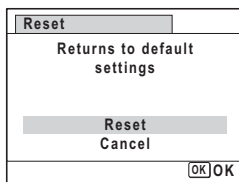

**5** Press the **OK** button.

The settings return to the defaults.



The following settings are not affected by resetting:

- Date Adjustment
- World Time
- Language/言語
- Video Out

## Memo

# **8** Connecting to a Computer

---

<b>Connecting to a Computer .....</b>	<b>182</b>
<b>Using the Provided Software .....</b>	<b>186</b>







# Connecting to a Computer

## Setting the USB Connection Mode

Set the device to which the camera is connected with the USB cable.

**Caution**

Make sure to set the USB Connection mode before connecting your camera to a computer. You cannot perform the following setting if your camera is connected to a computer with the USB cable.

- 1 Turn your camera on.**
- 2 Press the MENU button in  mode.**  
The [ Setting] menu appears.
- 3 Use the four-way controller ( ) to select [USB Connection].**
- 4 Press the four-way controller ().**  
A pull-down menu appears.
- 5 Use the four-way controller ( ) to select [MSC].**

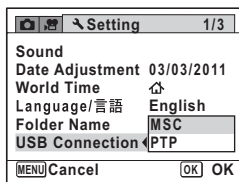

- 6 Press the OK button.**  
The setting is saved.



### **MSC (Mass Storage Class)**

A general-purpose driver program that handles devices connected to the computer via USB as a memory device. Also indicates a standard for controlling USB devices with this driver.

By simply connecting a device that supports USB Mass Storage Class, you can copy, read, and write files from a computer without installing a dedicated driver.

### **PTP (Picture Transfer Protocol)**

A protocol that allows transfer of digital images and control of digital cameras via USB, standardized as ISO 15740.

You can transfer image data between devices that support PTP without installing a device driver.

Unless otherwise specified, select MSC when connecting the Optio S1 to a computer.

## Connecting the Camera and the Computer

Connect your camera to the computer using the provided USB cable (I-USB116).

- 1 Turn the computer on.**
- 2 Turn your camera off.**
- 3 Connect your camera to the computer using the USB cable.**

Face the ➡ mark on the USB cable towards the ◀ mark on the camera, and connect the cable to the PC/AV terminal.

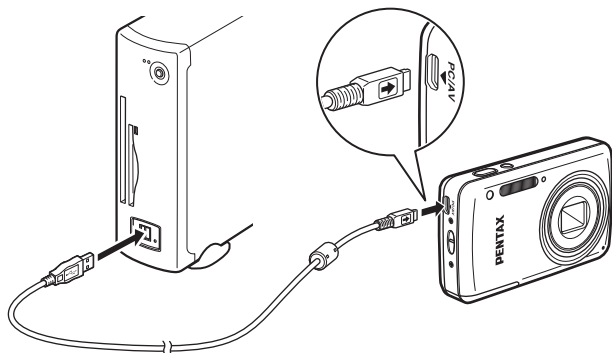

- 4 Turn your camera on.**

The camera is recognized by the computer.



If the battery runs out of power while images are being transmitted to the computer, the image data may be lost or damaged. Charge the battery fully before connecting your camera to the computer.



- The self-timer lamp blinks while the camera is connected to a computer.
- If there is no SD Memory Card in the camera, the images stored in the built-in memory can be viewed with a computer.
- For information on system requirements, refer to p.186.

## Disconnecting the Camera from the Computer

When the camera is being used by an application such as MediaImpression, it cannot be disconnected until the application is closed.

### Windows

- 1 Click the  [Safely Remove Hardware] icon in the task bar located at the bottom-right corner of the desktop.
- 2 Click [Eject Optio S1].  
The message appears.  

- 3 Disconnect the USB cable from the Windows PC and your camera.

### Macintosh

- 1 Drag [NO NAME] on the desktop to the trash.  
If the SD Memory Card has a volume label, drag the icon of that name to the trash.
- 2 Disconnect the USB cable from the Macintosh and your camera.



The camera will automatically switch to the playback mode when the USB cable is disconnected from the camera or the computer.

# Using the Provided Software

The following software is included in the provided CD-ROM (S-SW116).

## Image viewing/managing/editing software

“Medialmpression 3.0 for PENTAX” (for Windows)

“Medialmpression 2.1 for PENTAX” (for Macintosh)

Languages: English, French, German, Spanish, Portuguese, Italian, Dutch, Swedish, Russian, Korean, Chinese (traditional and simplified), Japanese



You can edit movies when using the “Medialmpression 3.0 for PENTAX” (for Windows)

## System Requirements

The following system requirements must be met for you to fully enjoy the images and movies captured with the camera on a computer.



The following lists the minimum system requirements for playing back and editing movies. Operation is not guaranteed on all computers meeting the system requirements.

### Windows

OS	Windows XP (SP3), Windows Vista or Windows 7 • The OS must be preinstalled and updated to the latest version.
CPU	Pentium 4 1.6 GHz or equivalent AMD Athlon (Intel Core 2 Duo 2.0 GHz or equivalent AMD Athlon X2 or higher processor recommended)
Memory	512 MB or more (1 GB or more recommended)
Hard Disk Space	300 MB or more
Others	CD-ROM drive USB port as standard equipment 1024 × 768 pixels, 16-bit color monitor or greater



Windows 95, Windows 98, Windows 98SE, Windows Me, Windows NT and Windows 2000 are not supported.

## Macintosh

OS	Mac OS X (Ver.10.3.9, 10.4, 10.5, 10.6) <ul style="list-style-type: none"><li>• The OS must be preinstalled and updated to the latest version.</li></ul>
CPU	PowerPC G4 800 MHz processor or equivalent CPU (Intel Core Duo or higher processor recommended)
Memory	512 MB or more (1 GB or more recommended)
Hard Disk Space	300 MB or more
Others	CD-ROM drive USB port as standard equipment 1024 × 768 pixels, 16-bit color monitor or greater

## Installing the Software

Install the image viewing/managing/editing software “MediaImpression”.



- Make sure the computer meets the system requirements before installing the software.
- When multiple accounts have been set up in the computer, log on with an account that has administrative rights before installing the software.

## Windows

This section outlines installation steps in Windows 7 as an example.

- 1 Turn your Windows PC on.**
- 2 Insert the provided CD-ROM into the CD/DVD drive.**  
If the installation screen appears, go to Step 5.

**3** Click [Computer] in the Start menu.

**4** Double-click the CD/DVD drive (S-SW116) icon.  
The installation screen appears.

**5** Click [MediaImpression 3.0 for PENTAX].



**6** Choose a language in the “Choose Setup Language” screen and click [OK].

The setup screen appears. Follow the on-screen guidance and install the software.

**7** Select the file format to use and click [Next].

All files in the checked format will open with MediaImpression. Remove the check to open the file using another application.

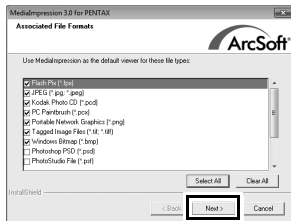

**8** Click [Finish].

Installation is complete.  
Remove the CD-ROM and reboot the computer.

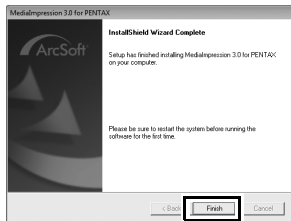

- 1** Turn your Macintosh on.
- 2** Insert the provided CD-ROM into the CD/DVD drive.
- 3** Double-click the CD-ROM (S-SW116) icon.
- 4** Double-click the [Pentax Software Installer] icon.  
The installation screen appears.
- 5** Click [MedialImpression 2.1 for PENTAX].

The setup screen appears. Follow the on-screen guidance and install the software.



- 6** Click [Close].  
Installation is complete.

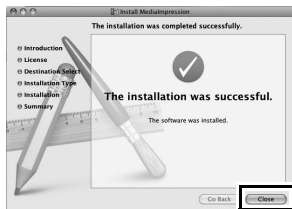

- 7** Click [Exit] on the installation screen.  
The window is closed.

## Product Registration on the Internet

In order to better serve you, we request that you complete the product registration.

If the computer is connected to the Internet, please click [Product Registration] on the installation screen. The world map screen shown on the right for Internet Product Registration is displayed. Click the displayed country or region and then follow the instructions to register your product.

Only customers in countries and regions displayed on the software installation screen can register their products on the Internet Product Registration.

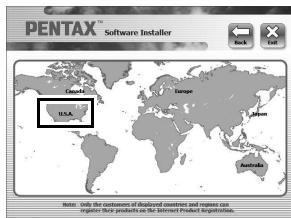

## Using MediaImpression on Windows

### 1 Connect your camera to the computer.

Refer to Steps 2 to 4 on p.184 for details.  
The [AutoPlay] screen appears.

### 2 Click [Import media files to local disk].

MediaImpression starts and the Import screen appears.





### When the [AutoPlay] screen does not appear

- 1 Double-click the [MedialImpression 3.0 for PENTAX] icon on the desktop.
- 2 Click [PhotoImpression].
- 3 Click [Import].

### 3 Click the folder icon next to [Destination Folder] and specify the destination location.

To import all images, proceed to Step 5.

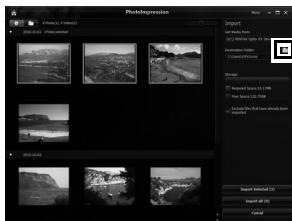

### 4 Select an image to import.

To select multiple images, choose the images while pressing the Ctrl key.

### 5 Click [Import Selected] or [Import All].

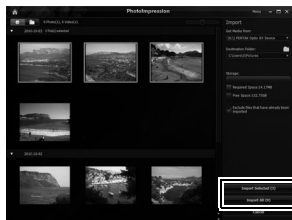

When a message appears after import is complete, click [Done].

The images are imported to the computer and the Album screen appears.

You can enlarge the display size of an image or edit an image in the Album screen.



You can find more information on how to use MedialImpression by using the help pages. Select [Help] in [Menu] at the top right of the screen.

## Using MediaImpression on Macintosh

### 1 Connect the camera to your Macintosh.

Refer to Steps 2 to 4 on p.184 for details.

### 2 Double-click the [MediaImpression 2.1 for PENTAX] icon in the [Applications] folder.

MediaImpression 2.1 for PENTAX starts and the start page appears.



MediaImpression 2.1 for PENTAX.app

### 3 Click [Import].

The Import screen appears.



### 4 Select an image to import.

To select multiple images, choose the images while pressing the Ctrl key.

To specify the destination location, click the folder icon.

If any of the "Import Options" are checked, marks will appear on the images that were imported.

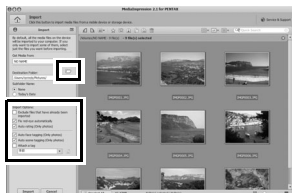

## 5 Click [Import].

The images are imported to the computer and the Media Browser screen appears. When a message appears after import is complete, click [Done].

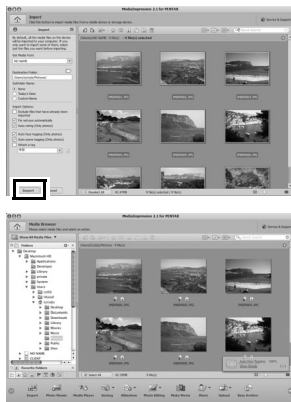

- If the images from the camera are not displayed in the Import screen, select [NO NAME] (or the volume label name) in [Get Media from].
- You can find more information on how to use MediaImpression by using the help pages. Select [ArcSoft MediaImpression Help] in [Help] on the menu bar.



# 9 Appendix

---

<b>Functions Available for Each Shooting Mode .....</b>	<b>196</b>
<b>Messages .....</b>	<b>198</b>
<b>Troubleshooting .....</b>	<b>200</b>
<b>Default Settings .....</b>	<b>202</b>
<b>List of World Time Cities .....</b>	<b>207</b>
<b>Optional Accessories .....</b>	<b>208</b>
<b>Main Specifications .....</b>	<b>209</b>
<b>WARRANTY POLICY .....</b>	<b>213</b>
<b>Index .....</b>	<b>219</b>

# Functions Available for Each Shooting Mode

✓: Can be set.

×: Cannot be set.

Function		Shooting Mode				
Zoom button	Zoom operation	✓	✓	✓*1	✓	✓
Flash Mode	(Auto)	✓	✓	✓	×	✓
	(Flash Off)	✓	✓	✓	✓	✓
	(Flash On)	✓	✓	×	✓	✓
	(Auto + Red-eye)	✓	×	×	×	✓
	(Flash On + Red-eye)	✓	✓	×	✓	✓
Drive Mode	(Standard)	✓	✓	✓	✓	✓
	(Self-timer)	✓	✓	✓	✓	✓
	(2 sec. Self-timer)	✓	✓	✓	✓	✓
	(Continuous Shooting)	✓	✓	×	✓	✓
	(Burst Shooting)	✓	✓	×	✓	✓
	(Remote Control)	✓	✓	×	✓	✓
	(0-sec Remote Control)	✓	✓	×	✓	✓
Focus Mode	<b>AF</b> (Standard)	✓	✓	✓	✓	✓
	(Macro)	✓	✓	✓	✓	✓
	(Super Macro)	✓	✓	×	✓	✓
	<b>PF</b> (Pan Focus)	✓	✓	✓	✓	✓
	(Infinity)	✓	✓	×	✓	✓
	<b>MF</b> (Manual Focus)	✓	✓	×	✓	✓
[📷 Rec. Mode] menu	Recorded Pixels	✓	✓	×	✓	✓
	White Balance	×	✓	×	✓	×
	Focusing Area	×	✓	×	✓	✓
	AE Metering	×	✓	×	✓	×
	Sensitivity	✓	✓	×	✓	✓
	EV Compensation	×	✓	×	✓	✓
	D-Range Setting	×	✓	×	✓	✓
	Shake Reduction	✓	✓	×	✓	✓
	Face Detection	✓*17	✓	×	✓	✓*17
	Blink Detection	✓	✓	×	✓	✓
	Sharpness	×	✓	×	✓	×
	Saturation	×	✓	×	✓	×
	Contrast	×	✓	×	✓	×
	Date Imprint	✓	✓	×	✓	✓

\*1 Intelligent Zoom is not available

\*2 Only optical zoom is available

\*3 Fixed at (Flash Off)

\*4 Fixed at (Infinity)

\*5 Fixed at

\*6 Set in the [📷 Movie] menu

\*7 Fixed at

\*8 Fixed at in mode

Fixed at in mode

Shooting menu items not listed in this chart can be set in any shooting mode except for Green Mode. However, these settings may not function properly in certain shooting modes and setting conditions even if they can be selected. For further information, please refer to the pages listed below.

Shooting Mode							Function	Page	
✓	✓*2	✓	✓	✓	✓*1	Zoom operation	Zoom button	p.73	
✓	✓	x	✓	✓	x	(Auto)	Flash Mode	p.88	
✓	✓	x*3	✓	✓	x*3	(Flash Off)			
✓	✓	x	✓	✓	x	(Flash On)			
✓	✓	x	✓	✓	x	(Auto + Red-eye)			
✓	✓	x	✓	✓	x	(Flash On + Red-eye)			
✓	✓	✓	✓	✓	✓	(Standard)	Drive Mode	—	
✓	✓	✓	✓	✓	✓	(Self-timer)			
✓	✓	✓	✓	✓	✓	(2 sec. Self-timer)			
✓	✓	x	x	x	x	(Continuous Shooting)			
✓	✓	x	x	x	x	(Burst Shooting)			
✓	✓	✓	✓	✓	✓	(Remote Control)			
✓	✓	✓	✓	✓	✓	(0-sec Remote Control)	p.86		
✓	✓	x	✓	✓	✓	<b>AF</b> (Standard)	Focus Mode	p.89	
✓	✓	x	✓	✓	✓	(Macro)			
✓	✓	x	✓	✓	✓	(Super Macro)			
✓	✓	x	✓	✓	✓	<b>PF</b> (Pan Focus)			
✓	✓	✓*4	✓	✓	✓	(Infinity)			
✓	✓	x	✓	✓	✓	<b>MF</b> (Manual Focus)	[Rec. Mode] menu	p.92	
✓	x*7	✓	x*8	✓	✓*6	Recorded Pixels			p.96
x*9	✓	x*9	✓	✓	✓	White Balance			p.91
✓	✓	x*10	✓	✓	✓	Focusing Area			p.98
x*11	✓	x*11	✓	✓	x*11	AE Metering			p.99
✓	x*12	x*13	✓	✓	x*12	Sensitivity			p.94
✓	✓	✓	✓	✓	✓	EV Compensation			p.95
✓	✓	✓	✓	✓	✓	D-Range Setting			p.102
✓	✓	x*15	✓	✓	✓*16	Shake Reduction			p.100
✓	✓	✓	✓	✓	✓	Face Detection			p.104
✓	✓	✓	✓	✓	✓	Blink Detection			p.105
x	✓	x	✓	✓	✓	Sharpness			p.105
x	✓	x	✓	✓	✓	Saturation			p.106
x	✓	x	✓	✓	✓	Contrast			p.106
✓	✓	✓	✓	✓	x	Date Imprint			

\*9 Fixed at **AWB**

\*10 Fixed at [ ] (Multiple)

\*11 Fixed at [ ] (Multi-segment)

\*12 Fixed at [Auto]

\*13 The sensitivity is fixed at the minimum value

\*14 Fixed at ±0.0

\*15 Fixed at [Off]/□ (Off)

\*16 Set [Movie SR] in the [Movie] menu

\*17 [Off] is not available

\*18 Fixed at [On]/☑ (On)

\*19 Fixed at the normal setting

# Messages

Messages such as the following may appear on the display during camera operation.







Message	Description
Battery depleted	The battery is exhausted. Charge the battery using the power adapter D-PA116 (p.33).
Memory card full	The SD Memory Card is full and no more images can be saved. Insert a new SD Memory Card or delete unwanted images (p.36, p.126). Change the number of recorded pixels of recorded images and try again (p.136).
Built-in memory full	Displayed if the built-in memory is full when saving a file.
Memory card error	Shooting and playback are impossible due to a problem with the SD Memory Card. You may be able to display or copy the images on the card using a computer.
The built-in memory is not formatted	The data within the built-in memory is damaged. Format the built-in memory.
Card is not formatted	The SD Memory Card you have inserted is unformatted or has been formatted on a computer or other device and is not compatible with this camera. Format the SD Memory Card in the camera (p.164).
Card is locked	The SD Memory Card is write-protected (p.38).
Compression error	This message appears when the camera fails to compress an image. Change the number of recorded pixels of the image and try shooting or saving it again.
No image/sound	There are no image/sound files on the SD Memory Card or in the built-in memory.
Movie recording stopped	This message appears when the internal temperature of the camera has exceeded normal operating limits while recording a movie.
The camera will turn off to prevent damage from overheating	The camera turned off because it has overheated. Wait until it cools down and then turn it back on.
Deleting	This message appears while deleting an image or sound file.
Camera cannot play this image and sound	You are trying to play back an image or sound in a format not supported by this camera. You may be able to play it back on another brand of camera or on your computer.



Message	Description
Image folder cannot be created	The largest file number (9999) has been assigned to an image in the largest folder number (999) and no more images can be saved. Insert a new SD Memory Card or format the card (p.164).
Protected	The image or sound file you are trying to delete is protected (p.129).
Data being recorded	Displayed when you try to switch to  mode while an image is still being recorded, or when an image is being saved or a setting is being changed. It disappears after the image is recorded or the setting is changed.
Data being processed	Displayed when the camera takes more than five seconds to display an image due to image processing, or when the SD Memory Card or the built-in memory is being formatted.
No image to be processed	Displayed when there are no images or sound files.
This image/sound cannot be processed	Displayed for files that cannot be processed.
No card in the camera	Displayed when no SD Memory Card is inserted.
The built-in memory is not enough to copy images/sounds	Displayed when there is insufficient built-in memory to perform copying.
Cannot process correctly	Displayed when Red-eye Compensation processing fails.
Not enough battery power remaining to activate Pixel Mapping	Appears during pixel mapping if the battery level is insufficient. Charge the battery using the power adapter D-PA116, or replace the battery with a fully charged one. (p.33)

# Troubleshooting

Problem	Cause	Remedy
The camera will not turn on	The battery is not installed	Check if a battery is installed.
	The battery is installed incorrectly	Check orientation of the battery. Reinsert the battery with the label facing the display (p.31).
	The battery is exhausted	Charge the battery.
No image appears on the display	The camera is connected to a computer	The display is off when the camera is connected to a computer.
	The camera is connected to a TV	The display is off when the camera is connected to a TV.
The display is hard to see	The brightness level of the display is set too dark	Adjust the brightness level in [Brightness Level] in the [Setting] menu (p.174).
	Power Saving function is activated	When the Power Saving function is activated, the display automatically darkens after a certain amount of time. Press any button to return to the normal brightness level. Select [Off] in [Power Saving] in the [Setting] menu to turn the Power Saving function off (p.175).
The shutter will not release	The flash is charging	Pictures cannot be taken while the flash is charging. Wait until charging is finished.
	There is no available space on the SD Memory Card or in the built-in memory	Insert an SD Memory Card with available space or delete unwanted images (p.36, p.126).
	Recording	Wait until recording is finished.
The picture is dark when using the flash	The subject is too far away in a dark environment, such as a night scene	The picture becomes dark if the subject is too far away. Take pictures within the specified flash range.

Problem	Cause	Remedy
The subject is not in focus	The subject is difficult to focus on with autofocus	The camera may have difficulty in focusing on such subjects as: low contrast subjects (a white wall, a blue sky, etc.), dark subjects, finely-patterned objects, rapidly-moving objects. It is also difficult to get proper focus when shooting through a window or a net. Try shooting using the focus lock (p.66), or adjust the focus manually (Manual Focus) (p.90).
	The subject is not in the focusing area	Locate the desired subject in the focus frame (focusing area) in the center of the display. If it is difficult to do so, first lock the focus on the desired subject (focus lock), and then move the camera to recompose.
The flash does not discharge	The flash mode is set to 	Set to  (Auto) or  (Flash On) (p.88).
	The drive mode is set to  or  The focus mode is set to  The shooting mode is set to  , or while recording a movie	The flash does not discharge in these modes.



Very occasionally, static electricity may cause camera malfunction. In this case, remove the battery and install it again. If the camera then works properly, normal condition is restored and you can continue using the camera.

# Default Settings

The table below lists the factory default settings.

The meaning of the indications for menu items with a default setting is explained below.

## Last Memory Setting

Yes : The current setting (last memory) is saved when the camera is turned off.

No : The setting returns to the default setting when the camera is turned off.

\* : The last memory setting depends on the [Memory] setting (p.113).

— : N/A

## Reset Setting



Yes : The setting returns to the default setting with the Reset function (p.179).

No : The setting is saved even after reset.

— : N/A

## ● [📷 Rec. Mode] Menu Items



Item	Default Setting	Last Memory Setting	Reset Setting	Page
Recorded Pixels	(4288×3216)	Yes	Yes	p.92
White Balance	<b>AWB</b> (Auto)	*	Yes	p.96
Focusing Area	[ ] (Multiple)	Yes	Yes	p.91
AE Metering	(Multi-segment)	*	Yes	p.98
Sensitivity	Auto	*	Yes	p.99
EV Compensation	±0.0	*	Yes	p.94
D-Range Setting	Highlight Correction <input type="checkbox"/> (Off)	Yes	Yes	p.95
	Shadow Correction <input type="checkbox"/> (Off)	Yes	Yes	
Shake Reduction	<input checked="" type="checkbox"/> (On)	Yes	Yes	p.102
Face Detection	On	*	Yes	p.100
Blink Detection	<input checked="" type="checkbox"/> (On)	Yes	Yes	
Digital Zoom	<input checked="" type="checkbox"/> (On)	*	Yes	p.74
Instant Review	<input checked="" type="checkbox"/> (On)	Yes	Yes	p.103

Item		Default Setting	Last Memory Setting	Reset Setting	Page
Memory	Flash Mode	<input checked="" type="checkbox"/> (On)	Yes	Yes	p.88
	Drive Mode	<input type="checkbox"/> (Off)	Yes	Yes	p.84 p.85
	Focus Mode	<input type="checkbox"/> (Off)	Yes	Yes	p.89
	Zoom Position	<input type="checkbox"/> (Off)	Yes	Yes	p.73
	MF Position	<input type="checkbox"/> (Off)	Yes	Yes	p.90
	White Balance	<input type="checkbox"/> (Off)	Yes	Yes	p.96
	Sensitivity	<input type="checkbox"/> (Off)	Yes	Yes	p.99
	EV Compensation	<input type="checkbox"/> (Off)	Yes	Yes	p.94
	AE Metering	<input type="checkbox"/> (Off)	Yes	Yes	p.98
	Face Detection	<input type="checkbox"/> (Off)	Yes	Yes	p.100
	Digital Zoom	<input checked="" type="checkbox"/> (On)	Yes	Yes	p.74
	DISPLAY	<input type="checkbox"/> (Off)	Yes	Yes	p.20
File No.	<input checked="" type="checkbox"/> (On)	Yes	Yes	—	
Green Button	Green Mode	Yes	Yes	p.107	
Sharpness	 (Normal)	Yes	Yes	p.104	
Saturation	 (Normal)	Yes	Yes	p.105	
Contrast	 (Normal)	Yes	Yes	p.105	
Date Imprint	Off	Yes	Yes	p.106	

### ● [Movie] Menu Items

Item	Default Setting	Last Memory Setting	Reset Setting	Page
Recorded Pixels	 (1280×720/30 fps)	Yes	Yes	p.111
Movie SR	<input checked="" type="checkbox"/> (On)	Yes	Yes	p.112











● [  Setting ] Menu Items

Item		Default Setting	Last Memory Setting	Reset Setting	Page
Sound	Operation Volume	3	Yes	Yes	p.165
	Playback Volume	3	Yes	Yes	
	Start-up Sound	1	Yes	Yes	
	Shutter Sound	1	Yes	Yes	
	Operation Sound	1	Yes	Yes	
	Self-timer Sound	1	Yes	Yes	
Date Adjustment	Date Format (date)	According to the initial setting	Yes	No	p.46 p.166
	Date Format (time)	24h	Yes	No	
	Date	1/1/2011	Yes	No	
	Time	According to the initial setting	Yes	No	
World Time	Select Time	 Hometown	Yes	Yes	p.168
	Destination (City)	According to the initial setting	Yes	No	
	Destination (DST)	<input type="checkbox"/> (Off)	Yes	No	
	Hometown (City)	According to the initial setting	Yes	No	
	Hometown (DST)	<input type="checkbox"/> (Off)	Yes	No	
Language/言語		According to the initial setting	Yes	No	p.42 p.171
Folder Name		Date	Yes	Yes	p.172
USB Connection		MSC	Yes	Yes	p.182
Video Out		According to the initial setting	Yes	No	p.173
Brightness Level		 (Normal)	Yes	Yes	p.174
Power Saving		5 sec.	Yes	Yes	p.175
Auto Power Off		3 min.	Yes	Yes	p.176
Reset		Cancel	—	—	p.179
Delete All		Cancel	—	—	p.128
Pixel Mapping		Cancel	—	—	p.178
Format		Cancel	—	—	p.164

## ● Playback Mode Palette Items

Item		Default Setting	Last Memory Setting	Reset Setting	Page
Slideshow	Interval	3 sec.	Yes	Yes	p.121
	Screen Effect	Wipe	Yes	Yes	
	Sound Effect	<input checked="" type="checkbox"/> (On)	Yes	Yes	
Image Rotation		Normal	—	—	p.124
Miniature Filter		 (Blurring of the top and bottom)	No	No	p.138
HDR Filter		—	—	—	p.138
Digital Filter		B&W	No	—	p.140
Frame Composite		Default1	Yes	Yes	p.145
Red-eye Compensation		—	—	—	p.144
Movie Editing	Save as Still Image	—	—	—	p.148
	Divide Movies	—	—	—	
Resize	Recorded Pixels	Depending on the picture taken	—	—	p.136
Cropping		Depending on the picture taken	—	—	p.137
Image/Sound Copy		Built-in memory → SD Memory Card	—	—	p.150
Voice Memo		—	—	—	p.161
Protect	Single Image/ Sound	Depending on the recorded image/sound	—	—	p.129
	All Images/Sounds	Depending on the recorded image/sound	—	—	
DPOF	Single Image	Copies: 0	—	—	p.153
	All Images	Date: <input type="checkbox"/> (Off)	—	—	
Start-up Screen		Off	Yes	Yes	p.177

## ● Key Operation

Item	Function	Default Setting	Last Memory Setting	Reset Setting	Page
 button	Operation Mode	 mode	—	—	—
Zoom button	Zoom Position	Full wide-angle	*	No	p.73
Four-way controller	 Drive Mode	 (Standard)	*	Yes	p.84 p.85
	 Shooting Mode	 (Auto Picture)	Yes	Yes	p.67
	 Flash Mode	 (Auto)	*	Yes	p.88
	 Focus Mode	<b>AF</b> (Standard)	*	Yes	p.89
<b>MENU</b> button	Menu Display	Capture mode: [  Rec. Mode] menu Playback mode: [  Setting] menu	—	—	p.55
<b>OK/DISPLAY</b> button	Information Display	Normal	*	Yes	p.20



# List of World Time Cities

**City:** indicates cities that can be set as either the Initial Setting (p.42) or the World Time (p.168).  
**Video Output Format:** indicates the video output format of the city set as the initial setting.

Region	City	Video Output Format	Region	City	Video Output Format
North America	Honolulu	NTSC	Africa/ West Asia	Istanbul	PAL
	Anchorage	NTSC		Cairo	PAL
	Vancouver	NTSC		Jerusalem	PAL
	San Francisco	NTSC		Nairobi	PAL
	Los Angeles	NTSC		Jeddah	PAL
	Calgary	NTSC		Tehran	PAL
	Denver	NTSC		Dubai	PAL
	Chicago	NTSC		Karachi	PAL
	Miami	NTSC		Kabul	PAL
	Toronto	NTSC		Male	PAL
	New York	NTSC		Delhi	PAL
Halifax	NTSC	Colombo		PAL	
Central and South America	Mexico City	NTSC		Kathmandu	PAL
	Lima	NTSC		Dacca	PAL
	Santiago	NTSC	East Asia	Yangon	NTSC
	Caracas	NTSC		Bangkok	PAL
	Buenos Aires	PAL		Kuala Lumpur	PAL
	Sao Paulo	PAL		Vientiane	PAL
Rio de Janeiro	NTSC	Singapore		PAL	
Europe	Lisbon	PAL		Phnom Penh	PAL
	Madrid	PAL		Ho Chi Minh	PAL
	London	PAL		Jakarta	PAL
	Paris	PAL		Hong Kong	PAL
	Amsterdam	PAL		Beijing	PAL
	Milan	PAL		Shanghai	PAL
	Rome	PAL		Manila	NTSC
	Copenhagen	PAL		Taipei	NTSC
	Berlin	PAL		Seoul	NTSC
	Prague	PAL	Tokyo	NTSC	
	Stockholm	PAL	Guam	NTSC	
	Budapest	PAL	Oceania	Perth	PAL
	Warsaw	PAL		Adelaide	PAL
	Athens	PAL		Sydney	PAL
	Helsinki	PAL		Noumea	PAL
Moscow	PAL	Wellington		PAL	
Africa/ West Asia	Dakar	PAL		Auckland	PAL
	Algiers	PAL		Pago Pago	NTSC
	Johannesburg	PAL			

# Optional Accessories

A number of dedicated accessories are available for this camera. Products marked with an asterisk (\*) are the same as those supplied with the camera.

- **Power supply**

- Rechargeable lithium-ion battery D-LI78 (\*)**

- Power adapter D-PA116 (\*)**

- Battery charger kit K-BC78**

- (Battery charger D-BC78, AC plug cord)**

- The battery charger is only sold as a kit.

- **Cable**

- USB cable I-USB116 (\*)**

- AV cable I-AVC116 (\*)**

- **Strap**

- O-ST116 (\*)**

- O-ST8** Silver chain strap

- O-ST24** Genuine leather strap

- O-ST81** Waterproof strap

- **Camera case**

- O-CC81**

- **Remote Control**

- REMOTE CONTROL WATERPROOF O-RC1**

- REMOTE CONTROL E**

- REMOTE CONTROL F**

# Main Specifications

Type	Fully automatic compact digital still camera with built-in zoom lens
Number of Effective Pixels	Approx. 14 megapixels
Image Sensor	1/2.3 inch CCD
Number of Recorded Pixels	Still $\overline{14M}$ (4288×3216), $\overline{10M}$ (1:1) (3216×3216), $\overline{10M}$ (16:9) (4224×2376), $\overline{7M}$ (3072×2304), $\overline{2M}$ (16:9) (1920×1080), $\overline{640}$ (640×480) * Fixed at $\overline{3M}$ in Frame Composite mode. * Fixed at $\overline{5M}$ in Digital SR/Miniature Filter/Burst Shooting mode, or when the sensitivity is set to 3200 or 6400.
	Movie $\overline{1280}$ (1280×720/30 fps), $\overline{1280}$ (1280×720/15 fps), $\overline{640}$ (640×480/30 fps), $\overline{640}$ (640×480/15 fps), $\overline{320}$ (320×240/30 fps), $\overline{320}$ (320×240/15 fps) (recorded pixels/frame rate)
Sensitivity (Standard Output Sensitivity)	Auto (ISO 64, 100, 200, 400, 800) Manual (ISO 64, 100, 200, 400, 800, 1600, 3200, 6400) * Fixed at Auto (ISO 64 - 6400) in Digital SR mode.
File Format	Still JPEG (Exif 2.3), DCF 2.0, DPOF, PRINT Image Matching III Movie AVI (Motion JPEG), approx. 30fps/15fps, PCM system, monaural sound, Movie SR (Movie Shake Reduction) Sound Voice memo, Voice recording: WAV (PCM) system, monaural
Storage Media	Built-in memory (approx. 42.7 MB), SD Memory Card, SDHC Memory Card, SDXC Memory Card

## Approximate Image Storage Capacity and Recording Time

### Still Pictures

		Built-in Memory	2 GB SD Memory Card
<b>14M</b>	4288×3216	17 pictures	778 pictures
<b>10M(H)</b>	3216×3216	23 pictures	1024 pictures
<b>10M(FS)</b>	4224×2376	23 pictures	1059 pictures
<b>7M</b>	3072×2304	33 pictures	1499 pictures
<b>2M(FS)</b>	1920×1080	91 pictures	4098 pictures
<b>640</b>	640×480	456 pictures	20491 pictures

- The image storage capacity is for reference only when images are recorded on blank built-in memory or SD Memory Card. If movies or sound are recorded, the image storage capacity is decreased. The actual image storage capacity may vary depending on the SD Memory Card and the subject.

### Movie/Sound

		Built-in Memory	2 GB SD Memory Card
<b>1280</b>	1280×720/30 fps	20 sec.	16 min. 45 sec.
<b>1280</b>	1280×720/15 fps	35 sec.	29 min. 46 sec.
<b>640</b>	640×480/30 fps	34 sec.	28 min. 23 sec.
<b>640</b>	640×480/15 fps	1 min. 5 sec.	54 min. 1 sec.
<b>320</b>	320×240/30 fps	50 sec.	41 min. 52 sec.
<b>320</b>	320×240/15 fps	1 min. 33 sec.	1 hr. 17 min. 00 sec.
	Sound	11 min. 38 sec.	8 hr. 44 min. 33 sec.

- The above figures are based on our standard shooting conditions and may vary depending on the subject, shooting conditions and type of the SD Memory Card used. If other data such as still images are recorded, recording time becomes shorter.
- Recording can continue until the built-in memory or the SD Memory Card is full, or the size of the recorded movie reaches 2 GB (when using a large capacity memory card). If recording stops at 2 GB, start recording again to continue to record the movie in blocks of 2 GB.

White Balance	Auto, Daylight, Shade, Tungsten Light, Fluorescent Light, Manual		
Lens	Focal Length	5 mm - 25 mm (approx. 28 mm - 140 mm in 35 mm equivalent focal length)	
	Aperture	F3.9 (W) - F5.7 (T)	
	Lens Composition	9 elements in 8 groups (4 aspherical elements)	
	Zoom Type	Electrically driven	
Optical Zoom	5×		

Intelligent Zoom	Approx. 7.0× at [7m] (3072×2304), Approx. 33.5× at [640] (640×480) (when combined with optical zoom)	
Digital Zoom	Up to approx. 6.7× (combines with 5× optical zoom to give zoom magnification equivalent to approx. 33.5×)	
Shake Reduction	Still	Optical shake reduction, High-sensitivity anti-shake mode (Digital SR)
	Movie	Electronic movie shake reduction (Movie SR)
Display	2.7 inch LCD, approx. 230,000 dots, Wide viewing angle	
Playback Modes	Single-frame, 4-frame, 9-frame, Enlargement (max. 10×, scrollable), Folder Display, Calendar Display, Sound Playback, Histogram Display, Deleting Selected Images, Slideshow, Image Rotation, Miniature Filter, HDR Filter, Digital Filter, Frame Composite, Movie Playback/Edit (Save as still images, Divide a movie), Red-eye Compensation, Resize, Cropping, Image/Sound Copy, Voice Memo, Protect, DPOF, Start-up Image Setting	
Focus Modes	Autofocus, Macro, Super Macro, Pan Focus, Infinity, Manual Focus	
Focus	Type	TTL contrast detection system by sensor 9-point autofocus (multiple/spot/automatic tracking AF changeable)
	Focus range (From lens face)	Standard : 0.4 m - ∞ (Wide-angle) 1 m - ∞ (Telephoto)
		Macro : 0.1 m - 0.5 m (Wide-angle) 0.3 m - 0.5 m (Mid-zoom)
		Super Macro : 0.05 m - 0.3 m (Telephoto)
* It is possible to switch to Pan Focus, Infinity and Manual Focus. * Face Detection AF is available only while the camera detects the subject's face.		
Focus Lock	By half-pressing the shutter release button	
Exposure Control	Metering System	Multi-segment metering, Center-weighted metering, Spot metering
	Exposure Compensation	±2 EV (can be set in 1/3 EV steps)
Face Detection	Detection of up to 16 people's faces (up to 16 face detection frames on the display), Smile Capture, Blink Detection * Face Detection AE is available only while the camera detects the subject's face.	
Shooting Modes	Auto Picture, Program, Blue Sky, Landscape, Flower, Sunset, Night Scene, Night Scene Portrait, Portrait, Natural Skin Tone, Food, Digital SR, Kids, Pet, Sport, Surf & Snow, Fireworks, Frame Composite, Party, Candlelight, Text, Miniature Filter, HDR Filter, Green	
Digital Filters	B&W, Sepia, Toy Camera, Retro (Blue, Amber), Color (Red, Pink, Purple, Blue, Green, Yellow), Extract Color (Red, Green, Blue), Color Emphasis (Sky Blue, Fresh Green, Delicate Pink, Autumn Leaves), Soft, Brightness	

Movie	Continuous Recording Time	Approx. 1 second - until built-in memory or SD Memory Card is full (however, maximum size is limited to 2 GB)
Shutter Speed	1/1600 sec. - 1/4 sec., max. 4 sec. (Night Scene mode)	
Built-in Flash	Modes	Auto, Flash Off, Flash On, Auto + Red-eye, Flash On + Red-eye
	Flash Range	Wide-angle: approx. 0.3 m - 3.6 m (approx. 1.0 ft - 12 ft) (Sensitivity: in Auto condition) Telephoto: approx. 1.0 m - 2.5 m (approx. 3.3 ft - 8.2 ft) (Sensitivity: in Auto condition)
Drive Modes	Single-frame, Self-timer (approx. 10 sec., approx. 2 sec.), Continuous Shooting, Burst Shooting, Remote Control	
Self-timer	Electronic control type, control time: Approx. 10 sec., 2 sec.	
Time Function	World Time	75 cities (28 time zones)
Power Source	Rechargeable lithium-ion battery D-LI78	
Battery Life	Number of Recordable Images approx. 180 pictures	* Recording capacity shows approximate number of shots recorded during CIPA-compliant testing (with display on, flash used for 50% of the shots, and 23 degrees centigrade). Actual performance may vary according to operating conditions.
	Playback Time approx. 120 min.	* According to the result of in-house testing. Actual time may differ depending on usage conditions.
	Movie Recording Time approx. 70 min.	
	Sound Recording Time approx. 110 min.	
Interfaces	USB 2.0 (high-speed compatible) /PC/AV terminal	
Video Output	NTSC/PAL (monaural)	
Dimensions	Approx. 90.5 (W) × 54.5 (H) × 20.5 (D) mm (excluding operating or protruding parts)	
Weight	Approx. 110 g (excluding battery and SD Memory Card) Approx. 126 g (including battery and SD Memory Card)	
Accessories	Rechargeable lithium-ion battery, Power adapter, USB cable, AV cable, Software (CD-ROM), Strap, Operating Manual, Quick Guide	

# WARRANTY POLICY

All PENTAX cameras purchased through authorized bona fide photographic distribution channels are guaranteed against defects of material or workmanship for a period of twelve months from date of purchase. Service will be rendered, and defective parts will be replaced without cost to you within that period, provided the equipment does not show evidence of impact, sand or liquid damage, mishandling, tampering, battery or chemical corrosion, operation contrary to operating instructions, or modification by an unauthorized repair shop. The manufacturer or its authorized representatives shall not be liable for any repair or alterations except those made with its written consent and shall not be liable for damages from delay or loss of use or from other indirect or consequential damages of any kind, whether caused by defective material or workmanship or otherwise; and it is expressly agreed that the liability of the manufacturer or its representatives under all guarantees or warranties, whether expressed or implied, is strictly limited to the replacement of parts as hereinbefore provided. No refunds will be made on repairs by non-authorized PENTAX service facilities.

## Procedure During 12-month Warranty Period

Any PENTAX which proves defective during the 12-month warranty period should be returned to the dealer from whom you purchased the equipment or to the manufacturer. If there is no representative of the manufacturer in your country, send the equipment to the manufacturer, with postage prepaid. In this case, it will take a considerable length of time before the equipment can be returned to you owing to the complicated customs procedures required. If the equipment is covered by warranty, repairs will be made and parts replaced free of charge, and the equipment will be returned to you upon completion of servicing. If the equipment is not covered by warranty, regular charges of the manufacturer or of its representatives will apply. Shipping charges are to be borne by the owner. If your PENTAX was purchased outside of the country where you wish to have it serviced during the warranty period, regular handling and servicing fees may be charged by the manufacturer's representatives in that country. Notwithstanding this, your PENTAX returned to the manufacturer will be serviced free of charge according to this procedure and warranty policy. In any case, however, shipping charges and customs clearance fees to be borne by the sender. To prove the date of your purchase when required, please keep the receipt or bills covering the purchase of your equipment for at least a year. Before sending your equipment for servicing, please make sure that you are sending it to the manufacturer's authorized representatives or their approved repair shops, unless you are sending it directly to the manufacturer. Always obtain a quotation for the service charge, and only after you accept the quoted service charge, instruct the service station to proceed with the servicing.

- This warranty policy does not affect the customer's statutory rights.
- The local warranty policies available from PENTAX distributors in some countries can supersede this warranty policy. Therefore, we recommend that you review the warranty card supplied with your product at the time of purchase, or contact the PENTAX distributor in your country for more information and to receive a copy of the warranty policy.



The CE Mark is a Directive conformity mark of the European Union.



## **For customers in USA**

### **STATEMENT OF FCC COMPLIANCE**

This device complies with Part 15 of the FCC Rules. Operation is subject to the following two conditions: (1) This device may not cause harmful interference, and (2) this device must accept any interference received, including interference that may cause undesired operation.

Changes or modifications not approved by the party responsible for compliance could void the user's authority to operate the equipment. This equipment has been tested and found to comply with the limits for a Class B digital device, pursuant to part 15 of the FCC Rules. These limits are designed to provide reasonable protection against harmful interference in a residential installation. This equipment generates, uses and can radiate radio frequency energy and, if not installed and used in accordance with the instructions, may cause harmful interference to radio communications. However, there is no guarantee that interference will not occur in a particular installation. If this equipment does cause harmful interference to radio or television reception, which can be determined by turning the equipment off and on, the user is encouraged to try to correct the interference by one or more of the following measures:

- Reorient or relocate the receiving antenna.  
Increase the separation between the equipment and receiver.  
Connect the equipment into an outlet on a circuit different from that to which the receiver is connected.
- \* Consult the dealer or an experienced radio/TV technician for help.

## **For customers in Canada**

This Class B digital apparatus complies with Canadian ICES-003.

### **Pour les utilisateurs au Canada**

Cet appareil numérique de la classe B est conforme à la norme NMB-003 du Canada.

### **FOR CALIFORNIA, U.S.A. ONLY**

Perchlorate Material-special handling may apply. The lithium battery used in this camera contains perchlorate material, which may require special handling. See [www.dtsc.ca.gov/hazardouswaste/perchlorate](http://www.dtsc.ca.gov/hazardouswaste/perchlorate)

# Declaration of Conformity

According to 47CFR, Parts 2 and 15 for  
Class B Personal Computers and Peripherals

We: PENTAX Imaging Company  
A Division of PENTAX of America, Inc.

Located at: 600 12<sup>th</sup> Street, Suite 300  
Golden, Colorado 80401 U.S.A.  
Phone: 303-799-8000 FAX: 303-790-1131

Declare under sole responsibility that the product identified herein complies with 47CFR Parts 2 and 15 of the FCC rules as a Class B digital device. Each product marketed is identical to the representative unit tested and found to be compliant with the standards. Records maintained continue to reflect the equipment being produced can be expected to be within the variation accepted, due to quantity production and testing on the statistical basis as required by 47CFR §2.909. Operation is subject to the following two conditions: (1) This device may not cause harmful interference, and (2) This device must accept any interference received, including interference that may cause undesired operation. The above named party is responsible for ensuring that the equipment complies with the standards of 47CFR §15.101 to §15.109.

Product Name: PENTAX Digital Still Camera

Model Number: Optio S1

Contact person: Customer Service Manager

Date and Place: March, 2011, Colorado

## Information for Users on Collection and Disposal of Old Equipment and Used Batteries



### 1. In the European Union

These symbols on the products, packaging and/or accompanying documents mean that used electrical and electronic equipments and batteries should not be mixed with general household waste.

Used electrical/electronic equipments and batteries must be treated separately and in accordance with legislation that requires proper treatment, recovery and recycling of these products.

Following the implementation by member states, private households within the EU states may return their used electrical/electronic equipments and batteries to designated collection facilities free of charge\*.

In some countries your local retailer may also take back your old product free of charge if you purchase a similar new one.

\*Please contact your local authority for further details.



By disposing of this product correctly you will help ensure that the waste undergoes the necessary treatment, recovery and recycling and thus prevent potential negative effects on the environment and human health which could otherwise arise due to inappropriate waste handling.

### 2. In other countries outside the EU

These symbols are only valid in the European Union. If you wish to discard these items, please contact your local authorities or dealer and ask for the correct method of disposal.



































Cd







For Switzerland: Used electrical/electronic equipment can be returned free of charge to the dealer, even when you don't purchase a new product. Further collection facilities are listed on the home page of [www.swico.ch](http://www.swico.ch) or [www.sens.ch](http://www.sens.ch).

Note for the battery symbol (bottom two symbol examples): This symbol might be used in combination with a designation for the chemical element or compound in use. In this case you have to comply with the requirement set by the Directive for the chemicals involved.





## Symbols

 Mode .....	12, 54
 Mode .....	12, 54
 button .....	50, 52
 button .....	51
[  Rec. Mode]	
menu .....	58, 202
[  Movie] Menu .....	59, 203
[  Setting] menu .....	60, 204
 Delete .....	116, 126
 Tele .....	73
 Wide .....	73
 Magnify .....	125
 Four-/Nine-image	
display .....	118
 Self-timer .....	84
 Continuous Shooting ....	85
 Burst Shooting .....	85
 Remote Control .....	86
 0-sec Remote Control ...	86
 Green Mode .....	72
 Auto Picture .....	70
 Program .....	71
 Blue Sky .....	68
 Landscape .....	68
 Flower .....	68
 Sunset .....	68
 Night Scene .....	75
 Night Scene Portrait ....	75
 Portrait .....	76
 Natural Skin Tone .....	76
 Food .....	68
 Digital SR .....	75
 Kids .....	77
 Pet .....	78
 Sport .....	79

 Surf & Snow .....	79
 Fireworks .....	75
 Frame Composite	
.....	80, 145
 Party .....	81
 Candlelight .....	75
 Text .....	82
 Miniature .....	83, 138
<b>HDR</b> HDR .....	83, 138

## A









Adding sound	
(Voice Memo) .....	161
AE Metering .....	98
Auto + Red-eye  .....	88
Auto <b>AWB</b> .....	96
Auto Picture Mode .....	70
Auto Power Off .....	176
Auto  .....	88
Automatic Tracking	
AF .....	69, 91
AV cable .....	132
AV equipment .....	132

## B





B&W filter .....	140
Basic mode .....	72
Battery level indicator .....	35
Blink Detection .....	67
Blue Sky Mode .....	68
Brightness filter .....	140
Brightness Level .....	174
Built-in memory .....	150
Burst Shooting  .....	85

## C



Calendar display .....	119
Camera shake .....	102, 112

Candlelight Mode .....	75	Error messages .....	198
Capture Mode Palette .....	67	Exposure setting .....	94
Center-weighted metering  .....	98	Extract Color filter .....	140
Charging a battery .....	33	<b>F</b>	
Checking the SD Memory		Face Detection .....	69, 100
Card .....	40	File number .....	113
City name .....	207	Filters .....	83, 138, 140
Color Emphasis filter .....	140	Fireworks Mode .....	75
Color filter .....	140	Flash Mode .....	88
Connecting to a TV .....	132	Flash Off  .....	88
Continuous Shooting  .....	85	Flash On + Red-eye  .....	88
Contrast .....	105	Flash On  .....	88
Copy .....	150	Flower Mode .....	68
Cropping .....	137	Fluores. Light  .....	96
<b>D</b>		Focus Mode .....	89
Date and time setting .....	46, 166	Focusing .....	89
Date Imprint .....	106	Focusing Area .....	91
Daylight  .....	96	Folder display .....	119
Daylight saving time .....	45, 169	Folder name .....	172
Default settings .....	202	Food Mode .....	68
Delete  .....	116, 126	Format .....	164
Delete all .....	128	Four-image display  .....	118
Delete sounds (voice memo) .....	126	Four-way controller .....	51, 53
Destination .....	168	Frame Composite .....	80, 145
Digital Filter .....	140	Frame rate .....	111
Digital SR .....	75	<b>G</b>	
Digital Zoom .....	73, 74	Green Button .....	51, 53, 107
Display brightness .....	174	Green Mode .....	72
Display language .....	42, 171	Guide indications .....	26
Dividing movies .....	149	<b>H</b>	
DPOF settings .....	153	HDR Filter .....	83, 138
D-Range Setting .....	95	Highlight Correction .....	95
Drive Mode .....	84, 85	Histogram .....	26
<b>E</b>		Hometown .....	45, 168
Editing movies .....	148	<b>I</b>	
		Image Storage Capacity .....	210

Infinity ▲	89	NTSC	173
Info Display	22	Number of pixels	92
Initial settings	42	<b>O</b>	
Installing a battery	31	<b>OK/DISPLAY</b> button	51, 53
Installing the Software	187	Opening screen	177
Instant Review	67, 103	Operating the menus	55
Intelligent Zoom	73	Optional accessory	208
<b>K</b>		<b>P</b>	
Kids Mode	77	PAL	173
<b>L</b>		Pan Focus <b>PF</b>	89
Landscape Mode	68	Party Mode	81
Language setting	42, 171	Pet Mode	78
<b>M</b>		Photo processing lab	153
Macintosh	187	Picture Transfer Protocol	183
Macro 🍷	89	.....	183
Magnify 🔍	125	Pixel Mapping	178
Manual Focus <b>MF</b>	89	Playback	116, 117, 159, 162
Manual 📄	96	Playback Mode	
Mass Storage Class	183	Palette	120, 205
MediaImpression	186	Playing back movies	117
Memory	113	Playing back sounds	159
<b>MENU</b> button	51, 53	Portrait Mode	76
Miniature Filter	83, 138	Power Saving	175
Movie	109	Power switch	40, 41, 50, 52
Movie Editing	148	Press fully	
Movie menu	59, 203	(shutter release button)	66
Movie SR (Movie Shake		Press halfway	
Reduction) Function	112	(shutter release button)	66
MSC	183	Product registration	190
Multi-segment		Program Mode	71
metering 📷	98	Protect 🔒	129
<b>N</b>		PTP	183
Natural Skin Tone Mode	76	<b>R</b>	
Night Scene Mode	75	Rec. Mode menu	58, 202
Night Scene Portrait		Recorded Pixels	92, 111
Mode	75	Recording movies	109
Nine-image display 📷	118	Recording sounds	158

Red-eye Compensation ...	144
Red-eye reduction   .....	88
Registering menu items ...	107
Remote Control   .....	86
Reset .....	179
Resize .....	136
Retro filter .....	140
Rotating .....	124

## S

Saturation .....	105
Saving as still picture (movie) .....	149
Saving pictures by date ...	172
Saving settings .....	113
Screen effect .....	122
SD Memory Card .....	36
Select Time .....	170
Self-timer  .....	84
Sensitivity .....	99
Sepia filter .....	140
Setting menu .....	60, 204
Shade  .....	96
Shadow Correction .....	95
Shake Reduction ....	102, 112
Sharpness .....	104
Shooting information .....	21
Shooting mode .....	67
Shutter release button .....	50, 52, 66
Slideshow .....	121
Smile Capture .....	69, 100
Soft filter .....	140
Sound settings .....	165
Sound types .....	165
Specifications .....	209
Sport Mode .....	79
Spot AE metering  .....	98
Standard <b>AF</b> .....	89

Starting-up in the playback mode .....	41
Start-up screen .....	177
Strap .....	30
Sunset Mode .....	68
Super Macro  .....	89
Surf & Snow Mode .....	79
System requirements .....	186

## T

Text Mode .....	82
Time imprint .....	106
Toy Camera filter .....	140
Tungsten Light  .....	96
TV .....	132

## U

USB Connection .....	182
----------------------	-----





## V

Video output format .....	173, 207
Voice Memo .....	161
Voice Recording .....	158
Volume change .....	117, 160, 165

## W

White Balance .....	96
Windows .....	186
World Time .....	168

## Z

Zoom /  /  /  /  .....	73
Zoom button .....	50, 52



# Memo

# Memo

# Memo

**HOYA CORPORATION**

**PENTAX Imaging Systems Division**

2-35-7, Maeno-cho, Itabashi-ku, Tokyo 174-8639, JAPAN  
(<http://www.pentax.jp>)

**PENTAX Europe Imaging  
Systems S.A.S.  
(European Headquarters)**

112 Quai de Bezons, B.P. 204, 95106 Argenteuil  
Cedex, FRANCE  
(HQ - <http://www.pentax.eu>)  
(France - <http://www.pentax.fr>)

**PENTAX Imaging Systems  
GmbH**

Julius-Vosseler-Strasse 104, 22527 Hamburg,  
GERMANY  
(<http://www.pentax.de>)

**PENTAX Imaging Systems  
Limited**

PENTAX House, Heron Drive, Langley, Slough, Berks  
SL3 8PN, U.K.  
(<http://www.pentax.co.uk>)

**PENTAX Imaging Company**

**A Division of PENTAX of America, Inc.**

(Headquarters)  
600 12th Street, Suite 300 Golden, Colorado 80401, U.S.A.  
(PENTAX Service Department)  
250 North 54th Street Chandler, Arizona 85226, U.S.A.  
(<http://www.pentaximaging.com>)

**PENTAX Canada Inc.**

1770 Argentia Road Mississauga, Ontario L5N 3S7,  
CANADA (<http://www.pentax.ca>)

**PENTAX Trading  
(SHANGHAI) Limited**

23D, Jun Yao International Plaza, 789 Zhaojiabang  
Road, Xu Hui District, Shanghai, 200032 CHINA  
(<http://www.pentax.com.cn>)

<http://www.pentax.jp/english>

- Specifications and external dimensions are subject to change without notice.